



US00D567409S

(12) **United States Design Patent**
Opfer et al.

(10) **Patent No.:** **US D567,409 S**

(45) **Date of Patent:** **** Apr. 22, 2008**

(54) **VEHICLE HEADLAMP**

(75) Inventors: **John G Opfer**, Rochester, MI (US);
Timothy W Anness, Rochester Hills,
MI (US)

(73) Assignee: **Chrysler LLC**, Auburn Hills, MI (US)

(**) Term: **14 Years**

(21) Appl. No.: **29/296,197**

(22) Filed: **Oct. 16, 2007**

Related U.S. Application Data

(63) Continuation-in-part of application No. 29/249,266,
filed on Sep. 29, 2006, now Pat. No. Des. 553,049.

(51) **LOC (8) Cl.** **26-06**

(52) **U.S. Cl.** **D26/28**

(58) **Field of Classification Search** D26/28-36;
362/459-468, 475-478, 485-487
See application file for complete search history.

(56) **References Cited**

U.S. PATENT DOCUMENTS

D538,956 S * 3/2007 Ishii D26/28
D552,770 S * 10/2007 Davidson D26/28

* cited by examiner

Primary Examiner—Marcus A. Jackson

(74) *Attorney, Agent, or Firm*—Ralph E. Smith

(57) **CLAIM**

The ornamental design for a vehicle headlamp, as shown and described.

DESCRIPTION

FIG. 1 is a front perspective view of a vehicle right headlamp (as viewed from the front of a vehicle) showing our new design;

FIG. 2 is a rear perspective view thereof;

FIG. 3 is a front view thereof;

FIG. 4 is a rear view thereof;

FIG. 5 is a side view thereof;

FIG. 6 is the opposite side view thereof;

FIG. 7 is a top plan view thereof; and,

FIG. 8 is a bottom plan view thereof.

It will be understood that the broken lines presented in the drawings are for illustration only, and do not form a part of the claimed design.

1 Claim, 8 Drawing Sheets

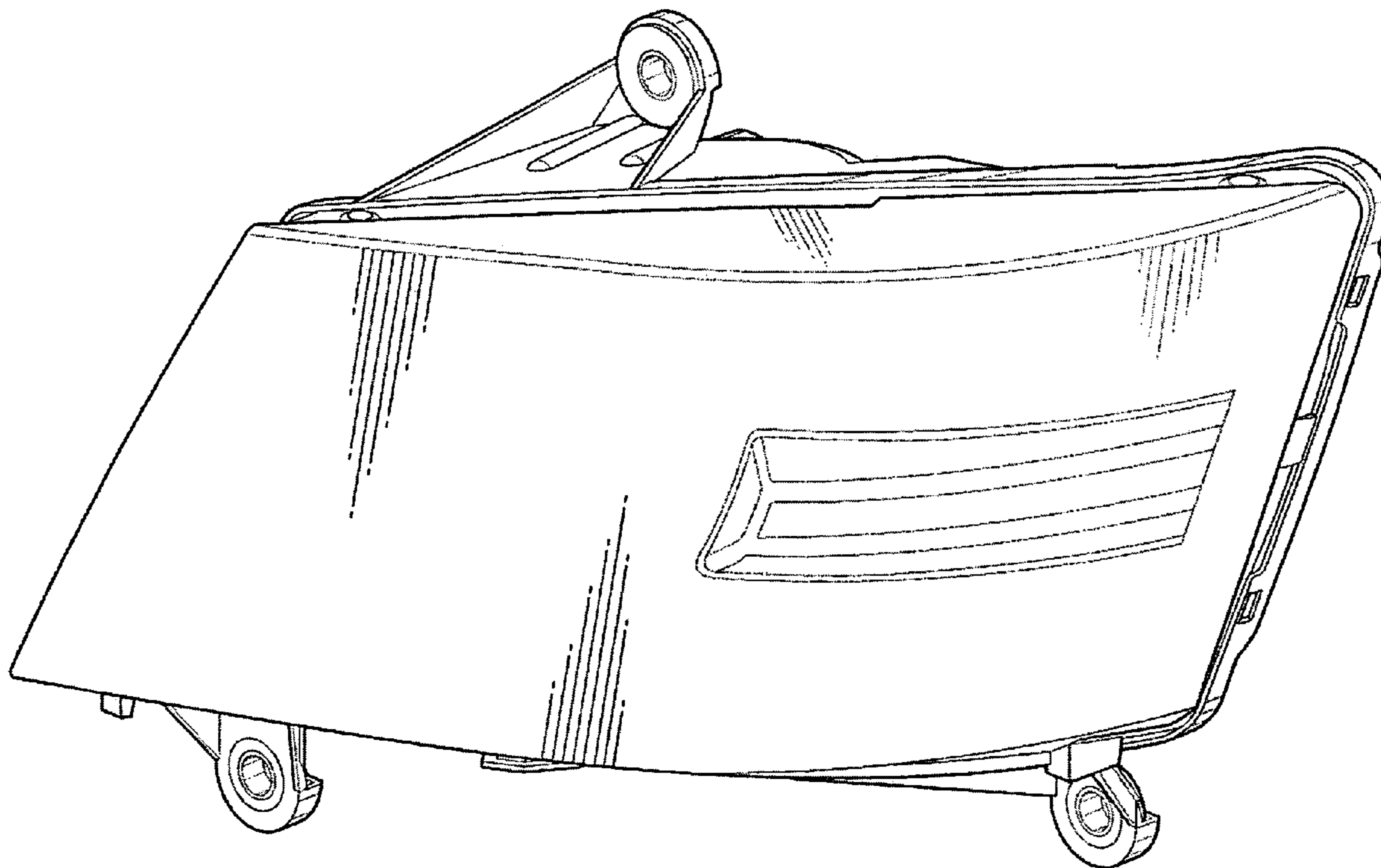

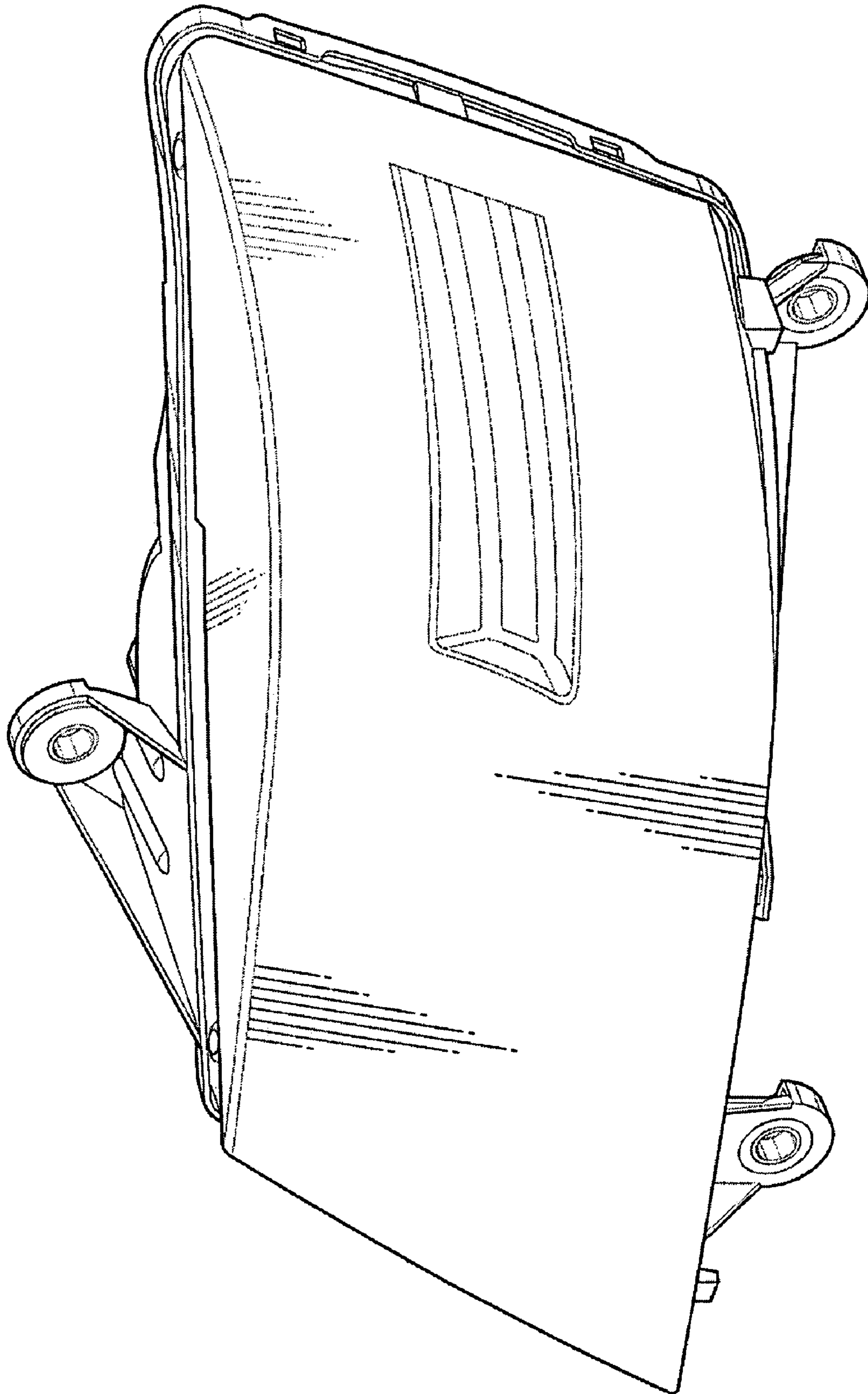

FIG - 1

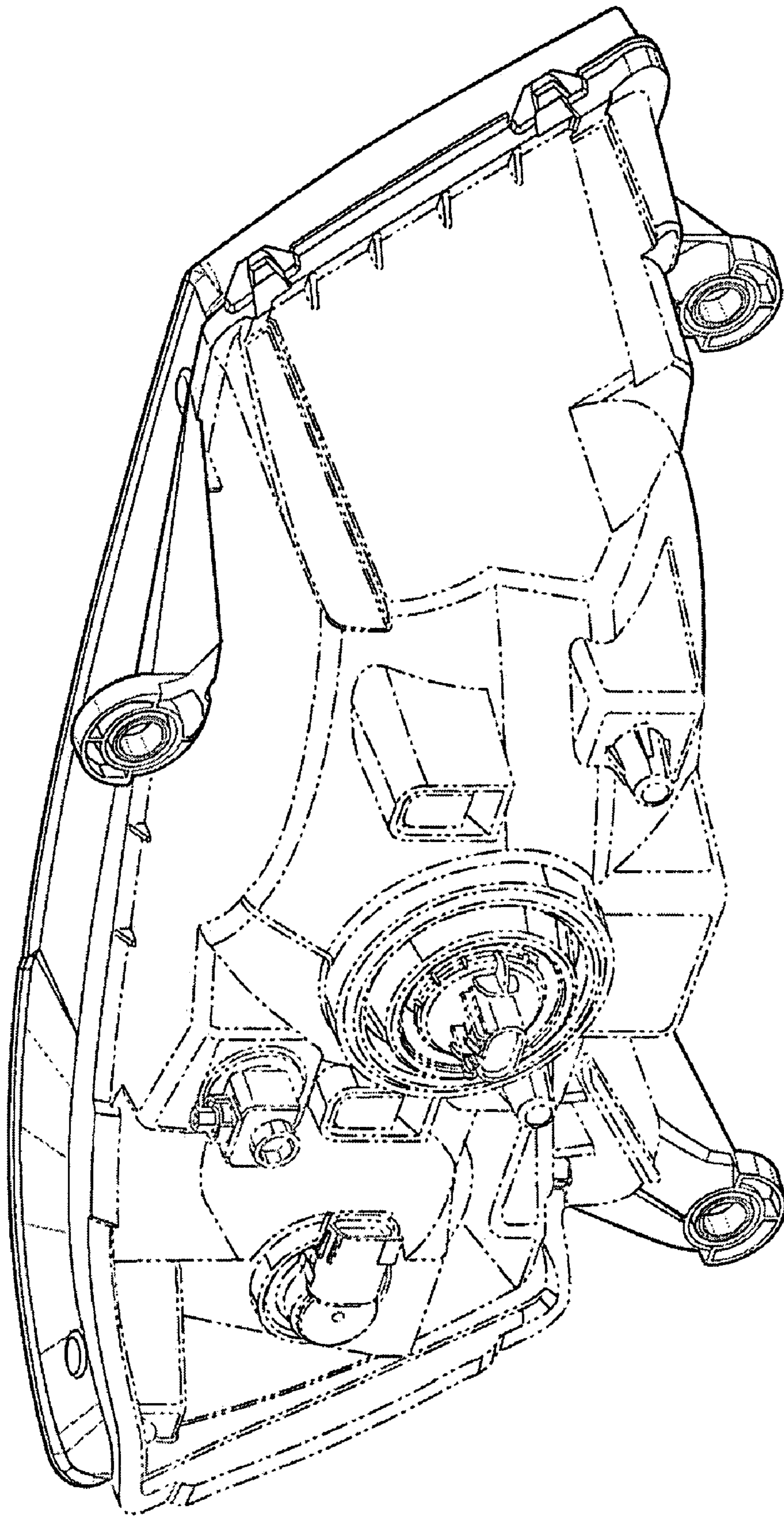

FIG - 2

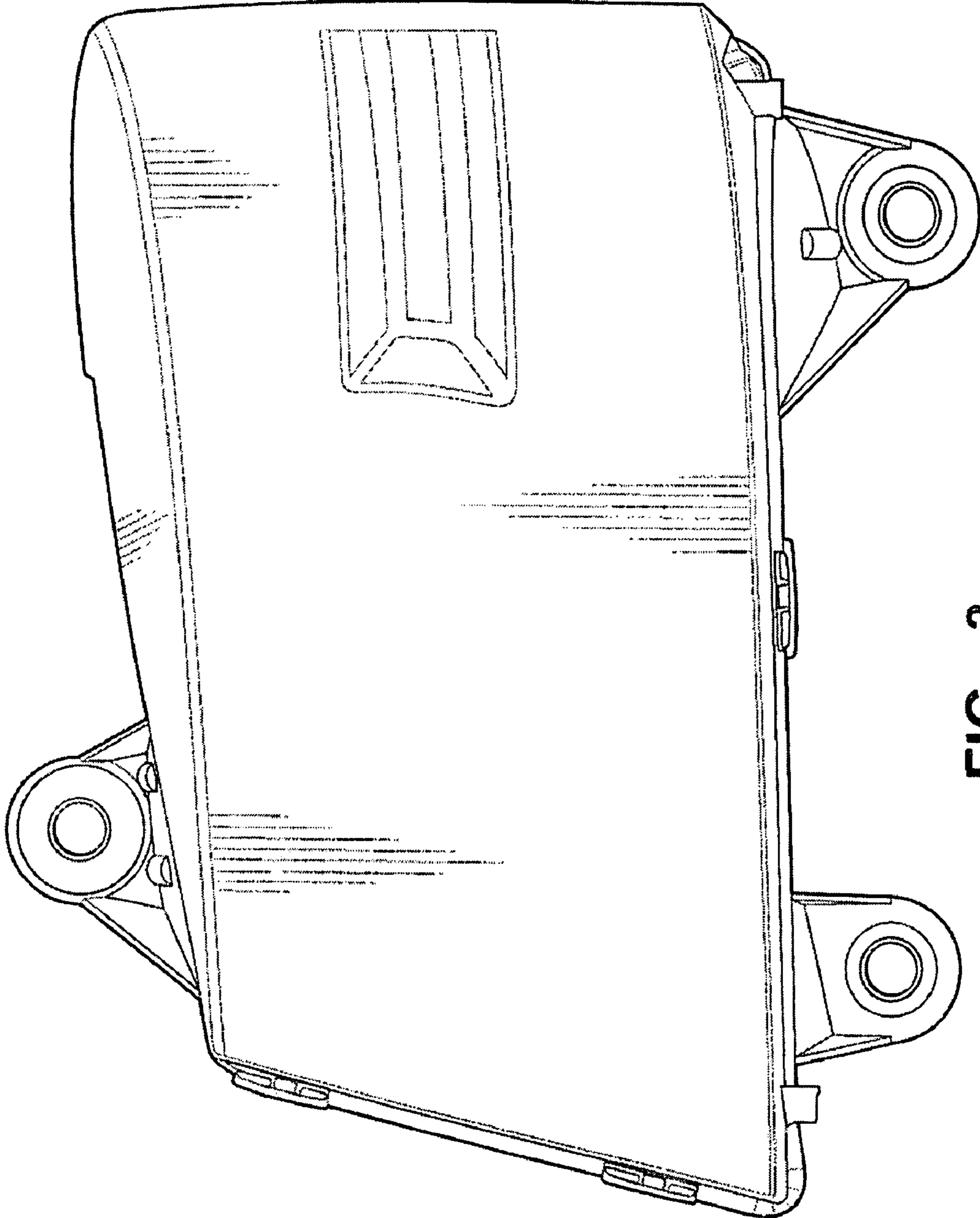

FIG - 3

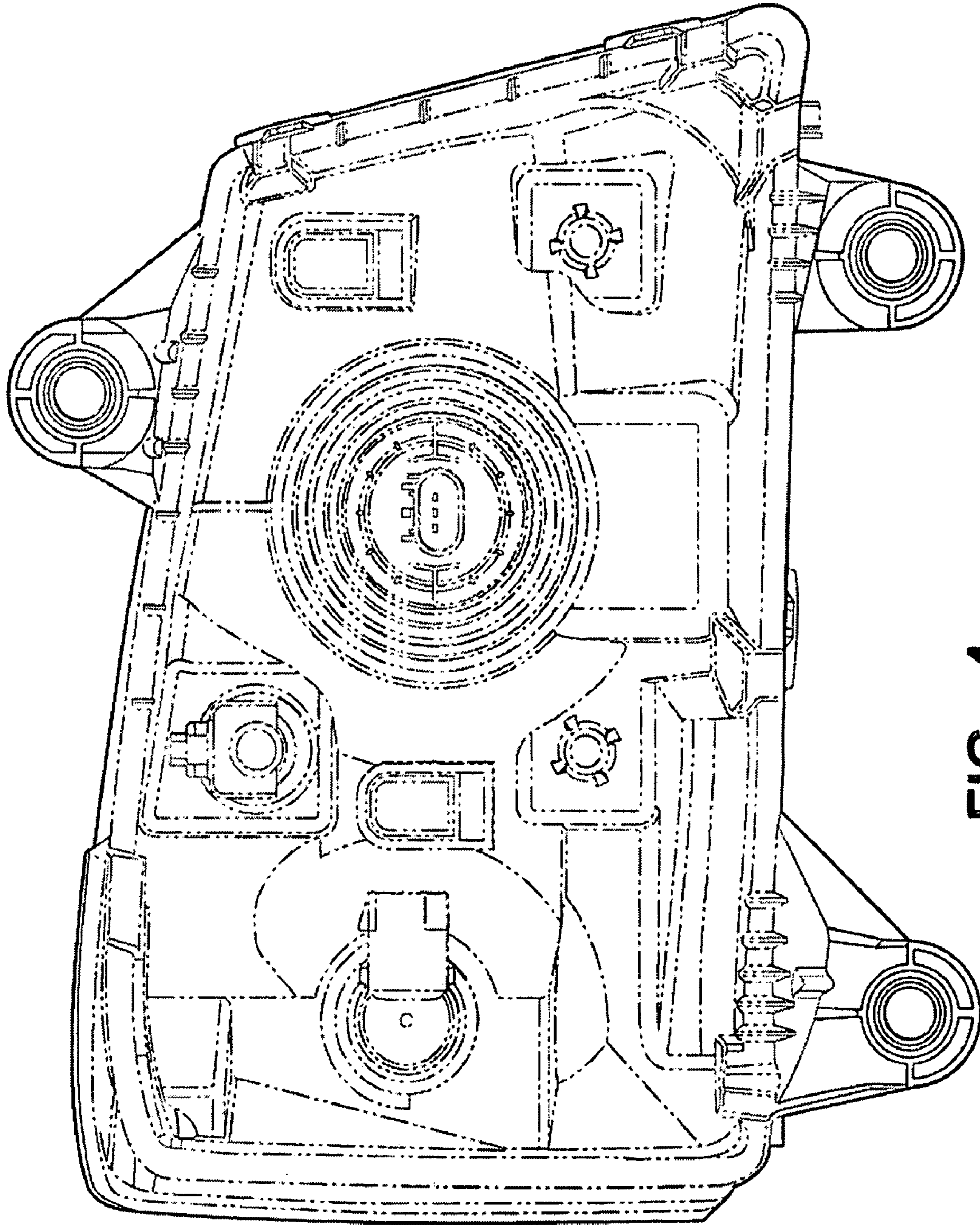

FIG - 4

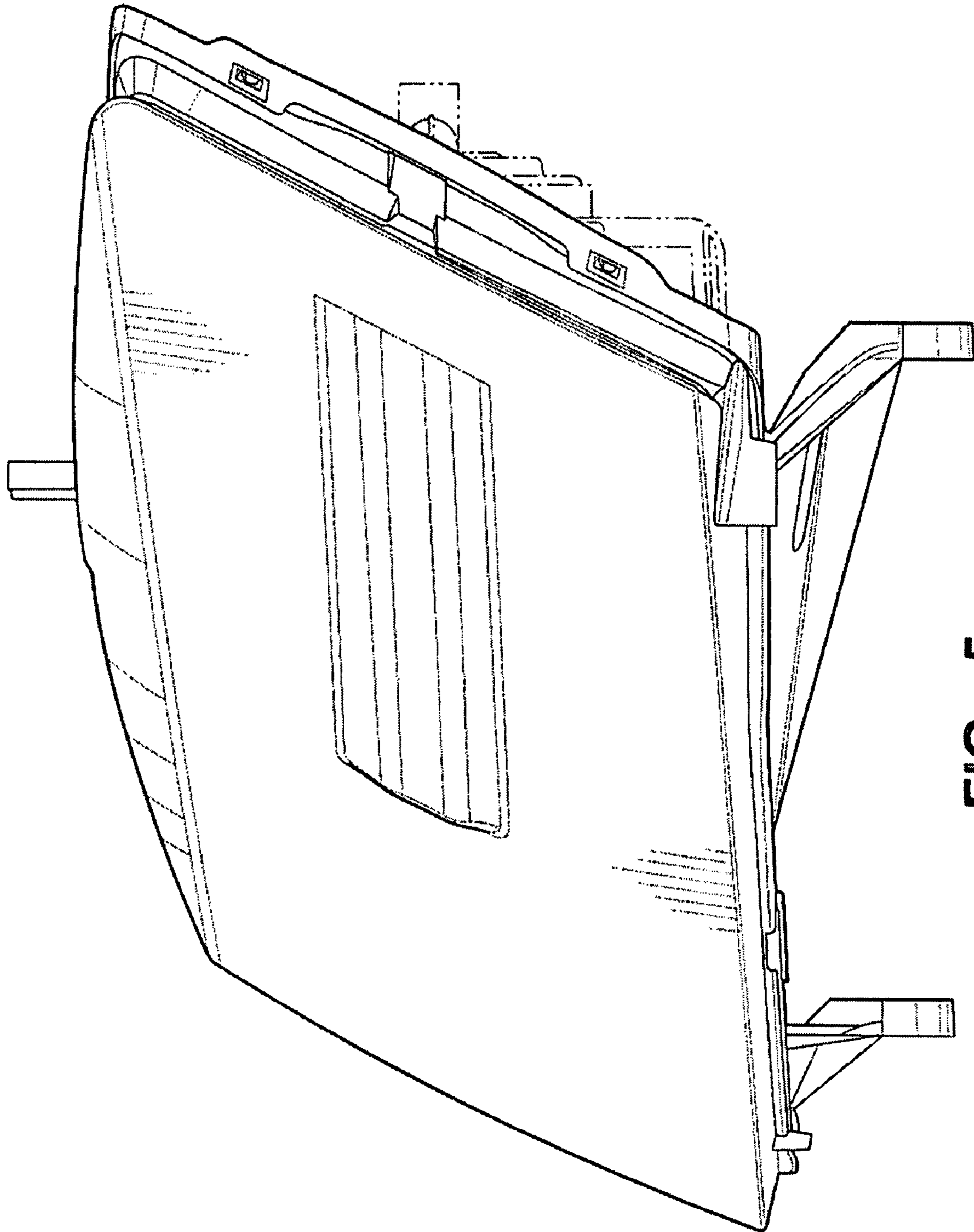

FIG - 5

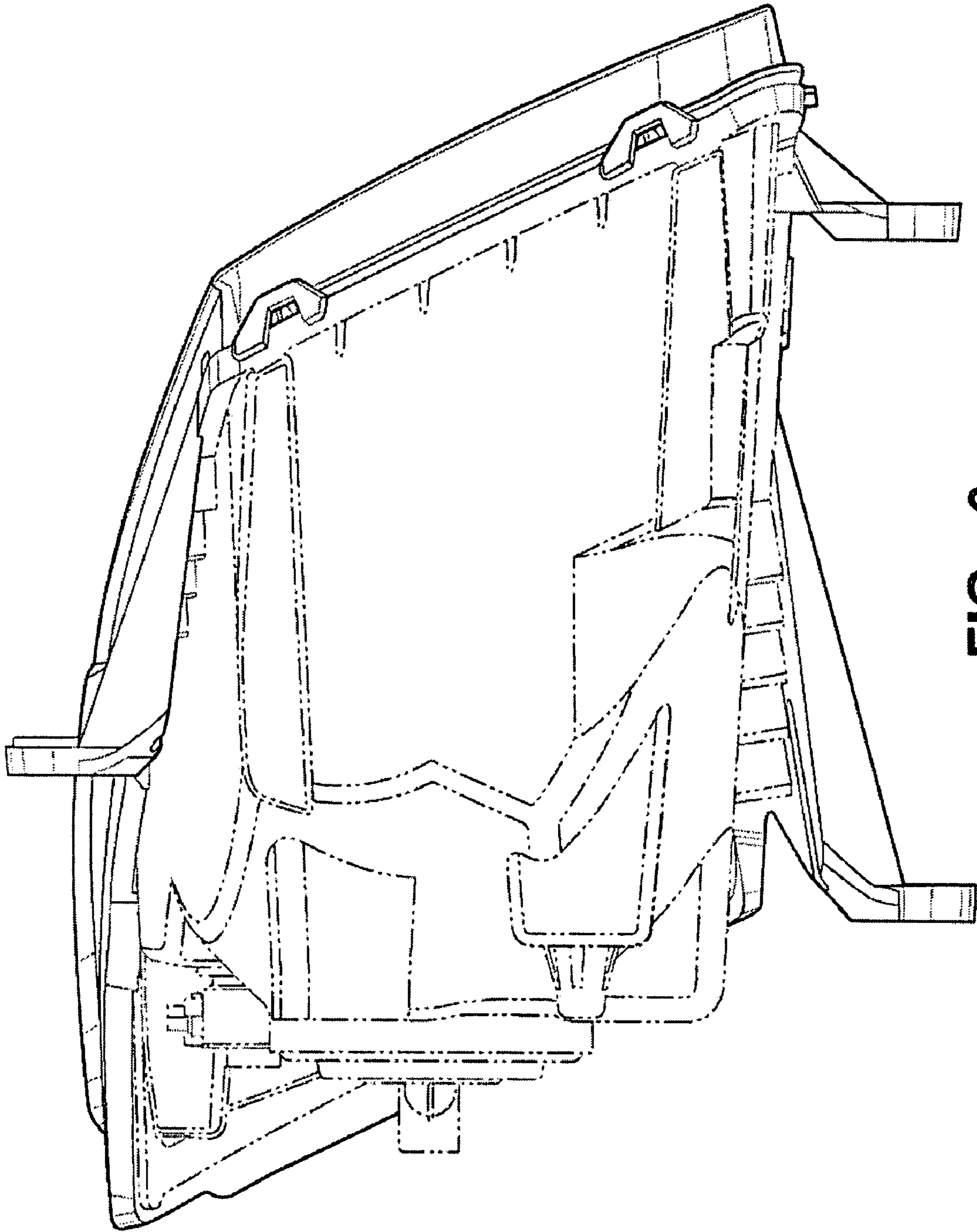

FIG - 6

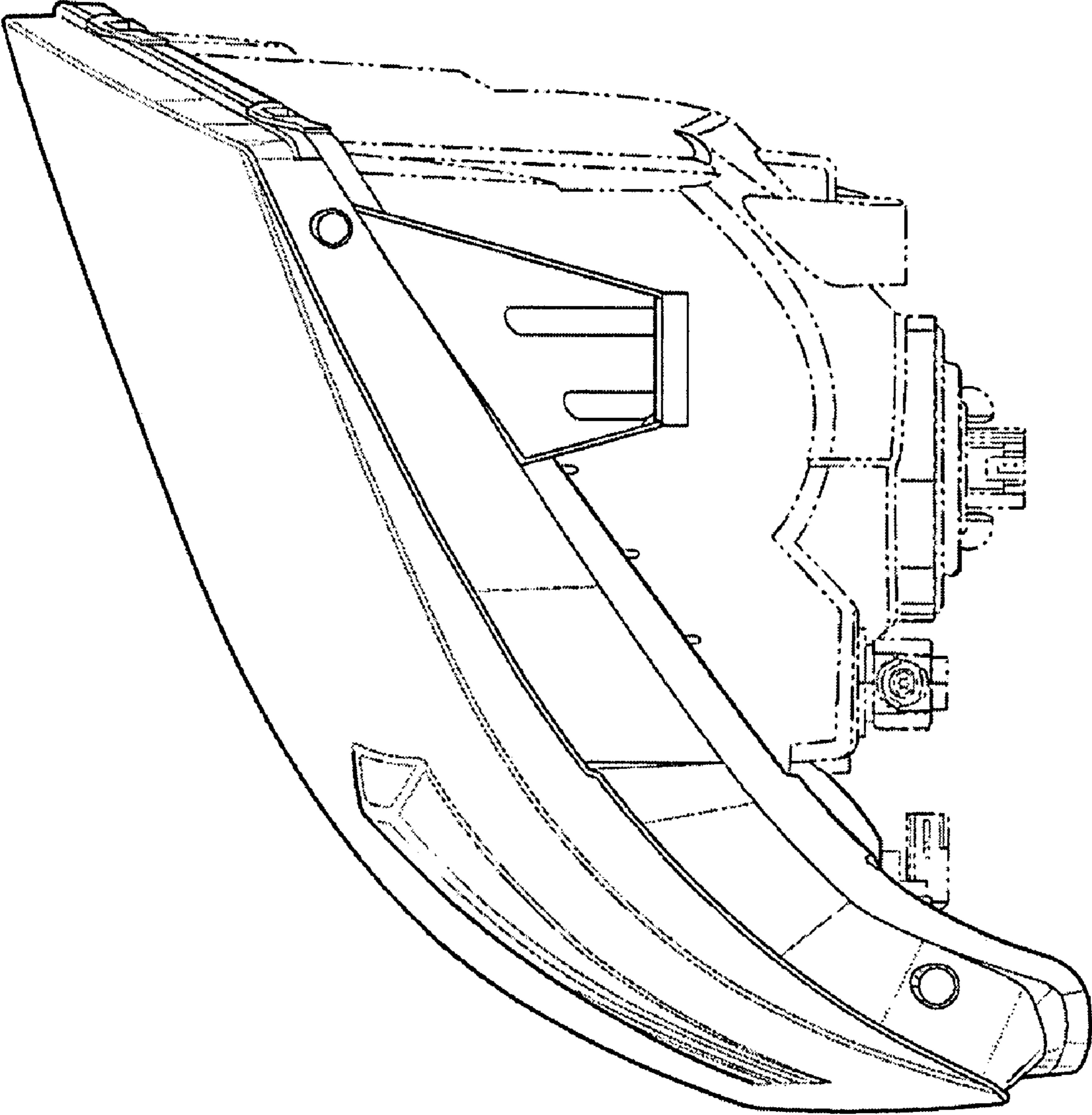

FIG - 7

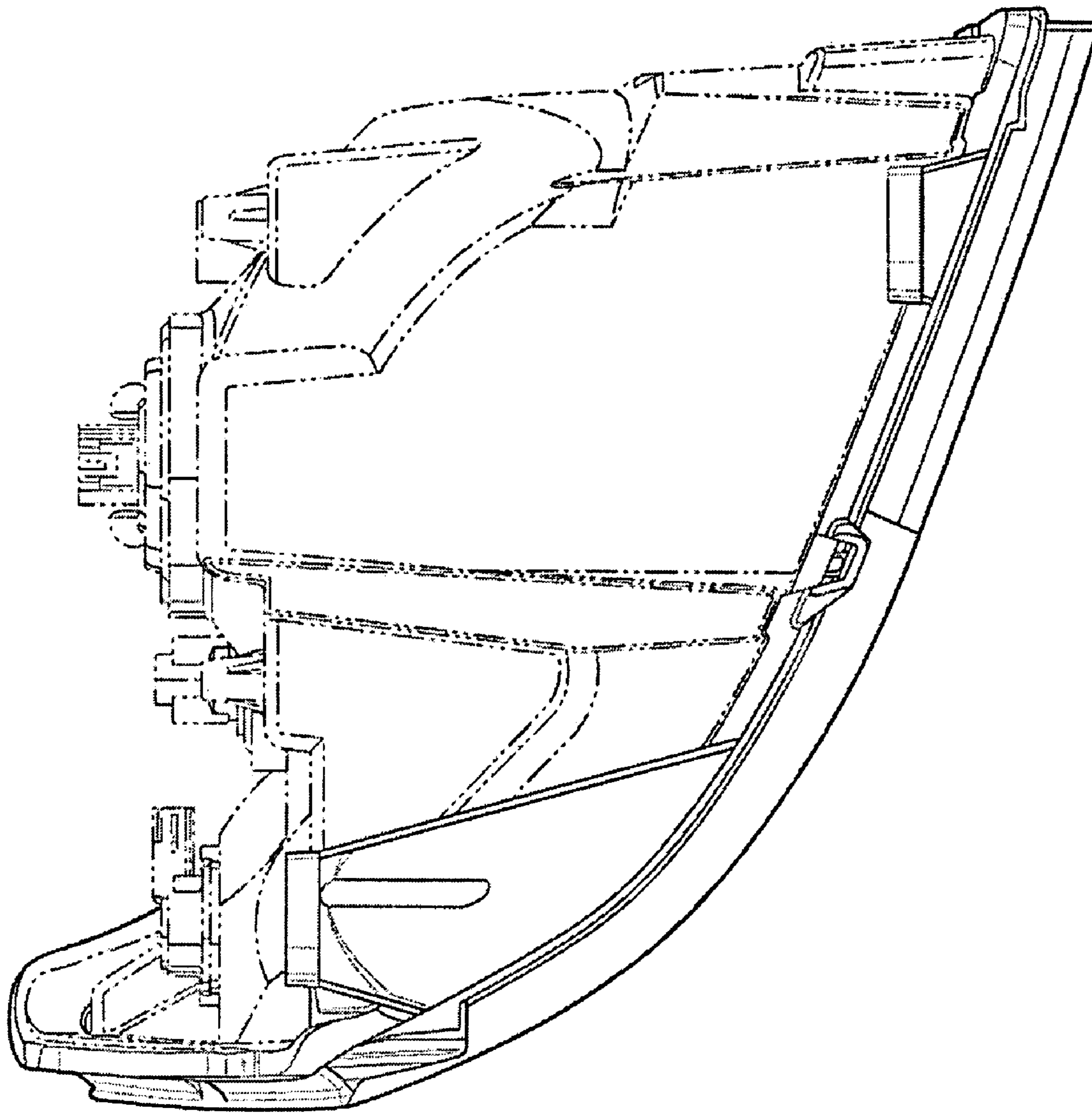

FIG - 8