



US00D567345S

(12) **United States Design Patent**  
**Dean et al.**

(10) **Patent No.:** **US D567,345 S**  
(45) **Date of Patent:** **\*\* Apr. 22, 2008**

(54) **COMBINED PORTABLE HEATER AND TOOLBOX**

(75) Inventors: **Bob Dean**, Laurinburg, NC (US);  
**Dennis Neibrook**, Florence, SC (US);  
**Bob Windmeyer**, Laurinburg, NC (US);  
**Lee Joyner**, Florence, SC (US); **Jeffrey A. White**, Pinehurst, NC (US); **Jim Garrigus**, Laurinburg, NC (US); **Frank L. Lockhart**, Florence, SC (US); **Colin O'Connell**, Pinehurst, NC (US); **Robert F. Deaver, II**, Tatum, SC (US)

(73) Assignee: **Marley Engineered Products LLC**,  
Bennettsville, SC (US)

(\*\*) Term: **14 Years**

(21) Appl. No.: **29/271,688**

(22) Filed: **Jan. 25, 2007**

(51) **LOC (8) Cl.** ..... **23-03**

(52) **U.S. Cl.** ..... **D23/317; D23/314; D23/328**

(58) **Field of Classification Search** ..... D23/317,  
D23/335, 332, 370, 381, 382, 329, 314, 328,  
D23/330, 336, 339, 340, 342, 348, 352, 355,  
D23/356, 362, 363, 364, 366, 375, 376, 385,  
D23/390, 403, 414, 499, 353, 333, 334, 344,  
D23/341; 392/358.365, 373-376, 366-369;  
219/533; 312/236

See application file for complete search history.

(56) **References Cited**

**U.S. PATENT DOCUMENTS**

D104,085 S \* 4/1937 Austin ..... D23/328  
D135,833 S \* 6/1943 Holthouse ..... D23/317

D186,793 S \* 12/1959 Shimano ..... D23/333  
D200,374 S \* 2/1965 Partanen ..... D23/315  
D203,785 S \* 2/1966 Meisner ..... D23/337  
D249,544 S \* 9/1978 Bonney ..... D23/343  
D254,864 S \* 4/1980 Skabelund et al. .... D23/350  
D313,069 S \* 12/1990 McCormick ..... D23/335  
D337,592 S \* 7/1993 Hider et al. .... D15/79  
D346,855 S \* 5/1994 Chiu ..... 23/328  
D358,636 S \* 5/1995 Bucher et al. .... D23/335  
7,190,887 B1 \* 3/2007 Compton ..... 392/365

\* cited by examiner

*Primary Examiner*—Robert M. Spear

*Assistant Examiner*—Anna K Dworzecka

(74) *Attorney, Agent, or Firm*—Baker & Hostetler LLP

(57) **CLAIM**

The ornamental design for a combined portable heater and toolbox, as shown and described.

**DESCRIPTION**

FIG. 1 is a perspective view of a combined portable heater and toolbox, particularly showing the inventive design thereof;

FIG. 2 is a front view thereof;

FIG. 3 is a rear view thereof;

FIG. 4 is a left side view thereof;

FIG. 5 is a right side view thereof;

FIG. 6 is a top view thereof; and,

FIG. 7 is a bottom view thereof.

The broken lines in the FIGS. are for illustrative purposes only and form no part of the claimed design.

**1 Claim, 4 Drawing Sheets**

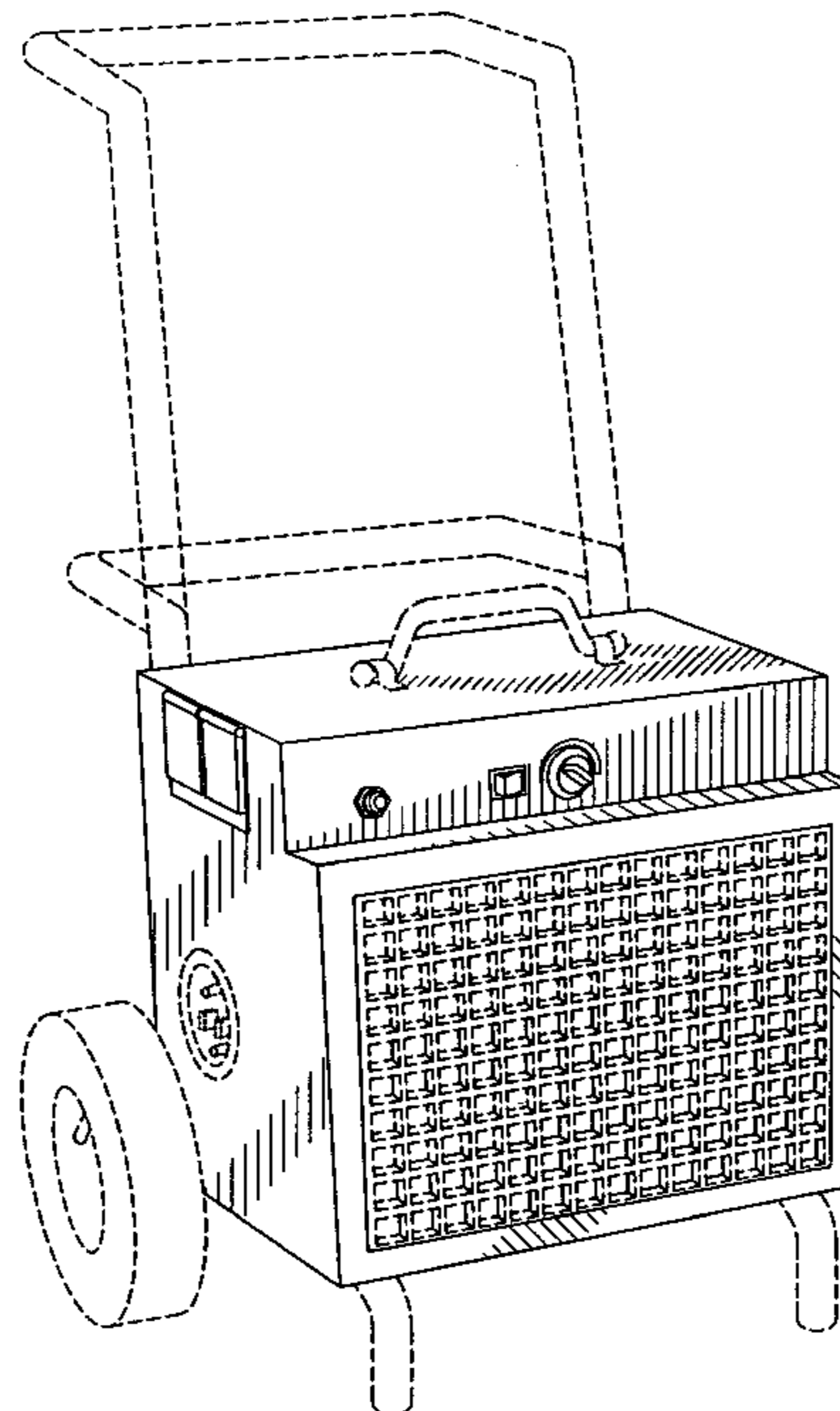

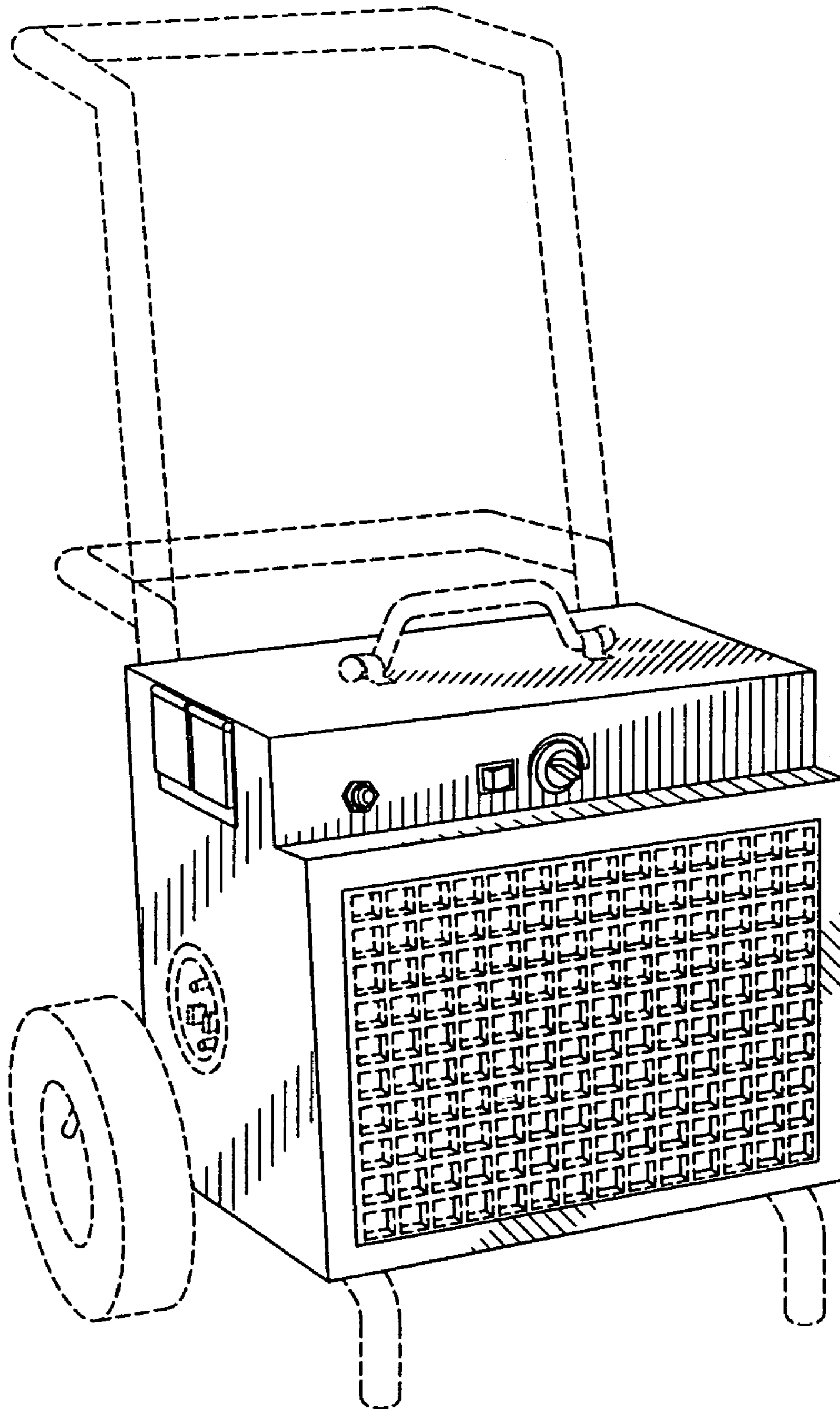

FIG. 1

FIG. 2

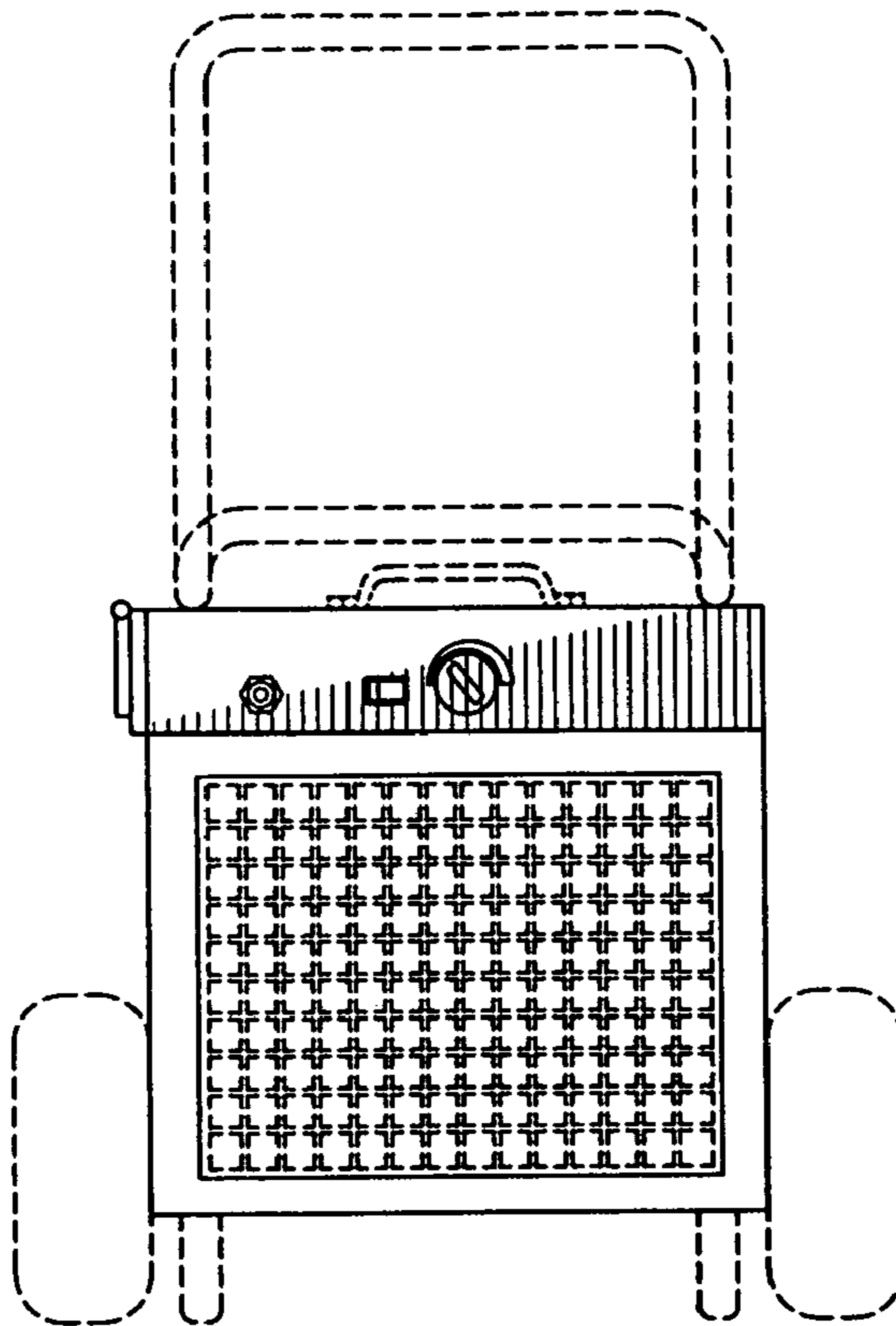
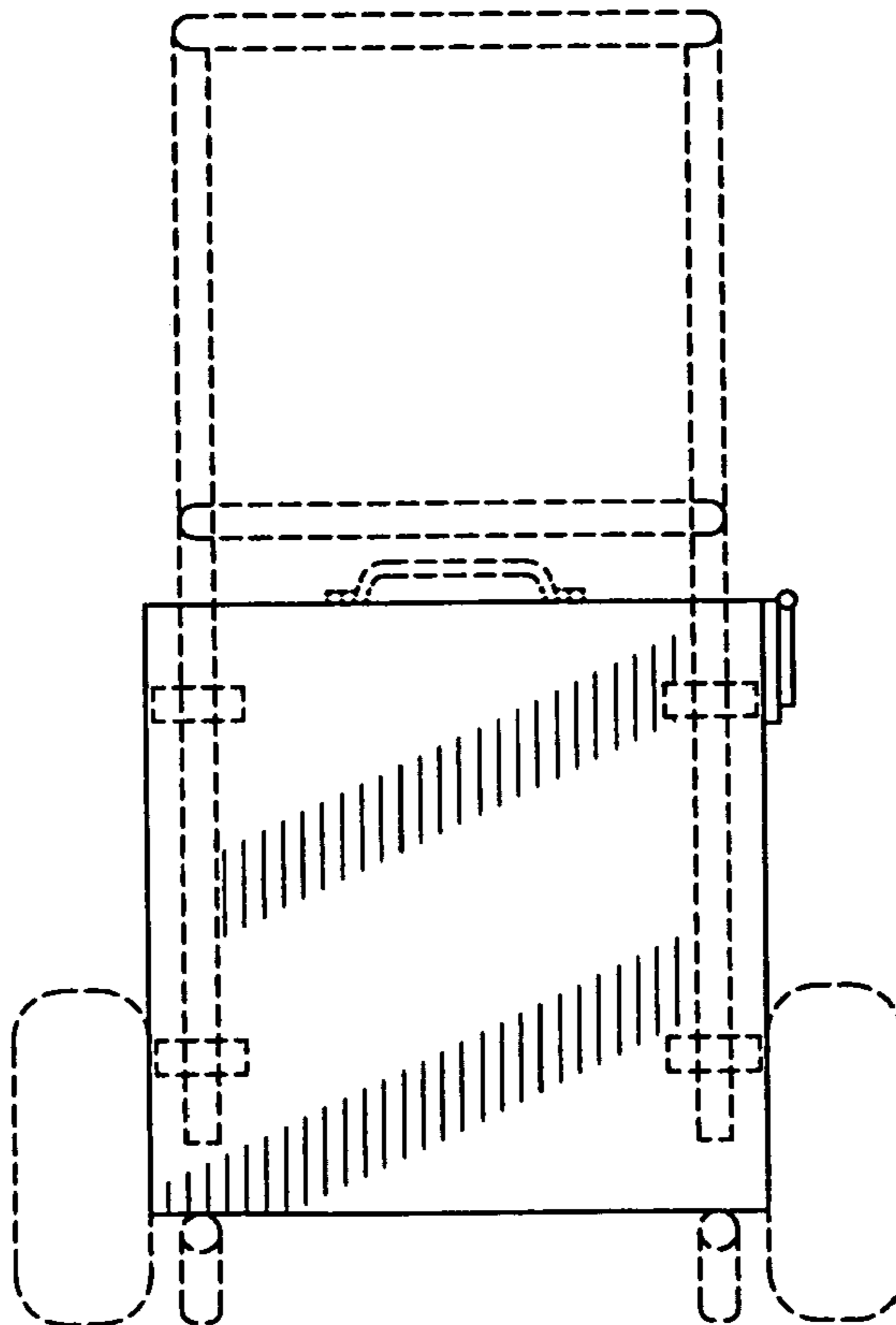

FIG. 3



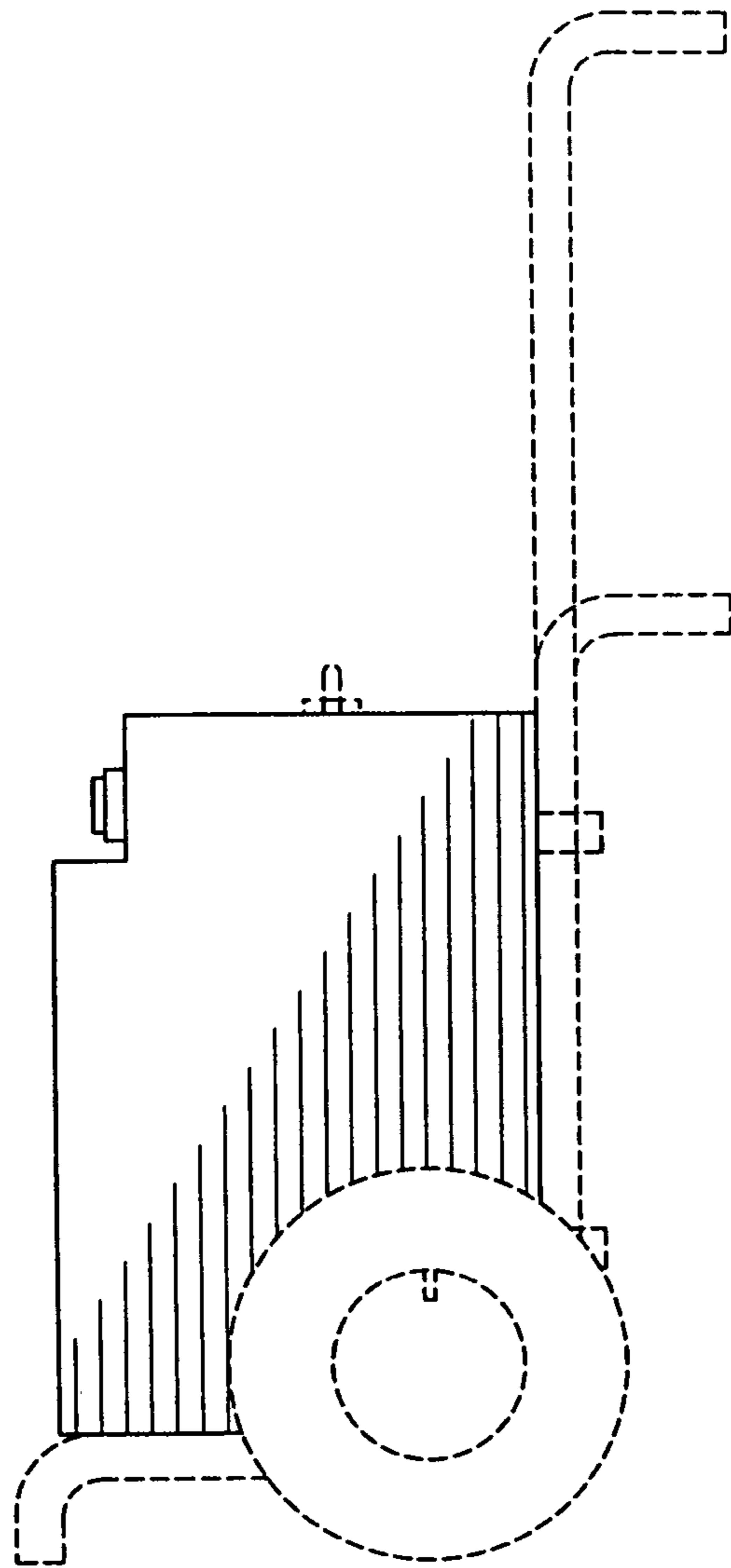
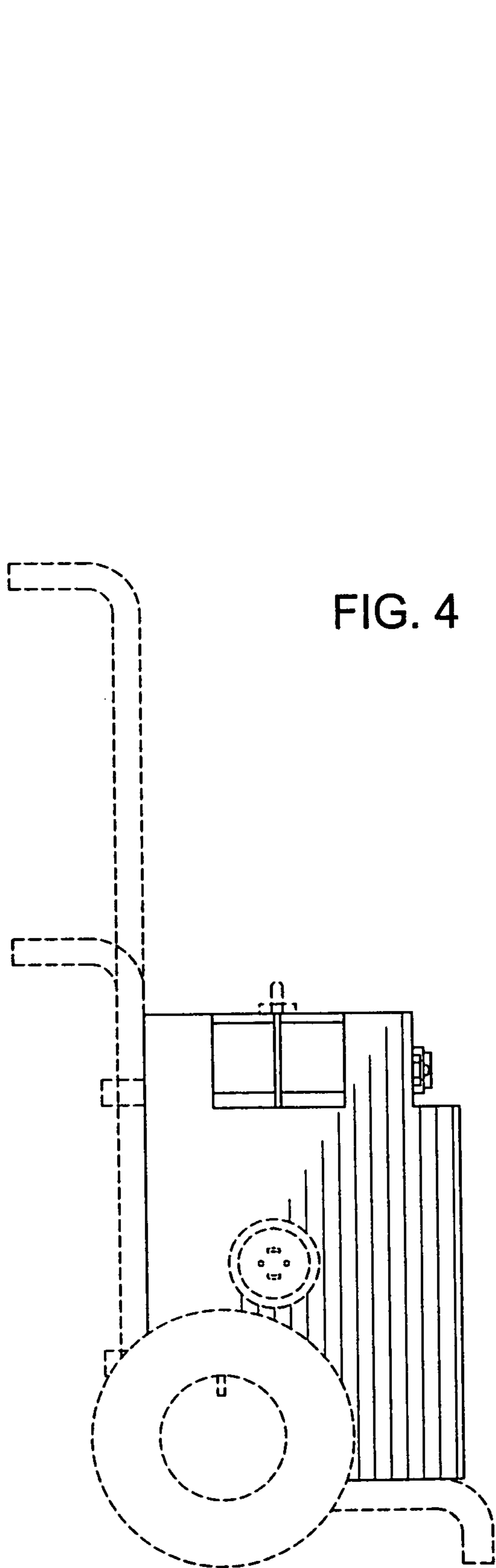

FIG. 4

FIG. 5

FIG. 6

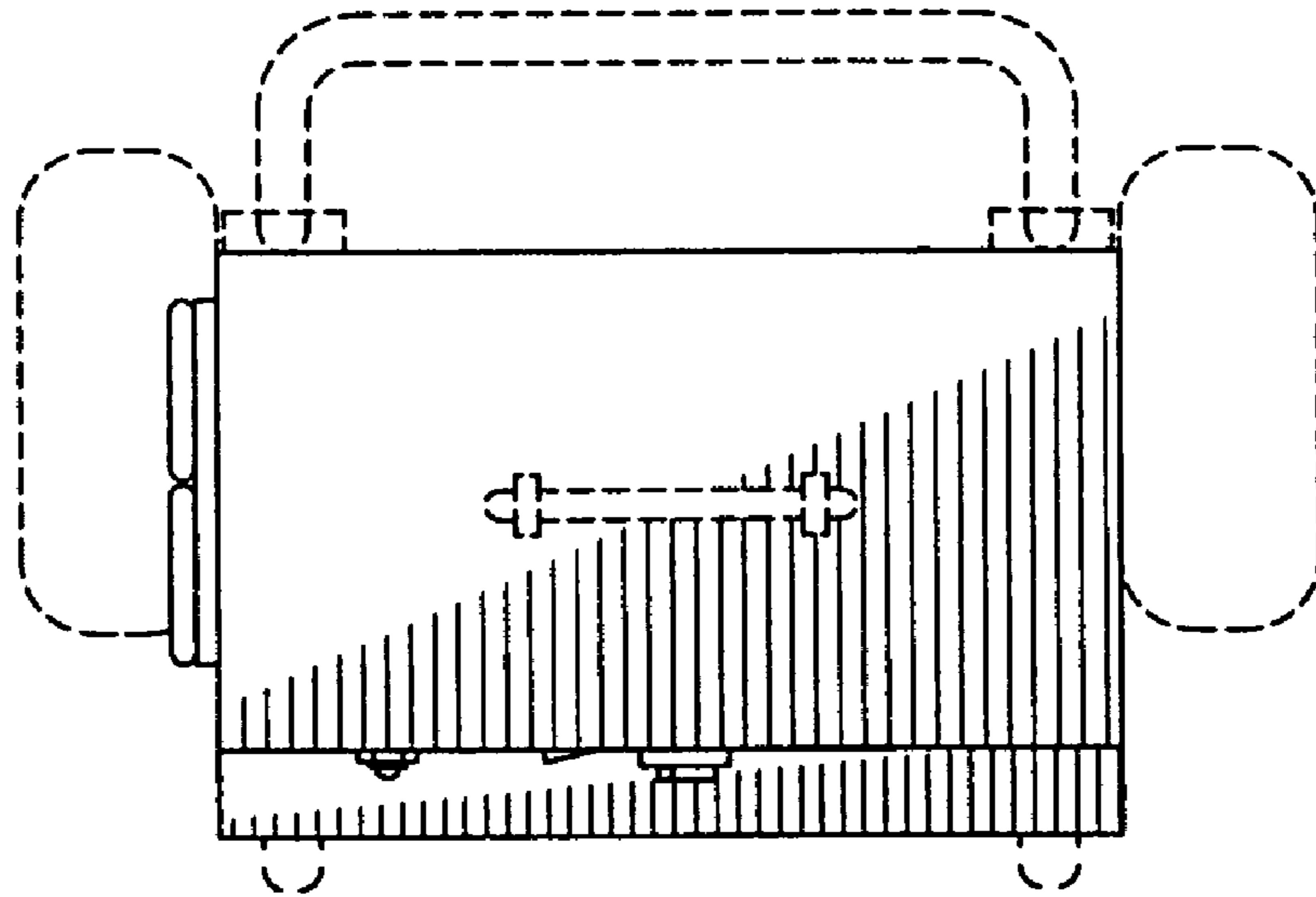

FIG. 7

