



US00D567318S

(12) **United States Design Patent**  
**Farrelly et al.**

(10) **Patent No.:** **US D567,318 S**

(45) **Date of Patent:** **\*\* Apr. 22, 2008**

(54) **PERSONAL TRANSPORTATION DEVICE**

(75) Inventors: **Ryan Farrelly**, San Diego, CA (US);  
**Jason Galoob**, Playa Del Rey, CA (US)

(73) Assignee: **Freeline Sports, Inc.**, San Diego, CA (US)

(\*\*) Term: **14 Years**

(21) Appl. No.: **29/279,978**

(22) Filed: **May 11, 2007**

**Related U.S. Application Data**

(63) Continuation of application No. 11/386,822, filed on Mar. 23, 2006.

(51) **LOC (8) Cl.** ..... **21-02**

(52) **U.S. Cl.** ..... **D21/763**

(58) **Field of Classification Search** ..... D21/760,  
D21/763, 765, 771, 779; 280/841, 11.115,  
280/11.14, 11.19, 11.221, 11.233, 11.25,  
280/809, 811, 87.01, 87.041, 87.042  
See application file for complete search history.

(56) **References Cited**

**U.S. PATENT DOCUMENTS**

D143,983 S \* 2/1946 Miller ..... D21/763  
D233,619 S \* 11/1974 Kelling ..... D21/763  
D505,469 S \* 5/2005 Joung et al. .... D21/765

D535,714 S \* 1/2007 Cheng et al. .... D21/763  
2003/0137116 A1 \* 7/2003 Shih ..... 280/11.19  
2004/0041359 A1 \* 3/2004 Im ..... 280/11.25

**FOREIGN PATENT DOCUMENTS**

WO WO 2006/059883 A1 6/2006

\* cited by examiner

*Primary Examiner*—Holly H. Baynham

*Assistant Examiner*—Cynthia M. Chin

(74) *Attorney, Agent, or Firm*—Ganz Law, P.C.

(57) **CLAIM**

The ornamental design for a personal transportation device, as shown and described.

**DESCRIPTION**

FIG. 1 is an isometric view of the personal transportation device.

FIG. 2 is a top view of the personal transportation device.

FIG. 3 is a side view of the personal transportation device.

FIG. 4 is a bottom view of the personal transportation device; and,

FIG. 5 is an end view of the personal transportation device.

The broken lines are for illustrative purposes only and form no part of the claimed design.

**1 Claim, 3 Drawing Sheets**

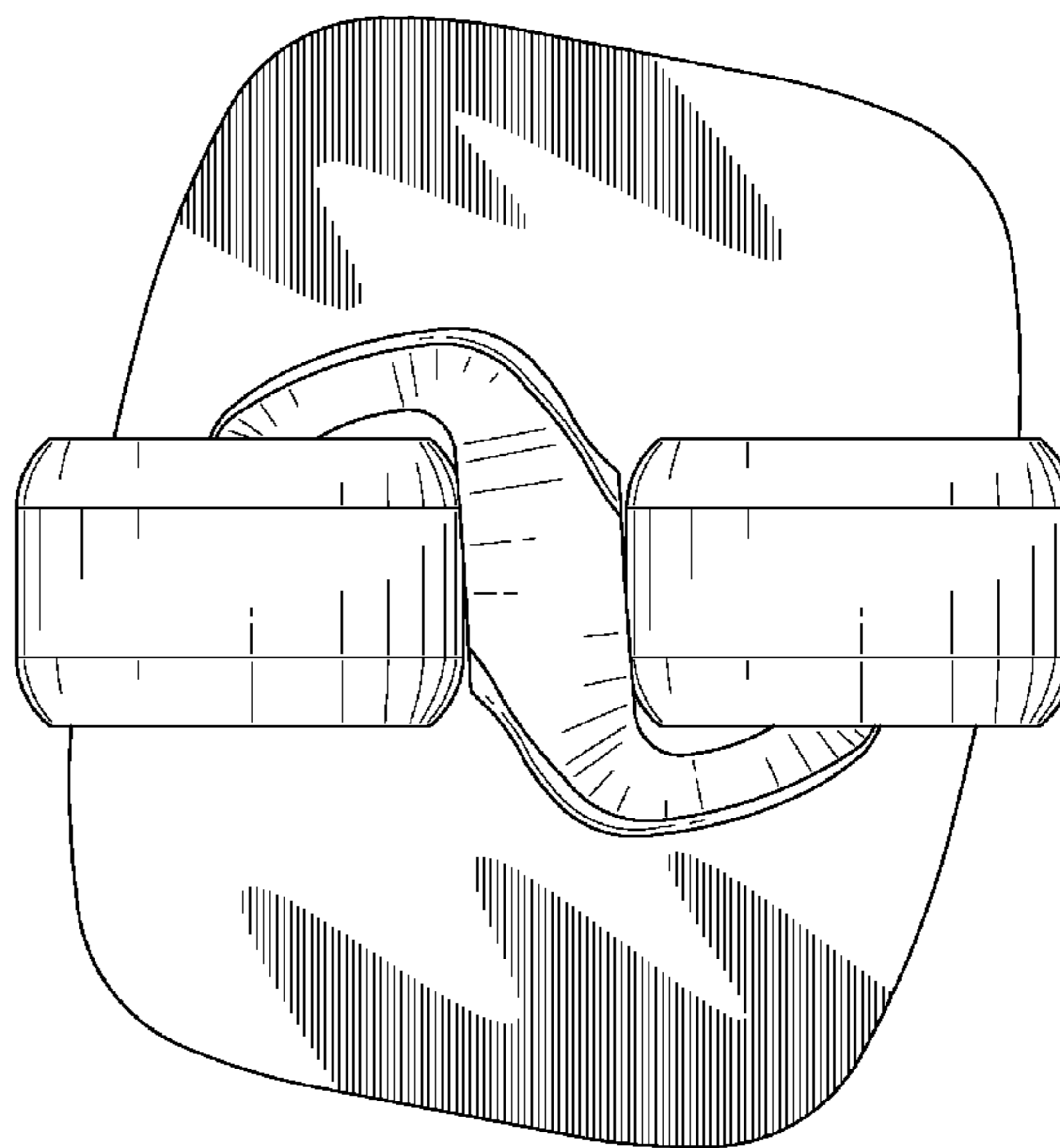
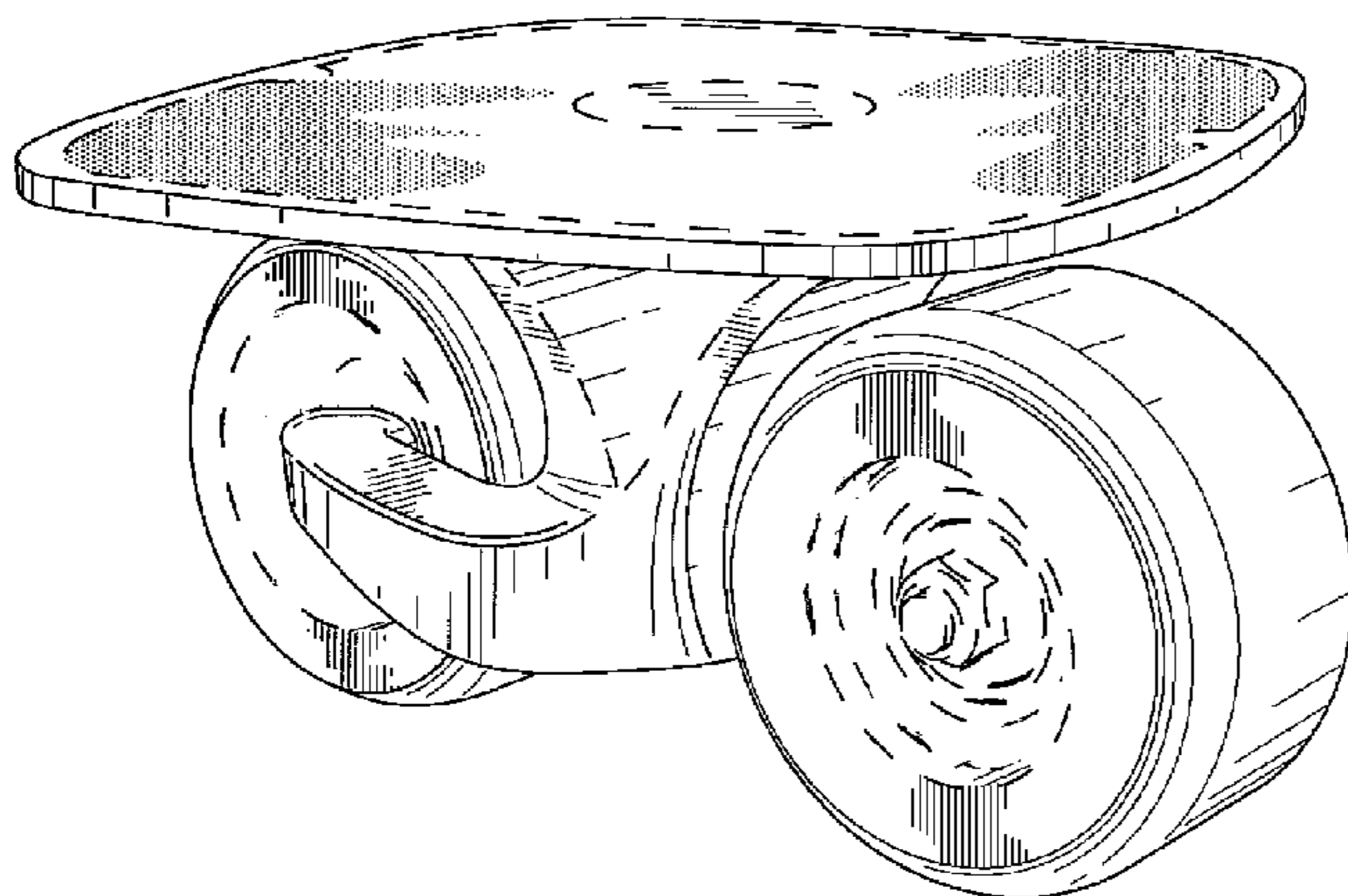

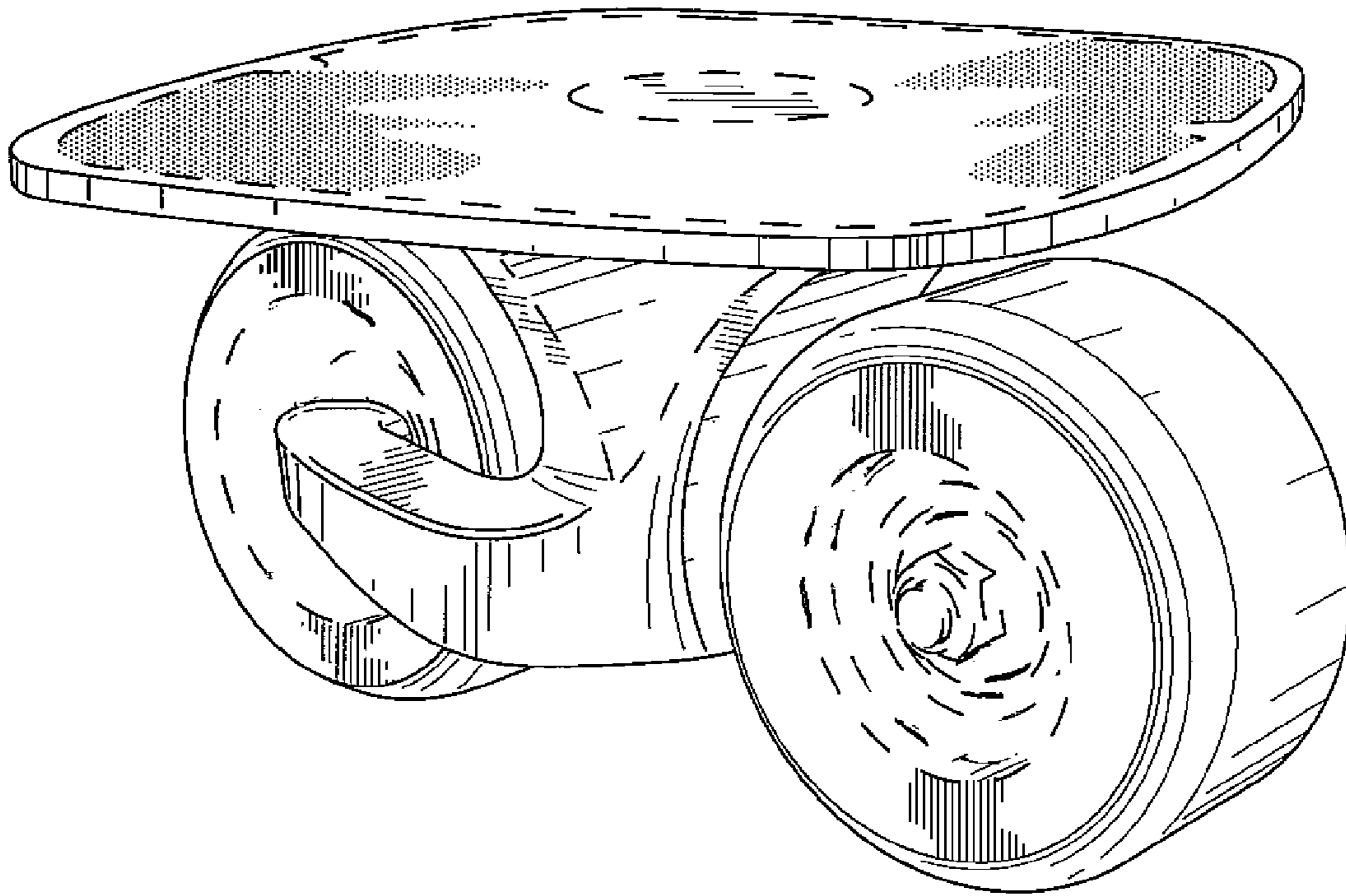

FIG. 1

FIG. 2

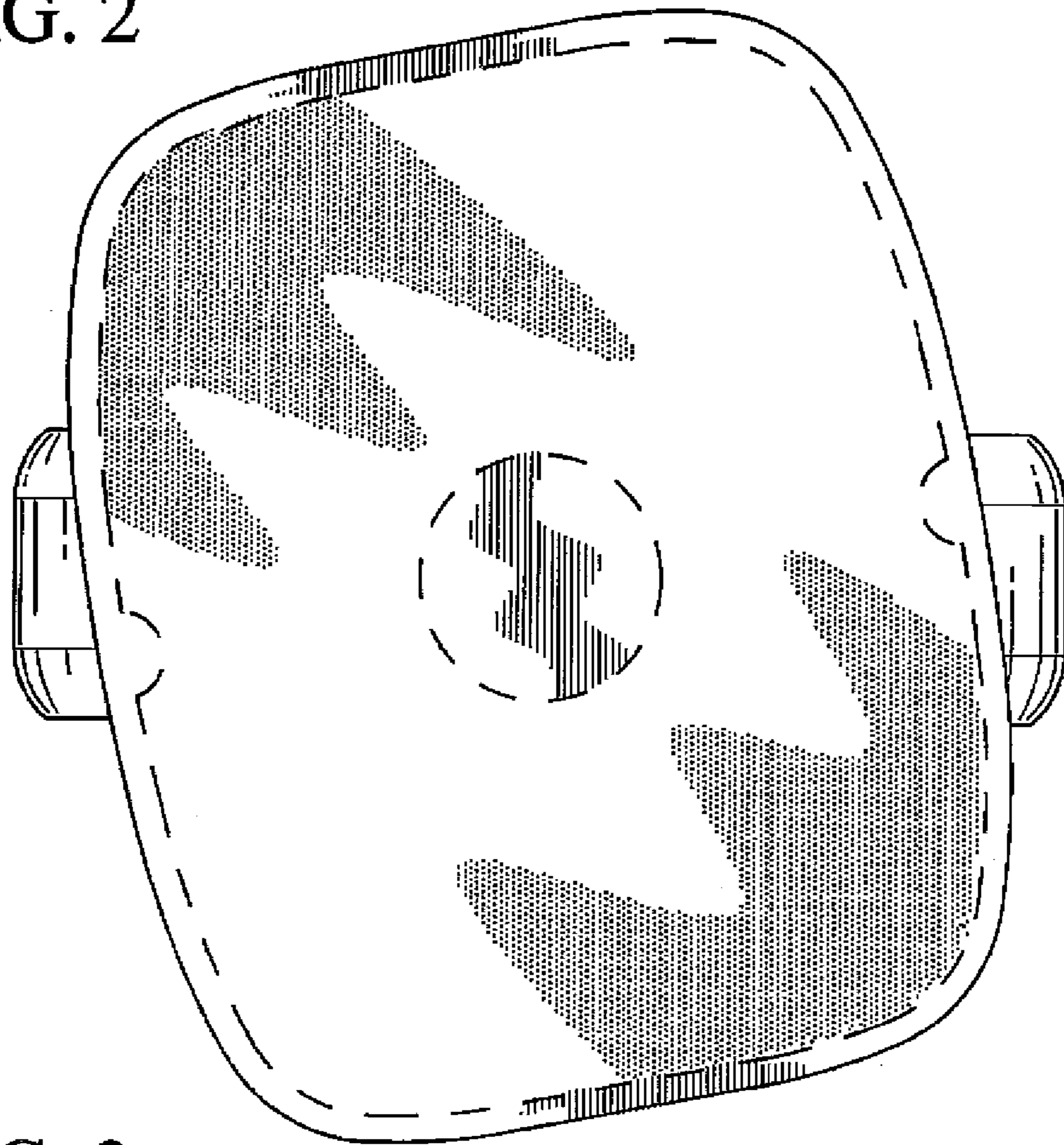

FIG. 3

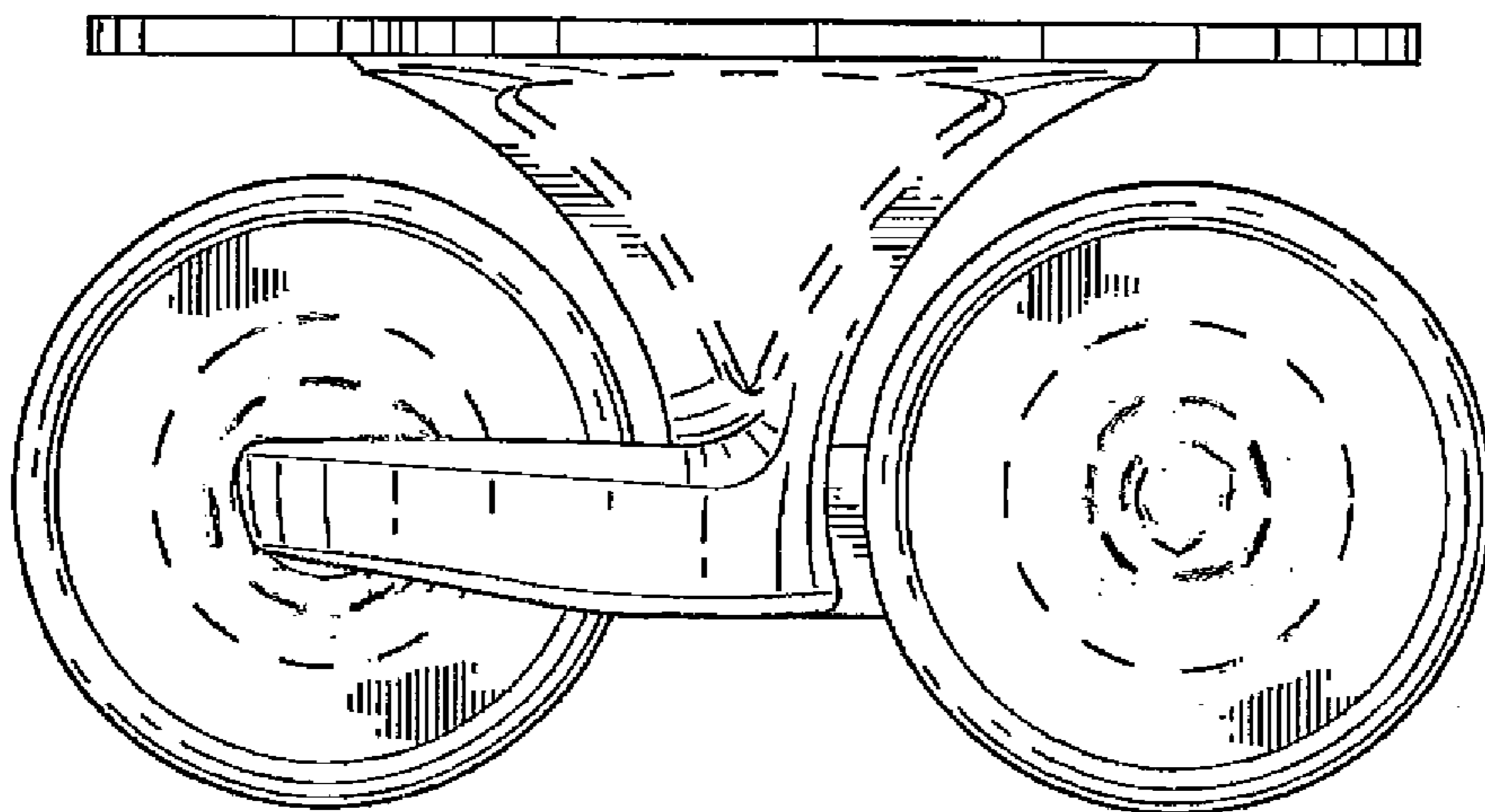

FIG. 4

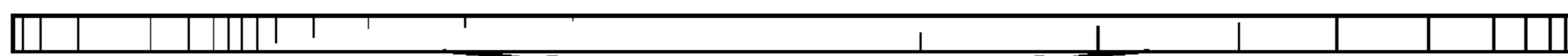
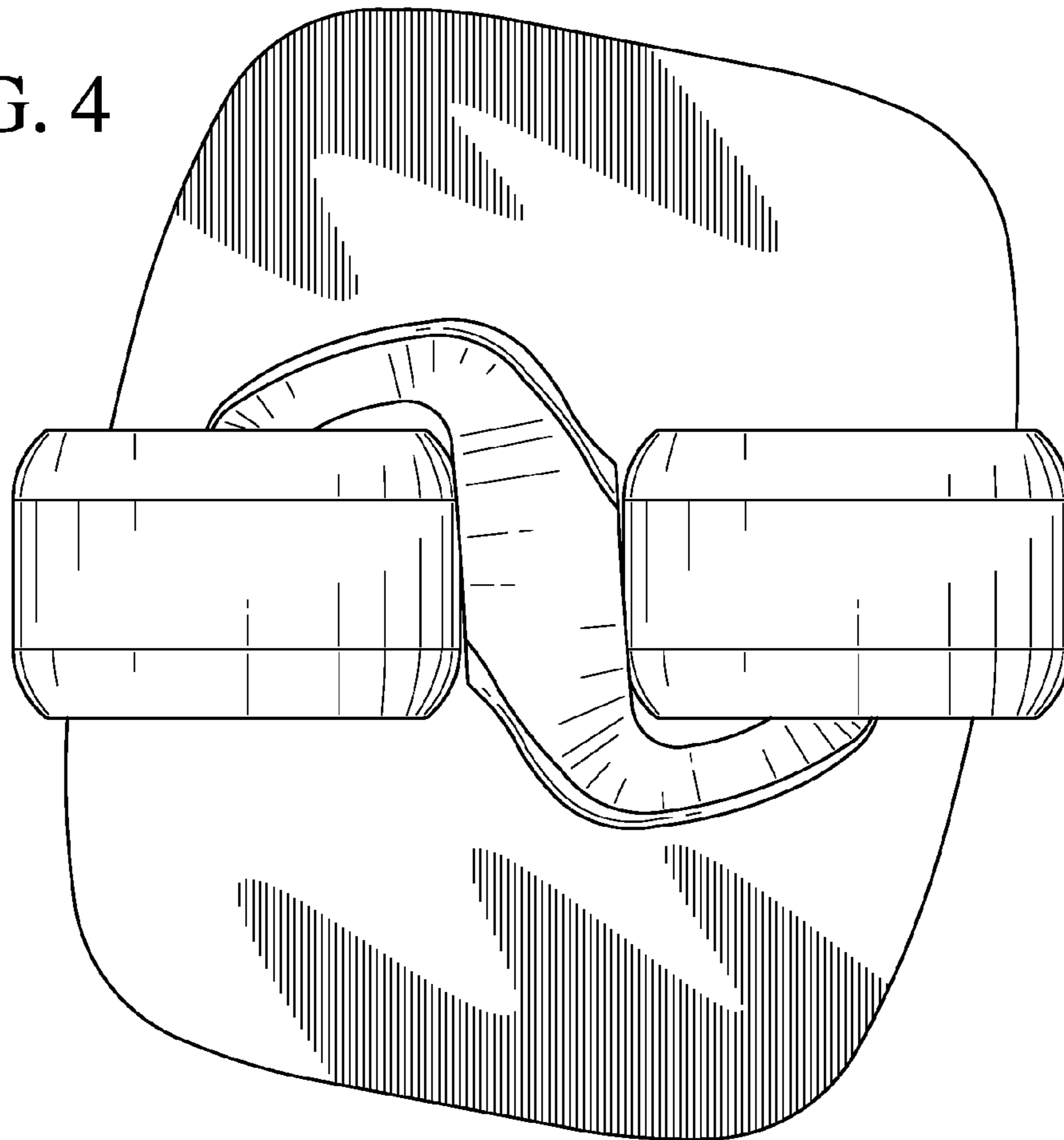

FIG. 5

