



US00D567122S

(12) **United States Design Patent**
Lee

(10) **Patent No.:** **US D567,122 S**
(45) **Date of Patent:** **** Apr. 22, 2008**

(54) **TAPE MEASURE**

(76) **Inventor:** **Shih-Lin Lee**, 1F, No. 22, Lane 81,
Sec. 2, Tunhwa S. Rd., Taipei (TW)

(**) **Term:** **14 Years**

(21) **Appl. No.:** **29/282,019**

(22) **Filed:** **Jul. 10, 2007**

(51) **LOC (8) Cl.** **10-04**

(52) **U.S. Cl.** **D10/72**

(58) **Field of Classification Search** D10/72;
33/668, 755-771; 242/292, 381.1, 381.2,
242/381.3, 381.4, 381.5, 381.6

See application file for complete search history.

(56) **References Cited**

U.S. PATENT DOCUMENTS

4,687,155 A *	8/1987	Burton	242/381
6,382,547 B1 *	5/2002	Yang	33/769
D503,638 S *	4/2005	Lin	D10/72
D504,836 S *	5/2005	Wang	D10/72

* cited by examiner

Primary Examiner—Antoine D. Davis

(74) *Attorney, Agent, or Firm*—Ming Chow; Sinorica, LLC

(57) **CLAIM**

The ornamental design for a tape measure, as shown and described.

DESCRIPTION

FIG. 1 is a front right perspective view of a tape measure showing my new design;

FIG. 2 is a front perspective view thereof;

FIG. 3 is a rear perspective view thereof;

FIG. 4 is a left side elevation view thereof;

FIG. 5 is a right side elevation view thereof;

FIG. 6 is a top plan view thereof; and,

FIG. 7 is a bottom plan view thereof.

1 Claim, 4 Drawing Sheets

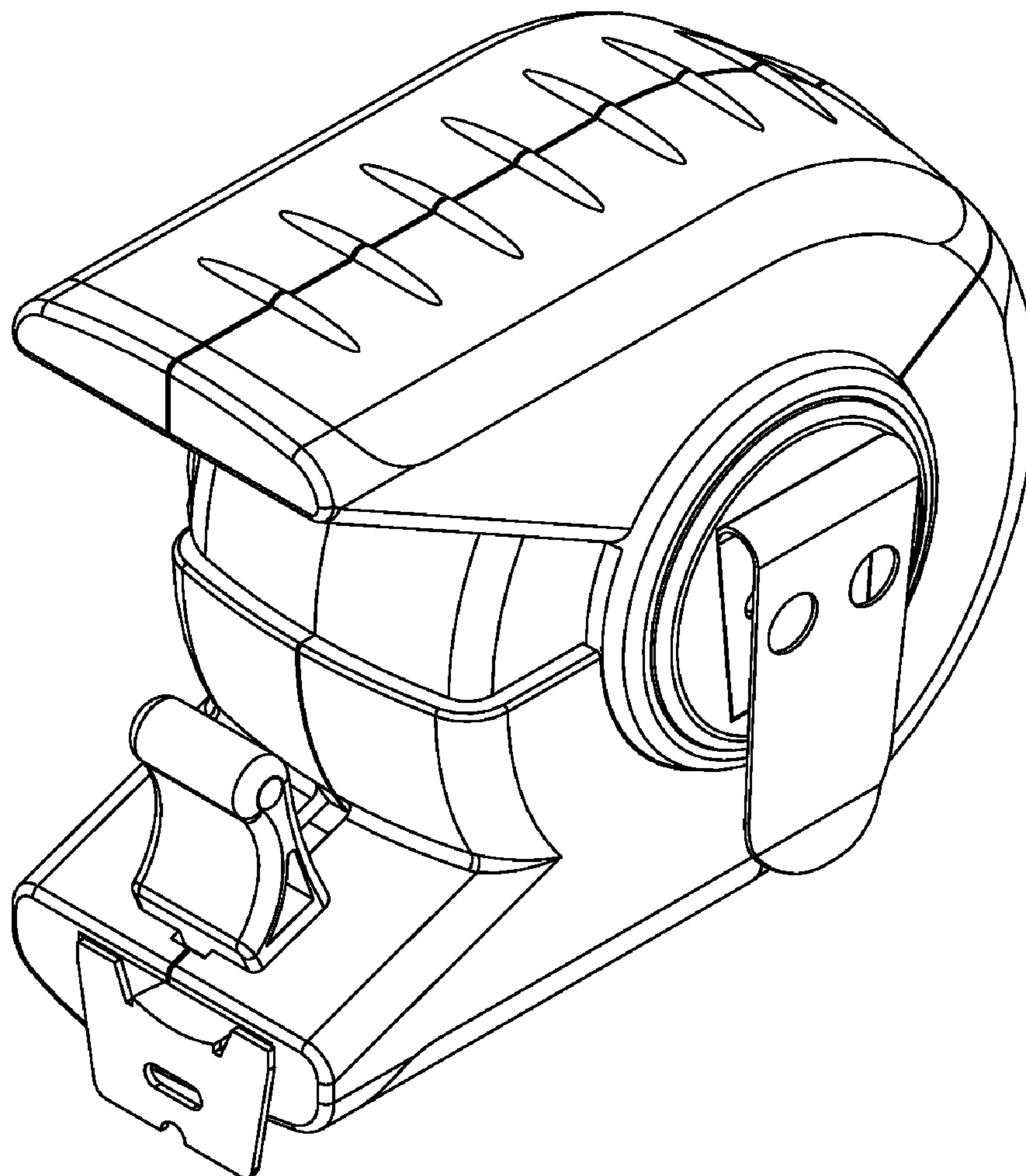

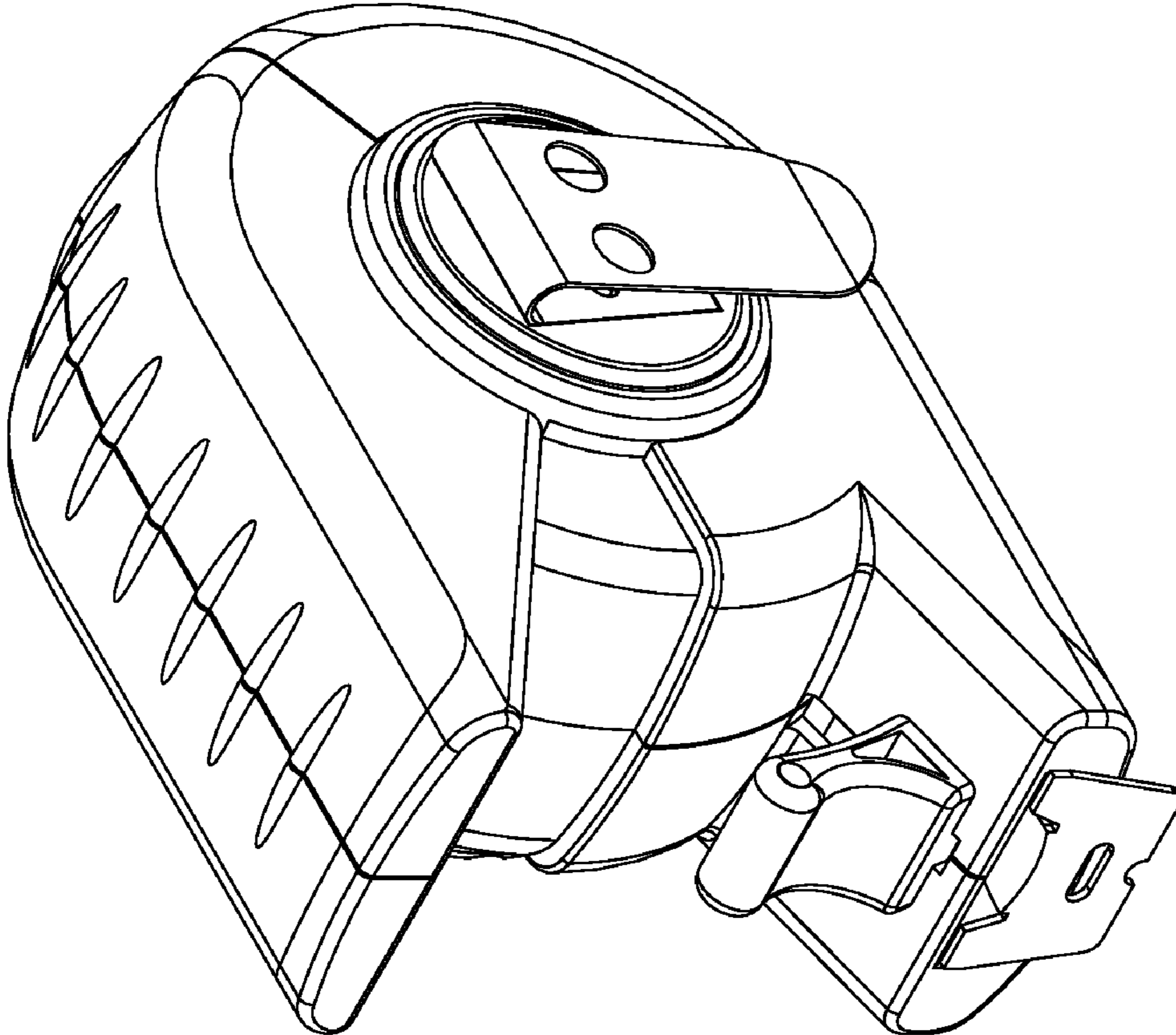

FIG. 1

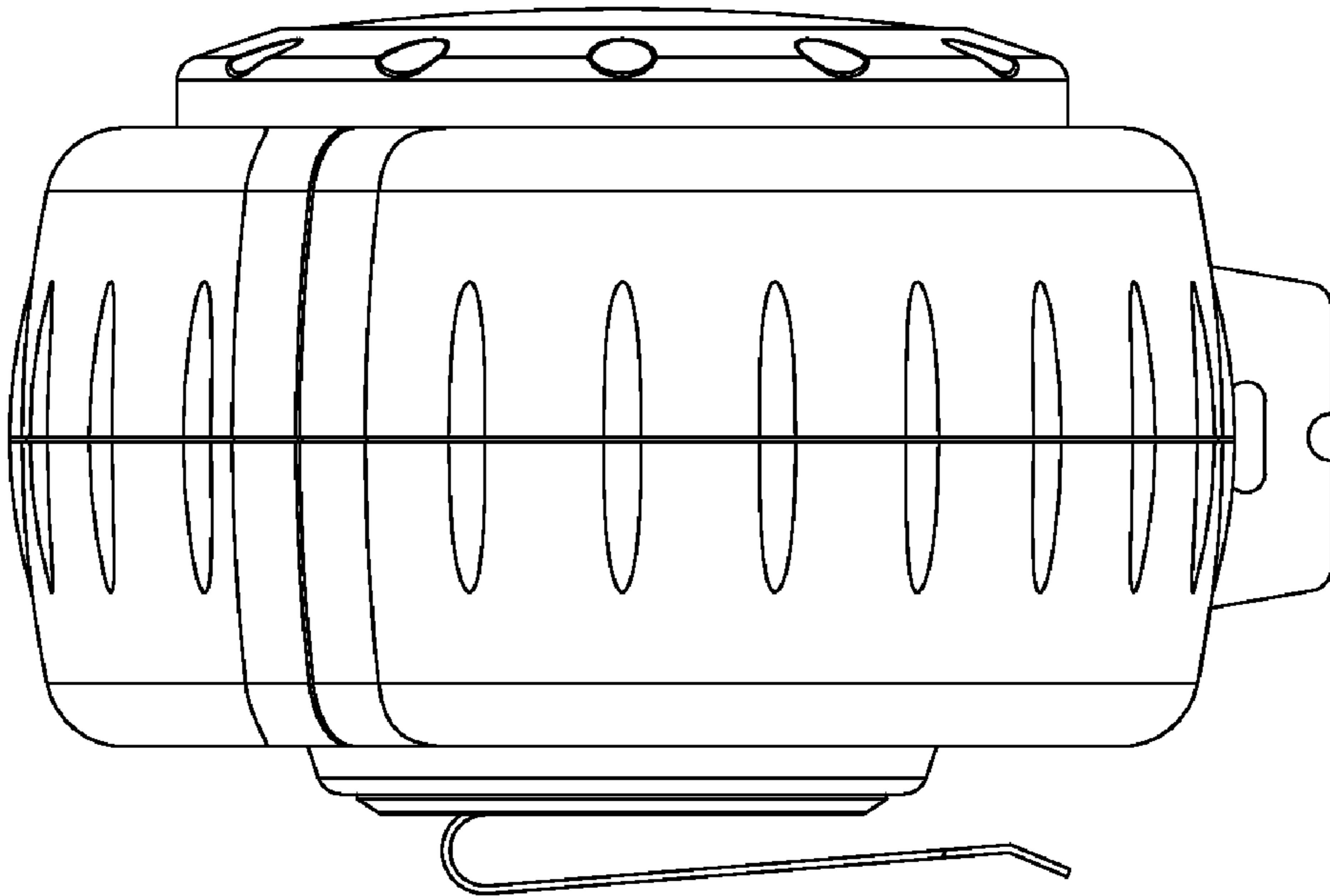

FIG. 3

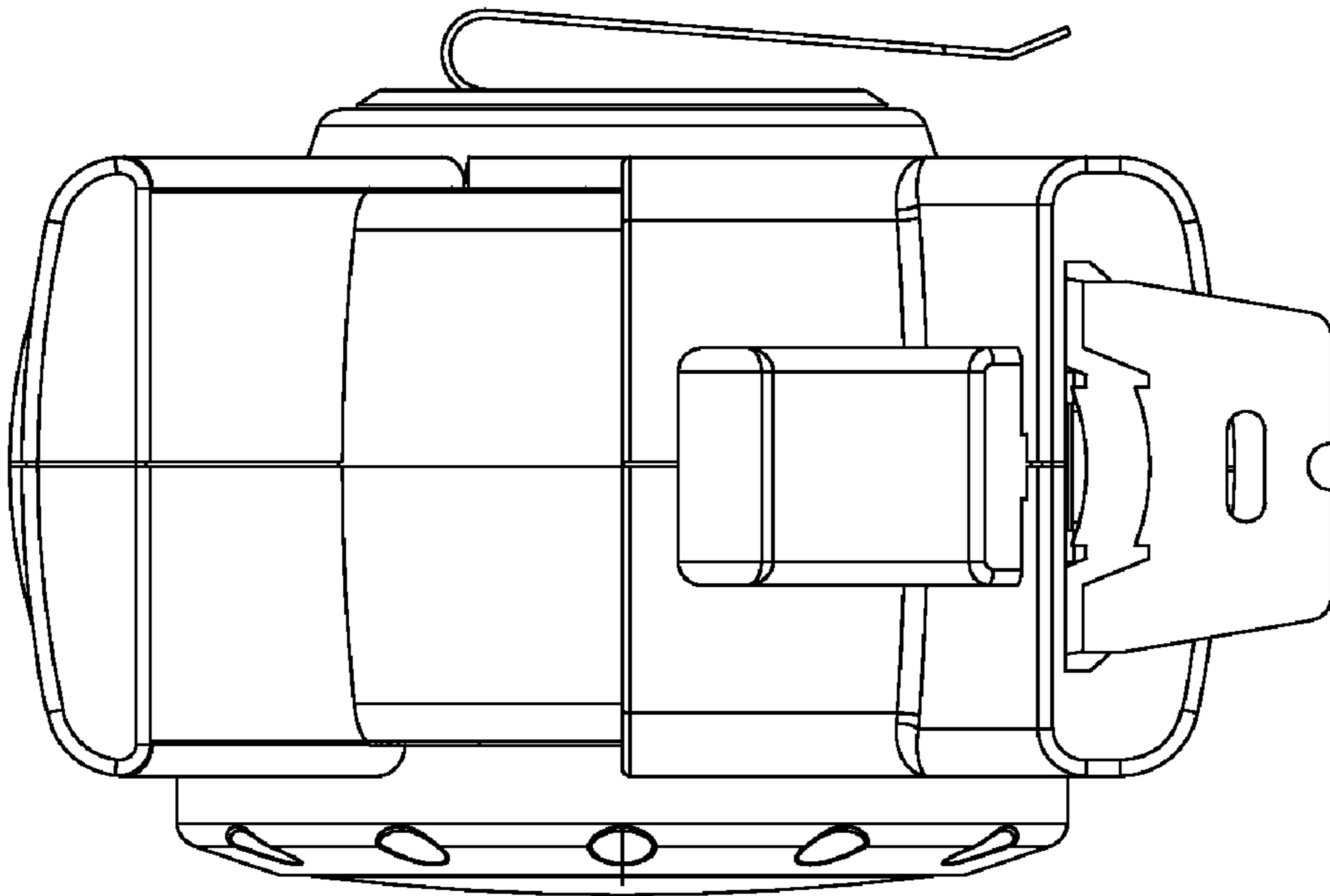

FIG. 2

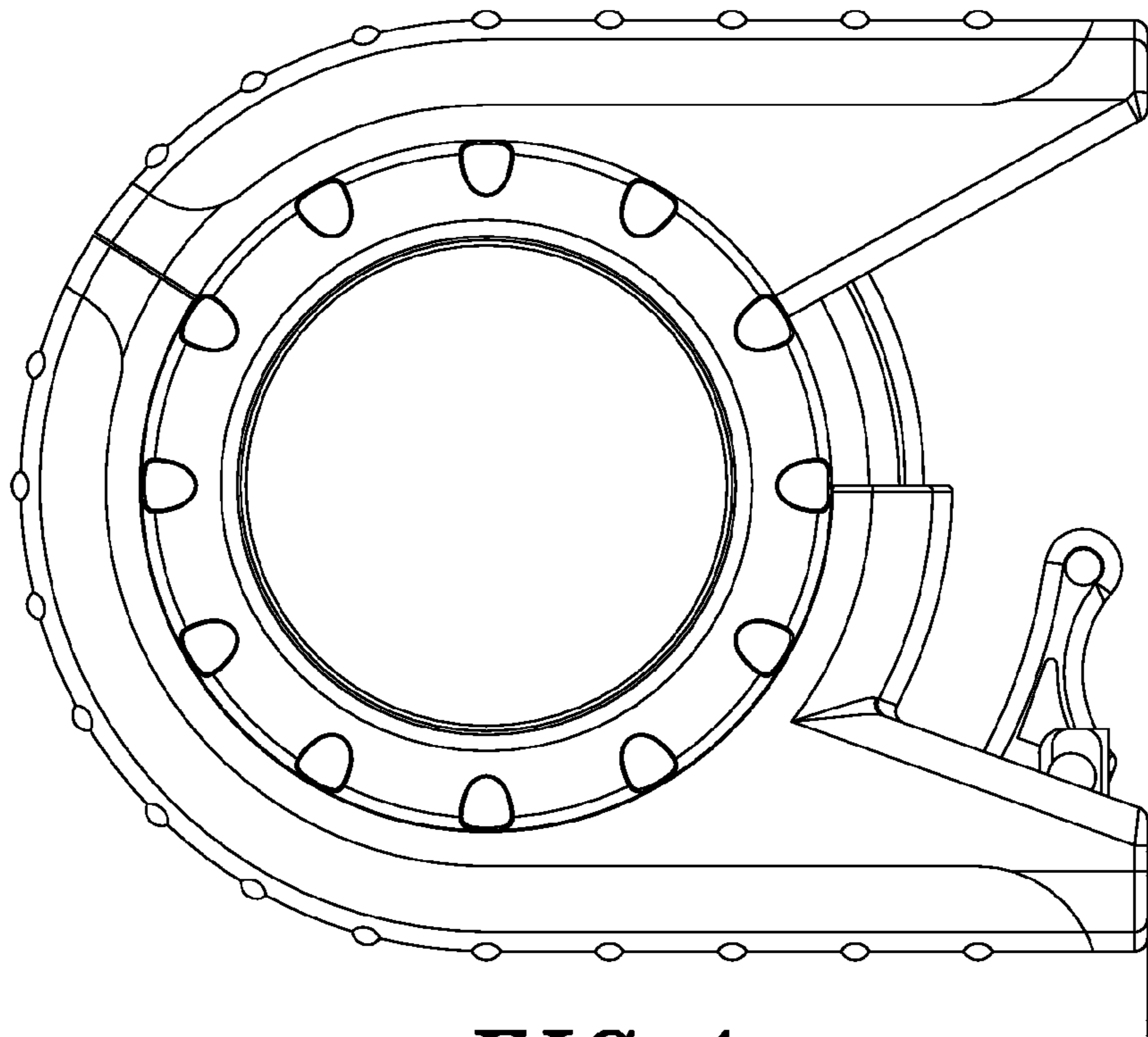

FIG. 4

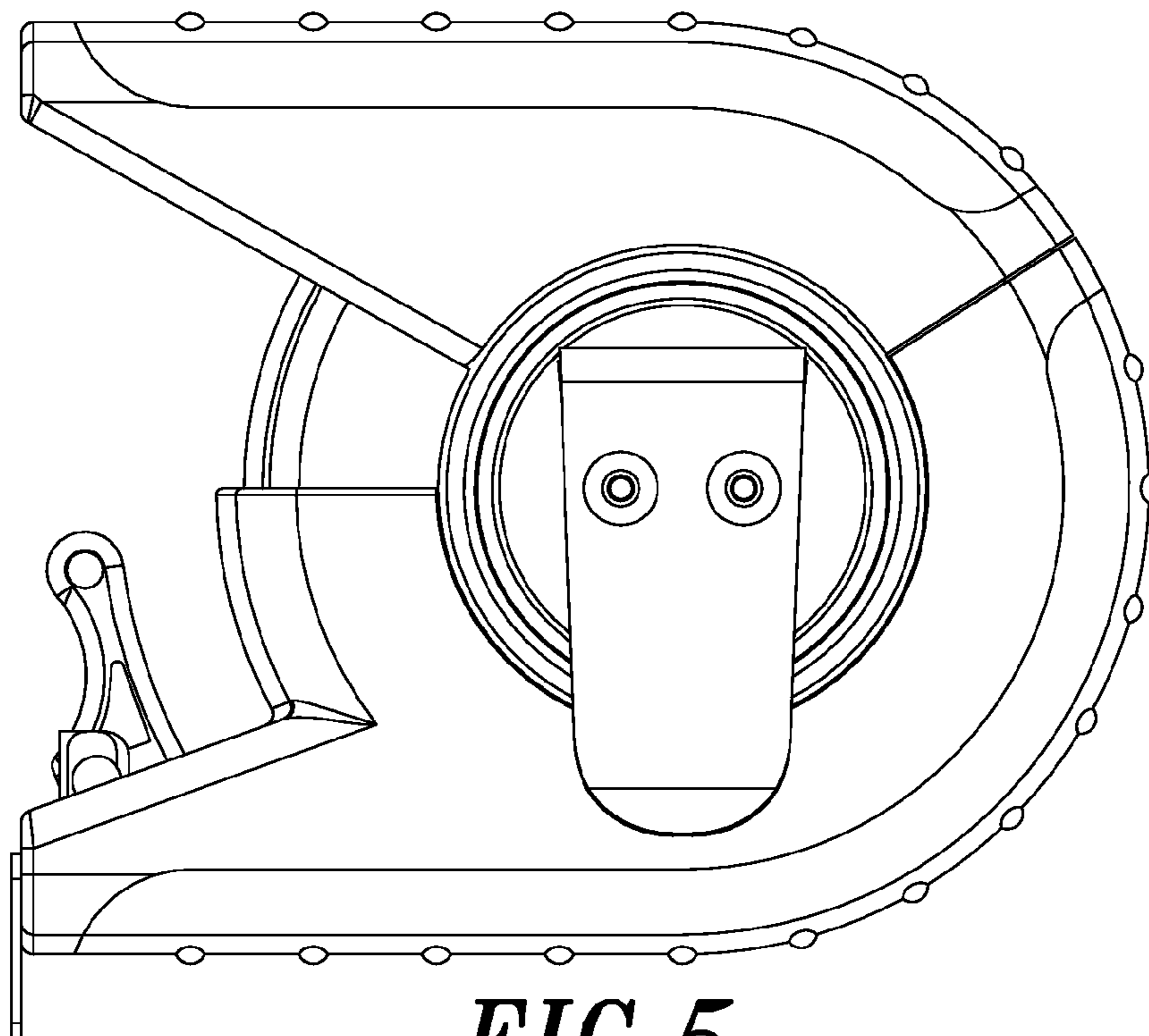

FIG. 5

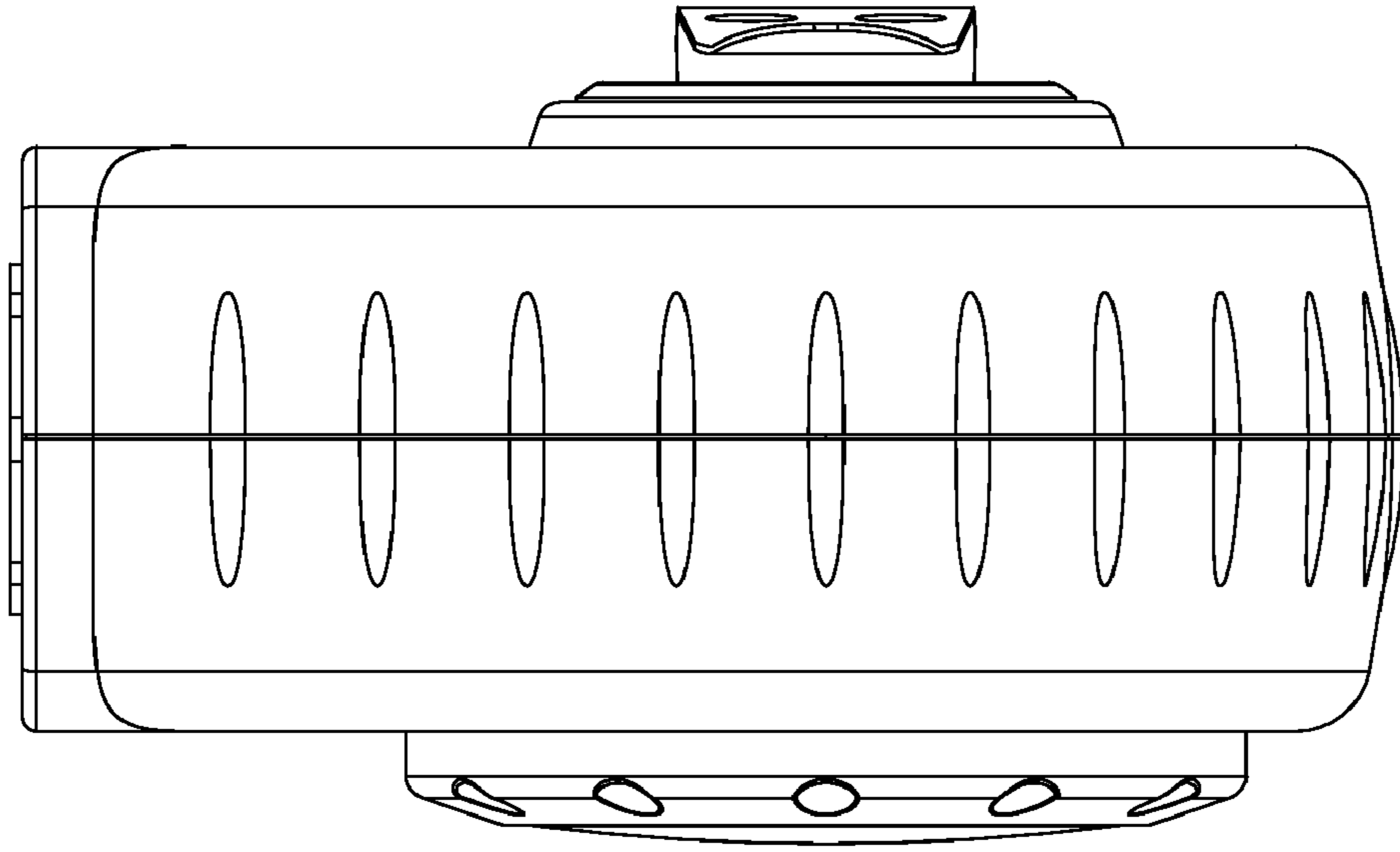

FIG. 7

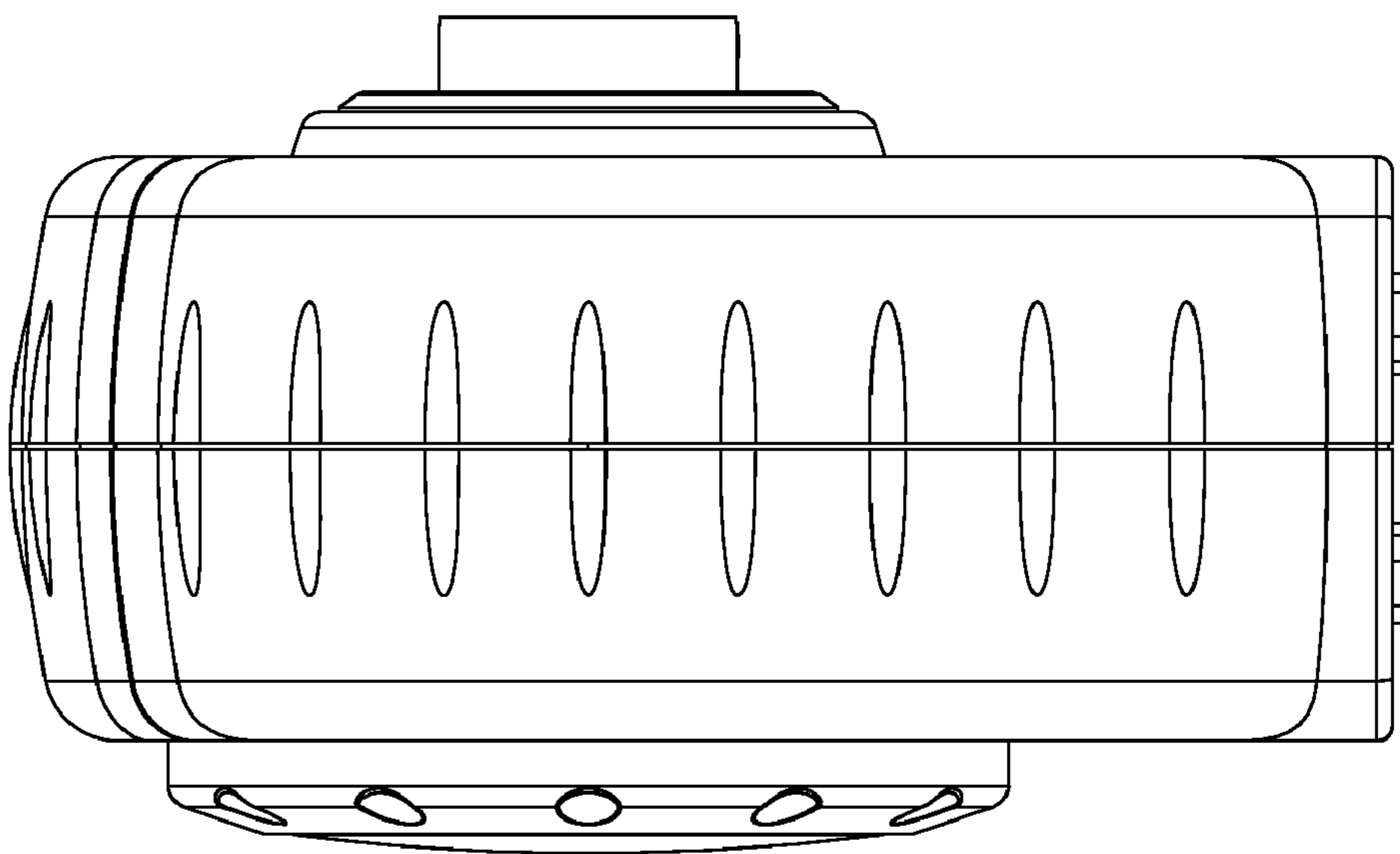

FIG. 6