



US00D567071S

(12) **United States Design Patent**  
**Carney**

(10) **Patent No.:** **US D567,071 S**  
(45) **Date of Patent:** **\*\* Apr. 22, 2008**

(54) **PIVOTING CONNECTOR**

WO WO 2006016096 2/2006

(75) Inventor: **John Carney**, Warrington (GB)

(73) Assignee: **Cheshire Mouldings & Woodturnings Limited**, Warrington, Cheshire (GB)

(\*\*) Term: **14 Years**

(21) Appl. No.: **29/261,211**

(22) Filed: **Jun. 9, 2006**

(30) **Foreign Application Priority Data**

Apr. 10, 2006 (EM) ..... 000512421

(51) **LOC (8) Cl.** ..... **08-08**

(52) **U.S. Cl.** ..... **D8/382**

(58) **Field of Classification Search** ..... D32/40;  
15/145, 229.2; D8/382, 380; 411/458, 461;  
52/480; D4/199

See application file for complete search history.

(56) **References Cited**

**U.S. PATENT DOCUMENTS**

- D387,910 S \* 12/1997 Berti ..... D4/199
- D416,474 S \* 11/1999 Wang ..... D8/382
- D420,279 S \* 2/2000 Wang ..... D8/382
- D420,280 S \* 2/2000 Wang ..... D8/382
- D420,894 S \* 2/2000 Wang ..... D8/382
- D485,159 S \* 1/2004 Junkers ..... D8/382
- D534,792 S \* 1/2007 Cooper ..... D8/382

**FOREIGN PATENT DOCUMENTS**

GB 2417042 2/2006

**OTHER PUBLICATIONS**

Search Report under Section 17 published Feb. 15, 2006 with UK Patent Application GB 2 417 042 A.

\* cited by examiner

*Primary Examiner*—Holly H. Baynham

*Assistant Examiner*—Sheryl Friedman

(74) *Attorney, Agent, or Firm*—Thompson Coburn LLP; Matthew J. Himich, Esq.

(57) **CLAIM**

The ornamental design for a pivoting connector, as shown and described.

**DESCRIPTION**

FIG. 1 is a perspective top view;

FIG. 2 is a back view;

FIG. 3 is a side view;

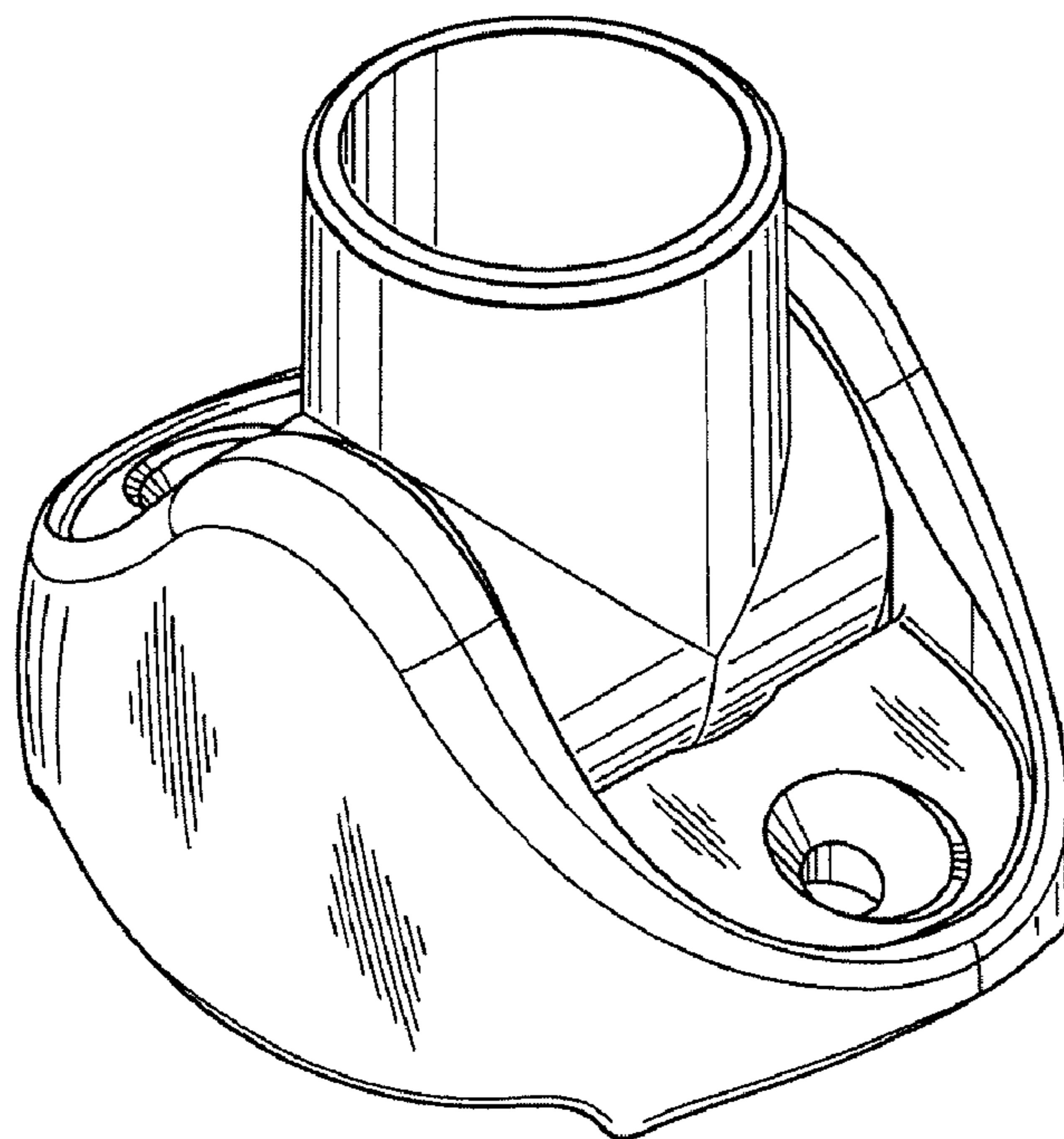
FIG. 4 is a top view;

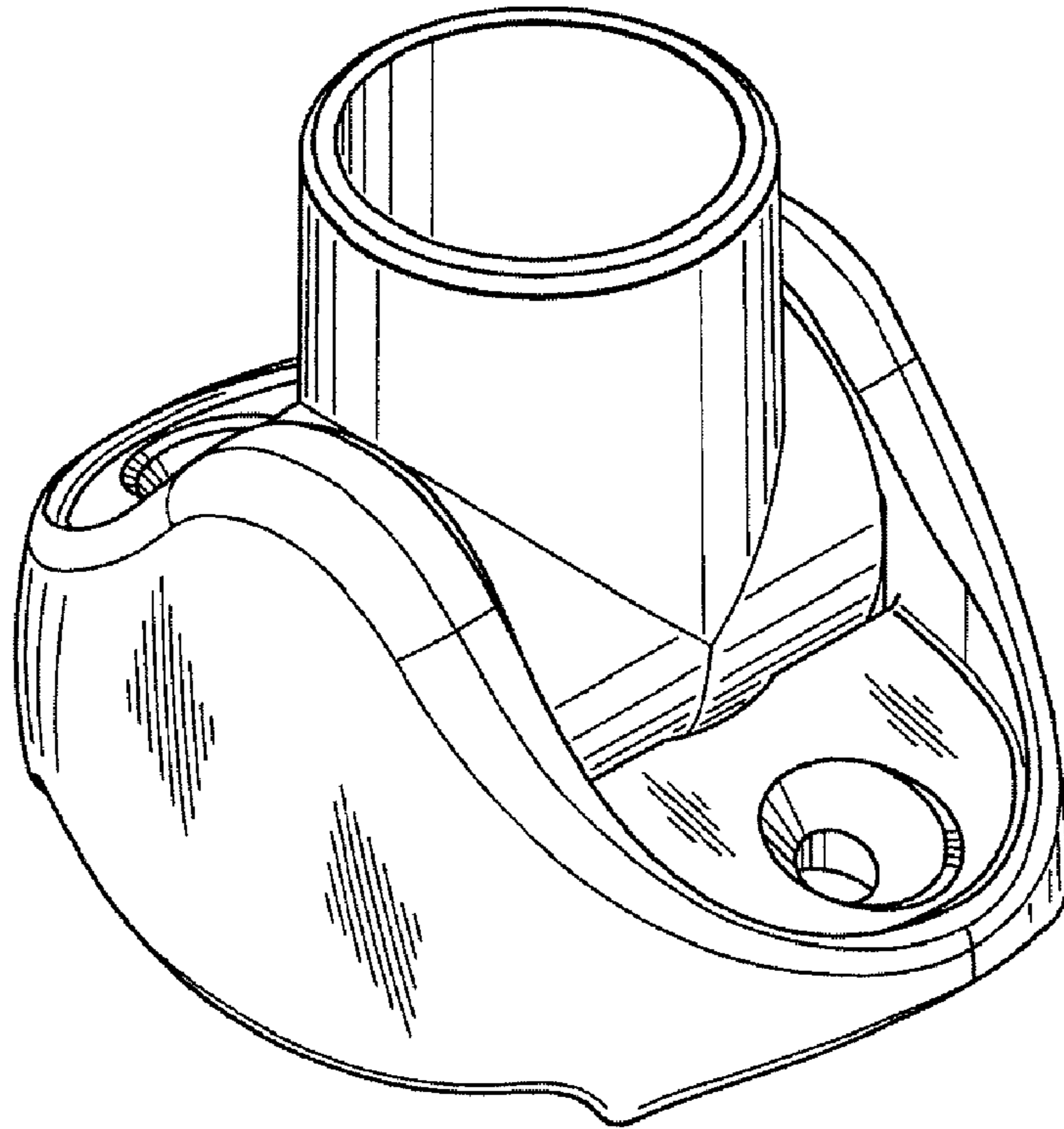
FIG. 5 is a front view;

FIG. 6 is a side view showing a first alternative position of a moveable part; and,

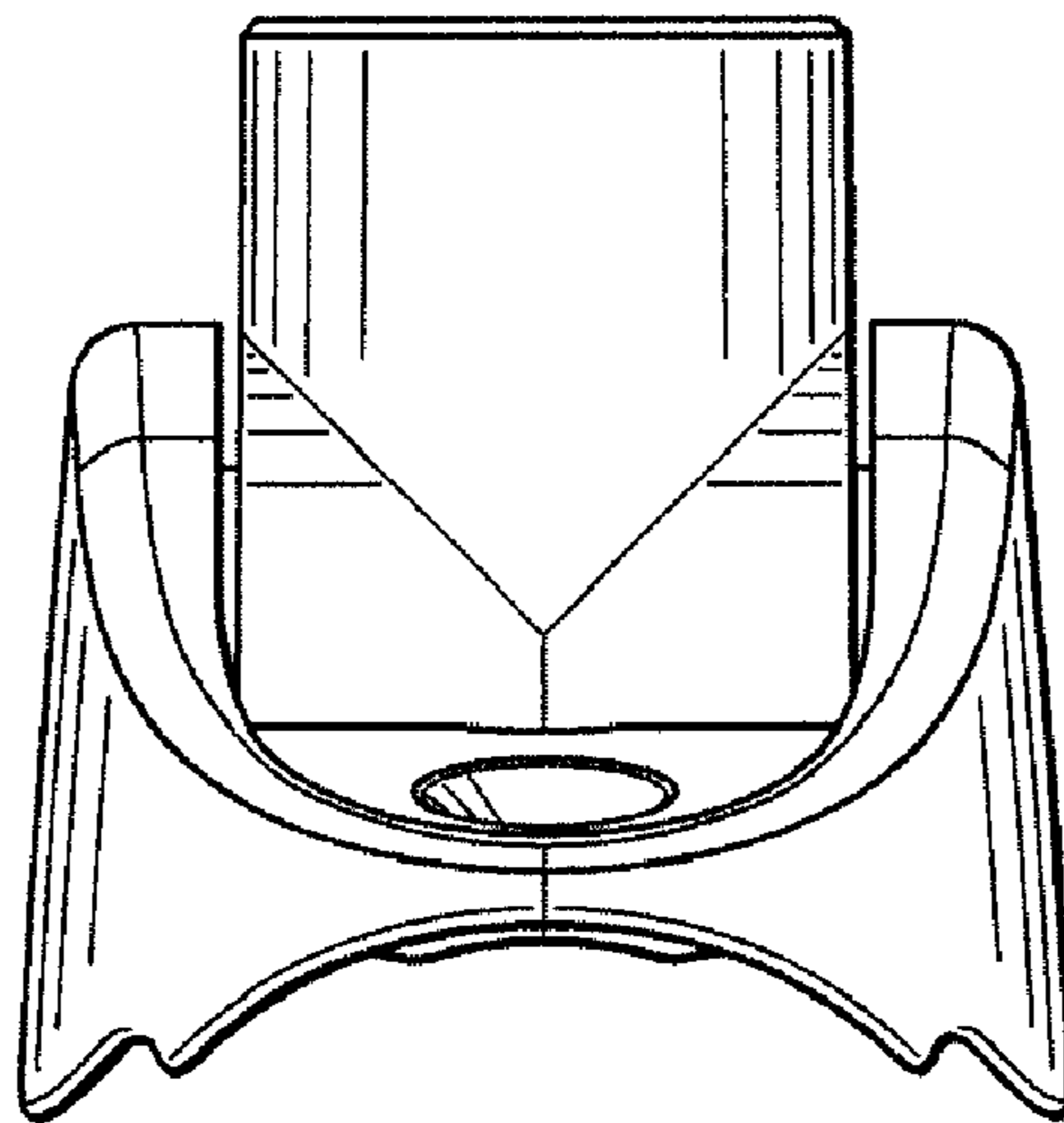
FIG. 7 is an opposite side view of FIG. 3.

**1 Claim, 3 Drawing Sheets**

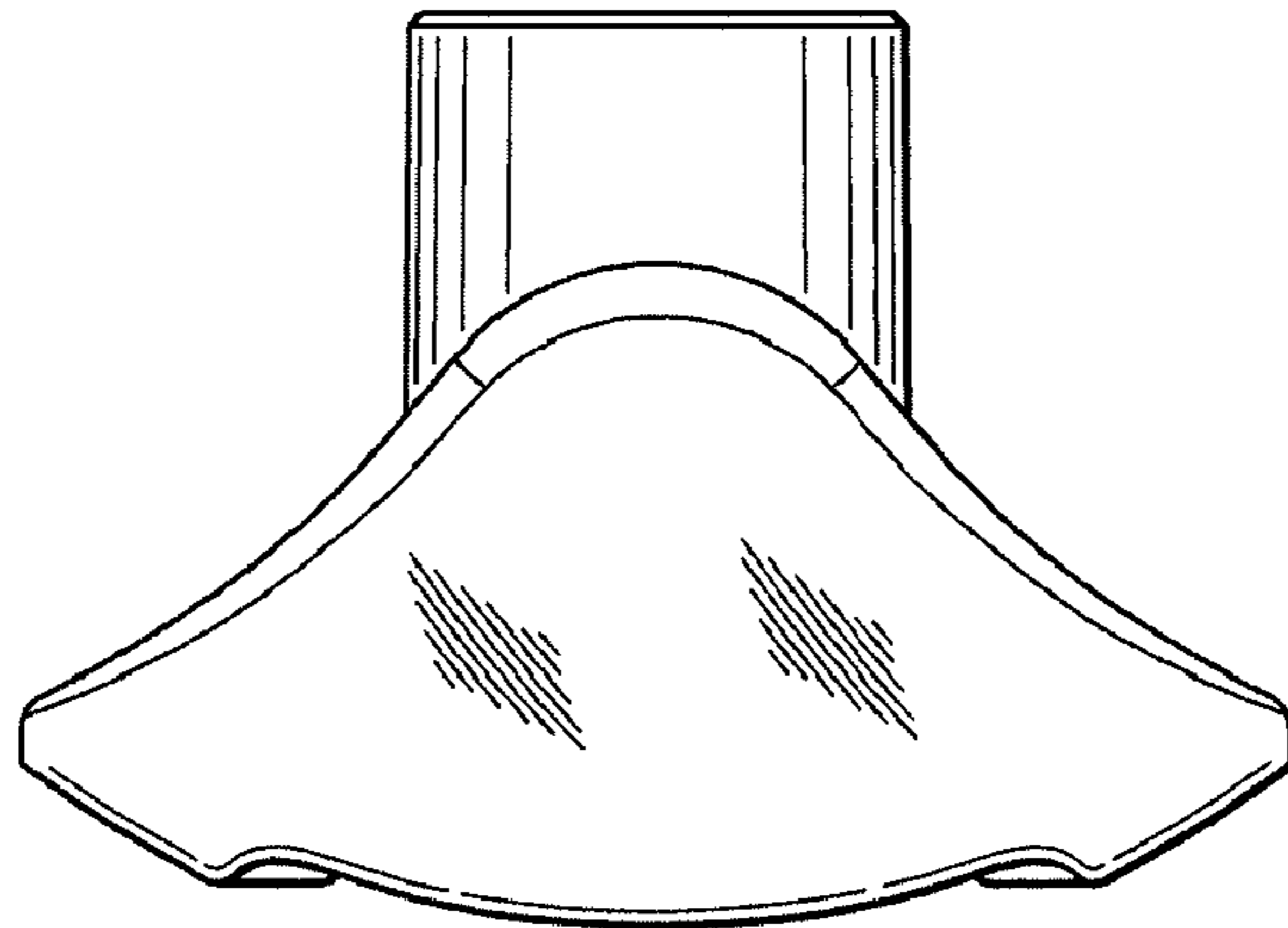




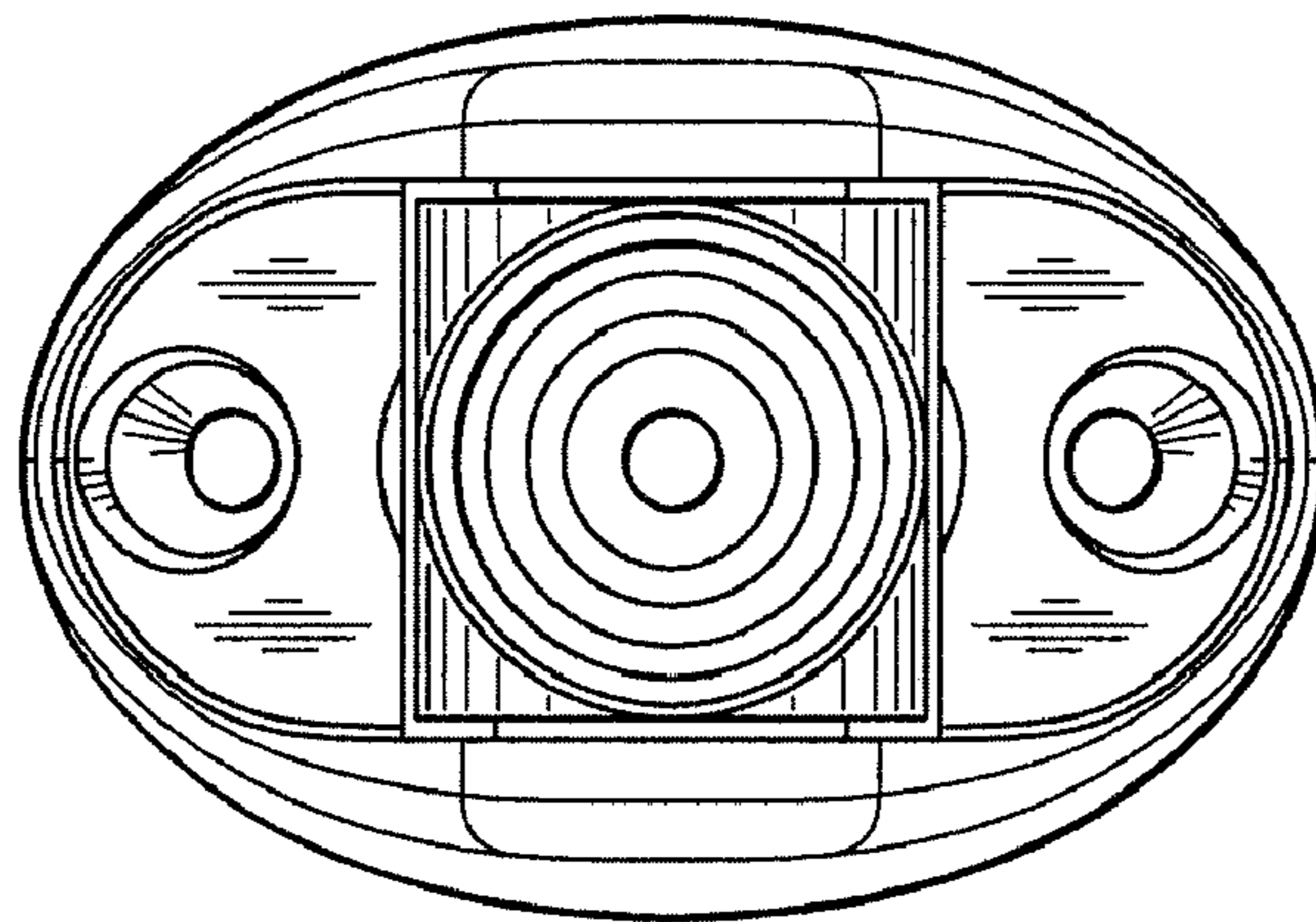
**Fig. 1**



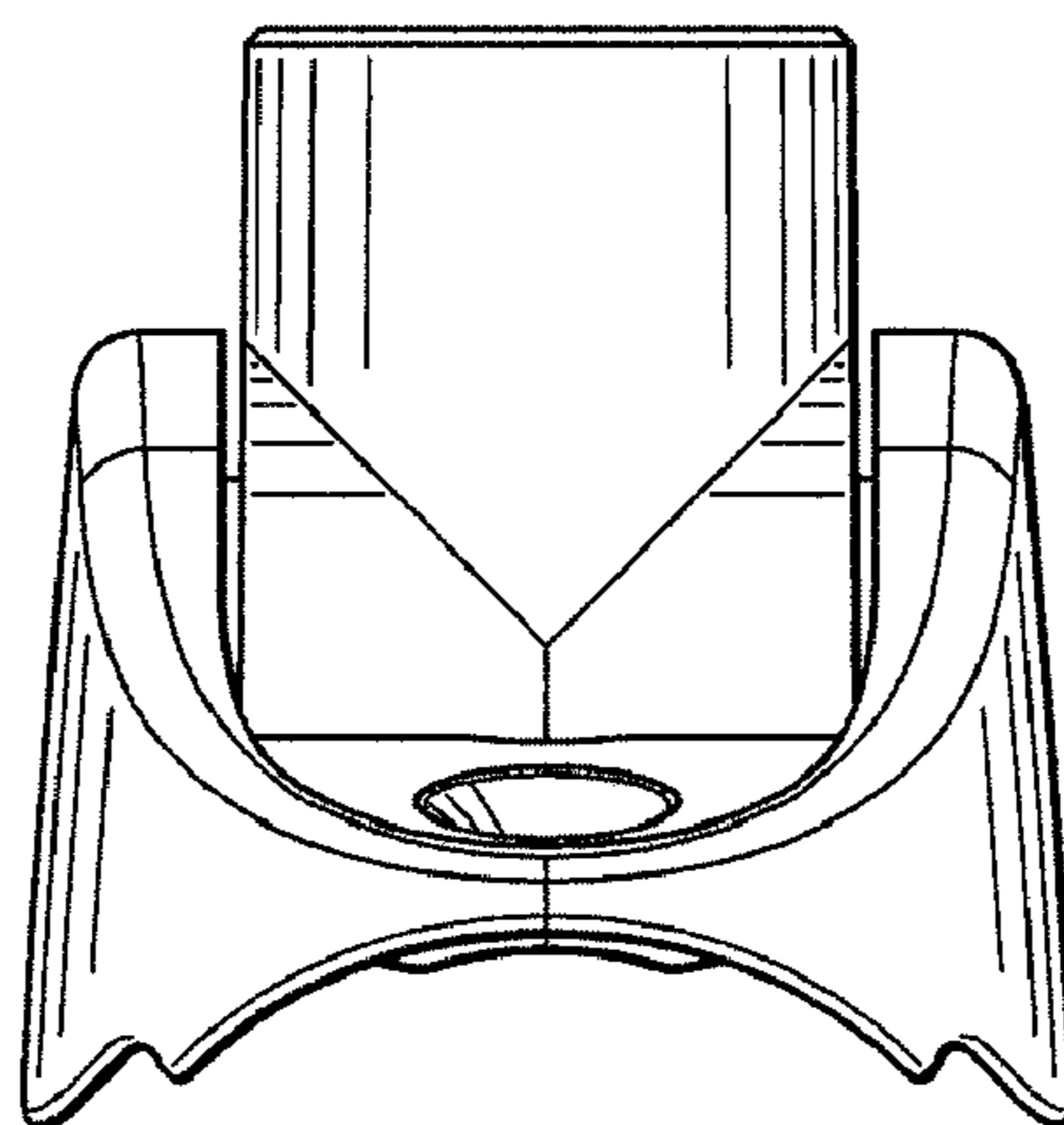
**Fig. 2**



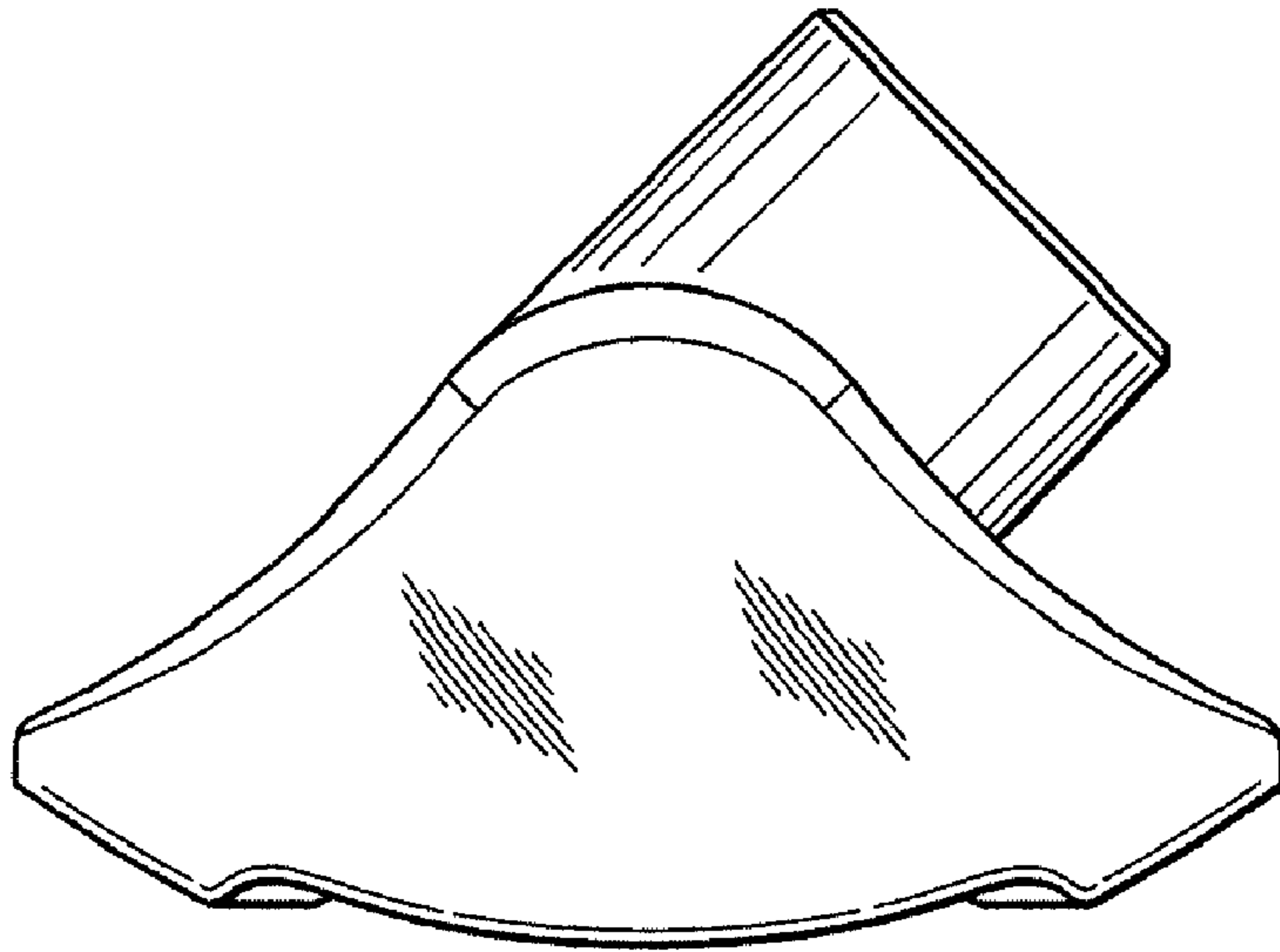
**Fig. 3**



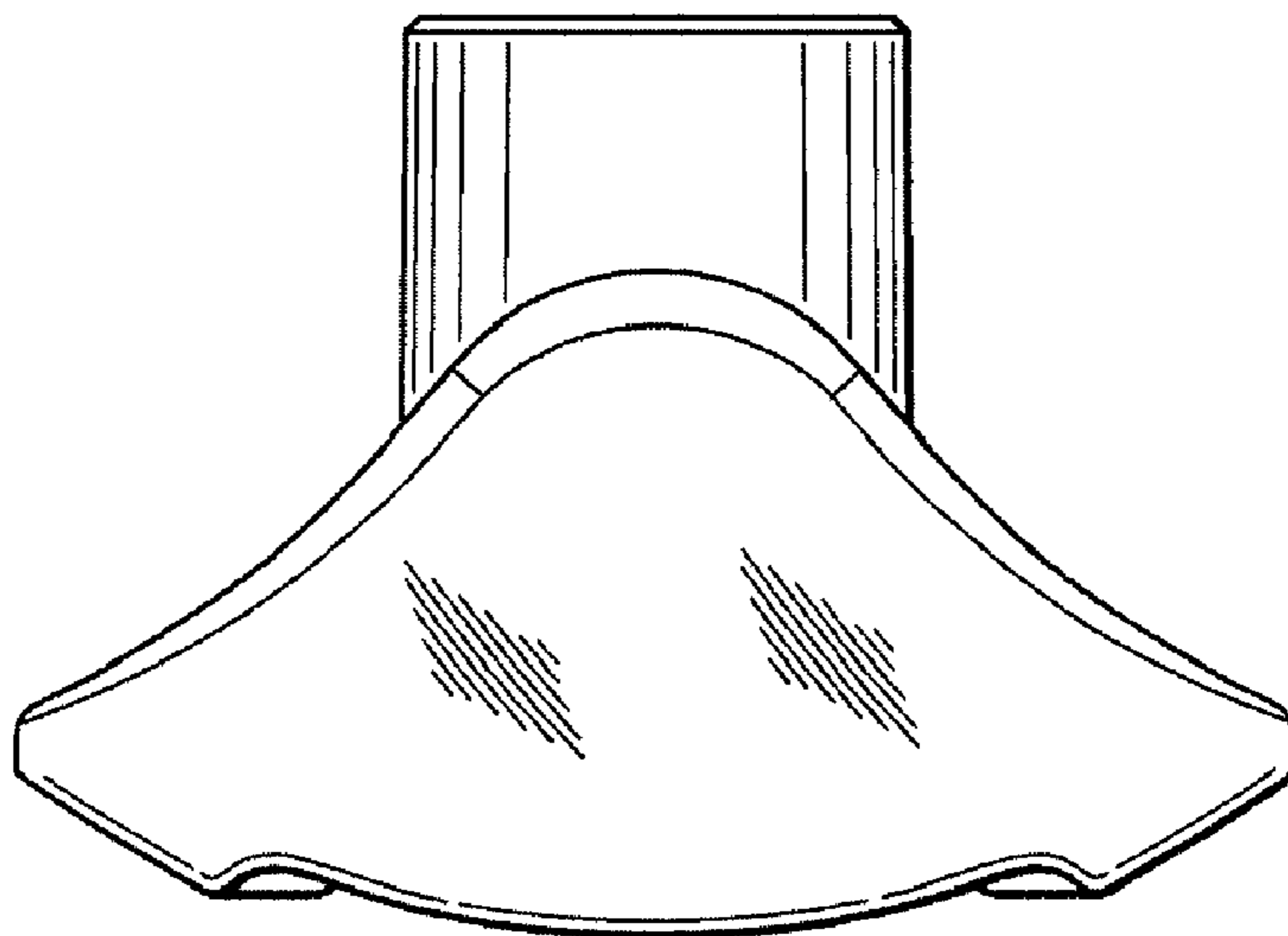
**Fig. 4**



**Fig. 5**



**Fig. 6**



**Fig. 7**