



US00D566632S

(12) **United States Design Patent**
Hutchins

(10) **Patent No.:** **US D566,632 S**

(45) **Date of Patent:** **** Apr. 15, 2008**

(54) **PORTION OF A VEHICLE REAR BUMPER**

(76) Inventor: **Michael Hutchins**, 7430 Cherry Valley Ave. SE., Caledonia, MI (US) 49316

(**) Term: **14 Years**

(21) Appl. No.: **29/248,966**

(22) Filed: **Sep. 12, 2006**

(51) **LOC (8) Cl.** **12-16**

(52) **U.S. Cl.** **D12/169**

(58) **Field of Classification Search** D12/90-92,
D12/86, 169, 196, 163; 296/193.1, 181.1;
293/102, 113, 115, 117, 120

See application file for complete search history.

(56) **References Cited**

U.S. PATENT DOCUMENTS

1,670,737 A	5/1928	Muser
2,624,607 A	1/1953	Wiegand
2,758,866 A	8/1956	Dollar
2,793,900 A	5/1957	Marshall
3,388,523 A	6/1968	Evans
3,517,473 A	6/1970	Kistner et al.
3,778,093 A	12/1973	Renner
3,842,565 A	10/1974	Brown et al.
3,848,916 A	11/1974	Hulten
D251,509 S	4/1979	Wenrick
4,274,668 A	6/1981	Kluss et al.
4,325,574 A	4/1982	Umemoto
4,364,591 A	12/1982	Bien
D292,198 S	10/1987	Kawaoka
4,997,229 A	3/1991	Swanson
5,183,303 A	2/1993	Zoller
D382,237 S	8/1997	Lund et al.
D417,641 S	12/1999	Saleen
6,010,169 A	1/2000	Cox et al.
D423,999 S	5/2000	Fink
D427,955 S	7/2000	Sacco et al.

D439,553 S	3/2001	Sacco et al.	
D446,485 S	8/2001	Shin	
D447,452 S	9/2001	Im	
D447,453 S	9/2001	Kim	
D447,454 S	9/2001	Kim	
D448,330 S	9/2001	Tampi	
6,290,271 B1	9/2001	Geisler	
6,319,438 B1	11/2001	Smith et al.	
D462,308 S	9/2002	Yokomaku	
D466,060 S	11/2002	Snook et al.	
6,602,591 B1	8/2003	Smith	
6,652,011 B1 *	11/2003	Khan D12/169
6,818,305 B2	11/2004	Murar et al.	
7,005,103 B2	2/2006	Smith et al.	
D543,914 S *	6/2007	Lai D12/181

* cited by examiner

Primary Examiner—Melody N. Brown

(74) *Attorney, Agent, or Firm*—Paparella & Associates;
Joseph A. Paparella

(57) **CLAIM**

The ornamental design for a portion of a vehicle rear bumper, as shown and described.

DESCRIPTION

FIG. 1 is a front perspective view of a portion of a vehicle rear bumper showing my new design, the portion of the vehicle shown in broken lines are for illustrative purposes only and form no part of the claimed design;

FIG. 2 is another front perspective view thereof;

FIG. 3 is a top plan view thereof;

FIG. 4 is a front elevational view thereof;

FIG. 5 is a side elevational view thereof;

FIG. 6 is a bottom plan view thereof, and,

FIG. 7 is a rear elevational view thereof.

1 Claim, 5 Drawing Sheets

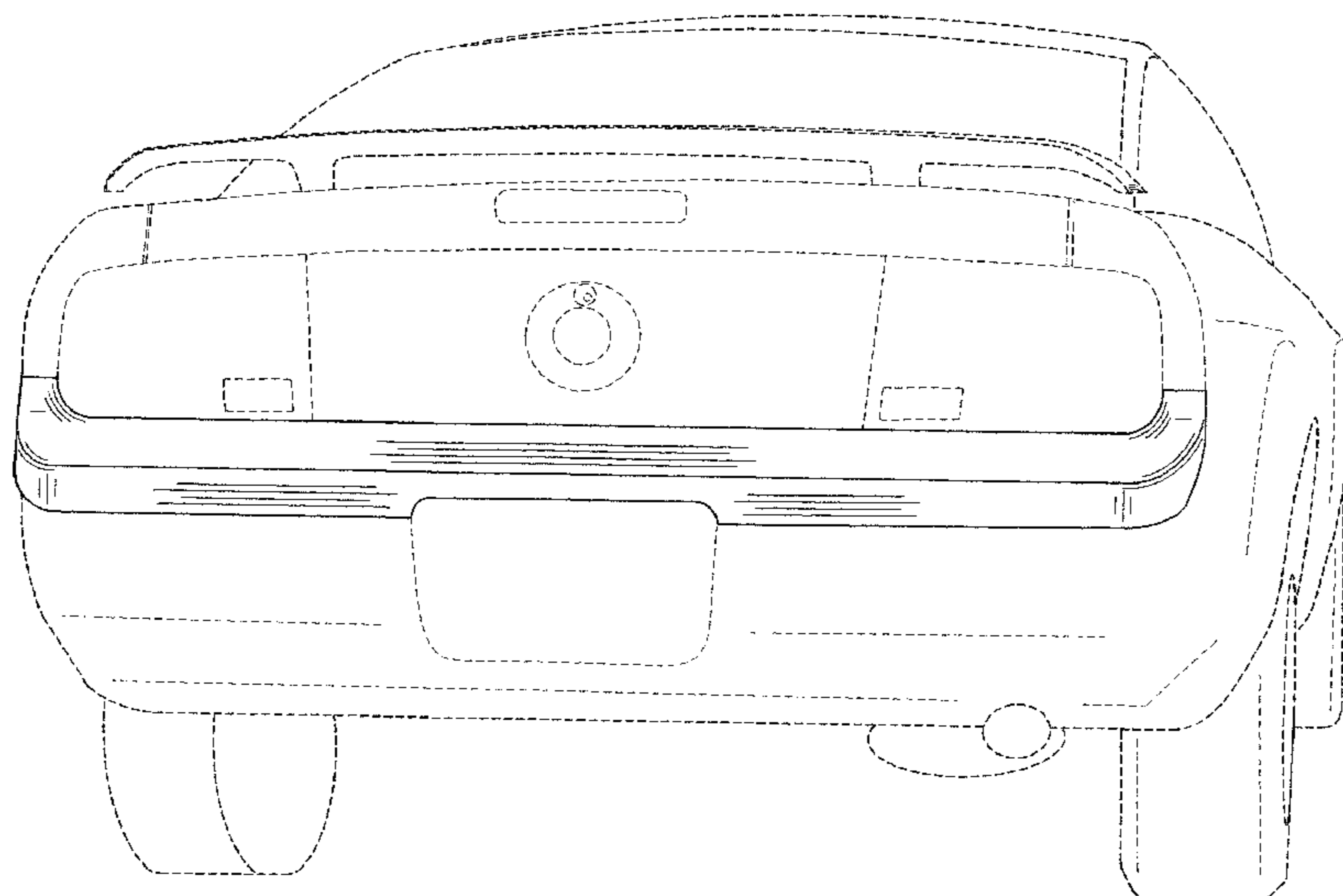

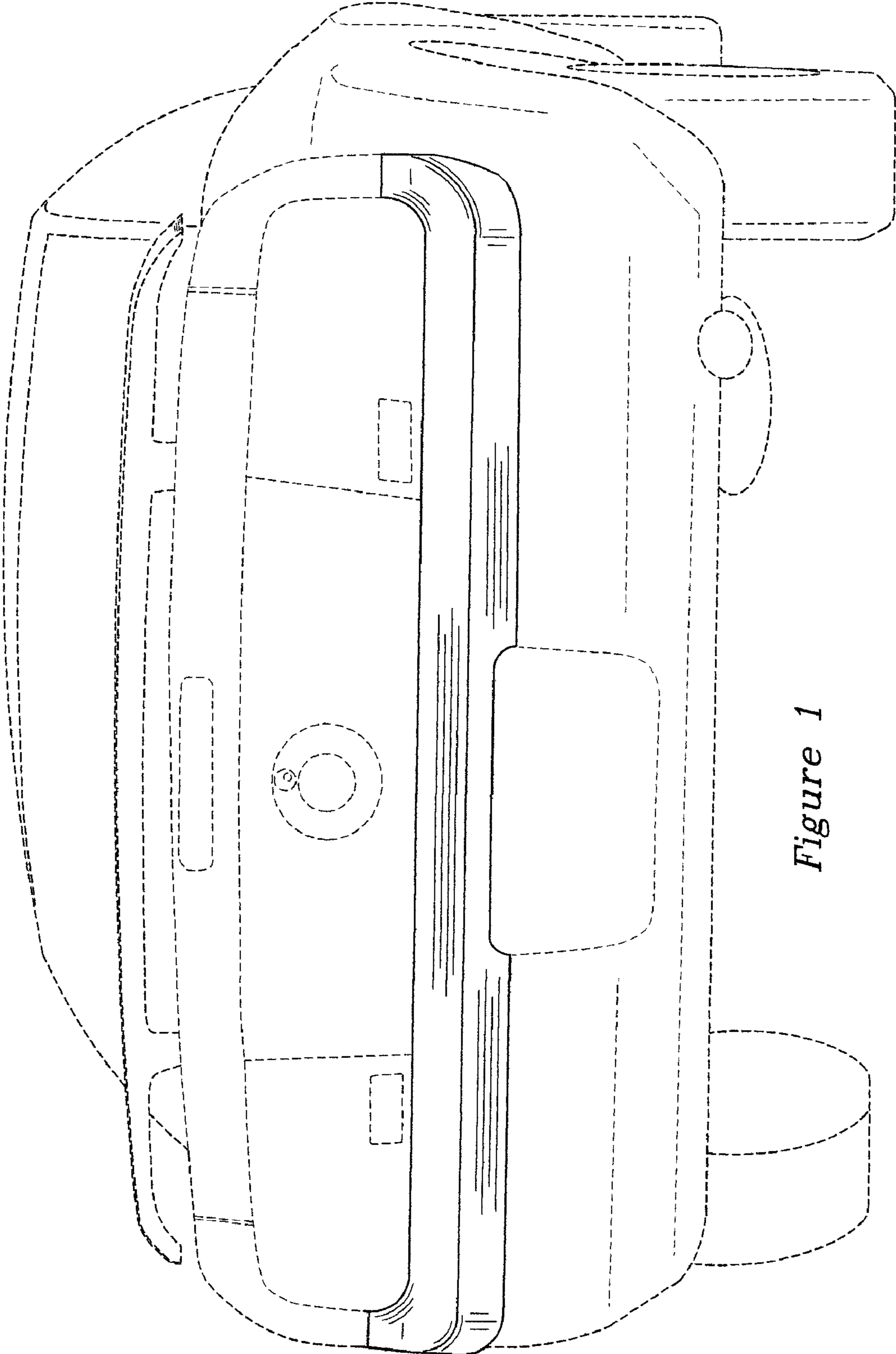

Figure 1

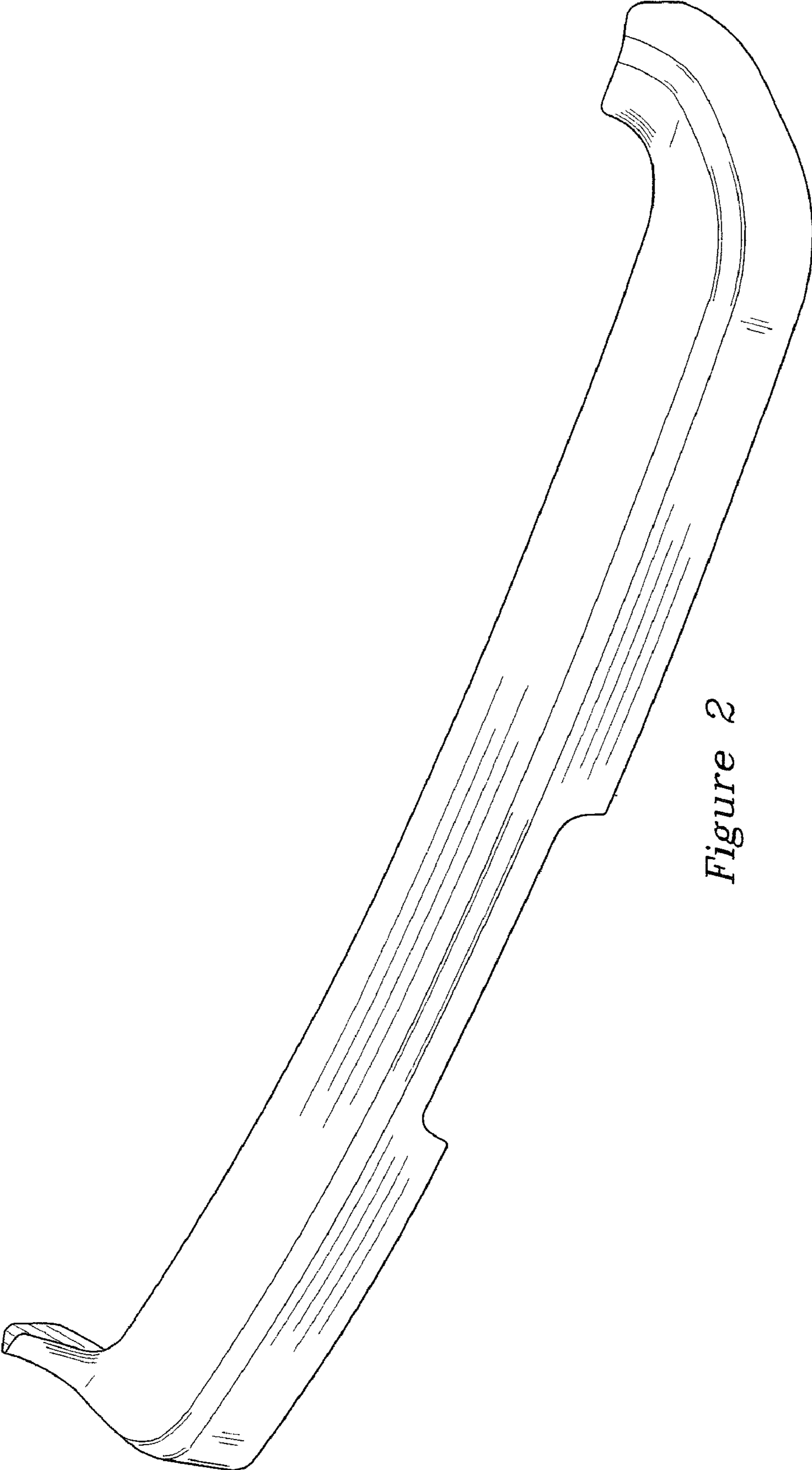

Figure 2

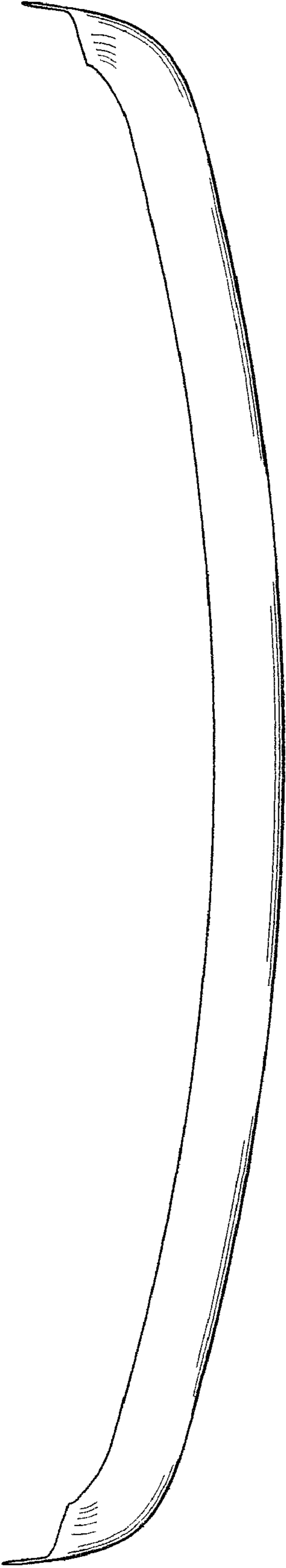

Figure 3

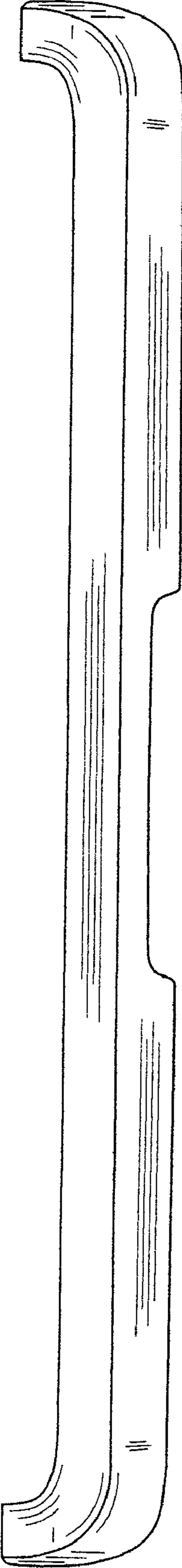

Figure 4

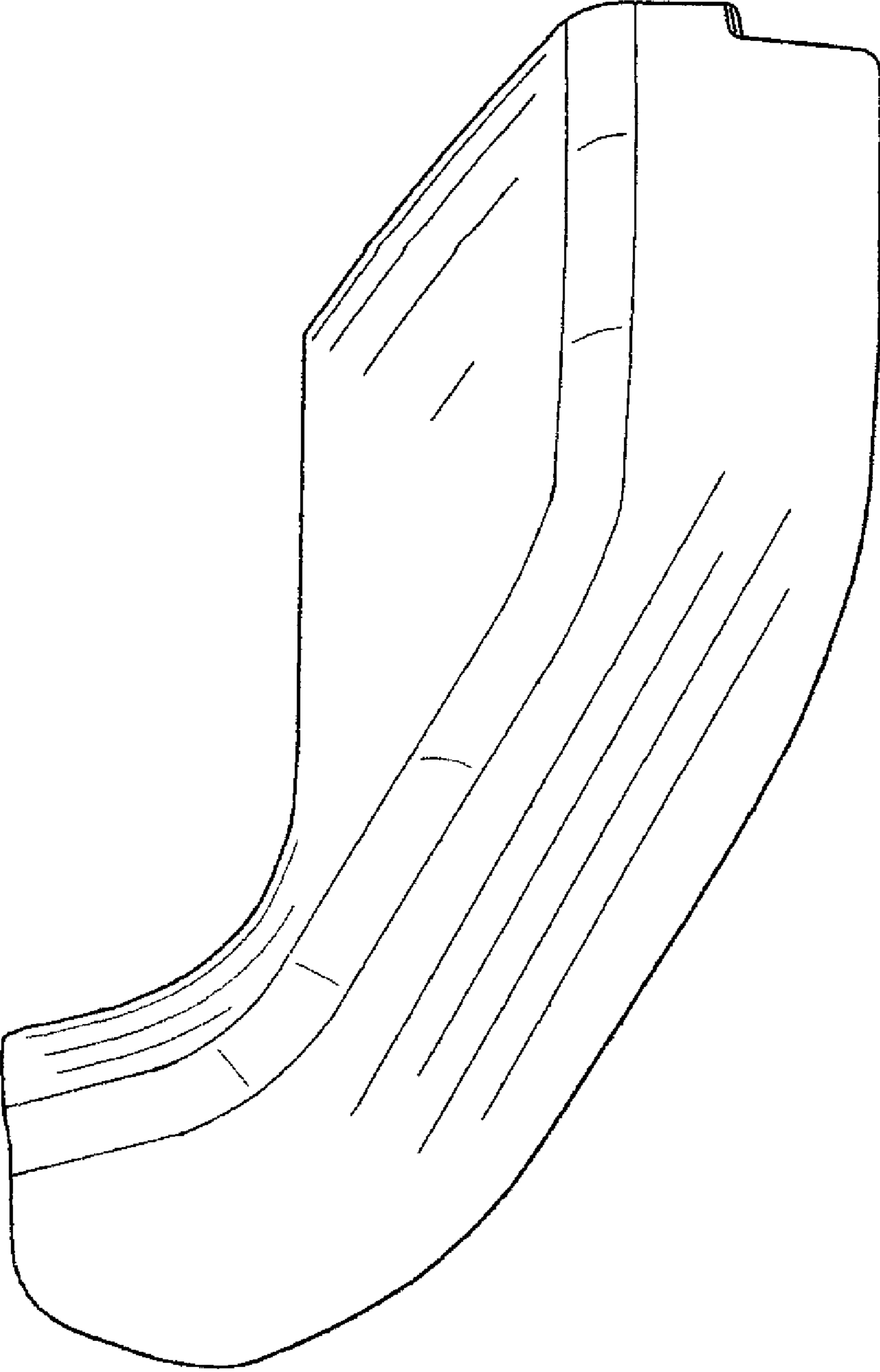

Figure 5

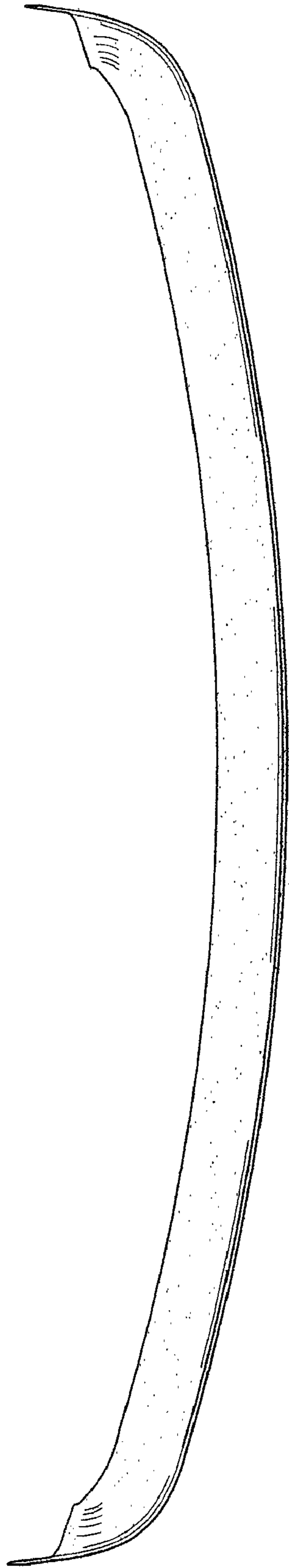

Figure 6

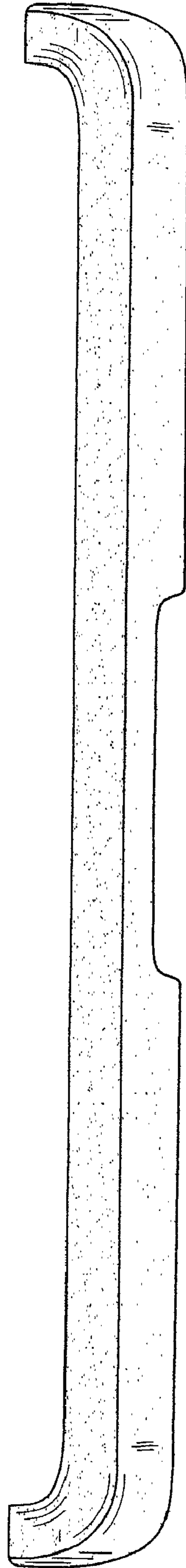

Figure 7