



US00D566556S

(12) **United States Design Patent**
Baker et al.

(10) **Patent No.:** **US D566,556 S**
(45) **Date of Patent:** **** Apr. 15, 2008**

(54) **SEPARATOR PAD**

(75) Inventors: **Paul W. Baker**, Cambridge, OH (US);
Thomas M. Quinn, New Concord, OH
(US); **Terence W. Staed**, St. Louis, MO
(US); **Richard H. Lee**, St. Louis, MO
(US)

(73) Assignee: **The Fabri-Form Company**, New
Concord, OH (US)

(**) Term: **14 Years**

(21) Appl. No.: **29/289,168**

(22) Filed: **Jul. 10, 2007**

(51) **LOC (8) Cl.** **09-07**

(52) **U.S. Cl.** **D9/456**

(58) **Field of Classification Search** D9/341,
D9/346, 414, 420, 423, 424, 433, 434, 455,
D9/456; D3/284, 285, 295, 303, 318, 319,
D3/321, 324; D6/511; D15/89; D19/77;
15/215; 206/386, 521.1; D34/38; 220/250;
190/17, 35

See application file for complete search history.

(56) **References Cited**

U.S. PATENT DOCUMENTS

2,701,890 A * 2/1955 Moor, Jr. 15/215
D199,765 S * 12/1964 Weiss D9/456
D201,925 S * 8/1965 Weiss D9/456
D205,198 S * 7/1966 Loney D9/456
D209,479 S * 12/1967 Cutler D9/456

D241,777 S * 10/1976 Allman D15/89
D279,583 S * 7/1985 Hall D19/77
D311,339 S * 10/1990 Weed D9/456
5,205,410 A * 4/1993 Kuipers et al. 206/386
D356,734 S * 3/1995 Orec D9/456
D395,166 S * 6/1998 Grey D3/319
D463,667 S * 10/2002 Hwang D3/323
D502,031 S * 2/2005 Cassidy et al. D6/511

* cited by examiner

Primary Examiner—T. Chase Nelson

Assistant Examiner—Barbara B Lohr

(74) *Attorney, Agent, or Firm*—Renner, Kenner, Greive,
Bobak, Taylor & Weber

(57) **CLAIM**

The ornamental design for a separator pad, as shown and
described.

DESCRIPTION

FIG. 1 is a top, front, left side perspective view of a separator
pad showing our new design;

FIG. 2 is a bottom, rear, right side perspective view thereof;

FIG. 3 is a top plan view thereof;

FIG. 4 is a bottom plan view thereof;

FIG. 5 is a right side elevational view thereof;

FIG. 6 is a left side elevational view thereof; and,

FIG. 7 is a front elevational view thereof, the rear elevational
view being a mirror image of FIG. 7.

1 Claim, 5 Drawing Sheets

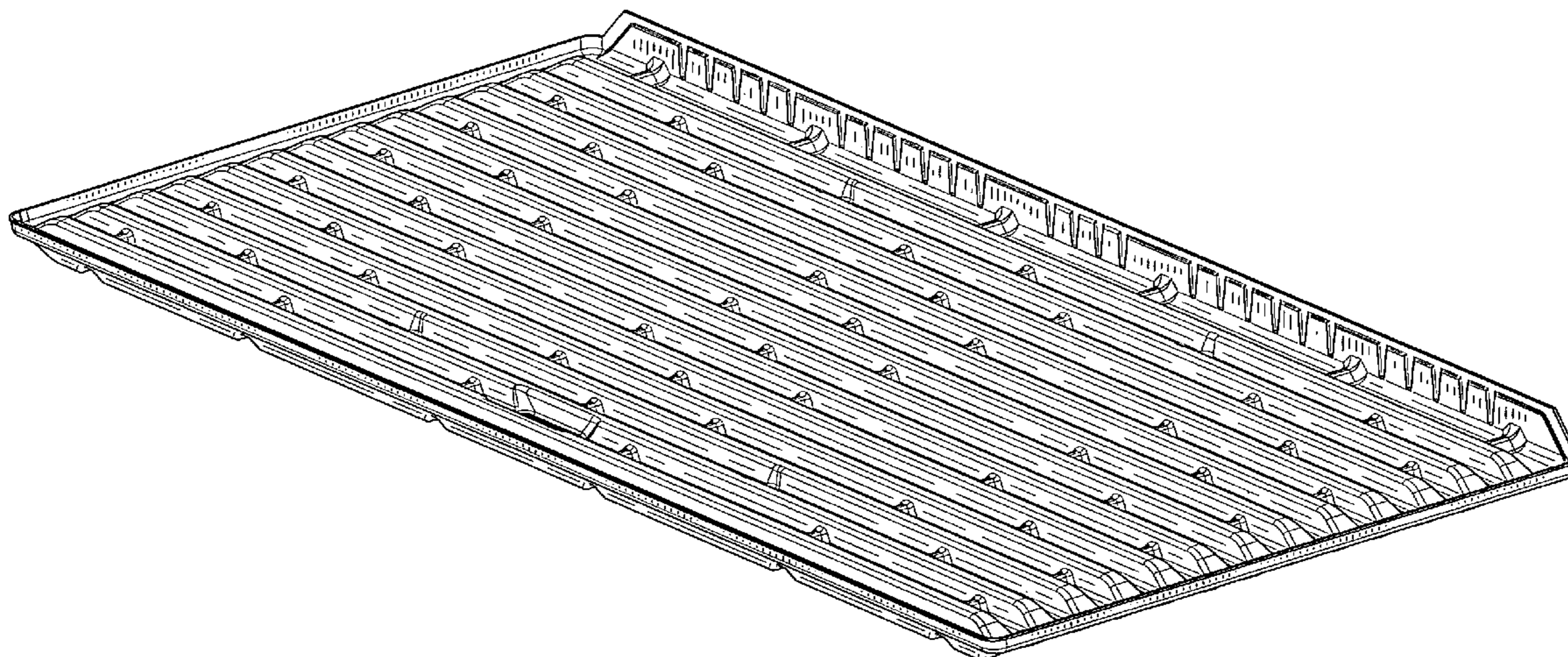

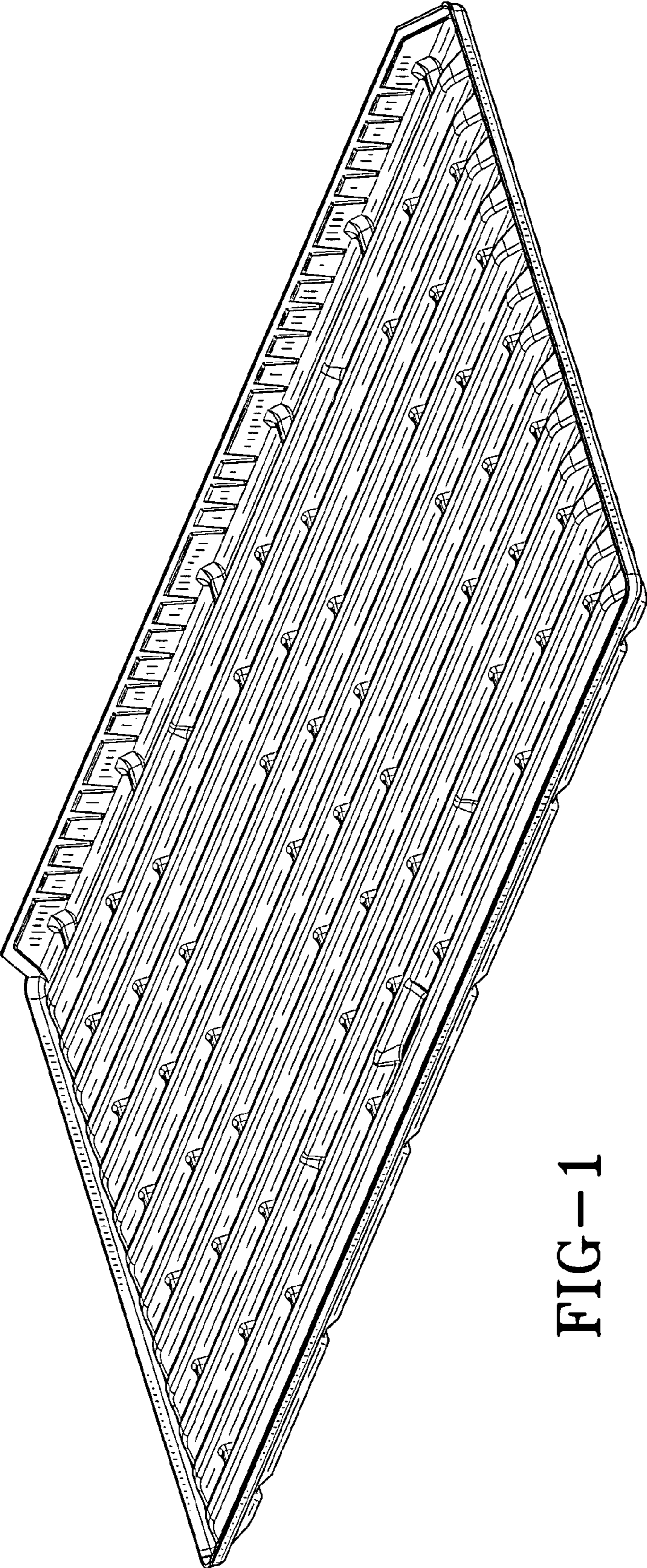

FIG-1

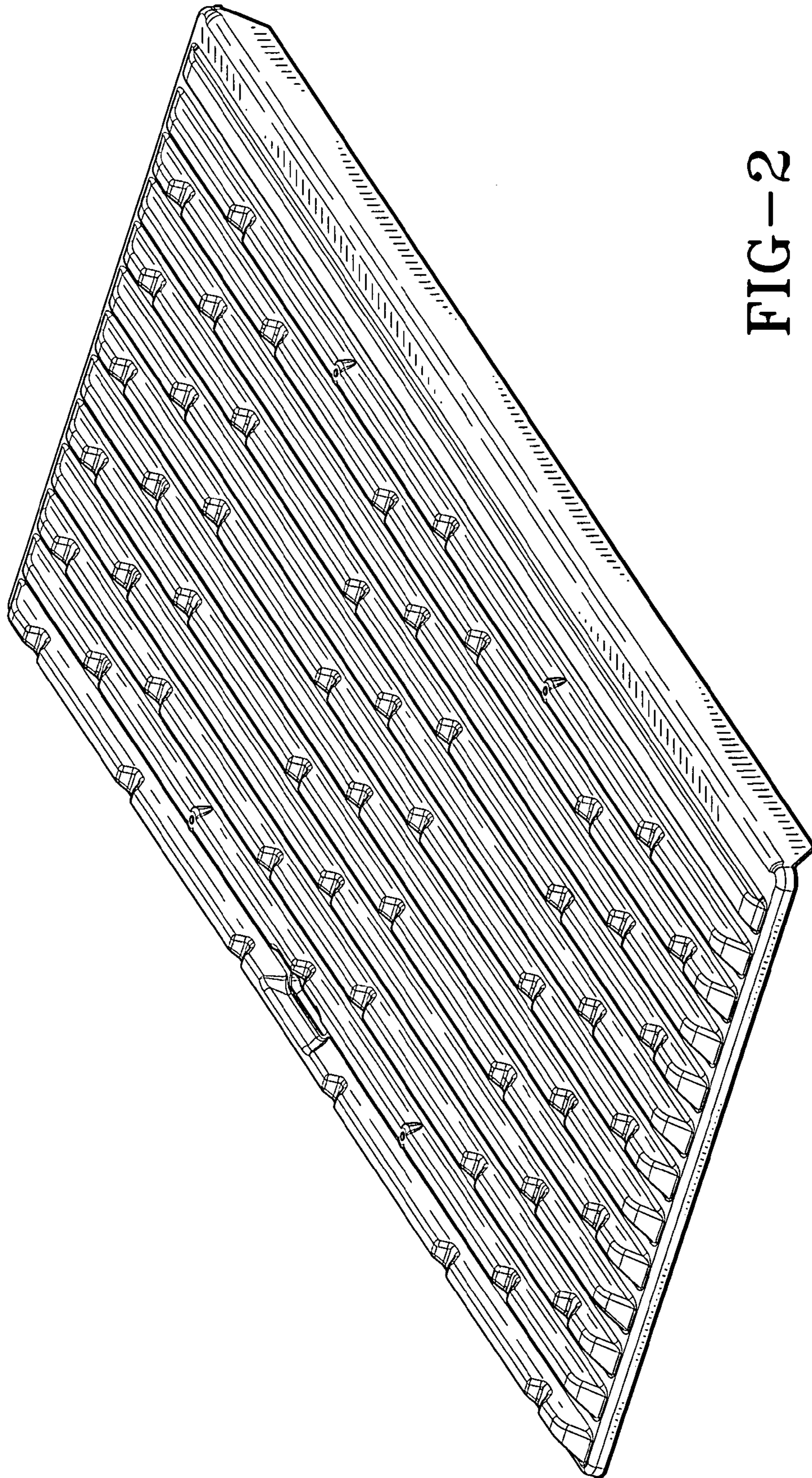

FIG-2

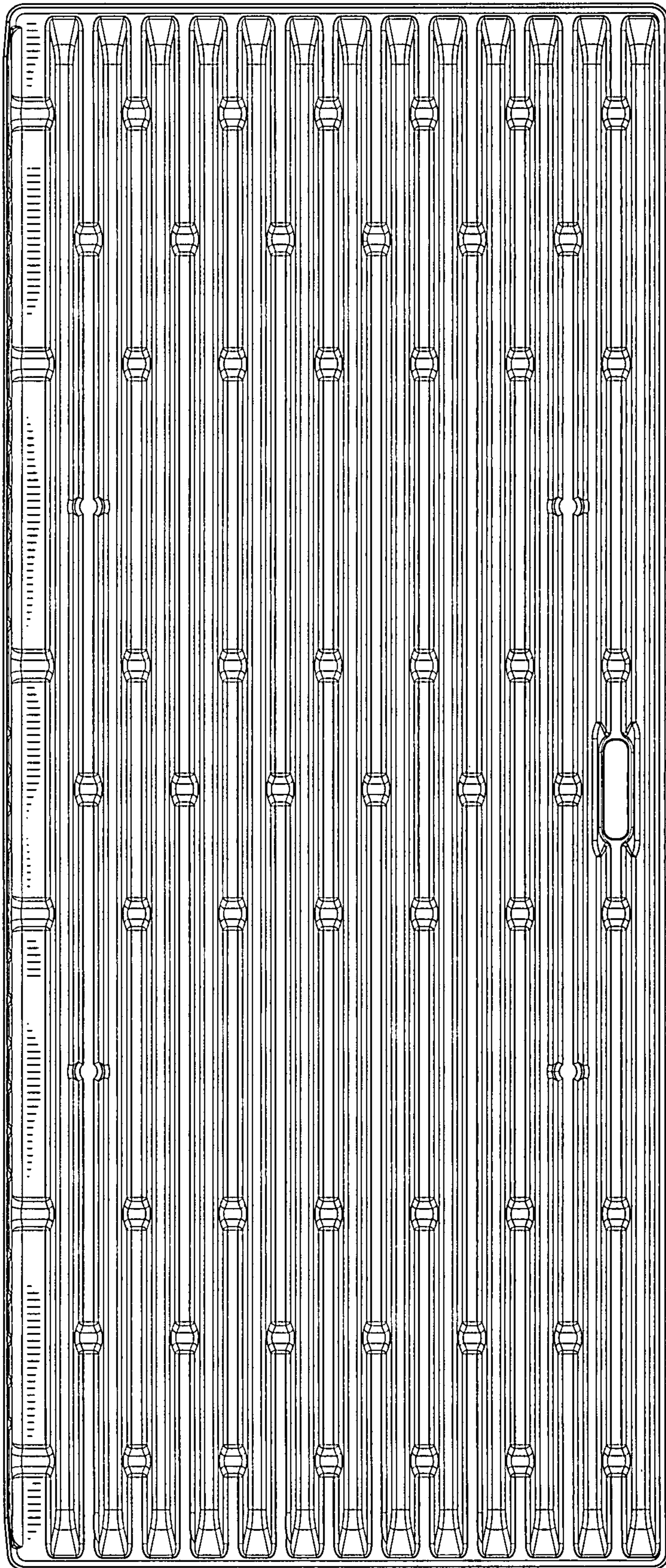

FIG-3

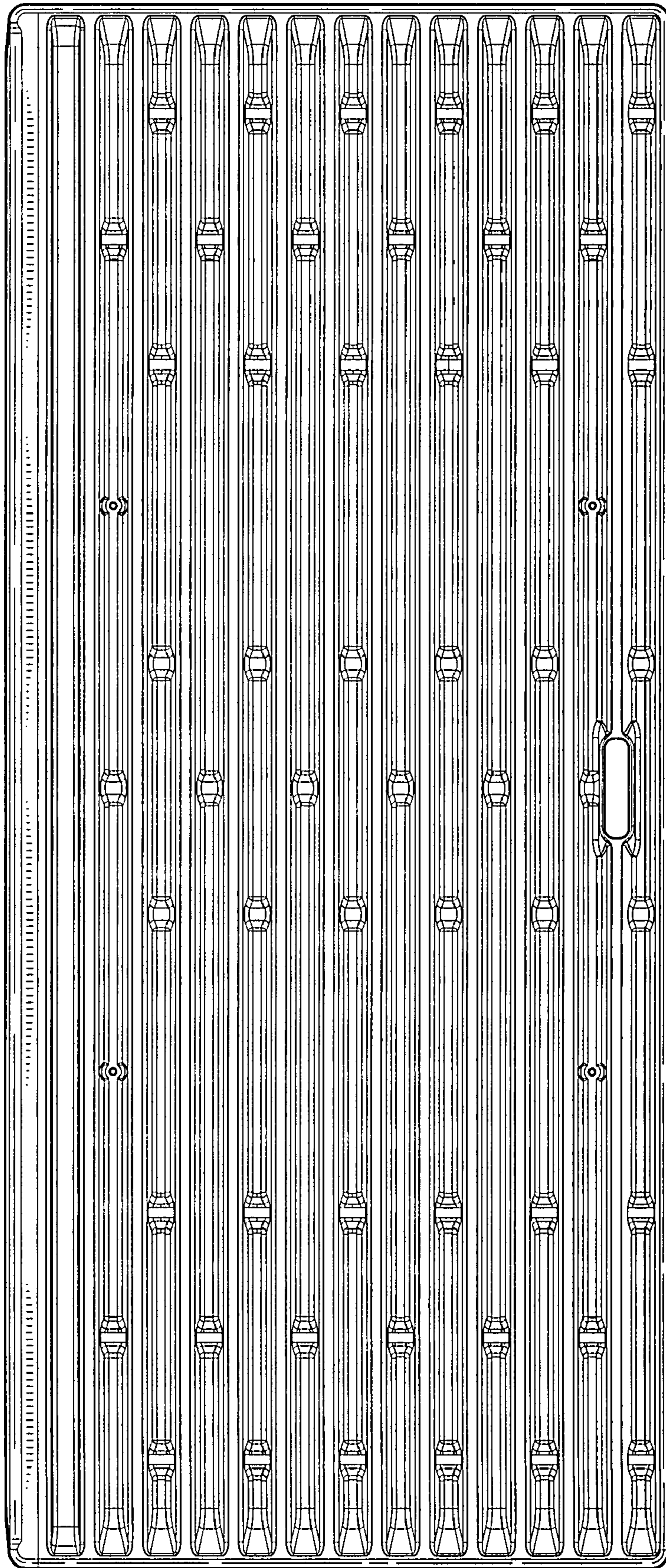

FIG-4

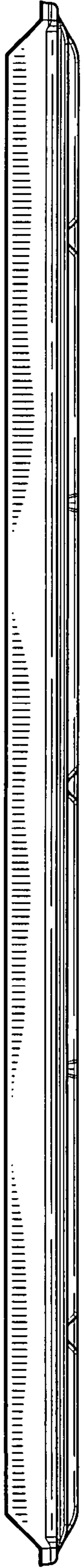

FIG-5



FIG-6

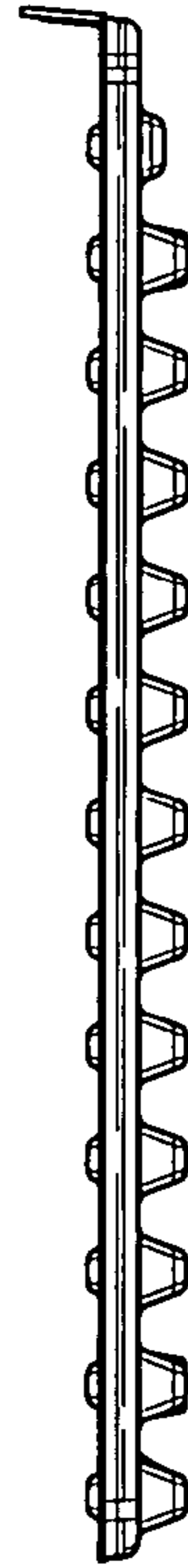

FIG-7