

US00D566032S

(12) **United States Design Patent**  
**Berthou et al.**

(10) **Patent No.:** **US D566,032 S**

(45) **Date of Patent:** **\*\* Apr. 8, 2008**

(54) **PILOT MULTIPURPOSE CURSOR CONTROL  
UNIT FOR VIBRATIONS ENVIRONMENT**

D346,146 S \* 4/1994 Halwes ..... D12/345  
5,427,336 A \* 6/1995 Haggerty et al. .... 244/229  
6,224,014 B1 \* 5/2001 Dussac ..... 244/17.27  
6,467,723 B1 \* 10/2002 Rossetti et al. .... 244/17.11

(75) Inventors: **Nicolas Berthou**, Cholet (FR); **Malo Guegan**, Vineuil (FR); **Jérôme Dufal**, La Chaussee Saint Victor (FR)

\* cited by examiner

(73) Assignees: **Thales Avionics SA**, Massy (FR); **Airbus France**, Toulouse (FR)

*Primary Examiner*—Ian Simmons

*Assistant Examiner*—Maurice Stevens

(74) *Attorney, Agent, or Firm*—Oblon, Spivak, McClelland, Maier & Neustadt, P.C.

(\*\*) Term: **14 Years**

(21) Appl. No.: **29/211,441**

(57) **CLAIM**

(22) Filed: **Aug. 17, 2004**

The ornamental design for a pilot multipurpose cursor control unit for vibrations environment, as shown and described.

(30) **Foreign Application Priority Data**

Feb. 27, 2007 (FR) ..... 04 1000

**DESCRIPTION**

(51) **LOC (8) Cl.** ..... **12-07**

FIG. 1 is a front, left and top perspective view of a pilot multipurpose cursor control unit for vibrations environment showing our new design;

(52) **U.S. Cl.** ..... **D12/345**

(58) **Field of Classification Search** ..... D12/345;  
D9/430; D15/147; 244/17.27

FIG. 2 is a partial back, left and top perspective view thereof;

See application file for complete search history.

FIG. 3 is a back, left and top perspective view thereof;

(56) **References Cited**

FIG. 4 is a top view thereof; and,

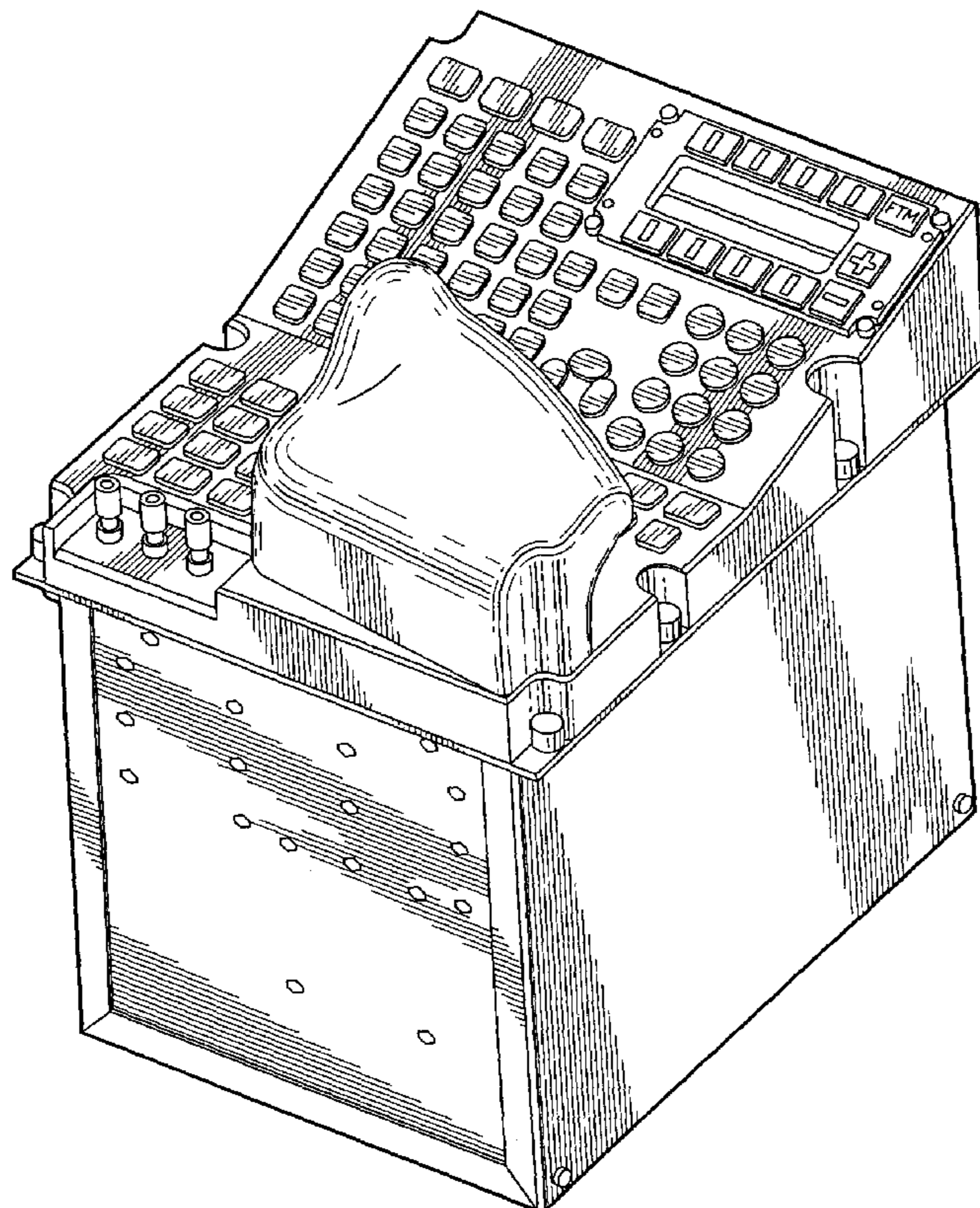
**U.S. PATENT DOCUMENTS**

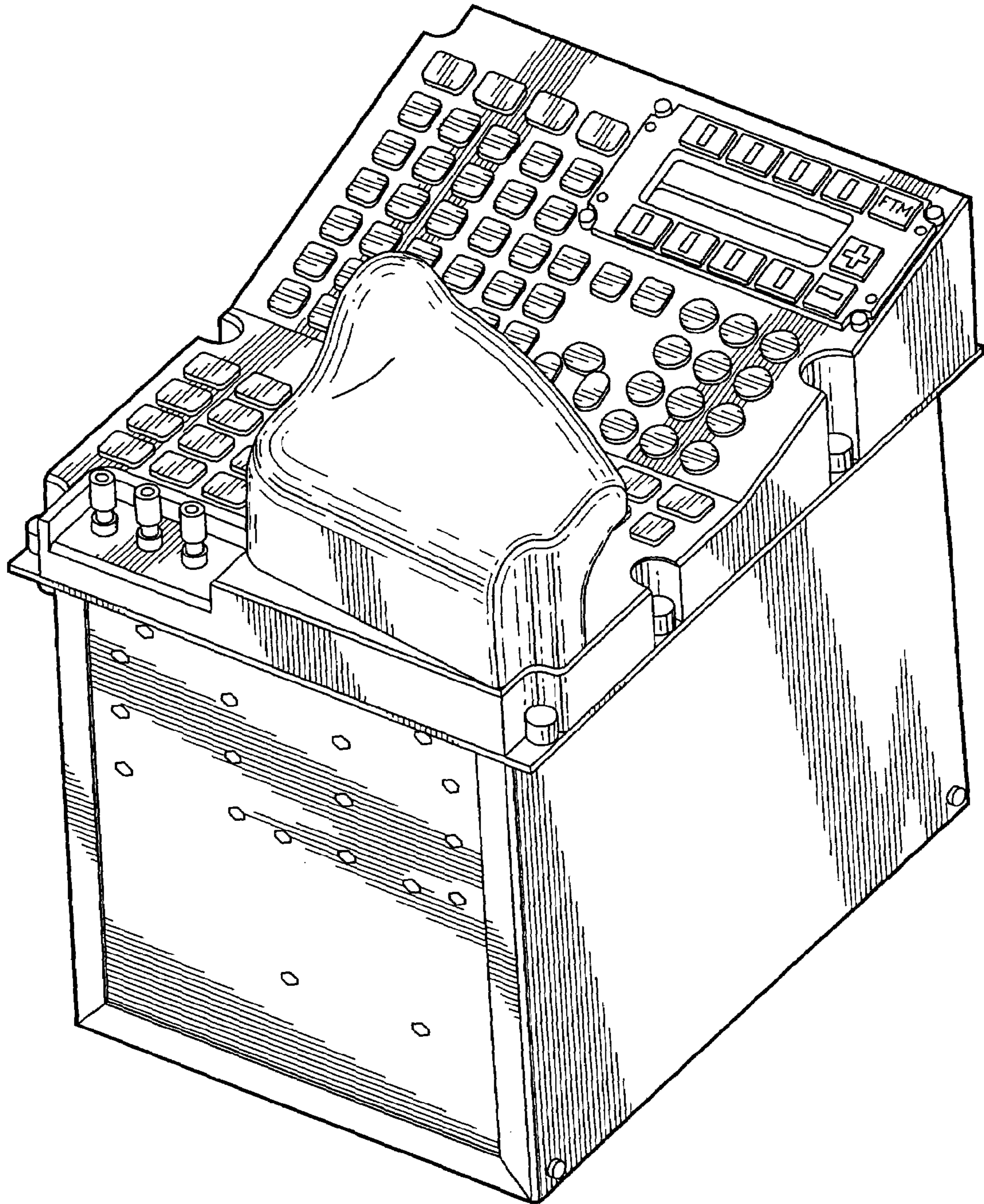
FIG. 5 is a back, right and top perspective view thereof.

4,892,273 A \* 1/1990 Fedor ..... 244/173.2

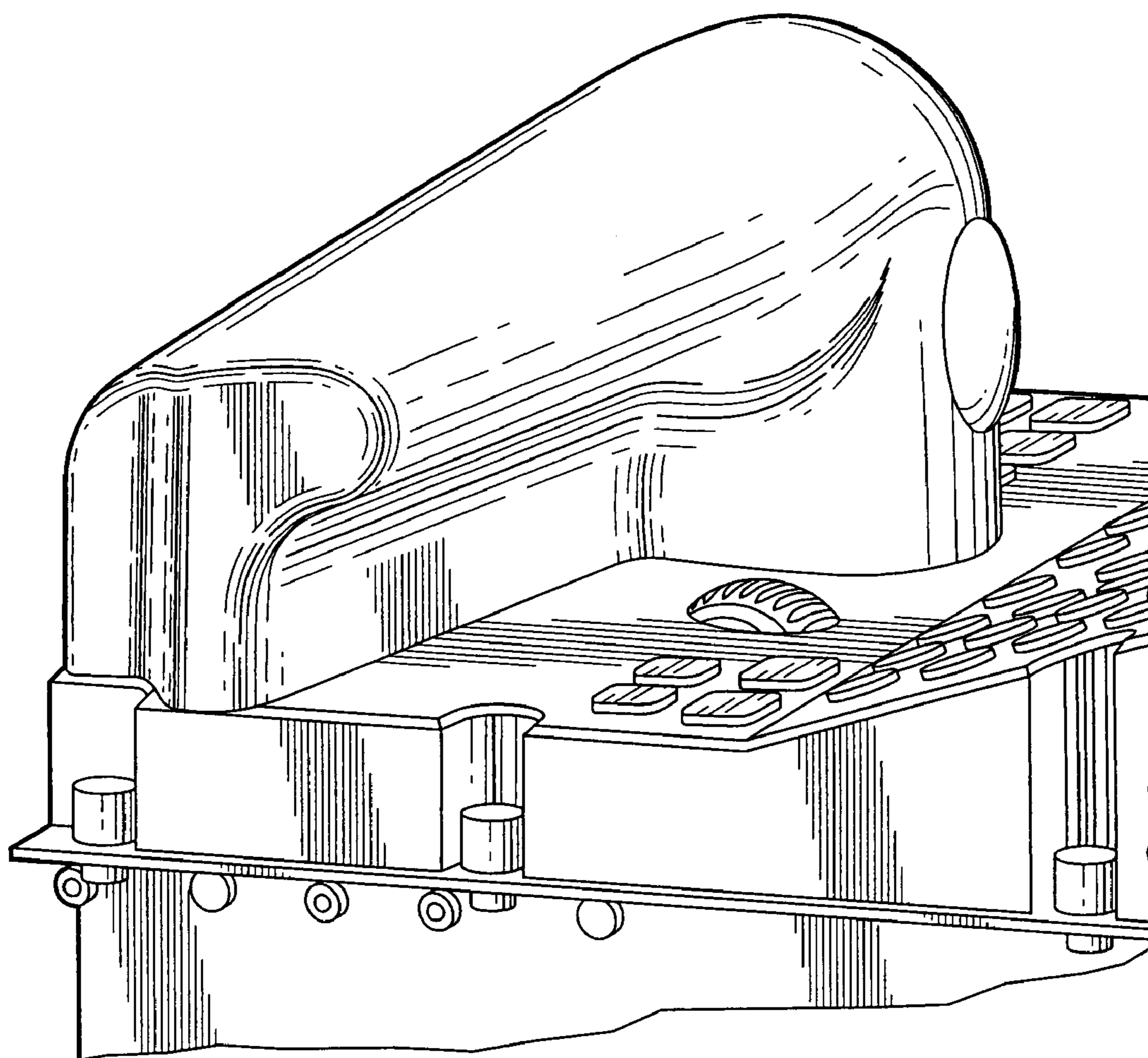
D338,186 S \* 8/1993 Halwes ..... D12/345

**1 Claim, 5 Drawing Sheets**

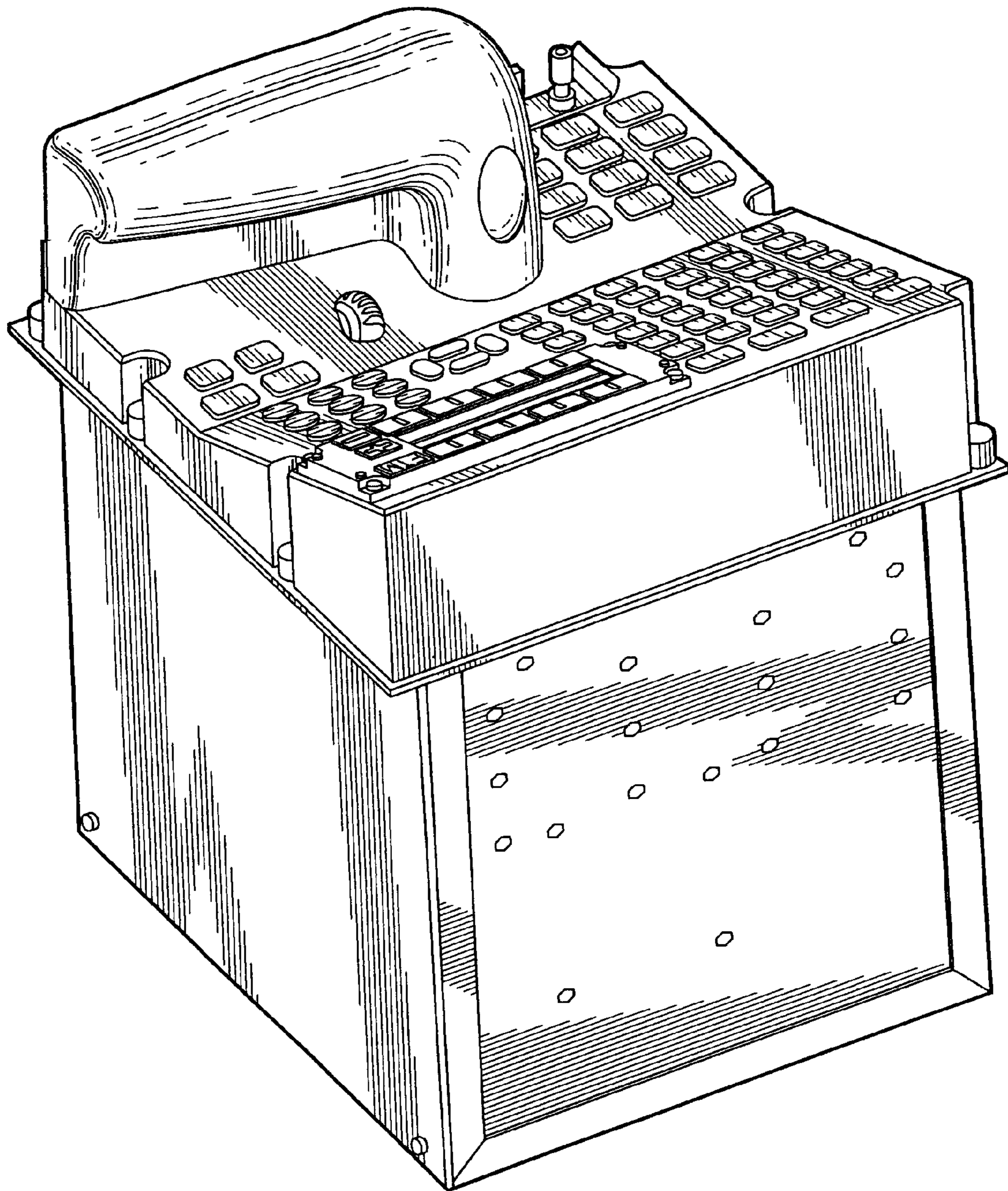




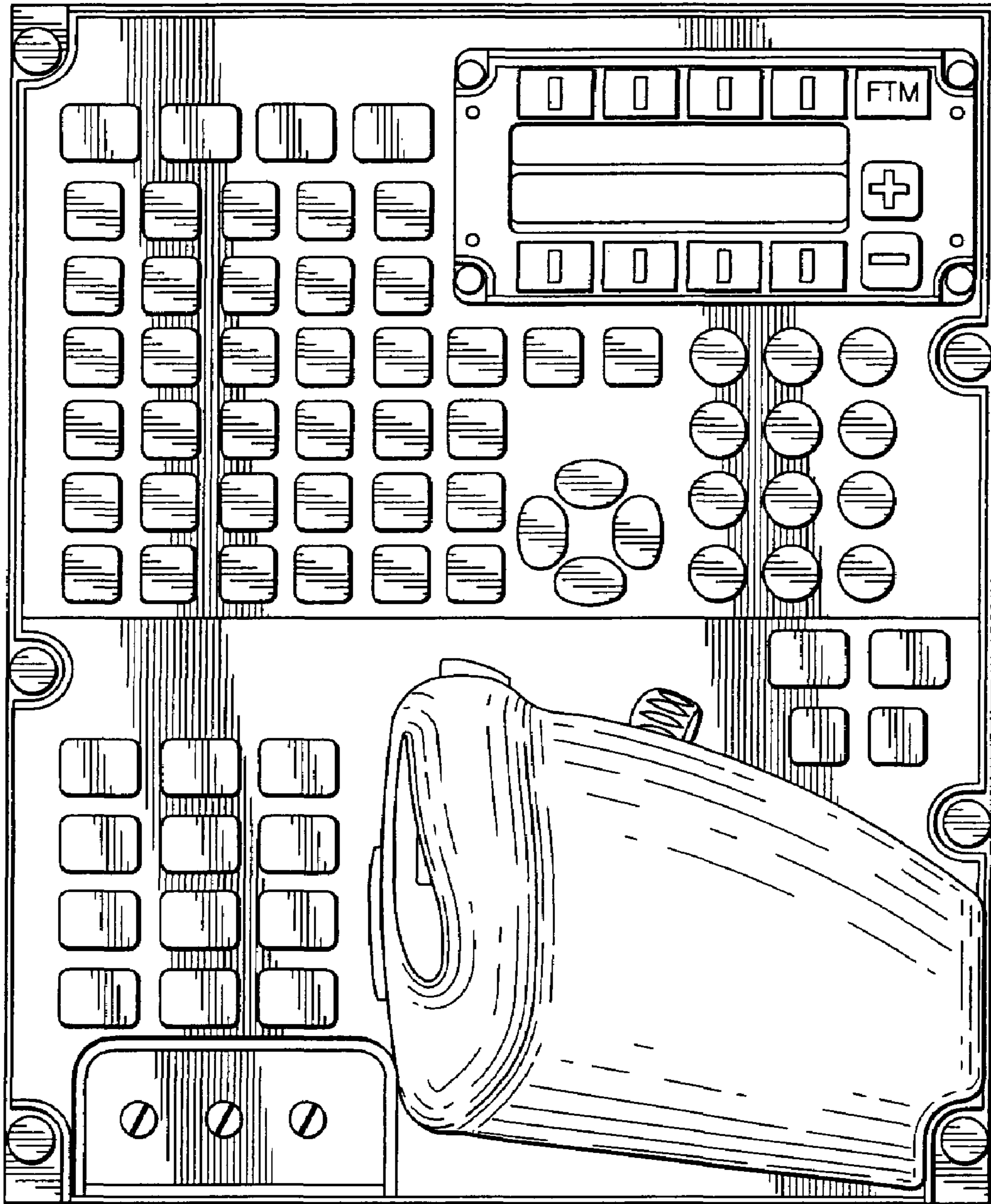
*Fig. 1*



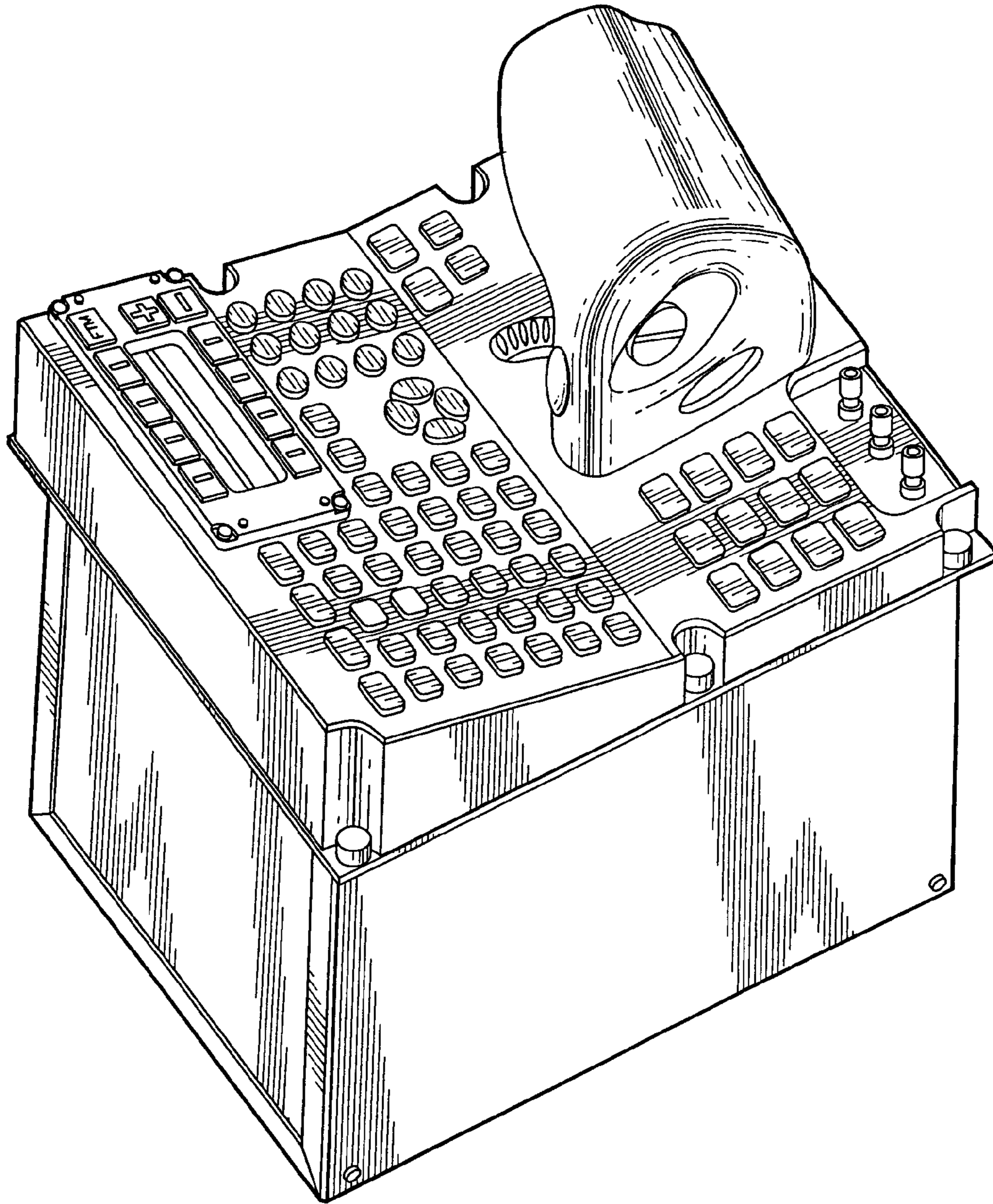
*Fig. 2*



*Fig. 3*



*Fig. 4*



*Fig. 5*