



US00D565825S

(12) **United States Design Patent**  
**Shibata et al.**

(10) **Patent No.:** **US D565,825 S**

(45) **Date of Patent:** **\*\* Apr. 1, 2008**

(54) **FORKLIFT TRUCK**

(75) Inventors: **Naoki Shibata**, Aichi-Ken (JP);  
**Kiyomitsu Ogawa**, Kanagawa-Ken (JP)

(73) Assignee: **Mitsubishi Heavy Industries, Ltd.**,  
Tokyo (JP)

(\*\*) Term: **14 Years**

(21) Appl. No.: **29/273,006**

(22) Filed: **Feb. 26, 2007**

(30) **Foreign Application Priority Data**

Aug. 29, 2006 (JP) ..... 2006-022854

(51) **LOC (8) Cl.** ..... **12-05**

(52) **U.S. Cl.** ..... **D34/34**

(58) **Field of Classification Search** ..... D34/34;  
414/529, 572, 607, 785; 180/89.12, 89.14,  
180/89.17; 187/222, 237

See application file for complete search history.

(56) **References Cited**

**U.S. PATENT DOCUMENTS**

5,184,699 A \* 2/1993 Aoki et al. .... 187/224  
D396,928 S \* 8/1998 Hahn et al. .... D34/34  
D412,385 S \* 7/1999 Murakami et al. .... D34/34  
D448,136 S \* 9/2001 Yurushi et al. .... D34/34

D468,885 S \* 1/2003 Salin et al. .... D34/34  
D470,990 S \* 2/2003 Han et al. .... D34/34  
D471,689 S \* 3/2003 Shibata et al. .... D34/34  
D526,460 S \* 8/2006 Goto et al. .... D34/34  
D538,004 S \* 3/2007 Kouyama et al. .... D34/34  
D544,174 S \* 6/2007 Quinlan et al. .... D34/34

\* cited by examiner

*Primary Examiner*—Cynthia E Ramirez

(74) *Attorney, Agent, or Firm*—Birch, Stewart, Kolasch &  
Birch, LLP

(57) **CLAIM**

The ornamental design for a forklift truck, as shown and described.

**DESCRIPTION**

FIG. 1 is a front view of the forklift truck showing our new design;

FIG. 2 is a rear view thereof;

FIG. 3 is a left side view thereof;

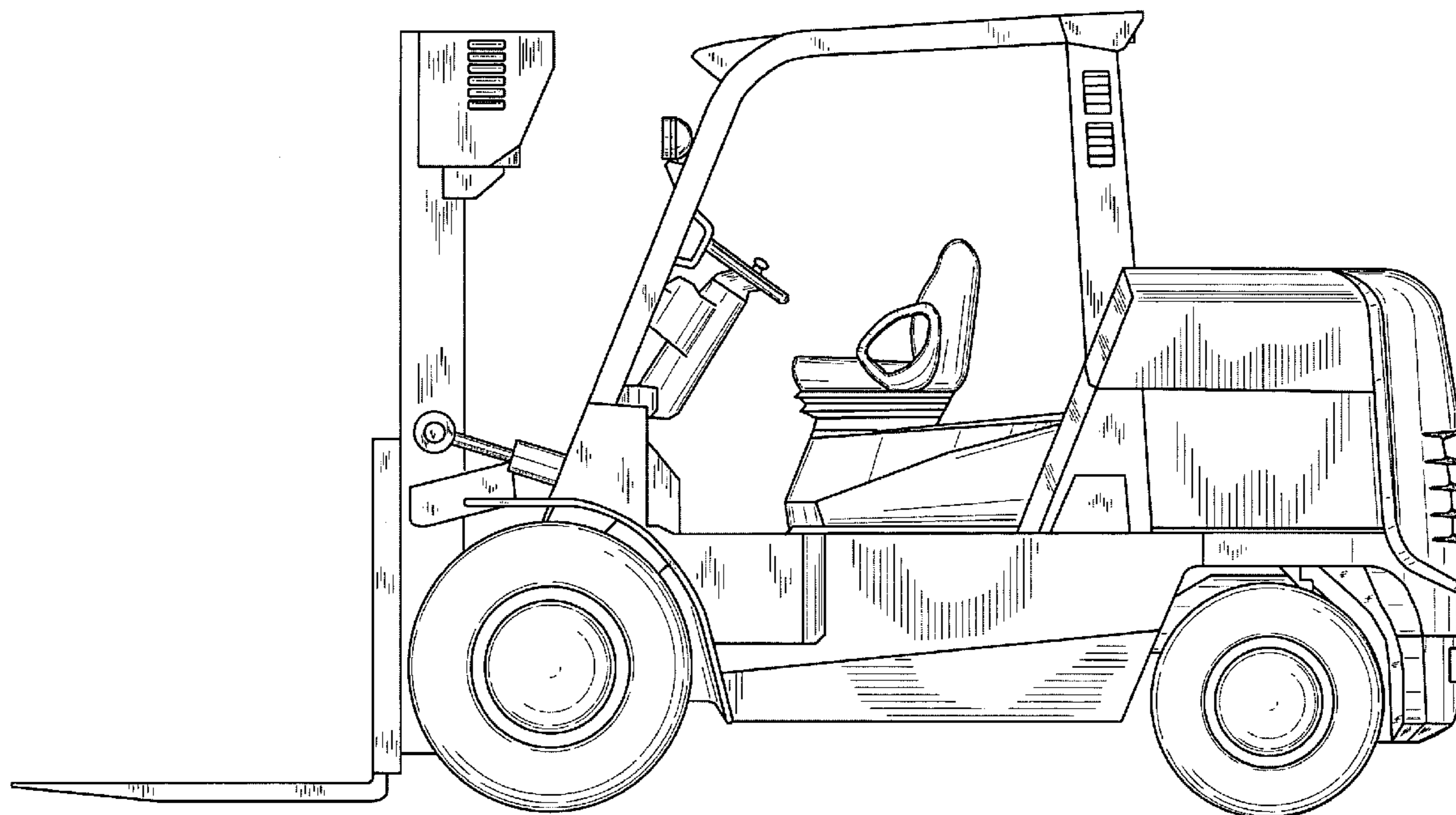
FIG. 4 is a right side view thereof;

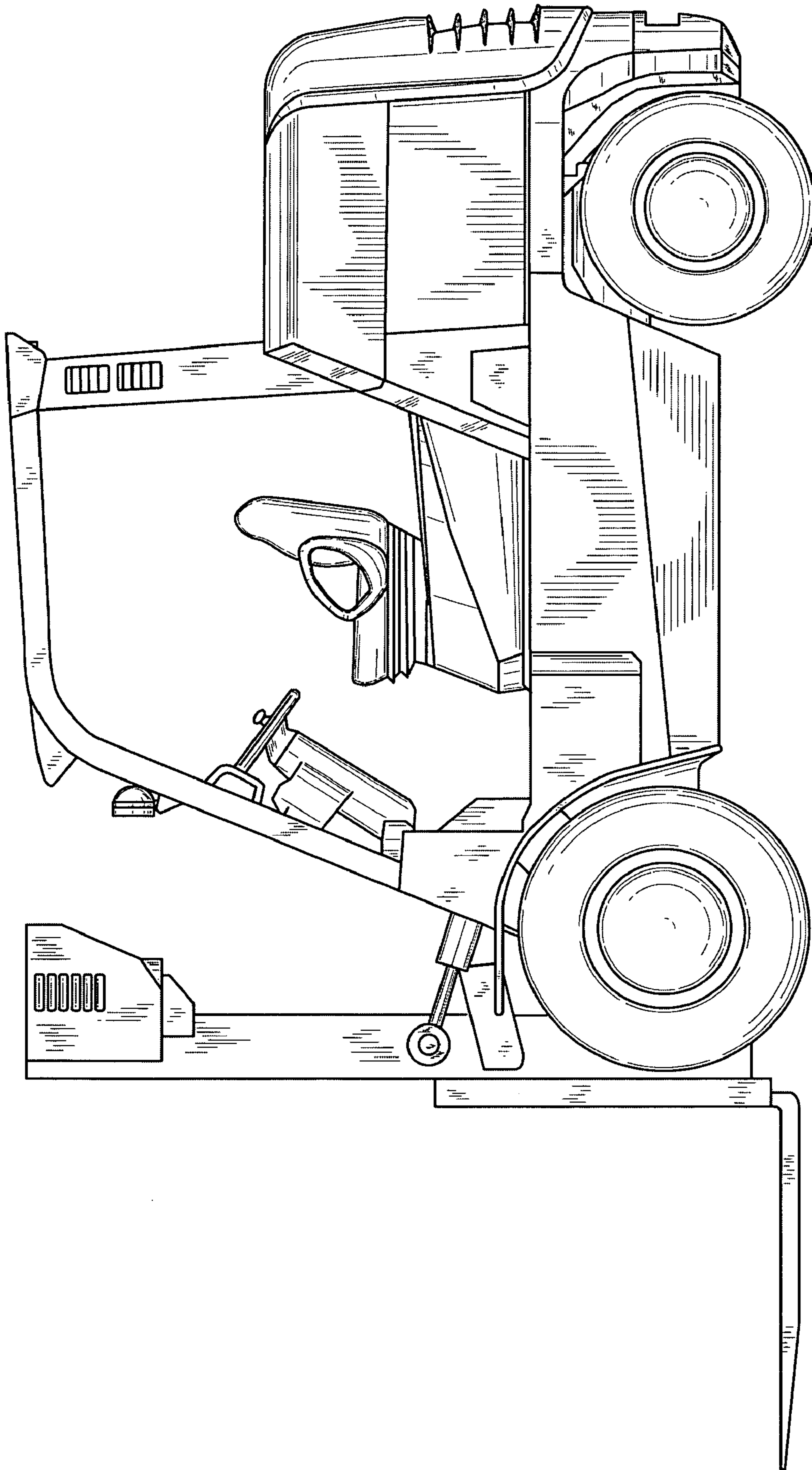
FIG. 5 is a top plan view thereof;

FIG. 6 is a bottom plan view thereof; and,

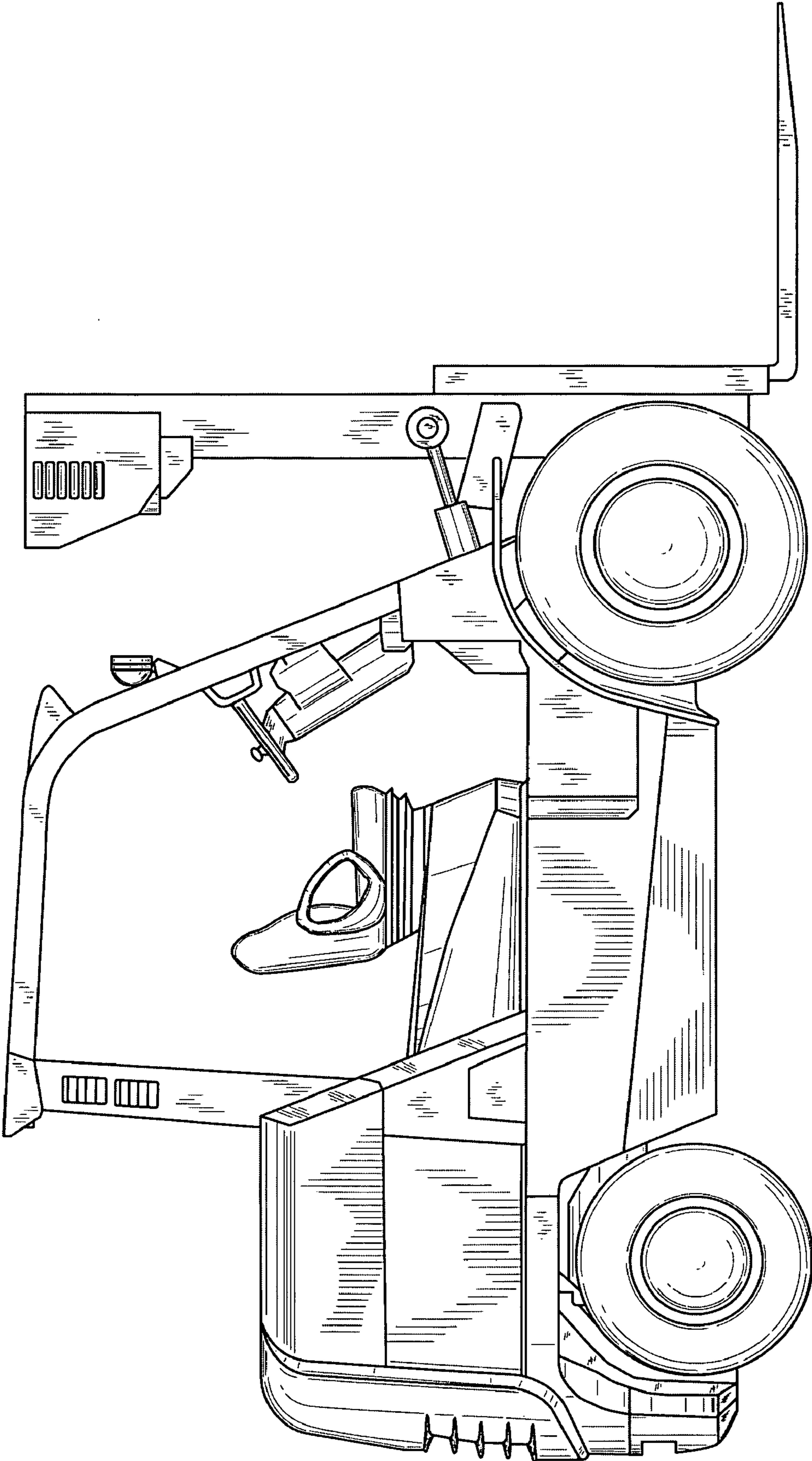
FIG. 7 is a rear perspective view thereof.

**1 Claim, 6 Drawing Sheets**

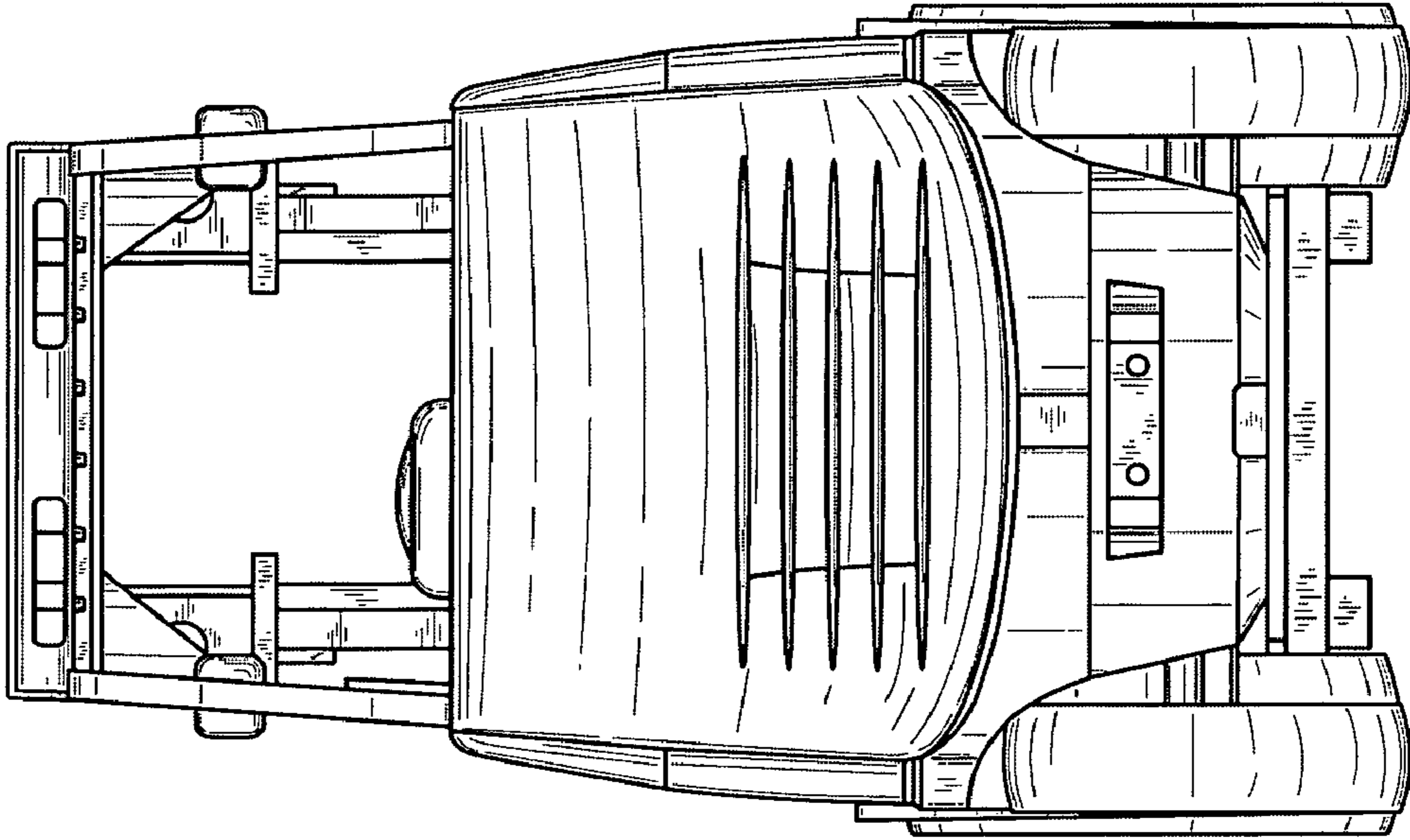




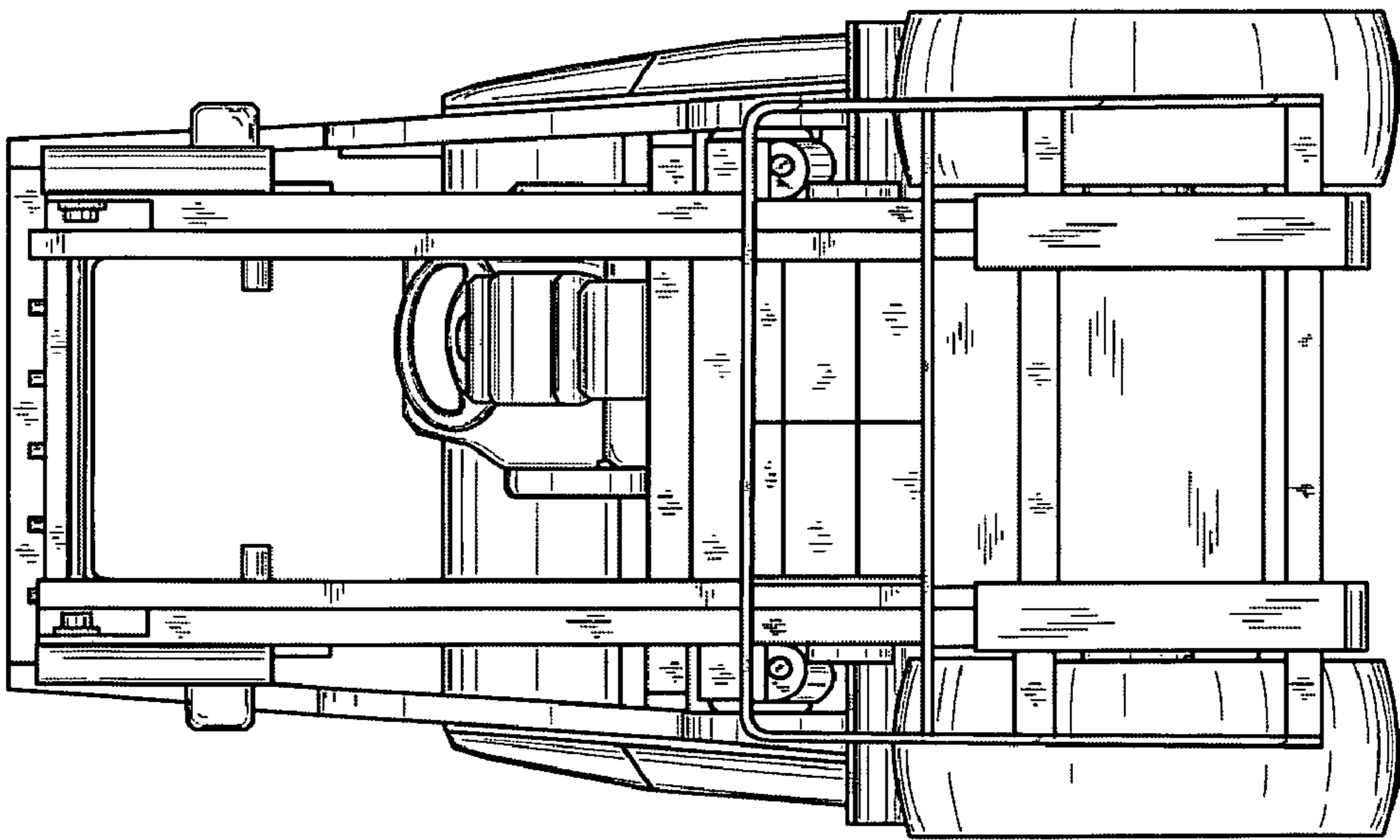
**FIG. 1**



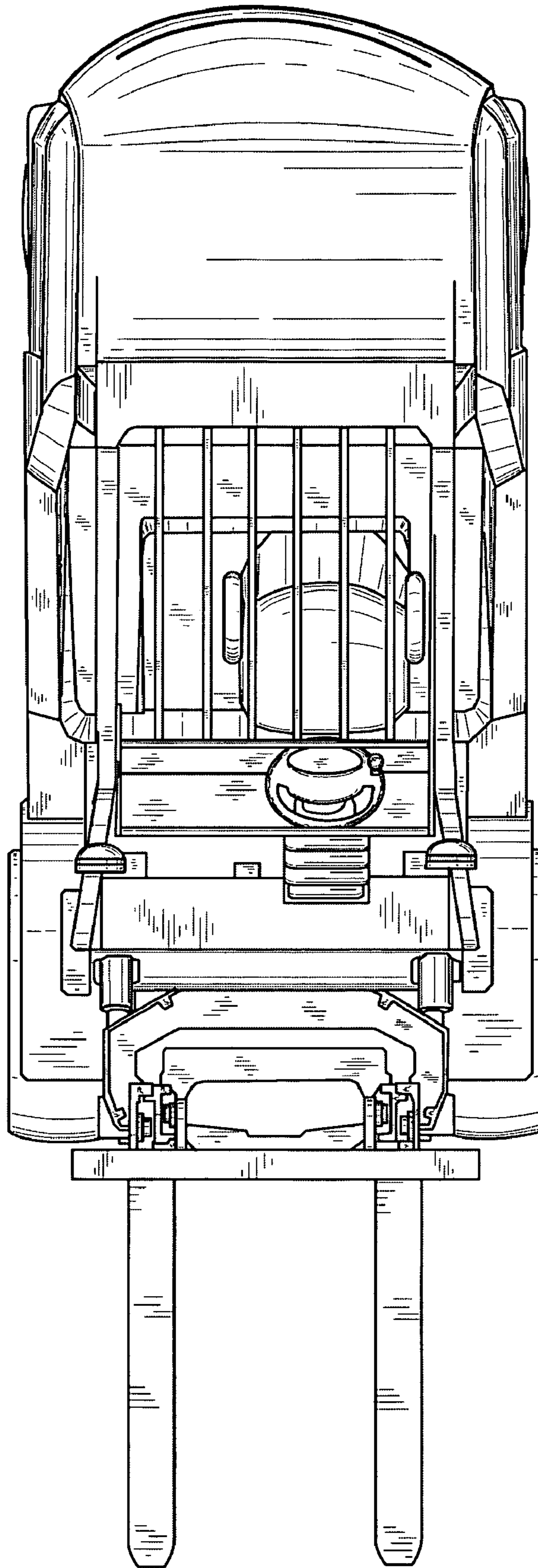
**FIG. 2**



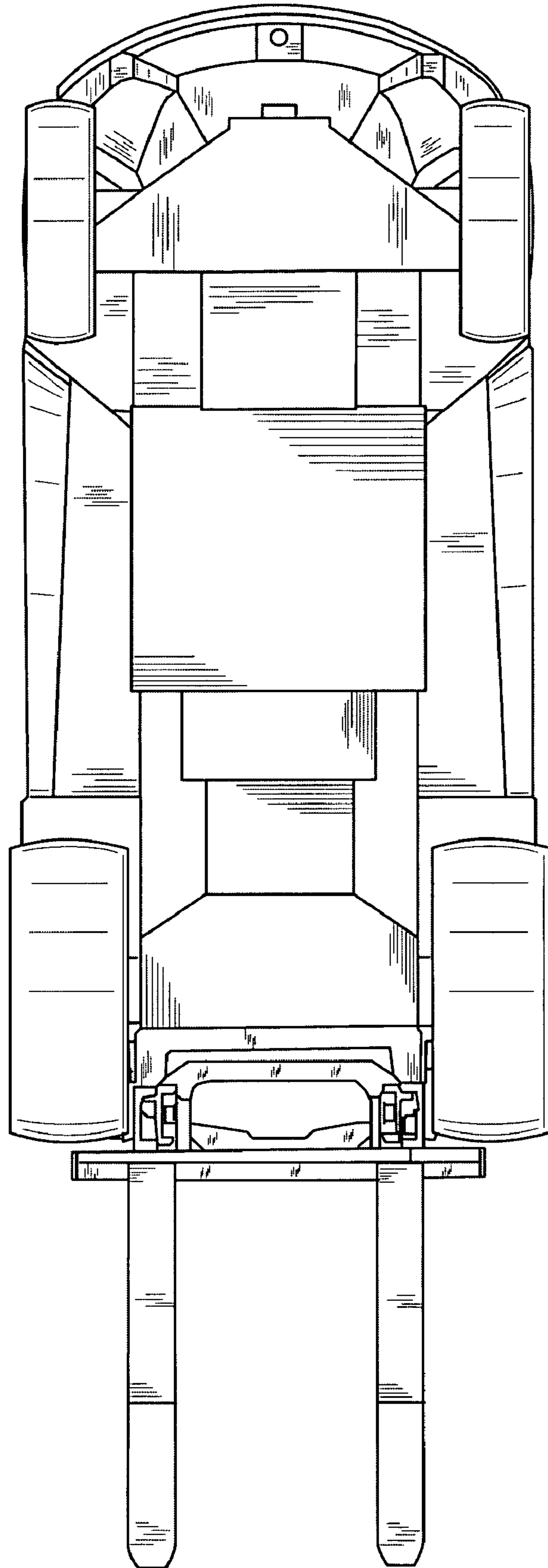
**FIG. 4**



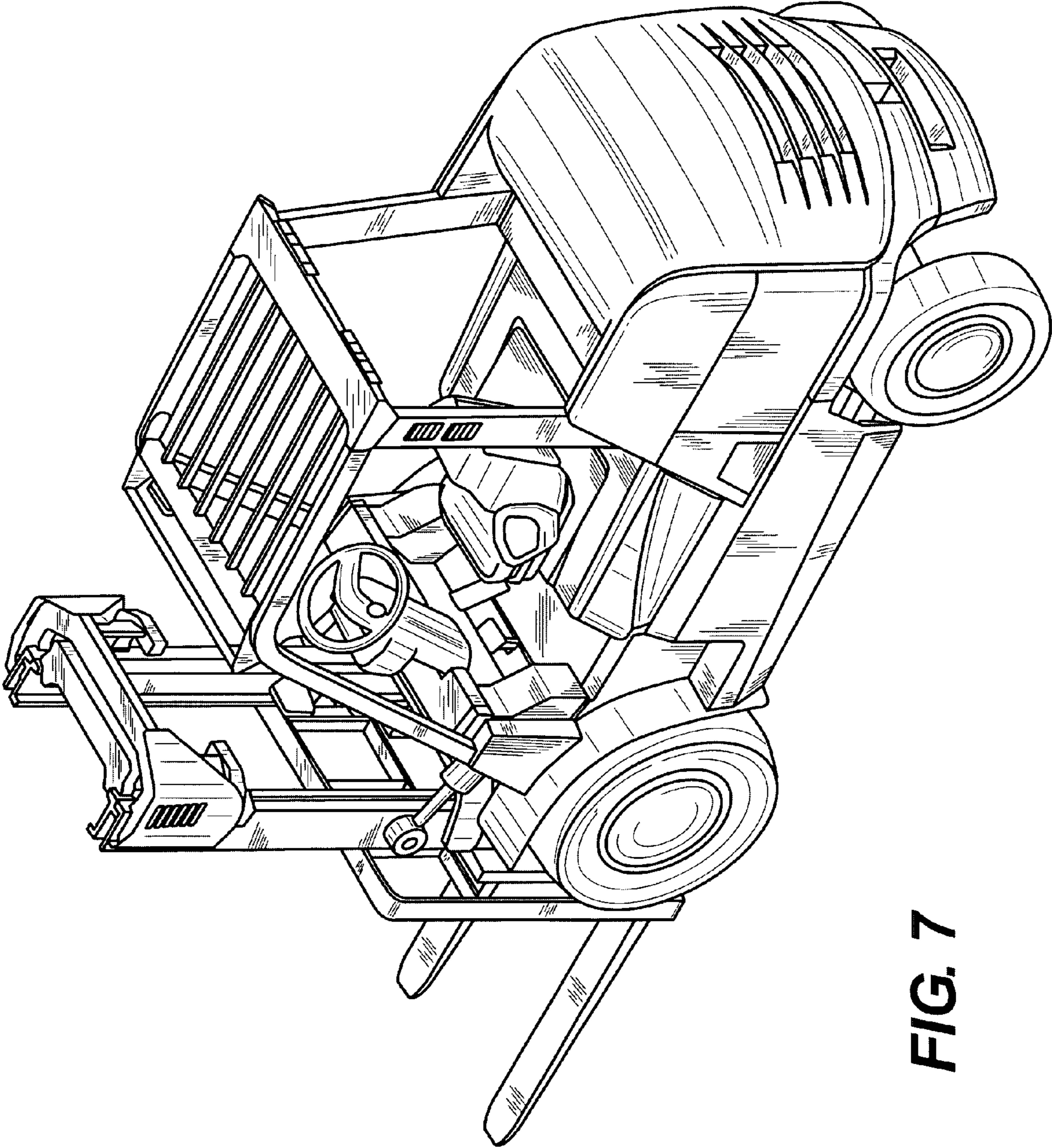
**FIG. 3**



**FIG. 5**



**FIG. 6**



**FIG. 7**