



US00D565811S

(12) **United States Design Patent**  
**Fjellman**

(10) **Patent No.:** **US D565,811 S**

(45) **Date of Patent:** **\*\* \*Apr. 1, 2008**

(54) **HANDHELD VACUUM**

(75) Inventor: **Oskar Fjellman**, Stockholm (SE)

(73) Assignee: **AB Electrolux**, Stockholm (SE)

(\*) Notice: This patent is subject to a terminal disclaimer.

(\*\*) Term: **14 Years**

(21) Appl. No.: **29/266,139**

(22) Filed: **Sep. 15, 2006**

(30) **Foreign Application Priority Data**

Mar. 16, 2006 (EM) ..... 000497664

(51) **LOC (8) Cl.** ..... **15-05**

(52) **U.S. Cl.** ..... **D32/18**

(58) **Field of Classification Search** ..... D32/17,  
D32/18, 21-22, 31; 15/1.52, 1.7, 4, 329,  
15/339, 344, 347, 351, 353, 361, 410-412,  
15/414, DIG. 1; 55/DIG. 3; D13/108; 320/115  
See application file for complete search history.

(56) **References Cited**

**U.S. PATENT DOCUMENTS**

D288,015 S	1/1987	Verdier et al.	
4,670,701 A	6/1987	Sako et al.	
D304,104 S	10/1989	Busalt et al.	
D307,656 S	5/1990	Yuen	
D307,657 S	5/1990	Li	
D356,191 S *	3/1995	Phelan	..... D32/18
D364,013 S	11/1995	Klingspor et al.	
D398,425 S	9/1998	Hudson	
D399,618 S	10/1998	Jacobs	
5,869,947 A	2/1999	Zahuranec et al.	
D421,671 S *	3/2000	Thomas et al.	..... D32/18
6,108,864 A	8/2000	Thomas et al.	

D440,719 S *	4/2001	Stratford	..... D32/18
D440,720 S *	4/2001	Stratford	..... D32/18
D441,151 S *	4/2001	Stratford	..... D32/18
D441,152 S *	4/2001	Stratford	..... D32/18
6,231,647 B1 *	5/2001	Cheng	..... 96/226
6,434,785 B1	8/2002	Vandenbelt et al.	
6,546,592 B1 *	4/2003	Cockburn et al.	..... 15/344
D483,160 S	12/2003	Houghton	
6,839,934 B2	1/2005	Houghton et al.	
D509,930 S *	9/2005	Stratford	..... D32/18
D515,258 S *	2/2006	Robson	..... D32/18
2005/0081321 A1	4/2005	Milligan et al.	

\* cited by examiner

*Primary Examiner*—Ruth McInroy

(74) *Attorney, Agent, or Firm*—Hunton & Williams

(57) **CLAIM**

I claim the ornamental design for a handheld vacuum, as shown and described.

**DESCRIPTION**

FIG. 1 is a rear isometric view of a handheld vacuum showing the claimed design.

FIG. 2 is a top plan view of the handheld vacuum.

FIG. 3 is a bottom plan view of the handheld vacuum.

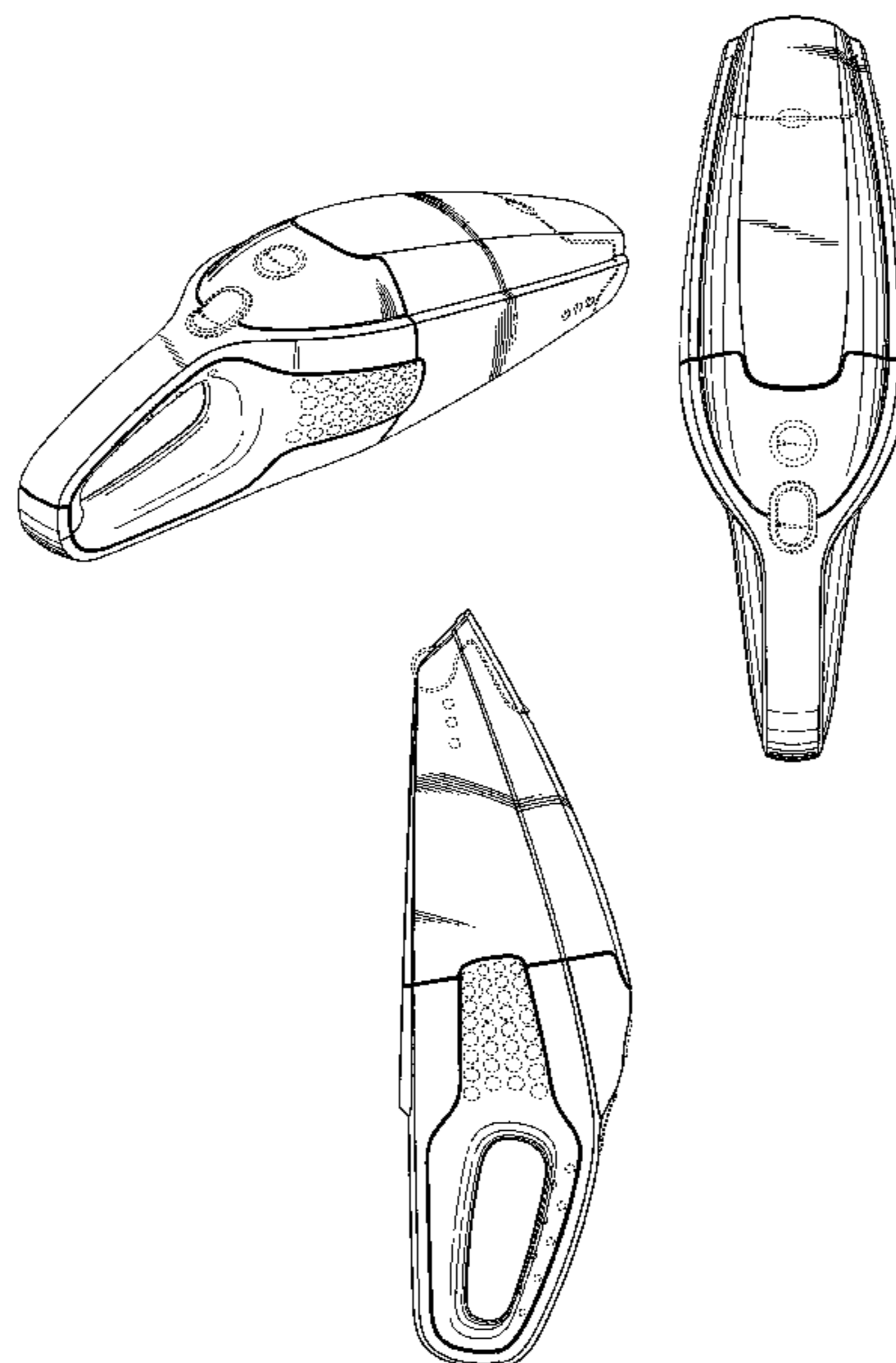
FIG. 4 is a left elevational view of the handheld vacuum, the right elevational view being a mirror image of the left elevational view.

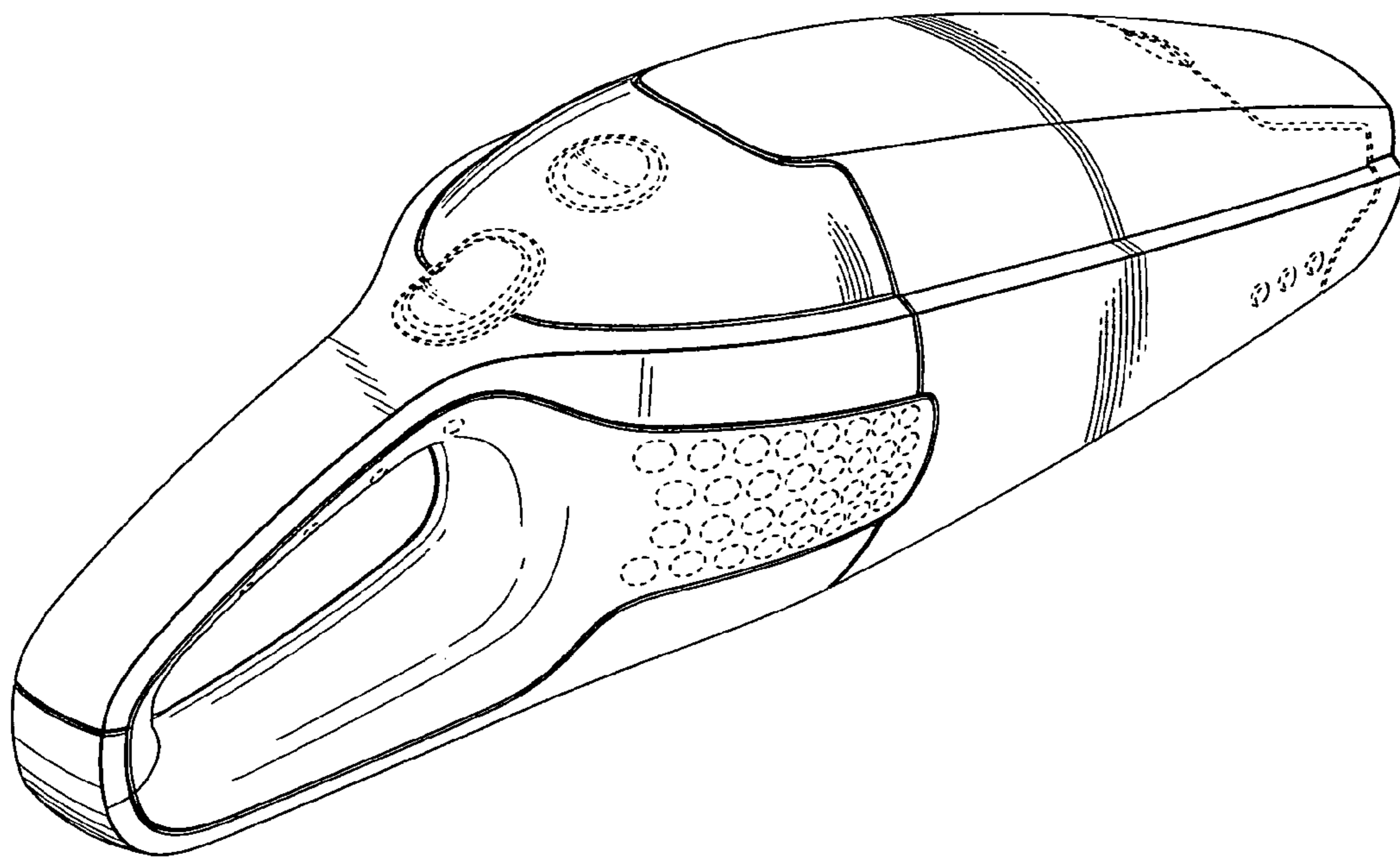
FIG. 5 is a front elevational view of the handheld vacuum; and,

FIG. 6 is a rear elevational view of the handheld vacuum.

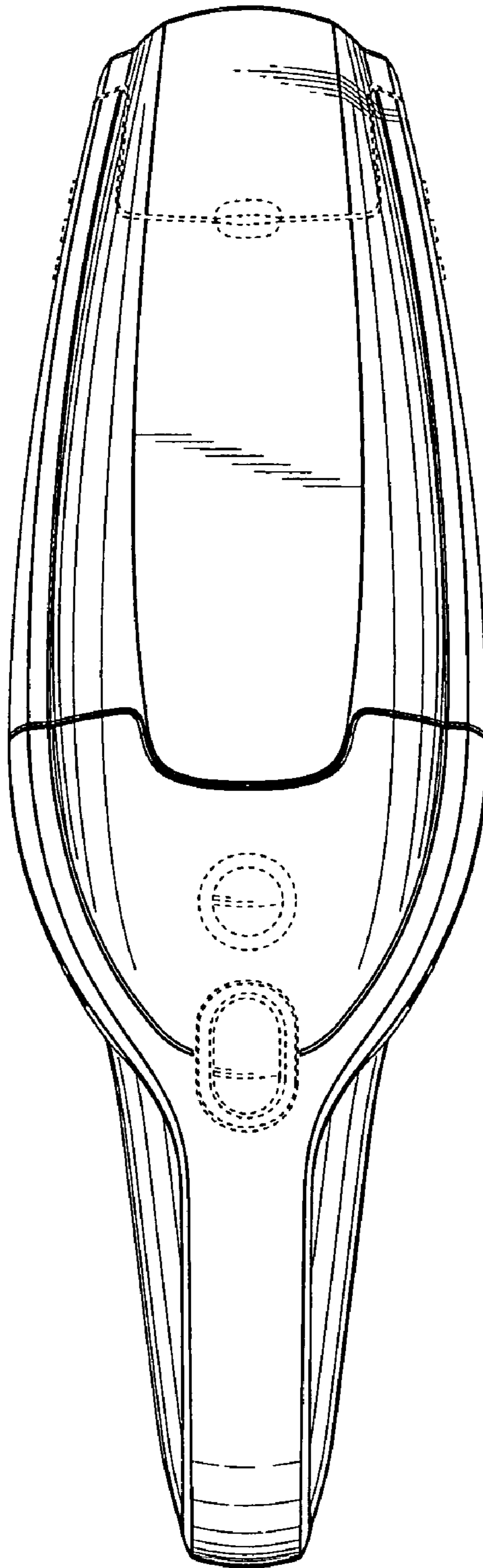
The details shown in broken lines form no part of the claimed design.

**1 Claim, 6 Drawing Sheets**

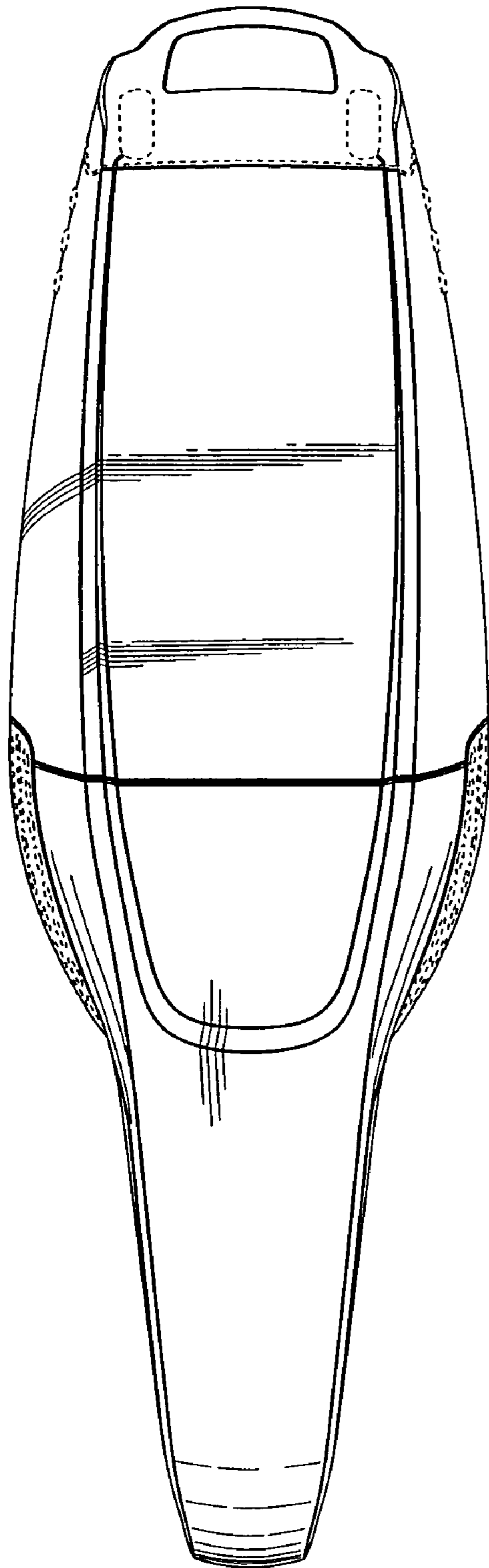




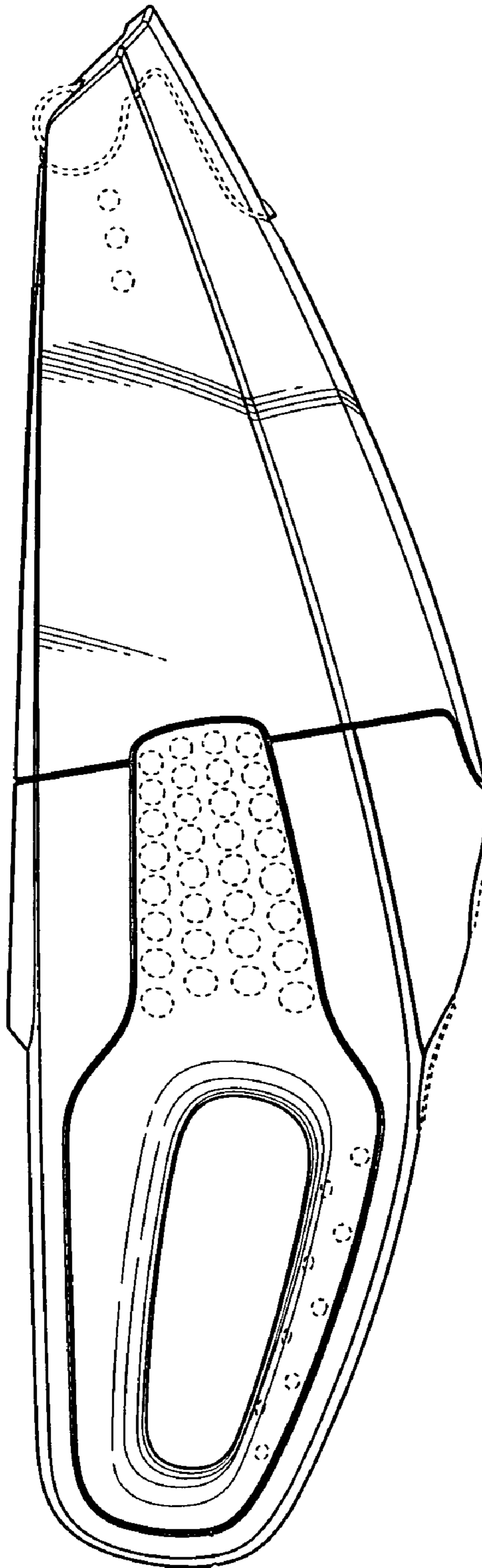
**Fig. 1**



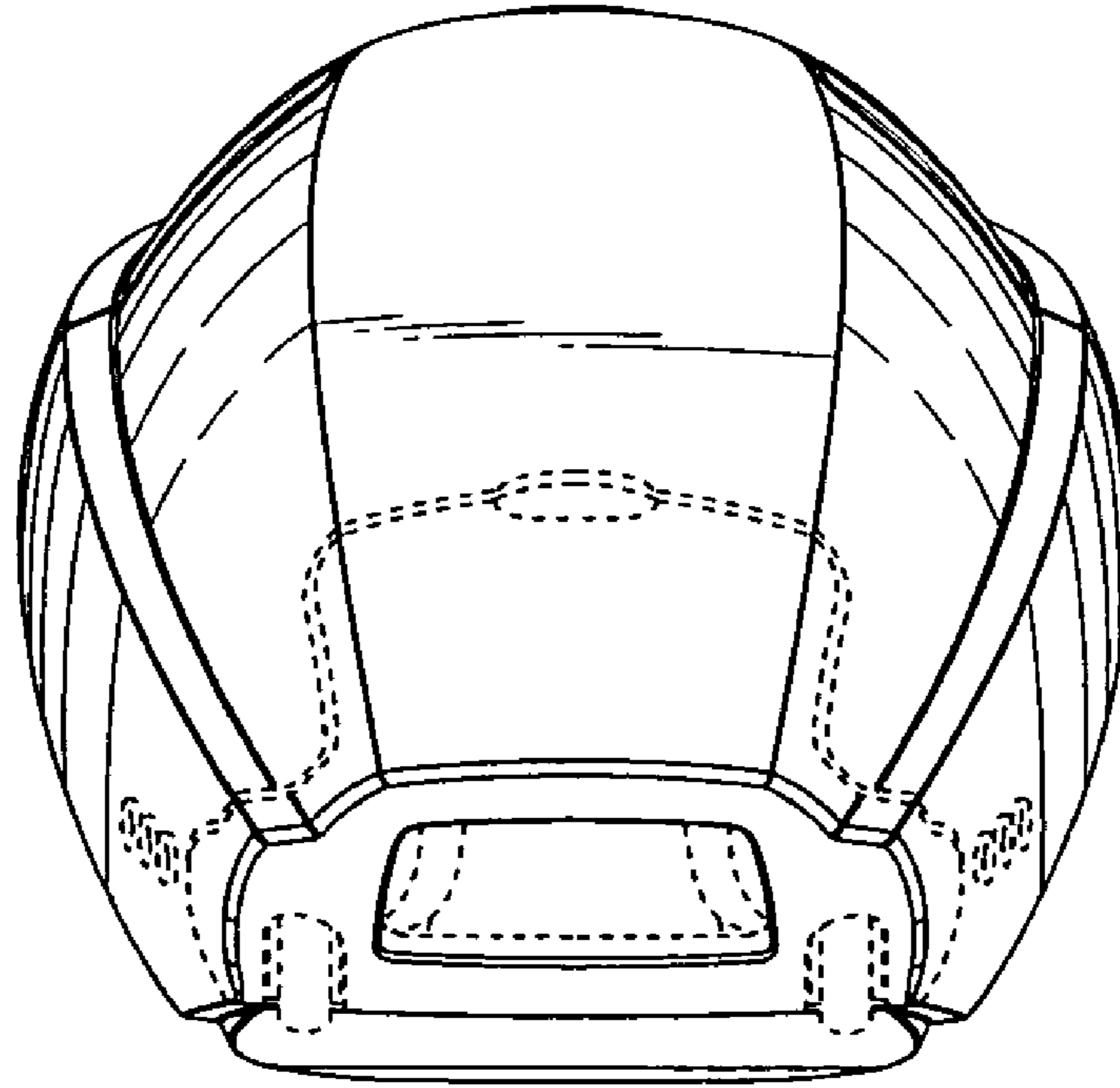
**Fig. 2**



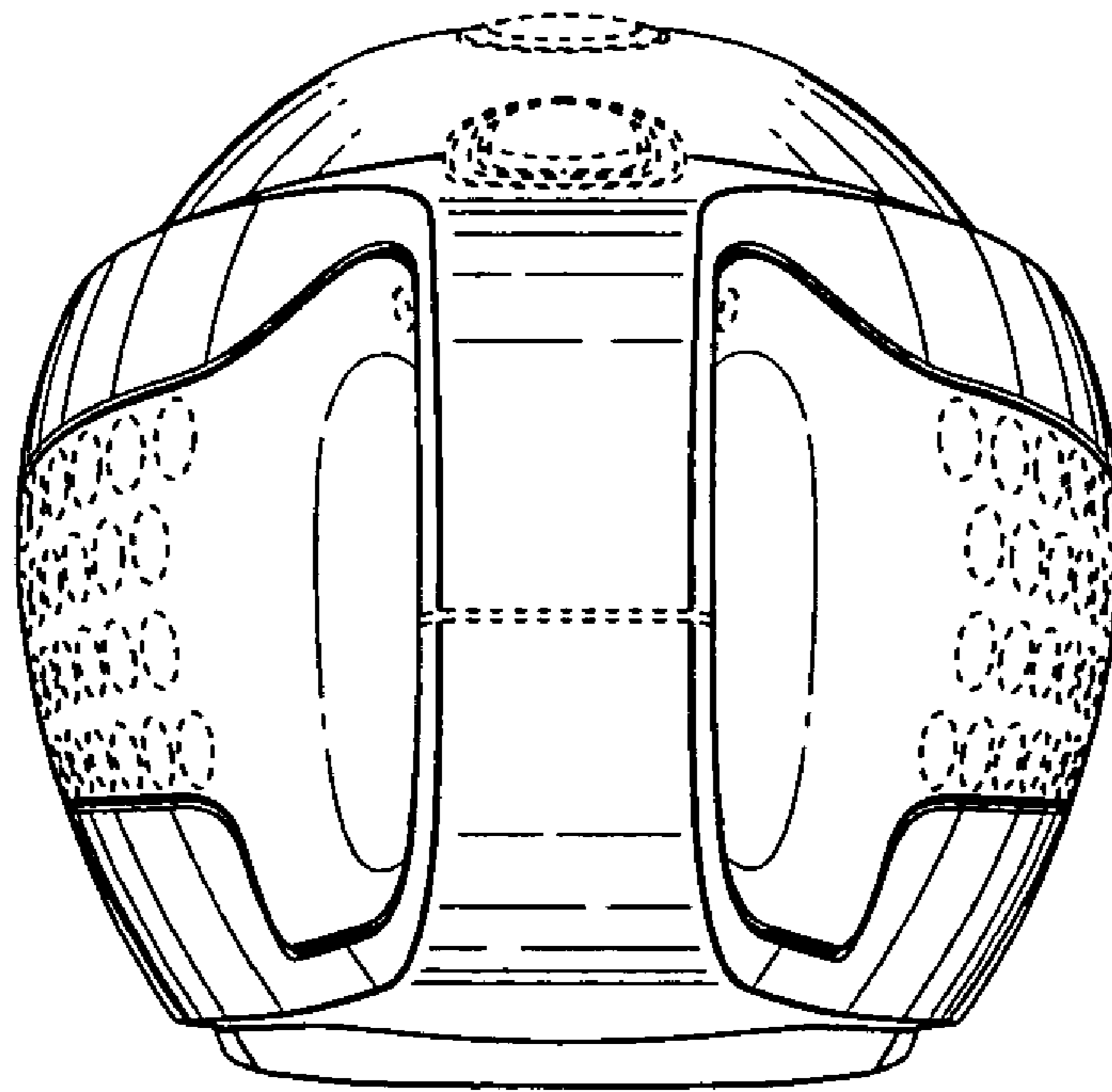
**Fig. 3**



**Fig. 4**



***Fig. 5***



***Fig. 6***