



US00D565707S

(12) **United States Design Patent**  
**Brockington et al.**

(10) **Patent No.:** **US D565,707 S**

(45) **Date of Patent:** **\*\* Apr. 1, 2008**

(54) **COUPLING FOR 3" RV SEWER HOSE**

(75) Inventors: **William T. Brockington**, Kernersville, NC (US); **Robert C. Mancari**, High Point, NC (US); **Clay D. Price**, Stokesdale, NC (US); **Jeffrey R. Russell**, Winston Salem, NC (US)

(73) Assignee: **Camco Manufacturing Inc.**, Greensboro, NC (US)

(\*\*) Term: **14 Years**

(21) Appl. No.: **29/268,225**

(22) Filed: **Oct. 30, 2006**

(51) **LOC (8) Cl.** ..... **23-01**

(52) **U.S. Cl.** ..... **D23/262**

(58) **Field of Classification Search** ..... D23/266;  
285/11-12, 7, 177, 394, 395, 903, 307, 358,  
285/179-183, 423; 4/321, 323; 292/58-59  
See application file for complete search history.

(56) **References Cited**

U.S. PATENT DOCUMENTS

549,733	A	11/1895	Limbert	
1,731,320	A *	10/1929	Ratcliffe	285/18
2,831,711	A *	4/1958	Leadbetter	285/238
3,459,445	A *	8/1969	Parkhill	285/302
3,785,682	A	1/1974	Schaller et al.	
3,899,198	A	8/1975	Maroschak	
4,660,860	A	4/1987	Todd	
5,046,763	A *	9/1991	Martucci et al.	285/81
6,231,090	B1 *	5/2001	Fukao et al.	285/340
D483,095	S *	12/2003	Snyder et al.	D23/262

D493,214	S *	7/2004	Snyder et al.	D23/262
D495,404	S *	8/2004	Wilk et al.	D23/262
D517,665	S *	3/2006	Wilk et al.	D23/262
D534,796	S *	1/2007	Falkenburg	D9/434
2004/0007875	A1 *	1/2004	Bishop et al.	285/369

OTHER PUBLICATIONS

Ref. No. 1, Easy Slip Internal Hose Coupler (P/N 4439163), Camco Website (www.camco.net), Jul. 26, 2006.

Ref. No. 2, EZ Coupler (P/N F02-3102), Valterra Website (www.valterra.com), Sep. 25, 2006.

\* cited by examiner

*Primary Examiner*—Ian Simmons

*Assistant Examiner*—Eric L Goodman

(57) **CLAIM**

The ornamental design for a coupling for 3" RV sewer hose, as shown and described.

**DESCRIPTION**

FIG. 1 is an isometric view of a coupling for 3" RV sewer hose according to the invention;

FIG. 2 is a front elevational view according to the invention, the rear elevational view being a mirror image;

FIG. 3 is a right elevational view according to the invention, the left elevational view being a mirror image;

FIG. 4 is a top plan view according to the invention, the bottom plan view being a mirror image; and,

FIG. 5 is a top, rear right perspective view according to the invention.

**1 Claim, 3 Drawing Sheets**

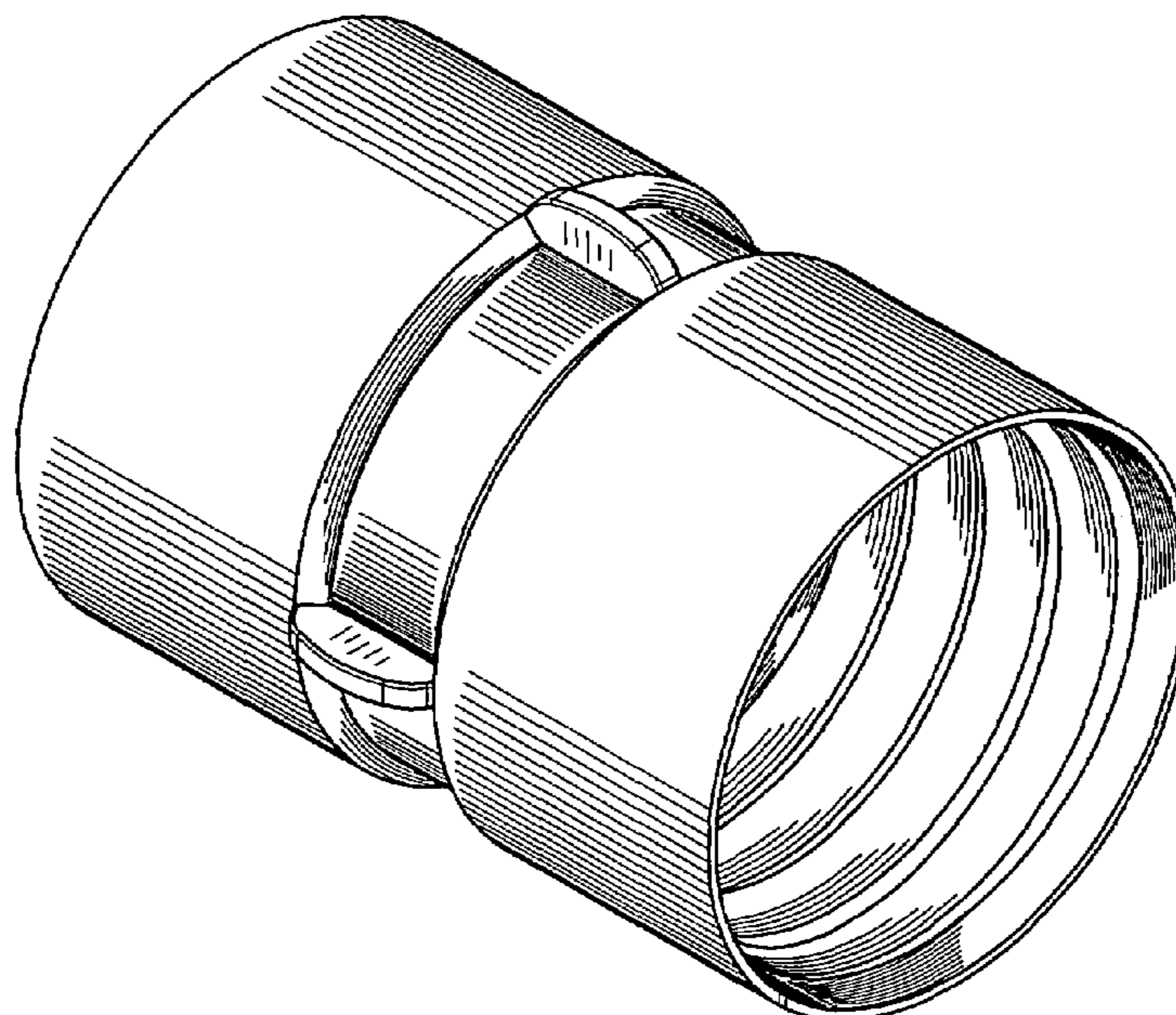

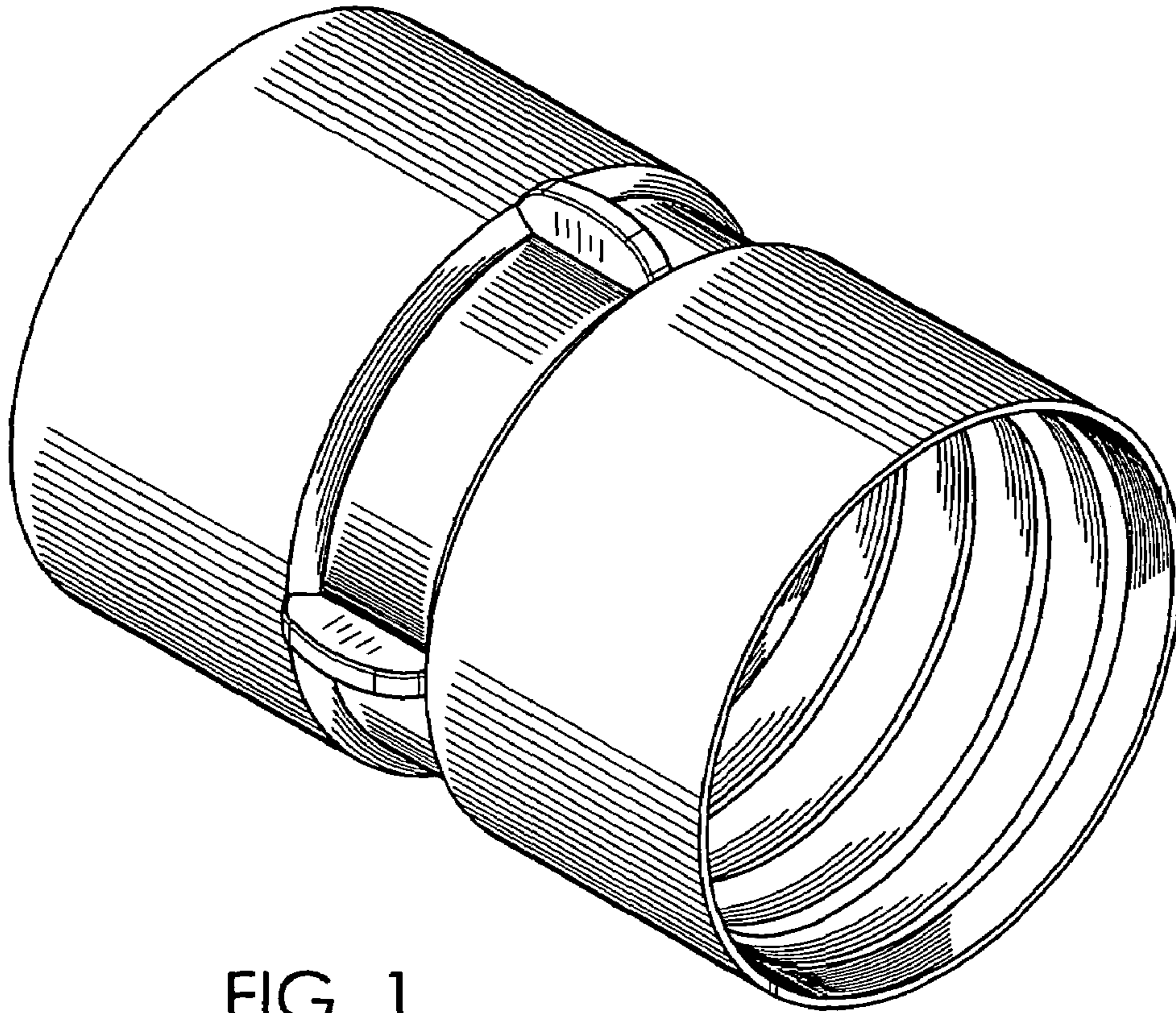

FIG. 1

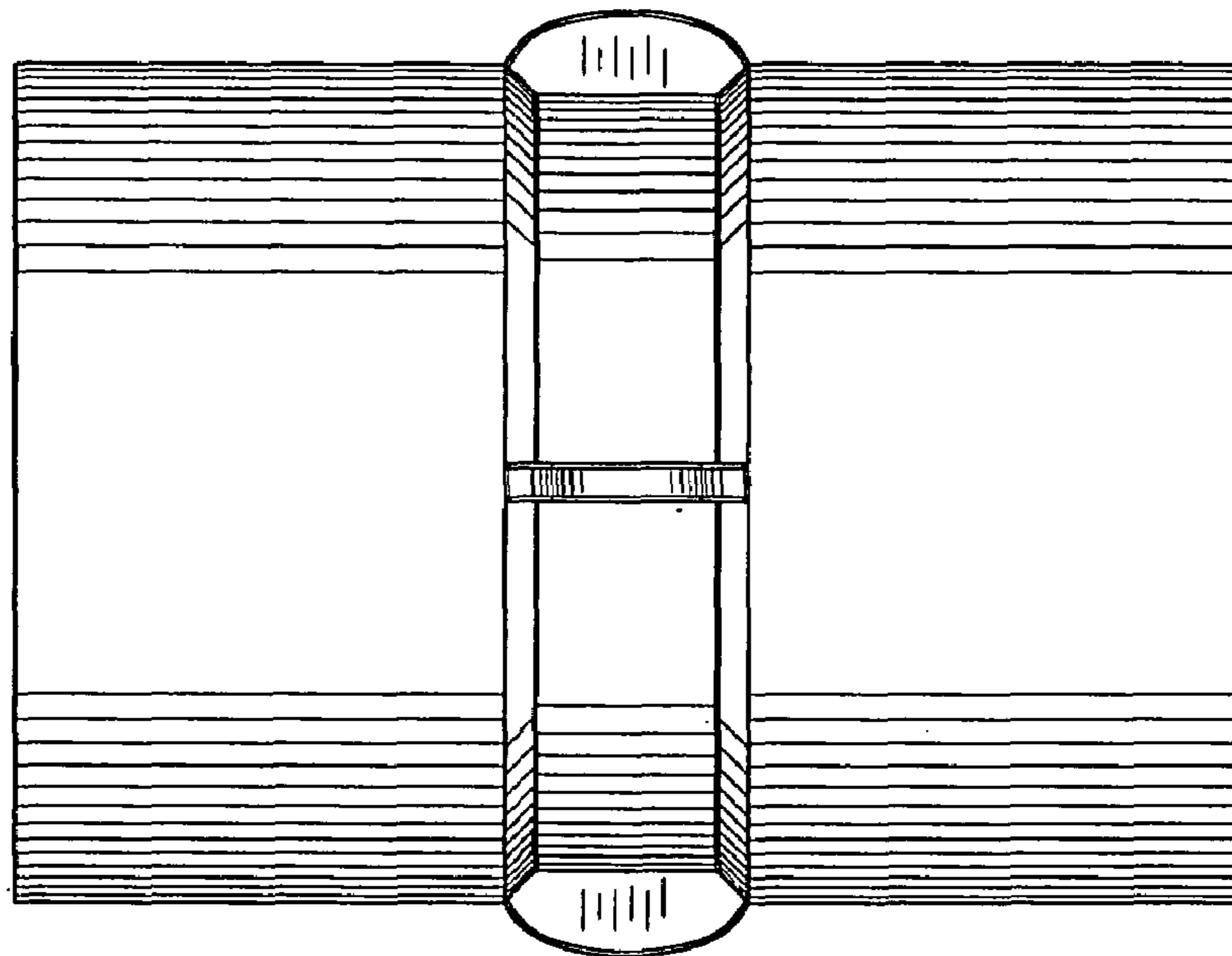

FIG. 2

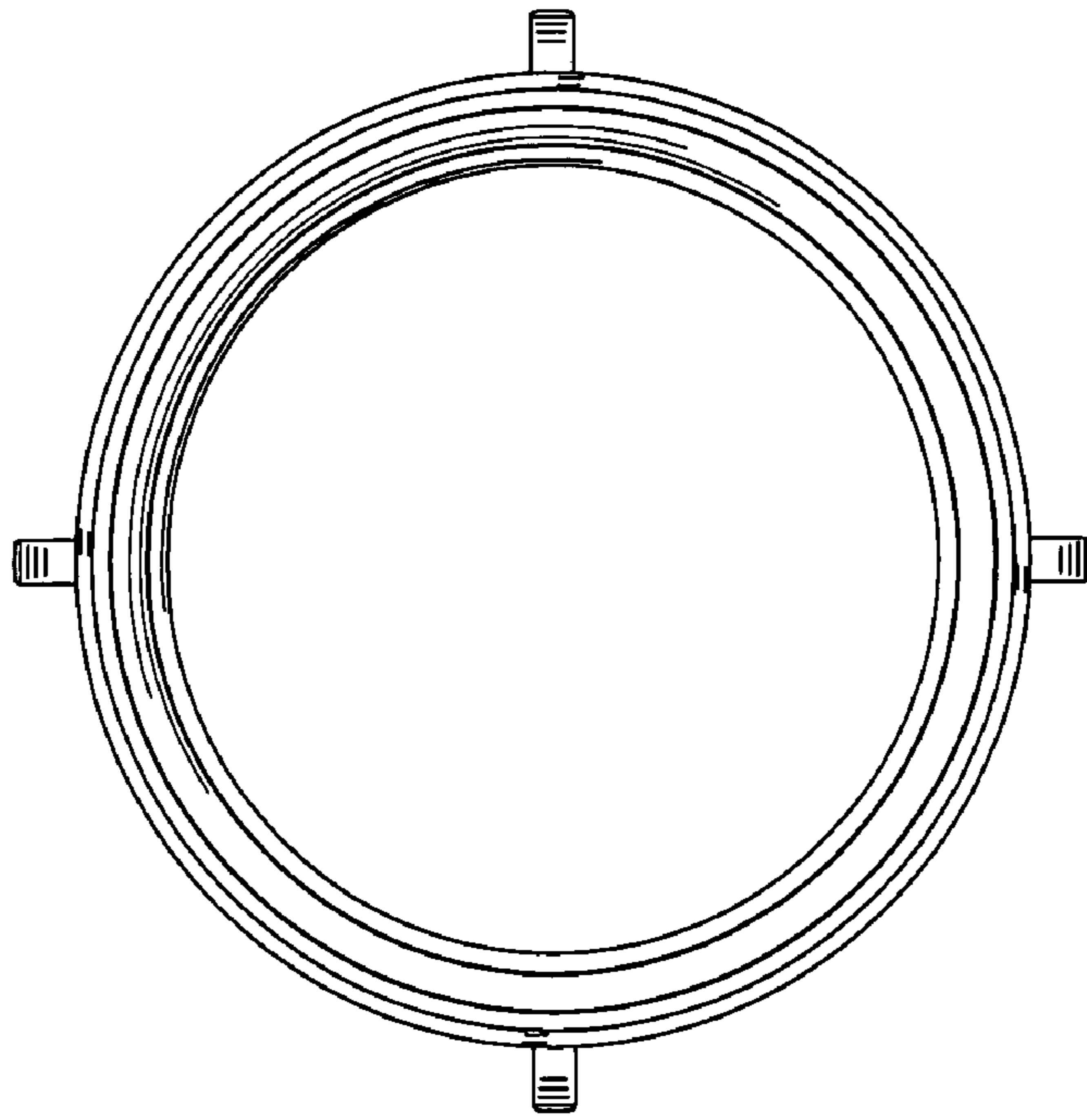

FIG. 3

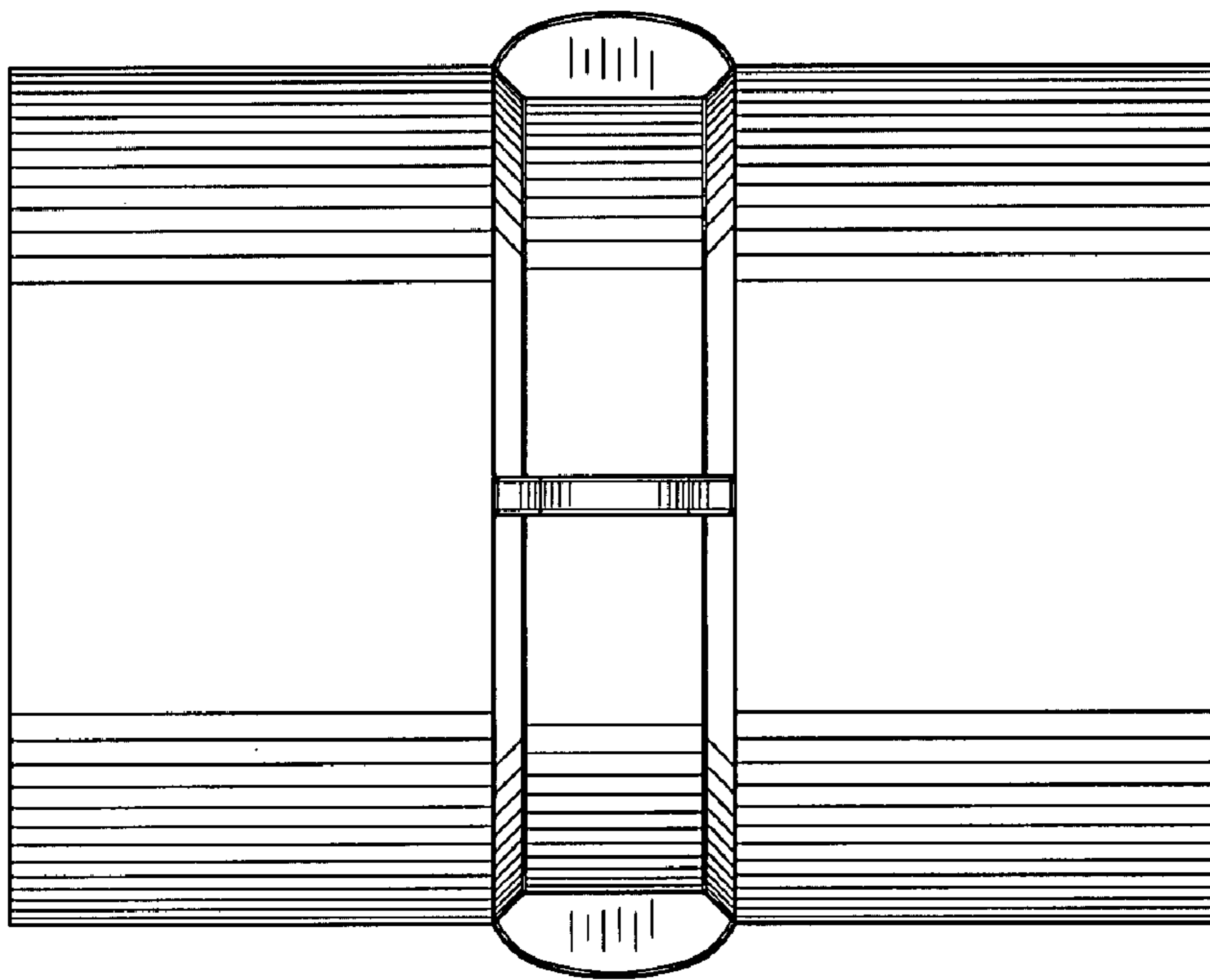

FIG. 4

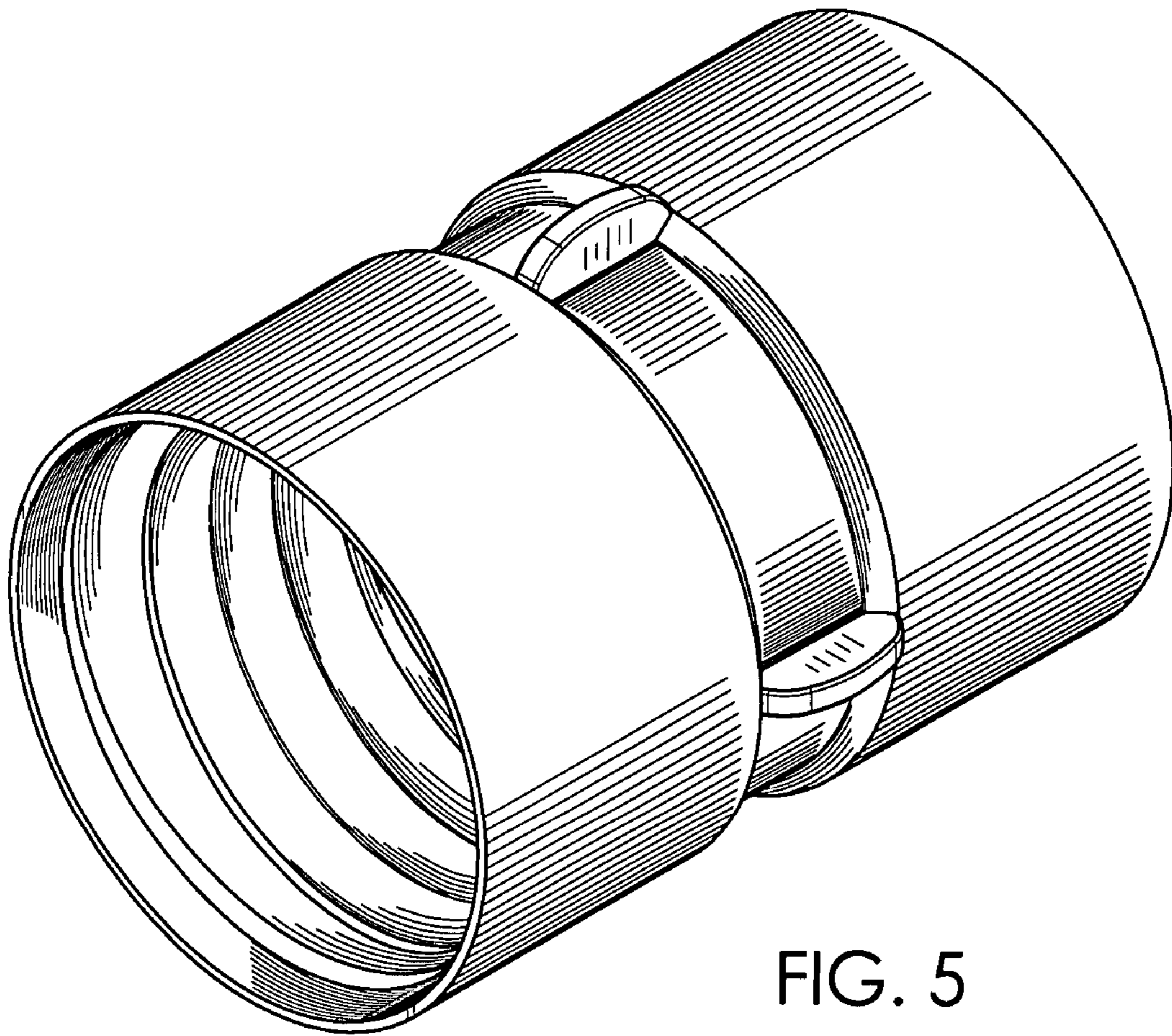

FIG. 5