



US00D565503S

(12) **United States Design Patent** (10) **Patent No.:** **US D565,503 S**
Tanaka (45) **Date of Patent:** **** Apr. 1, 2008**

(54) **AUTOMOBILE TIRE**
(75) Inventor: **Masaya Tanaka**, Osaka (JP)
(73) Assignee: **Toyo Tire & Rubber Co., Ltd.**, Osaka (JP)
(**) Term: **14 Years**
(21) Appl. No.: **29/287,125**
(22) Filed: **Jun. 29, 2007**
(30) **Foreign Application Priority Data**
May 28, 2007 (JP) 2007-016924

Primary Examiner—Stacia Cadmus
(74) *Attorney, Agent, or Firm*—Westerman, Hattori, Daniels & Adrian, LLP.

(57) **CLAIM**

The ornamental design for an automobile tire, as shown and described.

(51) **LOC (8) Cl.** **12-15**
(52) **U.S. Cl.** **D12/605**
(58) **Field of Classification Search** D12/544,
D12/579, 600, 605; 152/523, 524, DIG. 12
See application file for complete search history.

DESCRIPTION

FIG. 1 is a front view of the automobile tire;
FIG. 2 is a rear view of the automobile tire;
FIG. 3 is a left-side view of the automobile tire;
FIG. 4 is a top view of the automobile tire;
FIG. 5 is a perspective view of the automobile tire;
FIG. 6 is an enlarged view of the front (partially) of the automobile tire; and,
FIG. 7 is an enlarged cross-section view taken along the line A1—A2 in FIG. 6.

(56) **References Cited**
U.S. PATENT DOCUMENTS
D543,499 S * 5/2007 Shondel D12/605
D546,273 S * 7/2007 Dumigan D12/605
D549,165 S * 8/2007 Shondel et al. D12/605

The broken line showing of environment is for illustrative purposes only and forms no part of the claimed design.

FOREIGN PATENT DOCUMENTS
JP 1159389 11/2002

* cited by examiner

1 Claim, 7 Drawing Sheets

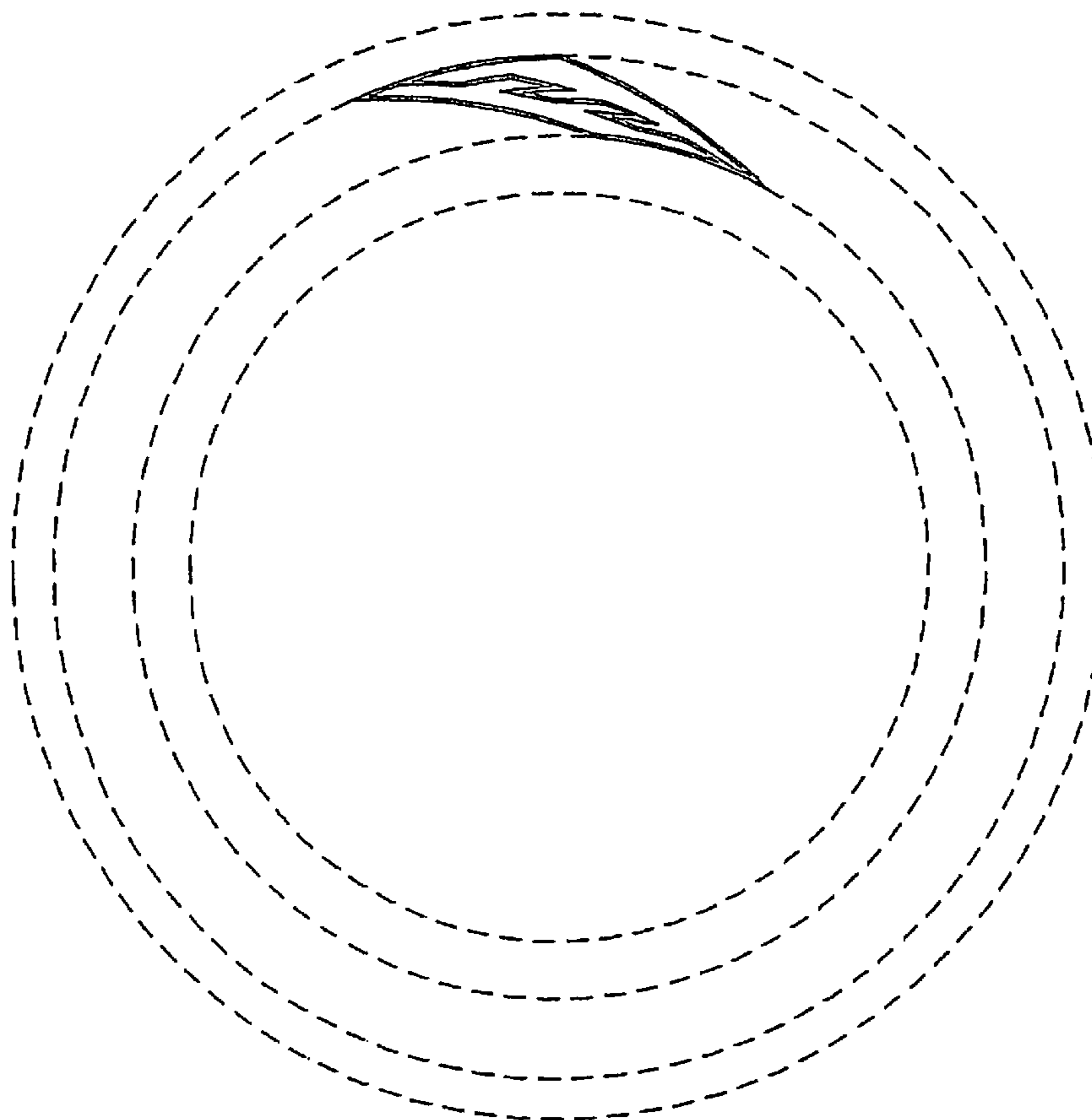

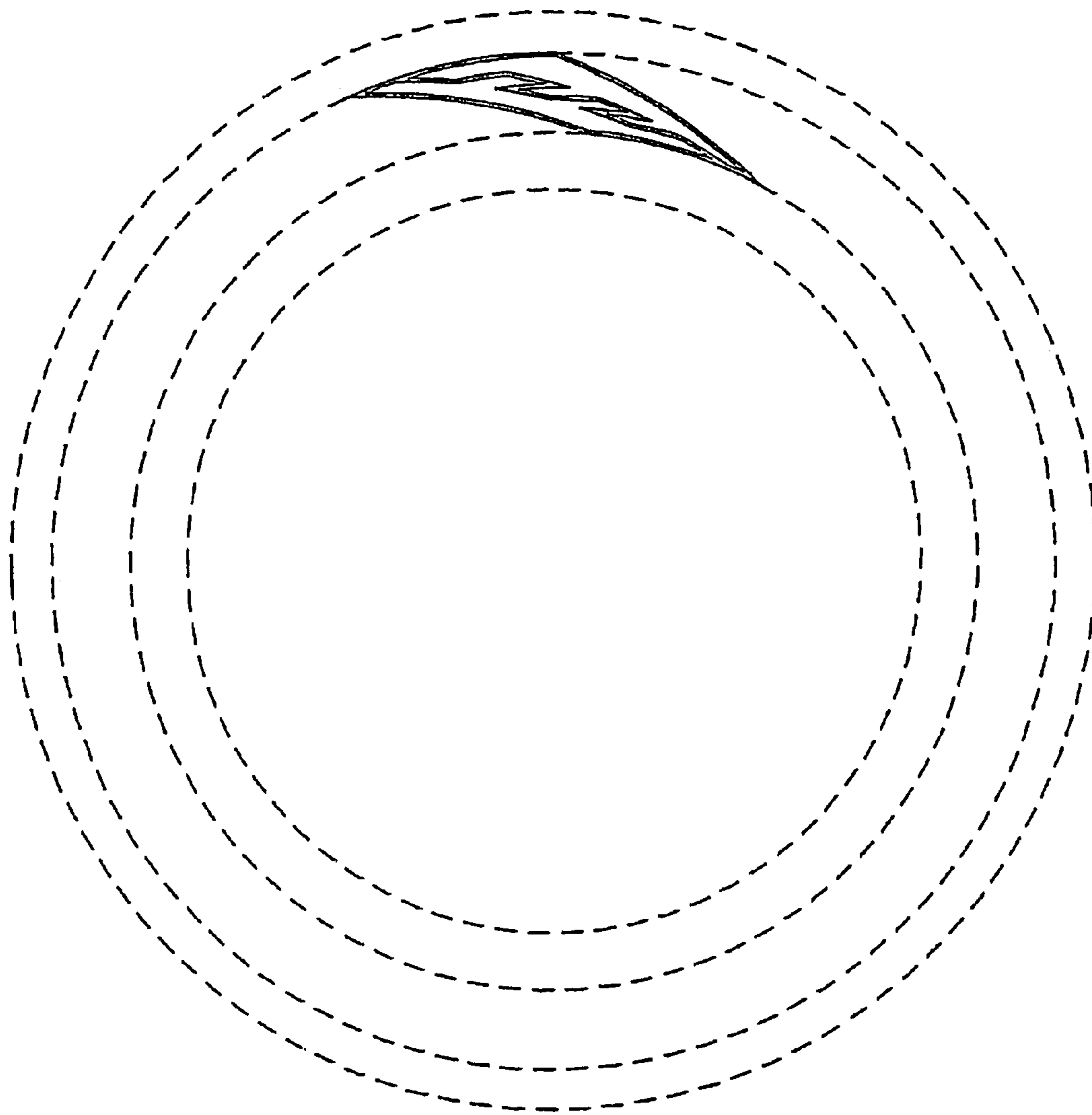

FIG. 1

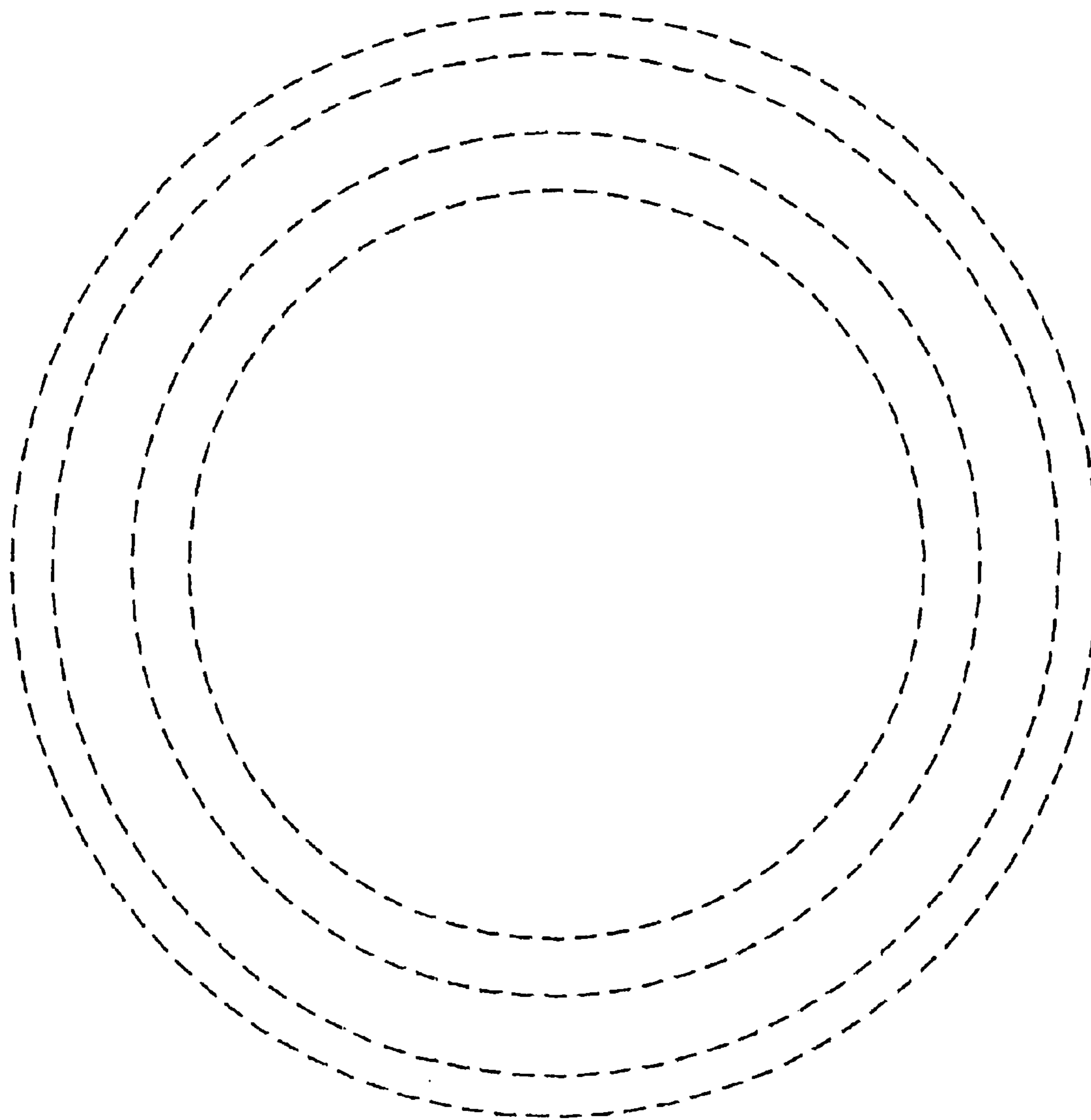

FIG.2

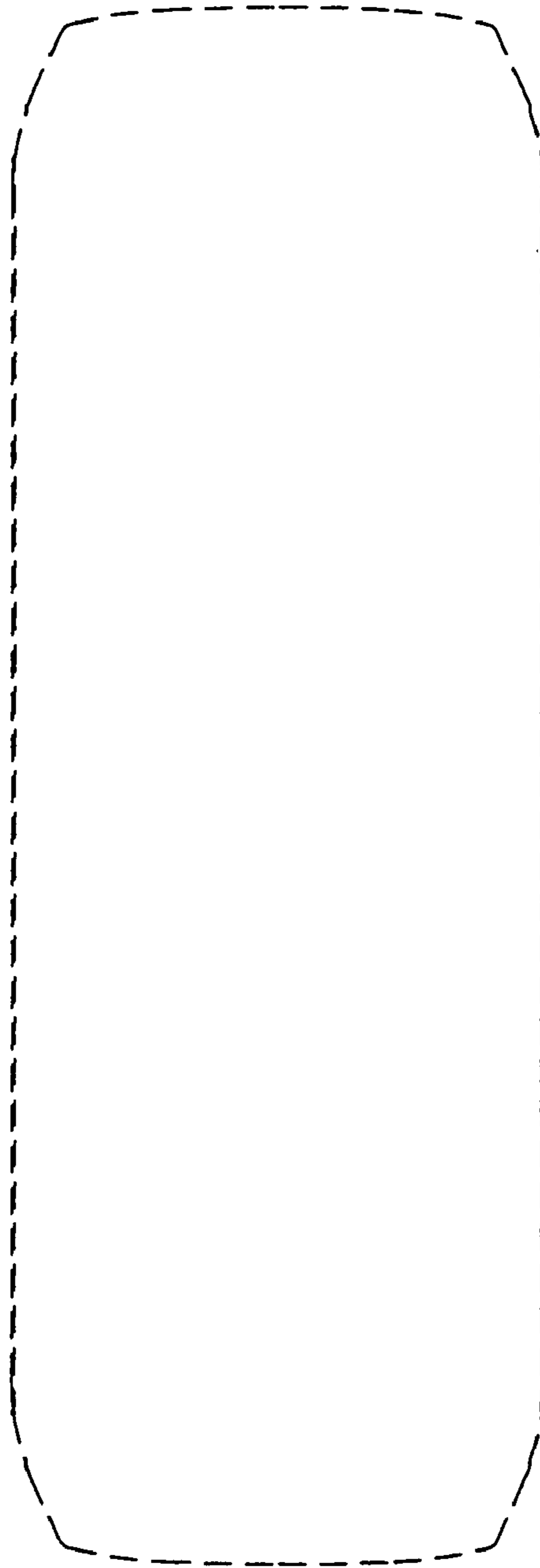

FIG.3

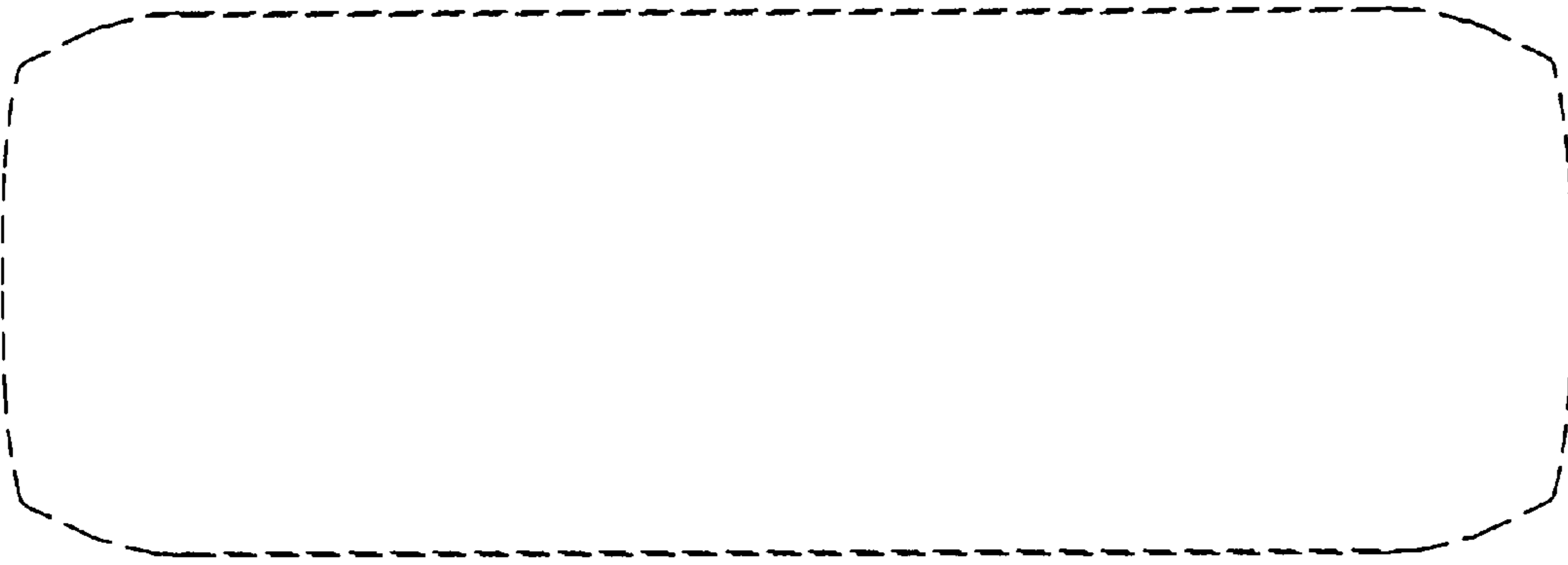

FIG.4

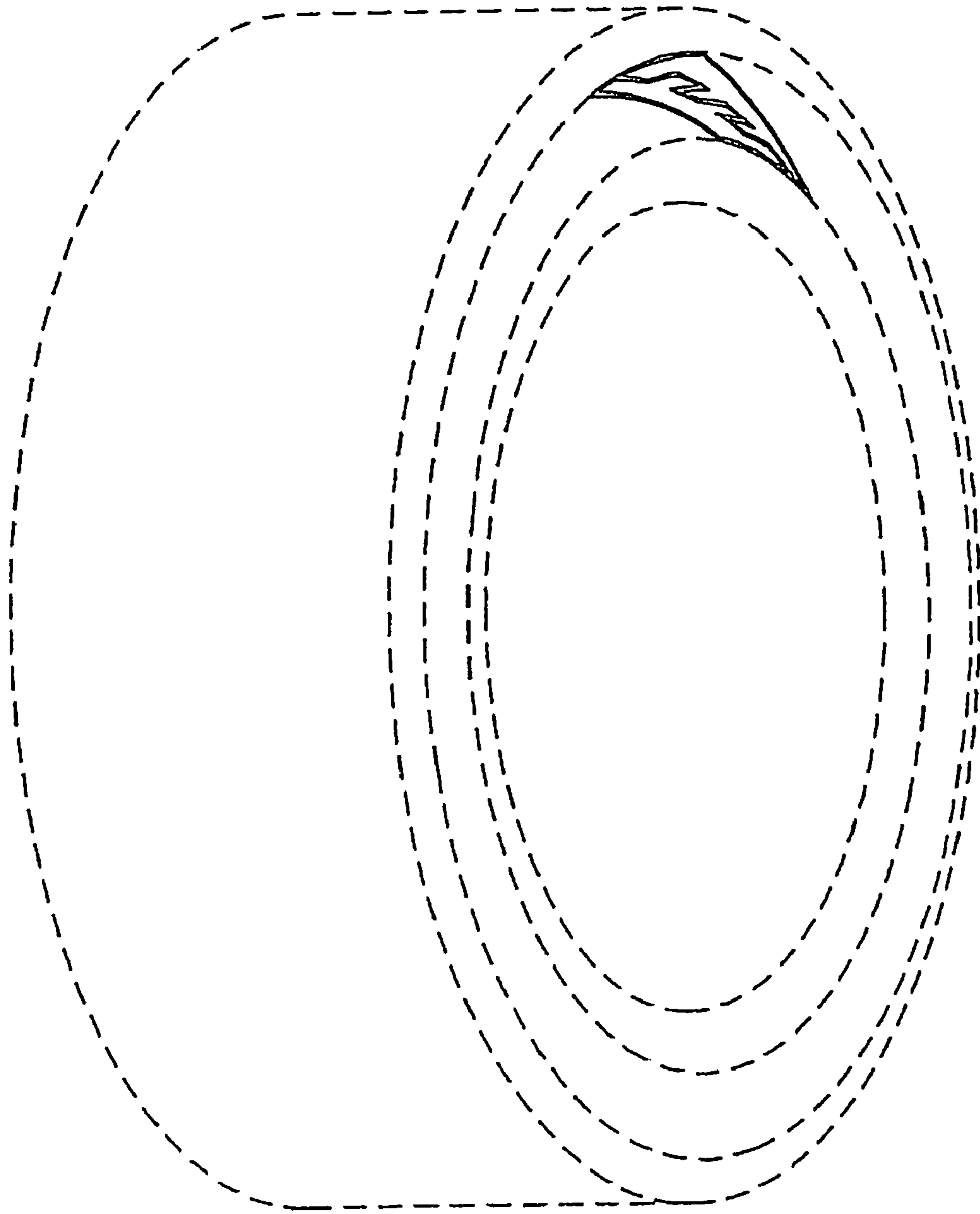

FIG.5

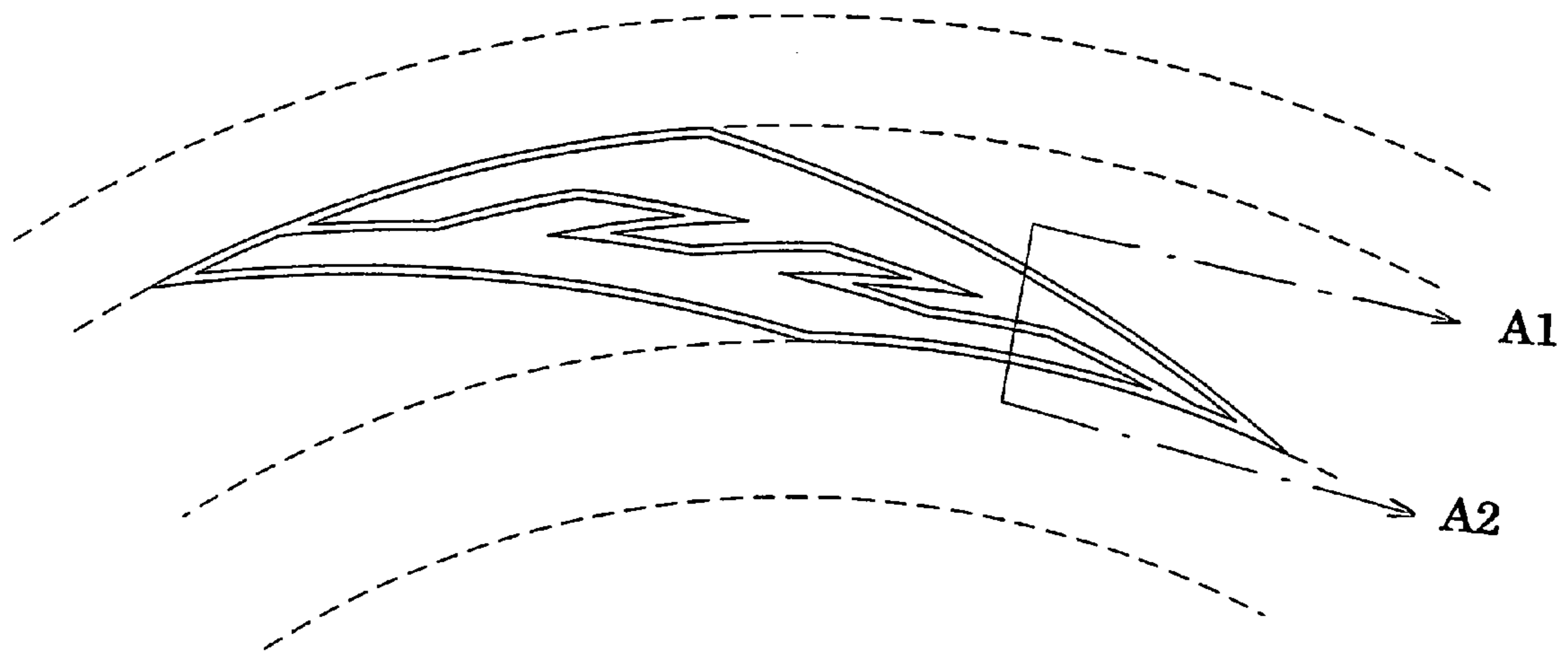

FIG.6

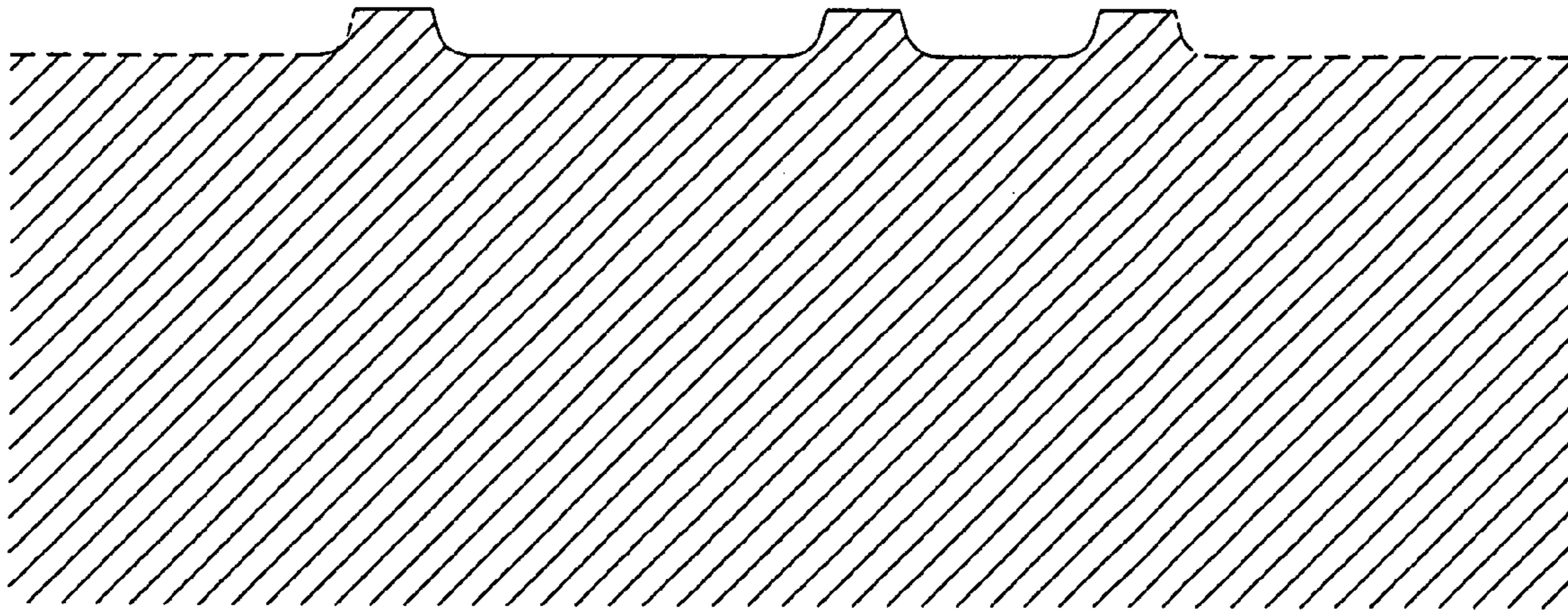

FIG.7