

US00D564947S

(12) **United States Design Patent**
Garcia

(10) **Patent No.:** **US D564,947 S**
(45) **Date of Patent:** **** Mar. 25, 2008**

(54) **MOTORCYCLE FRAME**

3,016,967 A 1/1962 Rehfeld
D456,748 S 5/2002 Keating et al.
D482,640 S 11/2003 TaMuRa et al.
D531,936 S 11/2006 Ito et al.

(75) Inventor: **Keith Garcia**, Hanford, CA (US)

(73) Assignee: **Big Bear American Made Choppers, Inc.**, Big Bear, CA (US)

(**) Term: **14 Years**

(21) Appl. No.: **29/297,743**

(22) Filed: **Nov. 16, 2007**

Primary Examiner—Cathron Brooks
Assistant Examiner—Linda Brooks
(74) *Attorney, Agent, or Firm*—Christie, Parker & Hale, LLP.

(57) **CLAIM**

The ornamental design for a motorcycle frame, as shown and described.

Related U.S. Application Data

(62) Division of application No. 29/273,022, filed on Feb. 23, 2007.

DESCRIPTION

(51) **LOC (8) Cl.** **12-11**
(52) **U.S. Cl.** **D12/110**
(58) **Field of Classification Search** D12/110,
D12/117, 410, 409; 180/219; 280/288.1–288.4,
280/281.1; 224/42.11, 400, 412, 418, 419,
224/425–435

FIG. 1 is a perspective view showing my new design;
FIG. 2 is a right side view of FIG. 1;
FIG. 3 is a left side view of FIG. 1;
FIG. 4 is a top side view of FIG. 1;
FIG. 5 is a front side view of FIG. 1; and,
FIG. 6 is a rear side view of FIG. 1.

See application file for complete search history.

The portions shown in broken lines form no part of the claimed design.

(56) **References Cited**

U.S. PATENT DOCUMENTS

D171,251 S 1/1954 Courtney

1 Claim, 5 Drawing Sheets

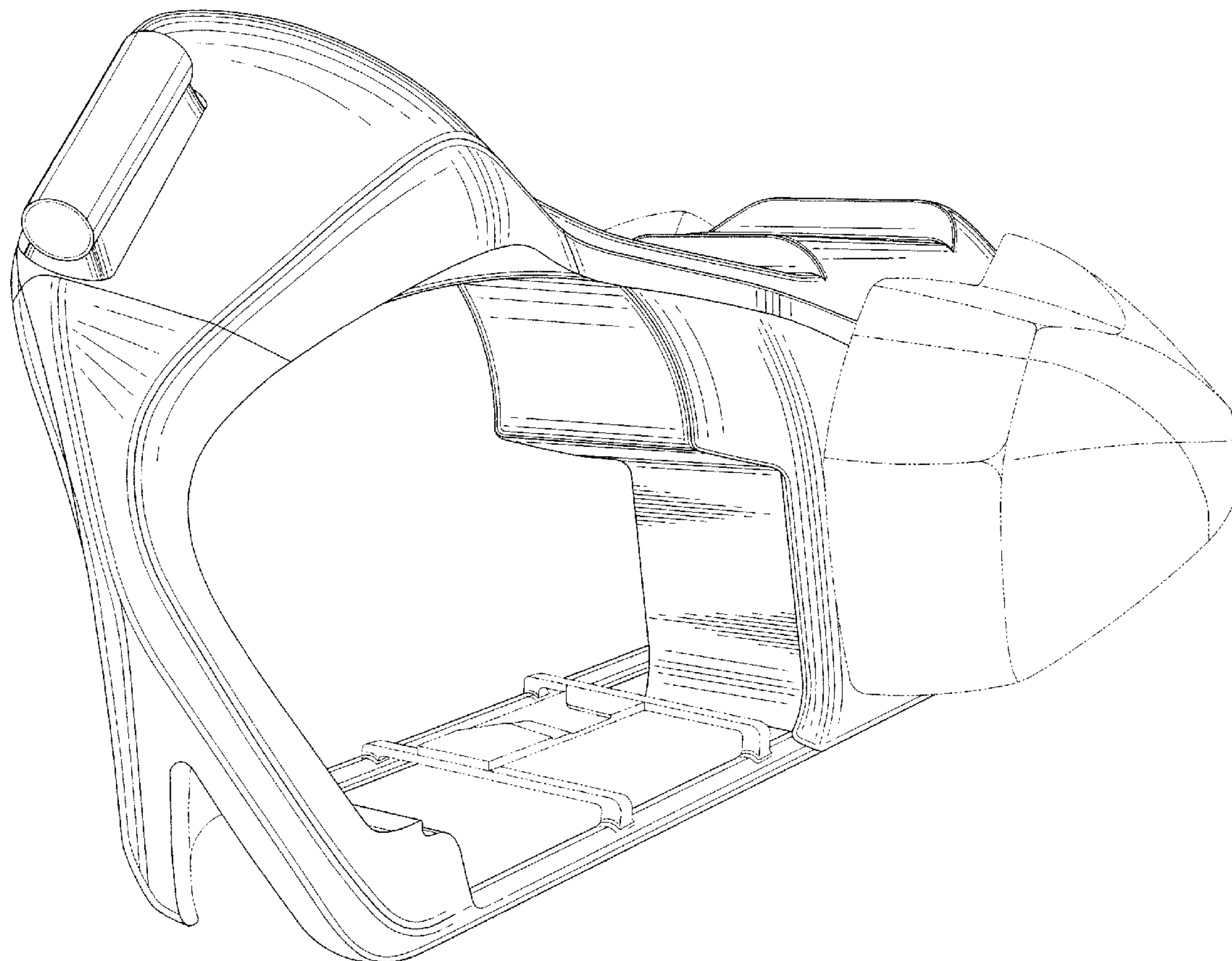

FIG. 1

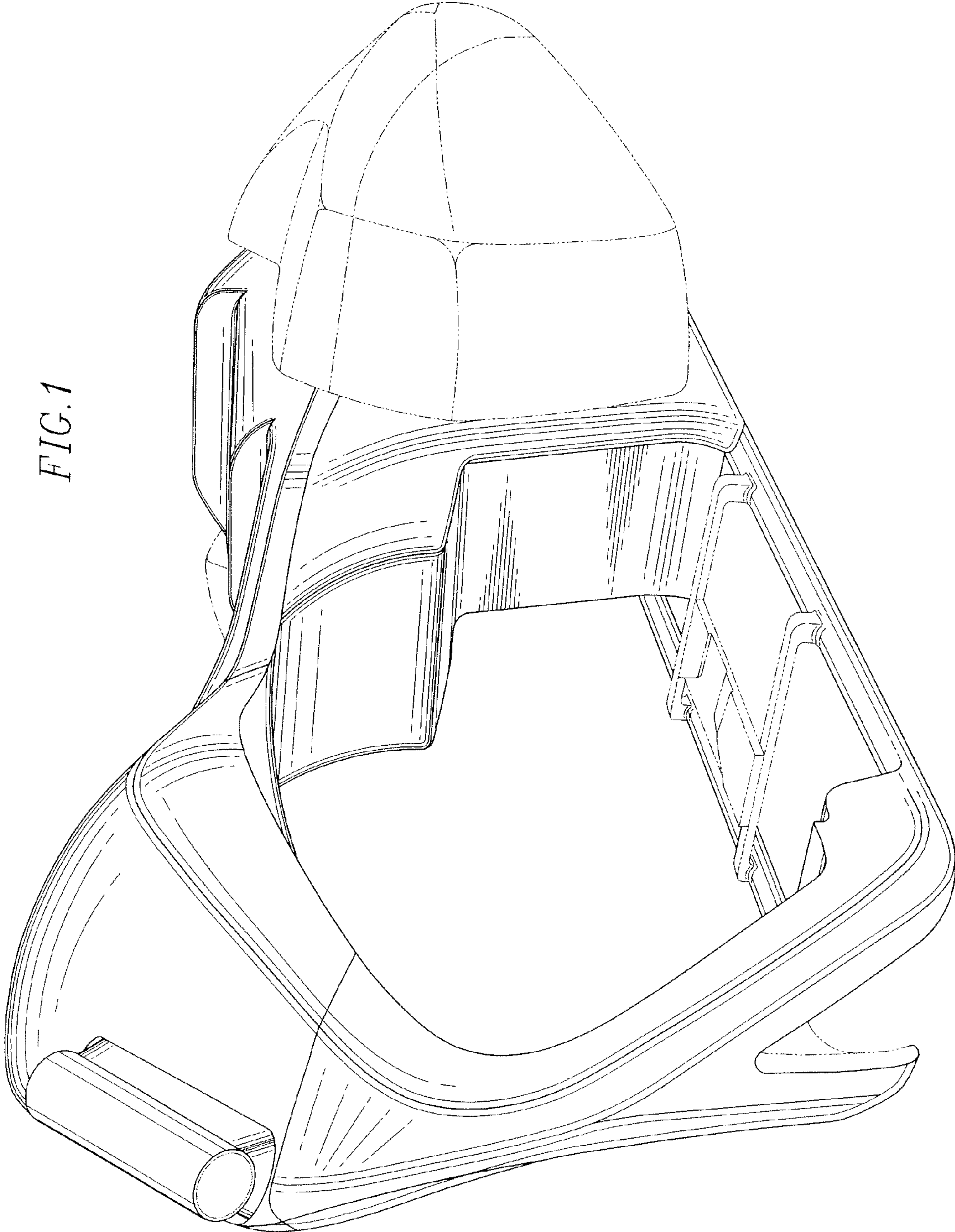

FIG. 2

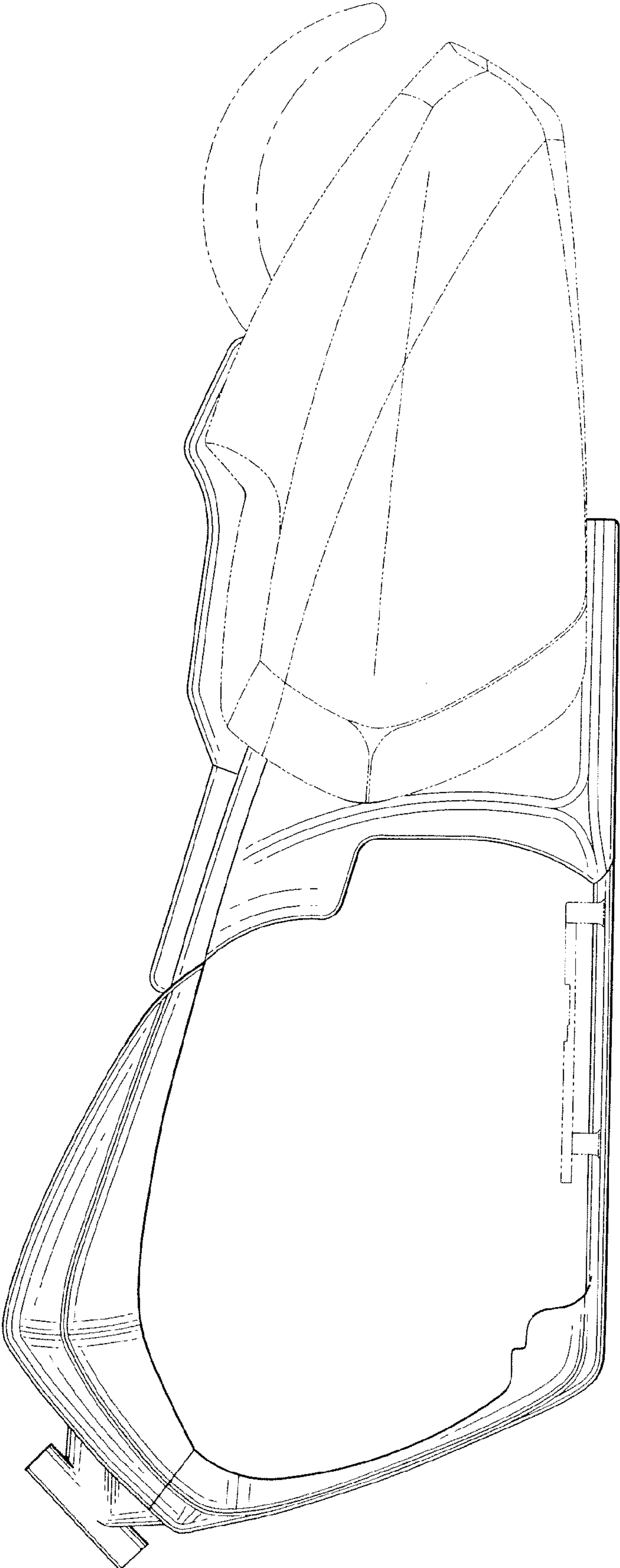

FIG. 3

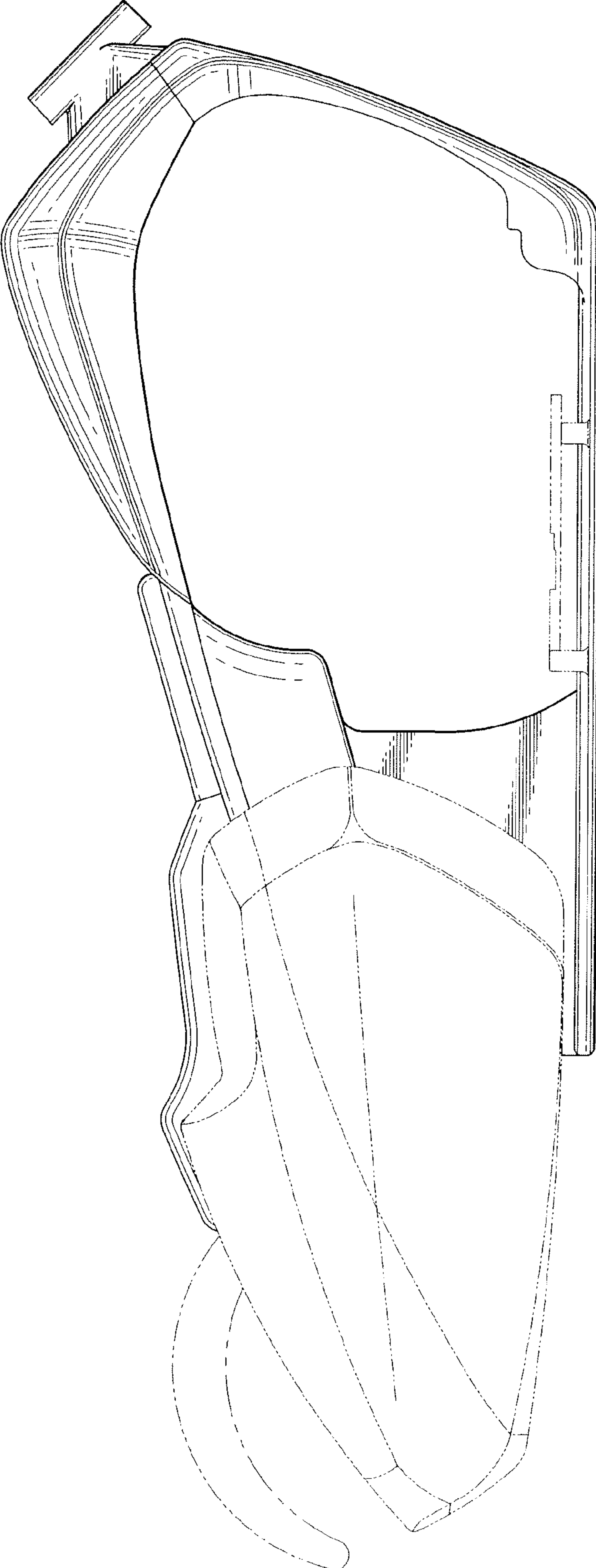

FIG. 4

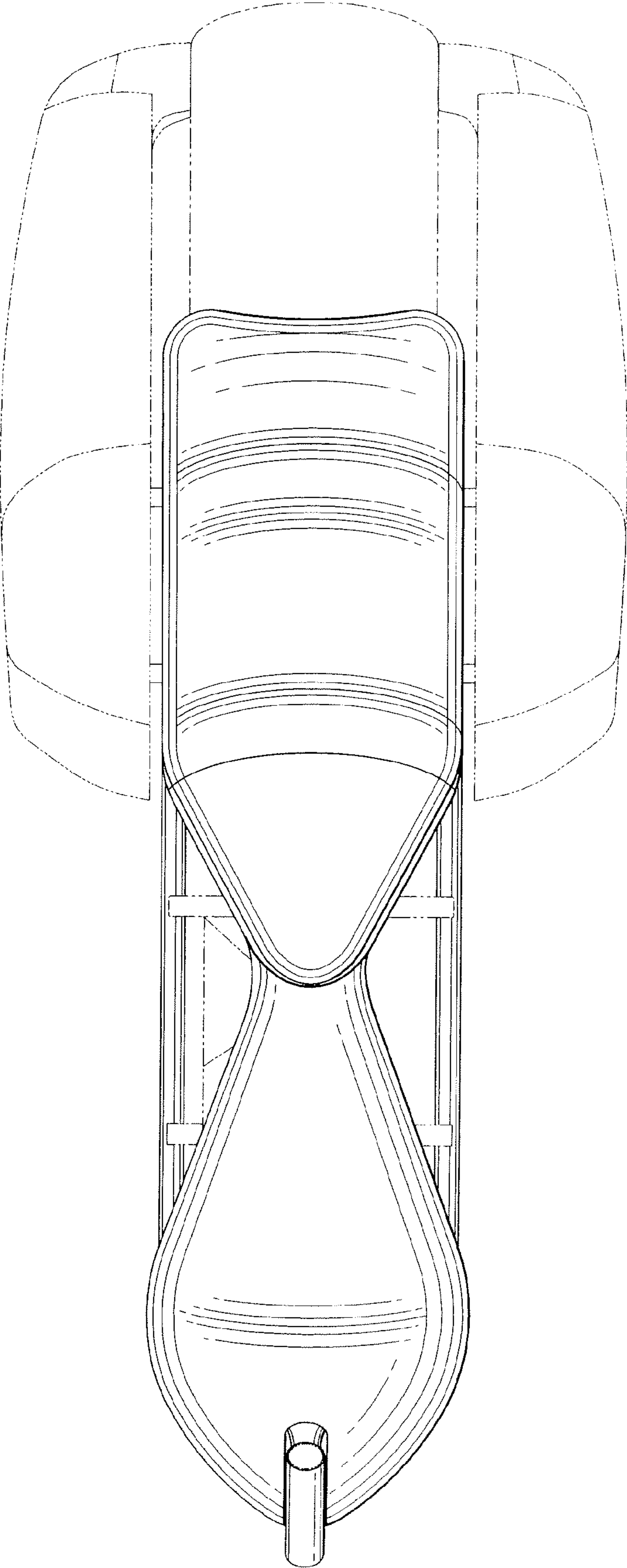

FIG. 6

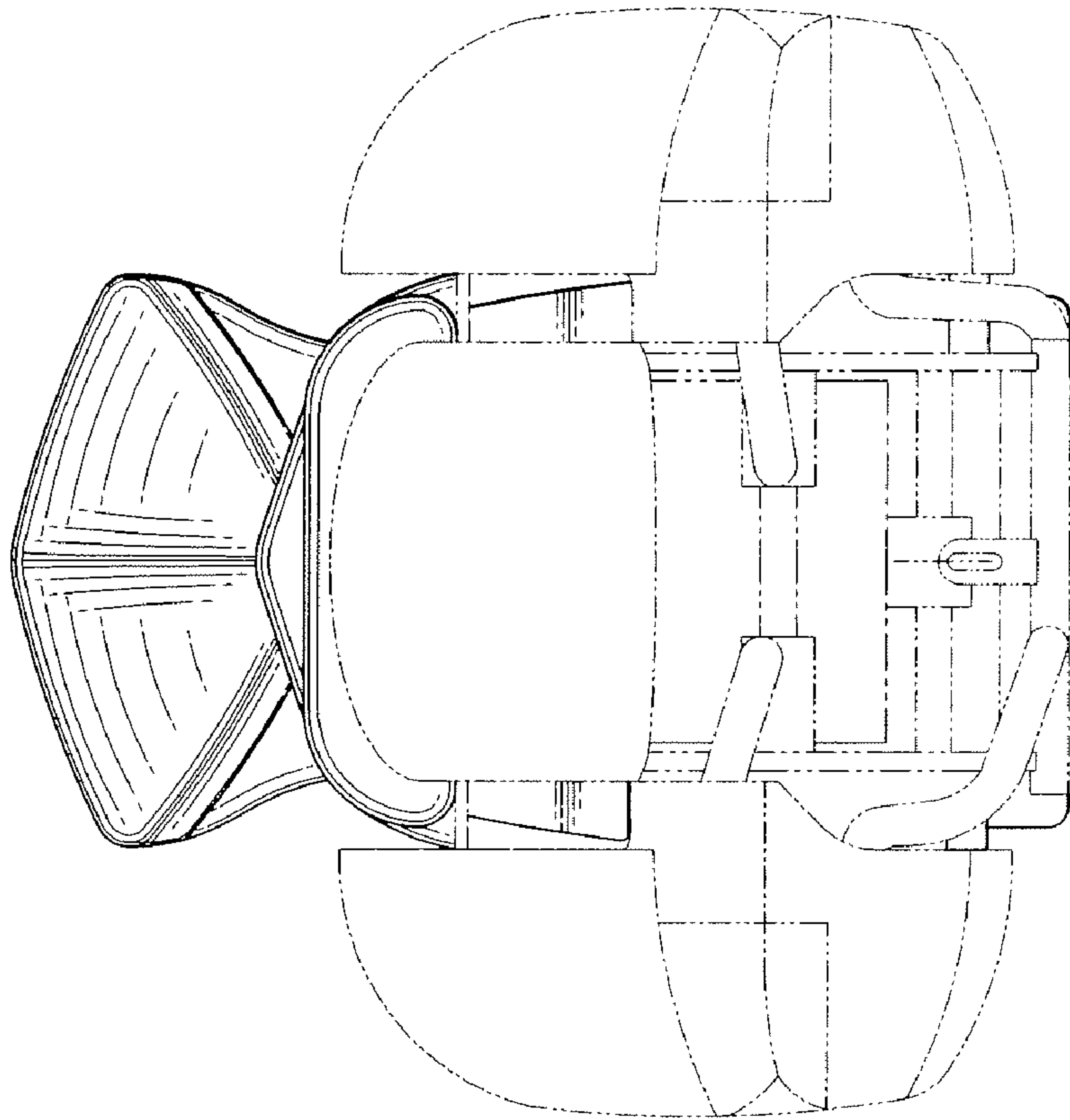

FIG. 5

