



US00D564884S

(12) **United States Design Patent**  
**Rittman**

(10) **Patent No.:** **US D564,884 S**  
(45) **Date of Patent:** **\*\* Mar. 25, 2008**

(54) **BOTTLE**

(75) Inventor: **Gerd Rittman**, Karlsruhe (DE)

(73) Assignee: **Nobel Biocare Services AG**, Flughafen (CH)

(\*\*) Term: **14 Years**

(21) Appl. No.: **29/277,369**

(22) Filed: **Feb. 22, 2007**

**Related U.S. Application Data**

(62) Division of application No. 29/207,764, filed on Jun. 17, 2004, now Pat. No. Des. 538,165.

(51) **LOC (8) Cl.** ..... **09-01**

(52) **U.S. Cl.** ..... **D9/522; D9/452**

(58) **Field of Classification Search** ..... D9/434, D9/452, 516, 521-523, 526, 529, 537, 549, D9/454, 551-552, 558, 564-565, 571-575, D9/682, 686-694; 220/660, 669, 675; D3/202  
See application file for complete search history.

(56) **References Cited**

**U.S. PATENT DOCUMENTS**

D51,560 S	12/1917	Reizenstein	
D205,736 S	9/1966	Jordan	
3,285,450 A	11/1966	Piker	
D256,885 S *	9/1980	DiScala	..... D9/574
D273,563 S *	4/1984	Jeans et al.	..... D9/522
D284,166 S	6/1986	Buchholz et al.	
D285,535 S	9/1986	Buchholz et al.	
D314,334 S	2/1991	Desgrippes	
D359,453 S	6/1995	Gavin	
D362,624 S	9/1995	Vignot	

D372,872 S	8/1996	Crawford	
D388,331 S *	12/1997	Haner et al.	..... D9/571
D413,269 S	8/1999	Hebert	
D443,980 S	6/2001	Stewart	
D467,808 S	12/2002	Hagemann et al.	
D480,975 S	10/2003	de Baschmakoff	
D487,702 S *	3/2004	Sironi	..... D9/558
D503,621 S	4/2005	Heater	
D506,391 S *	6/2005	Busch et al.	..... D9/522
D516,433 S	3/2006	De Aguiar	
D518,730 S	4/2006	Caserta et al.	

\* cited by examiner

*Primary Examiner*—Ian Simmons

*Assistant Examiner*—Anna Burmeister

(74) *Attorney, Agent, or Firm*—Knobbe, Martens, Olson & Bear, LLP.

(57) **CLAIM**

The ornamental design for a bottle, as shown and described.

**DESCRIPTION**

FIG. 1 is a top, front, left side perspective view of a bottle embodying my new design;

FIG. 2 is a top, rear, left side perspective view thereof;

FIG. 3 is a front elevational view thereof;

FIG. 4 is a right side elevational view, the left side elevational view being a mirror image thereof;

FIG. 5 is a top plan view thereof; and,

FIG. 6 is a bottom, front, left side perspective view thereof.

The broken lines shown in the drawings represent contour lines.

**1 Claim, 6 Drawing Sheets**

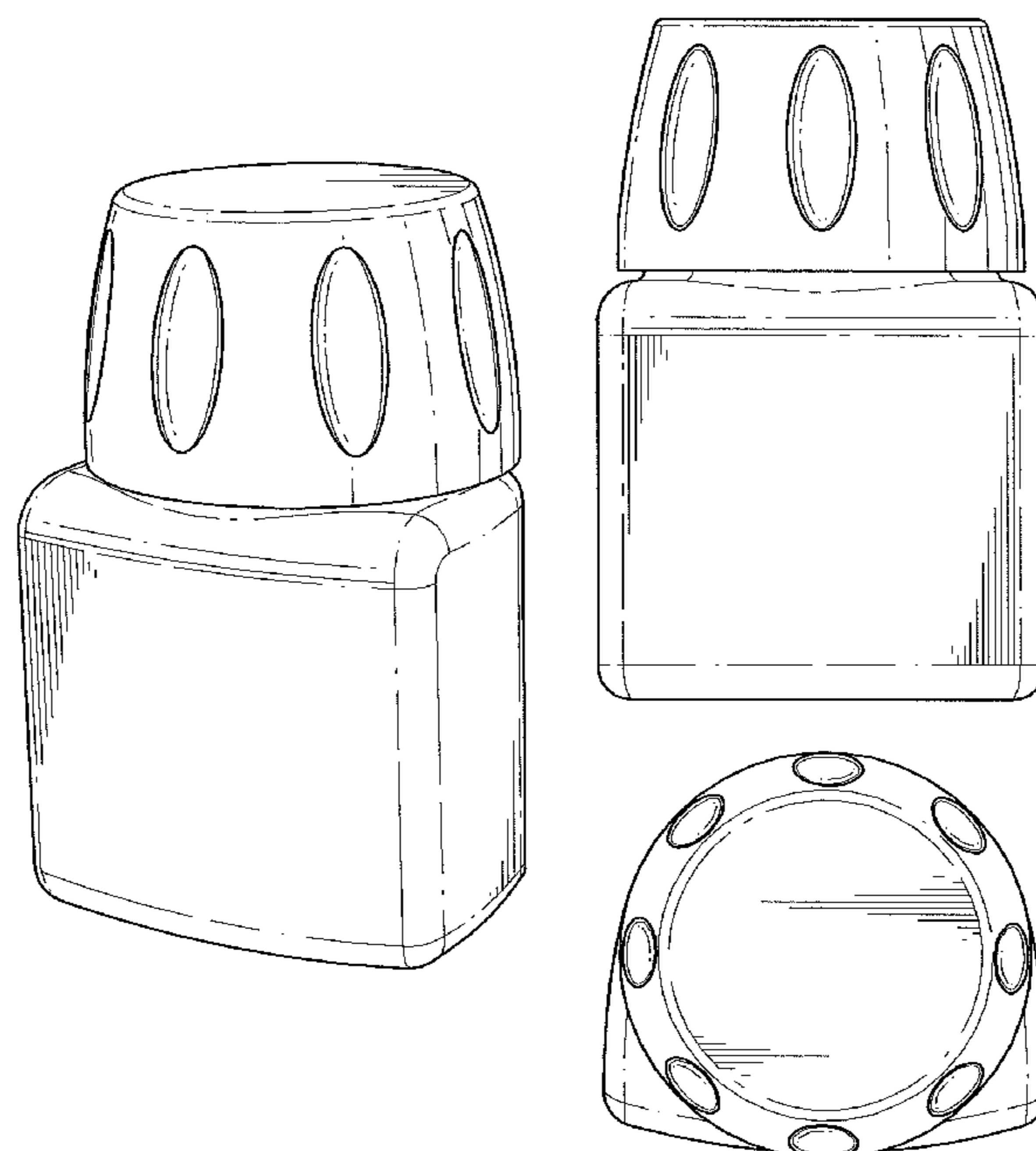

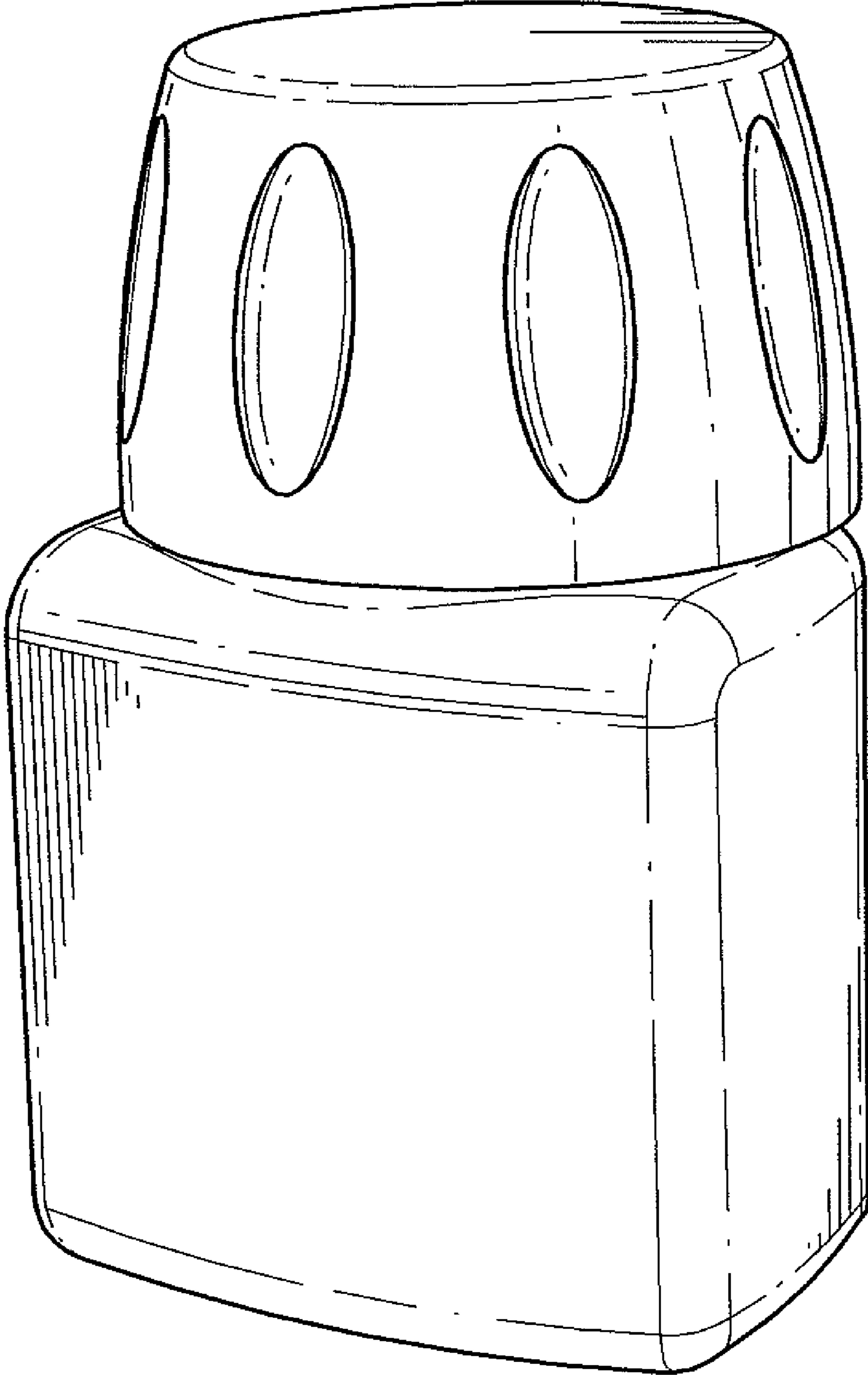

*FIG. 1*

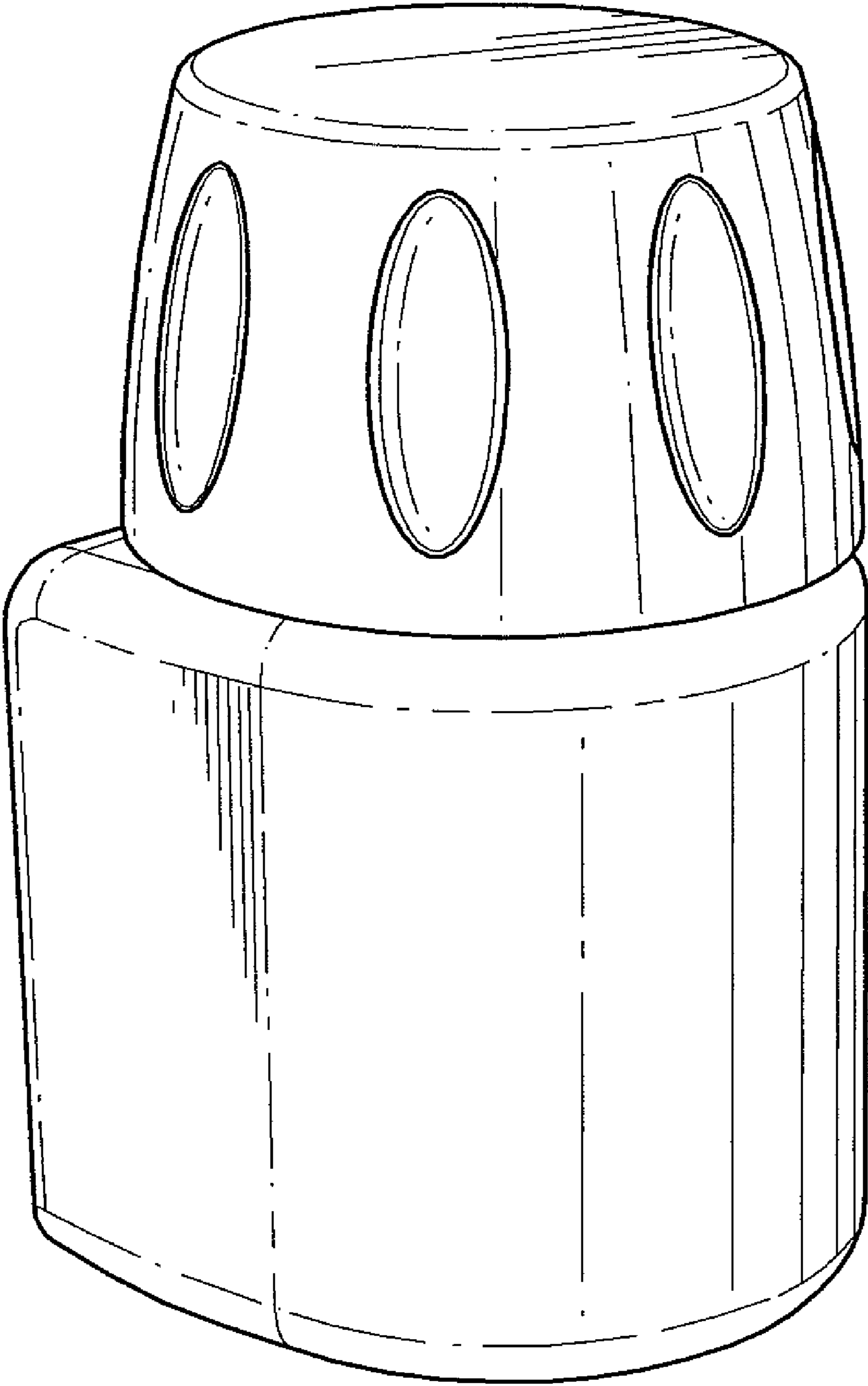
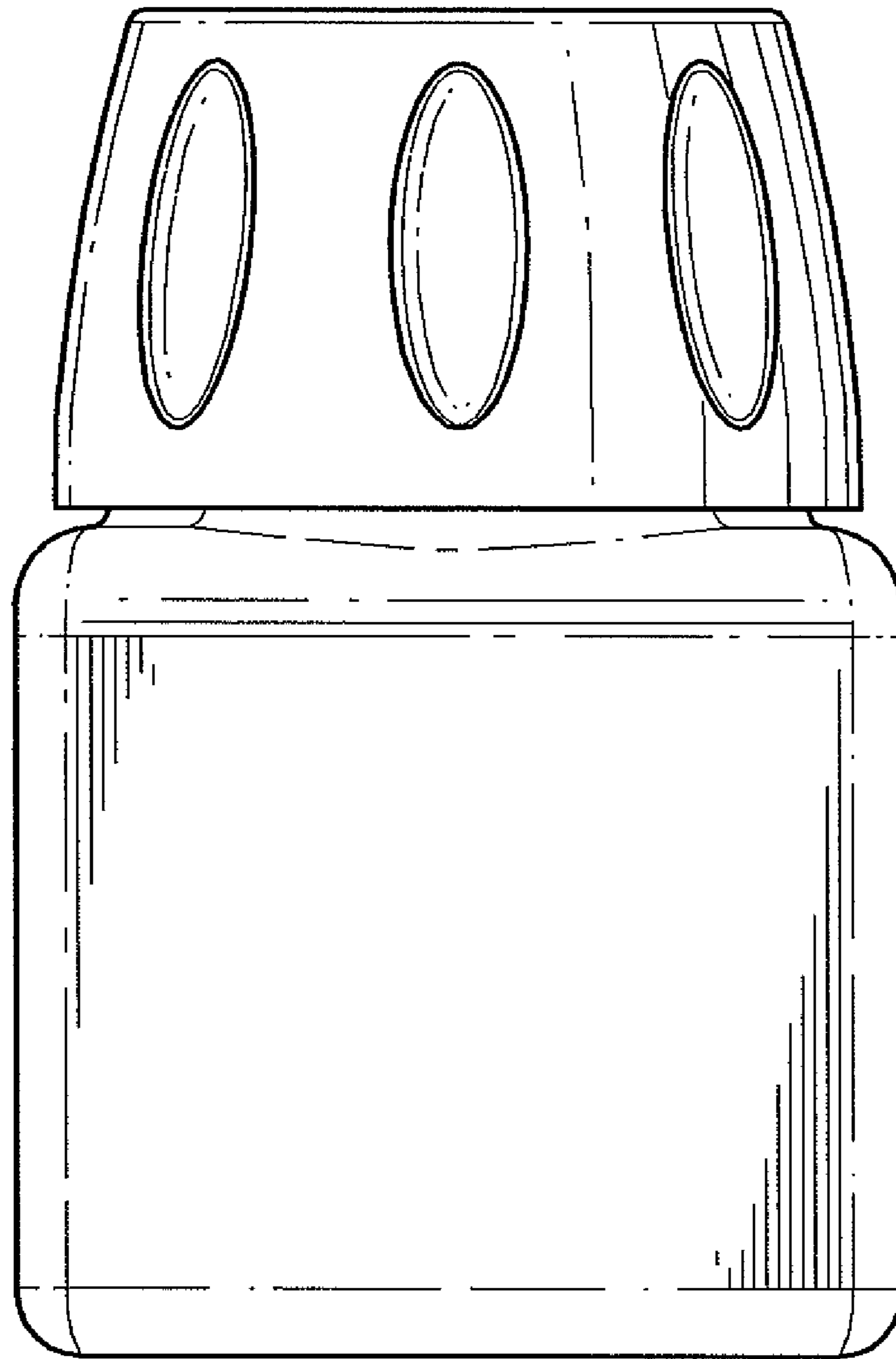

FIG. 2



*FIG. 3*

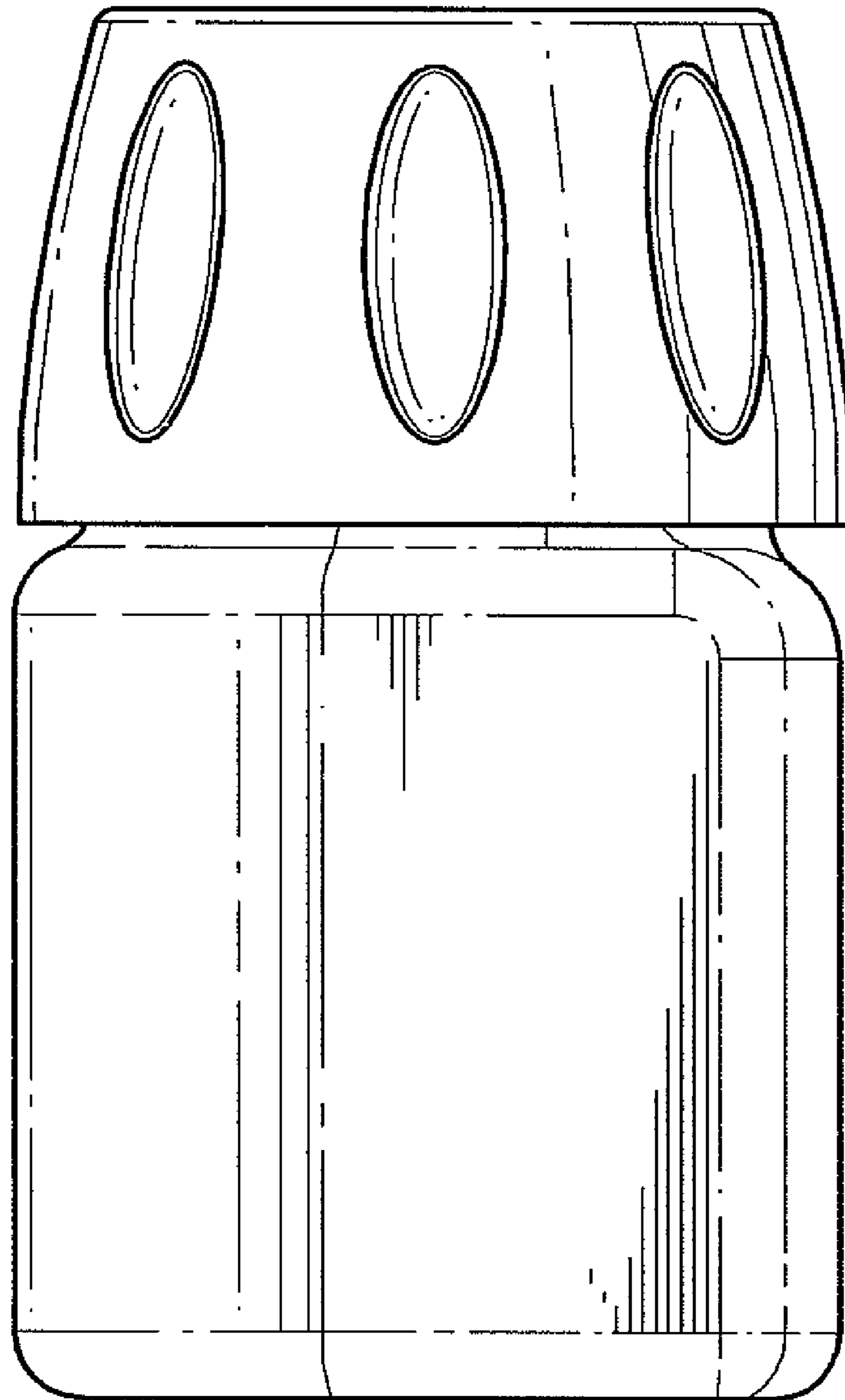
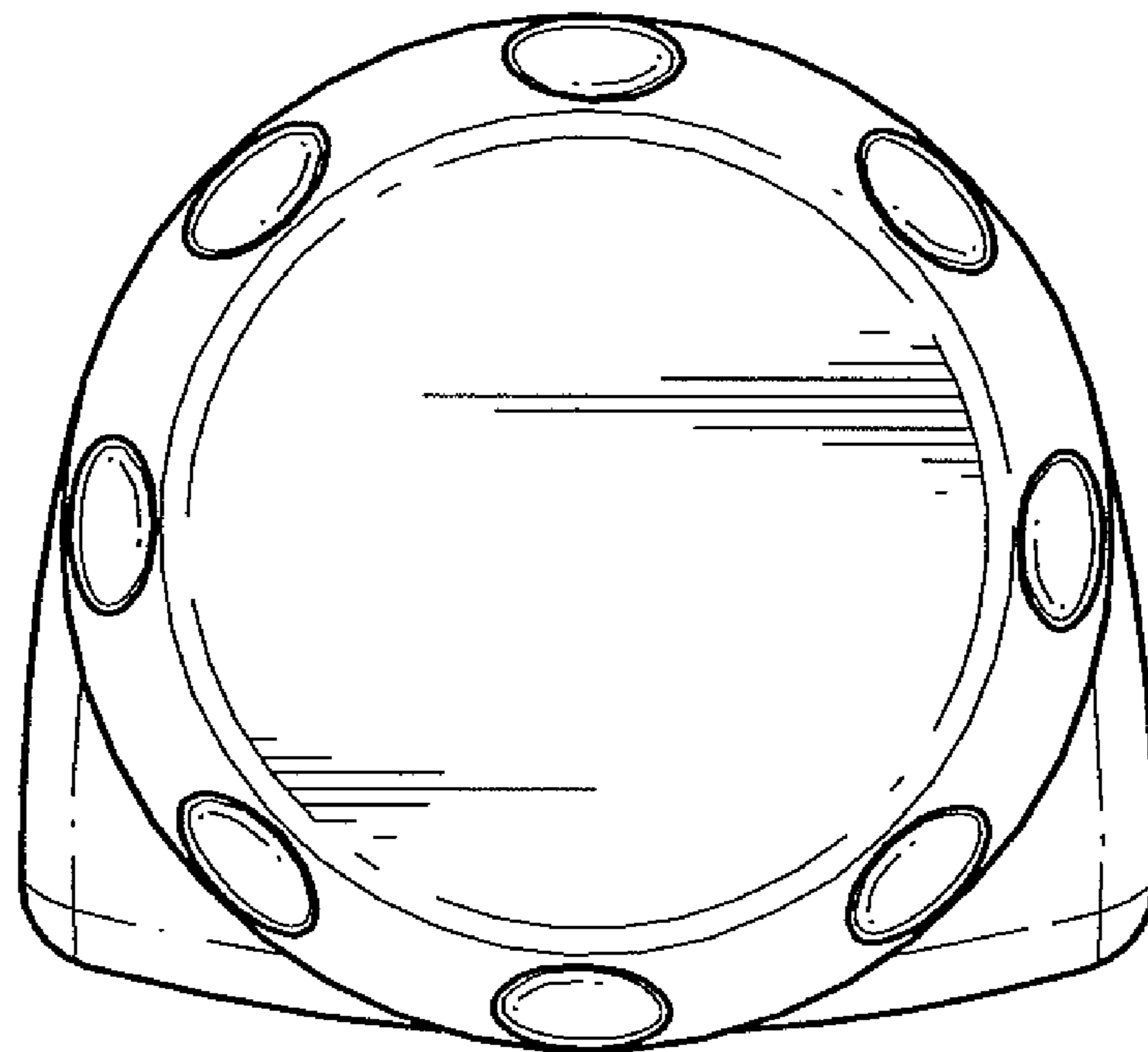
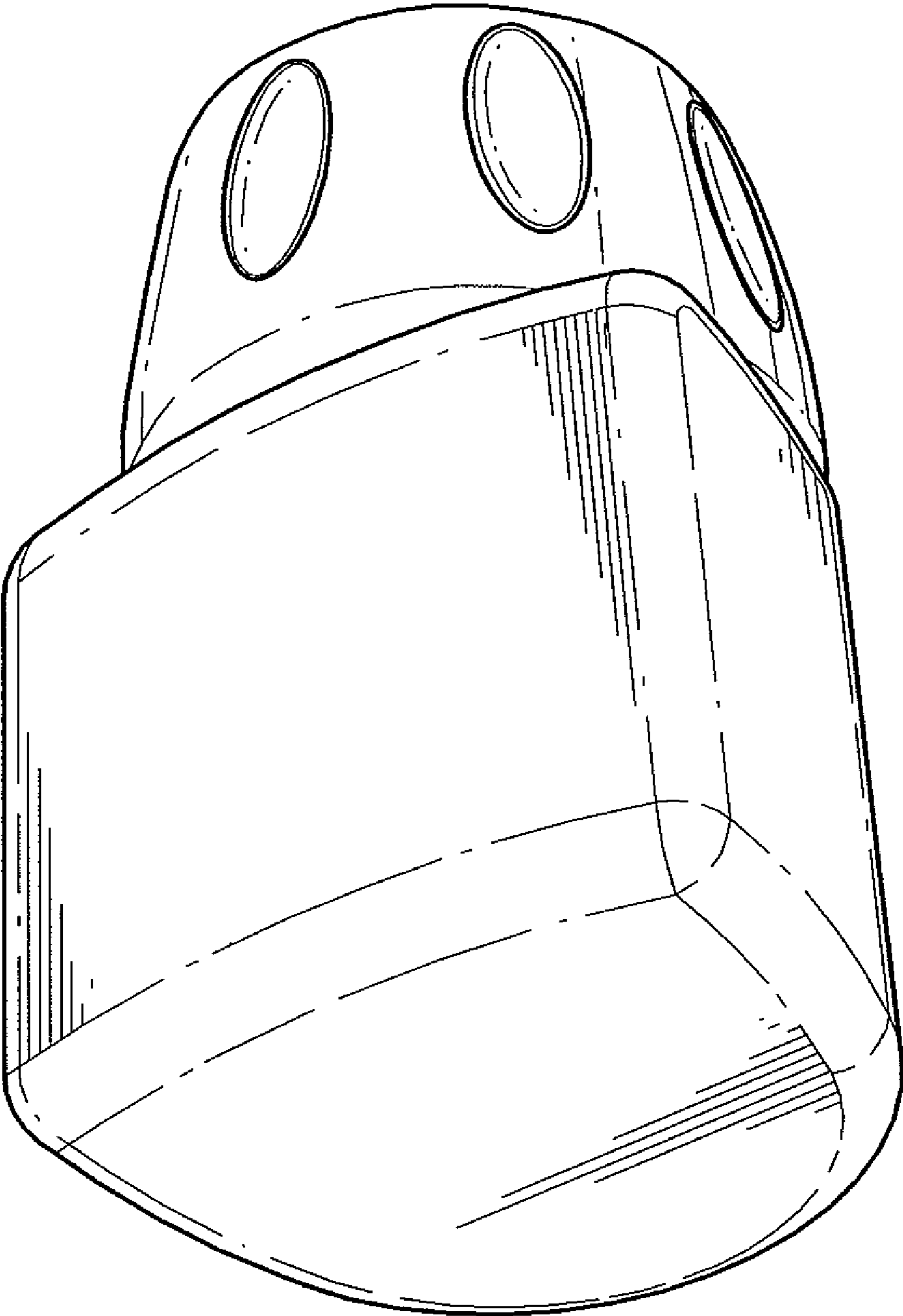

FIG. 4



*FIG. 5*



*FIG. 6*