

US00D564755S

(12) **United States Design Patent** (10) **Patent No.:** **US D564,755 S**  
**Sellers et al.** (45) **Date of Patent:** **\*\* Mar. 25, 2008**

(54) **SKI EQUIPMENT TRANSPORT APPARATUS**

(76) Inventors: **David R. Sellers**, 3305 County Road 96, Ward, CO (US) 80481; **Deanna L. Griffith**, 149 Muerdago Rd., Topanga, CA (US) 90290; **Etienne Iliffe-Moon**, 1248 N. Crescent Heights Blvd., Apartment #2, Los Angeles, CA (US) 90046; **Daniel W. Ashcraft**, 4733 Darien St., Torrance, CA (US) 90503

(\*\*) Term: **14 Years**

(21) Appl. No.: **29/241,422**

(22) Filed: **Oct. 27, 2005**

(51) **LOC (8) Cl.** ..... **03-01**

(52) **U.S. Cl.** ..... **D3/261**

(58) **Field of Classification Search** ..... D3/254,  
D3/261, 315; 224/917; 280/814, 47.18,  
280/35, 809; D34/12, 24; 206/315.1

See application file for complete search history.

(56) **References Cited**

**U.S. PATENT DOCUMENTS**

4,114,915 A	9/1978	Lello et al.	
4,268,050 A	5/1981	Kennedy, Sr.	
4,358,137 A	11/1982	Gramm	
4,666,184 A *	5/1987	Garvey, Jr.	280/814
4,856,811 A	8/1989	Bressler et al.	
5,106,112 A	4/1992	Sargent	
D332,695 S *	1/1993	Moscovitch	D3/261
5,240,285 A	8/1993	Harris	
5,277,449 A	1/1994	Schmidt	
5,340,153 A *	8/1994	Parker	280/814
D392,801 S *	3/1998	Hields et al.	D3/261
6,070,906 A	6/2000	Allen	
6,086,102 A	7/2000	Stark et al.	
6,848,718 B2	2/2005	Ravikumar et al.	

\* cited by examiner

*Primary Examiner*—Philip S. Hyder  
(74) *Attorney, Agent, or Firm*—Daniel P. Dooley; Fellers, Snider, et al.

(57) **CLAIM**

The ornamental design for a ski equipment transport apparatus, as shown and described.

**DESCRIPTION**

FIG. 1 is a top right side perspective of a ski equipment transport apparatus showing my new design, wherein the broken line showing of the alpine skis and poles are included for the purpose of illustrating environmental structure and form no part of the claimed design.

FIG. 2 is a top right side perspective of the new inventive ski equipment transport apparatus of FIG. 1, showing both a ski equipment confinement portion confined within a transport caddy, and a security lock communicating with the transport caddy and combined for storage, wherein the broken line showing of the security lock is included for the purpose of illustrating environmental structure and form no part of the claimed design.

FIG. 3 is a top plan view of transport caddy portion of the new inventive ski equipment transport apparatus of FIG. 2.

FIG. 4 is a top right side perspective of the ski equipment confinement portion of the new inventive ski equipment transport apparatus of FIG. 2.

FIG. 5 is a bottom plan view of the ski equipment confinement portion of FIG. 4; and,

FIG. 6 is an elevational end view of the ski equipment confinement portion of FIG. 4.

The alpine skis and poles along with the security lock shown in broken lines are provided for environment purposes only and form no part of the claimed design.

The broken line portions of FIG. 5 form no part of the claimed design.

**1 Claim, 5 Drawing Sheets**

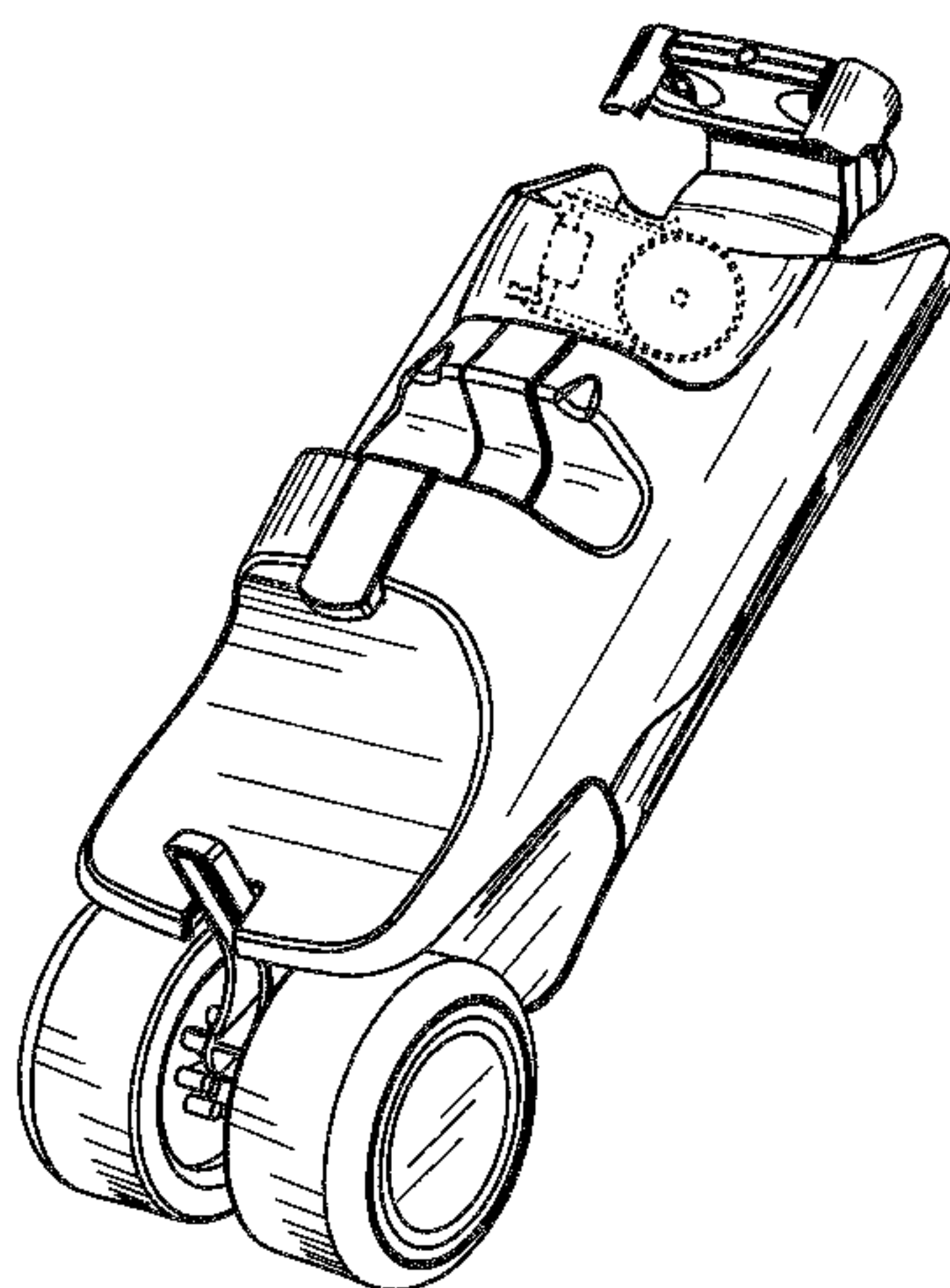

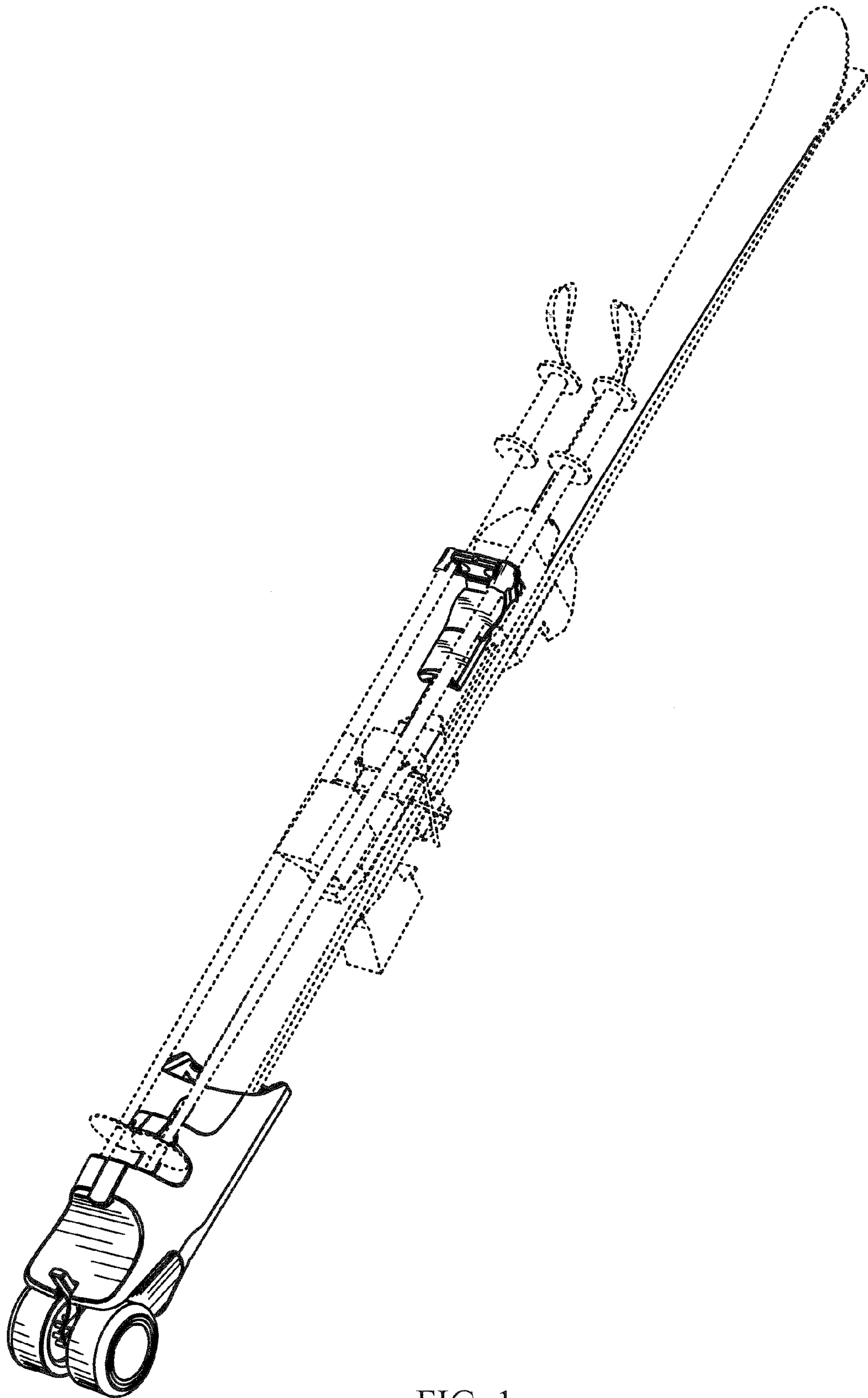

FIG. 1

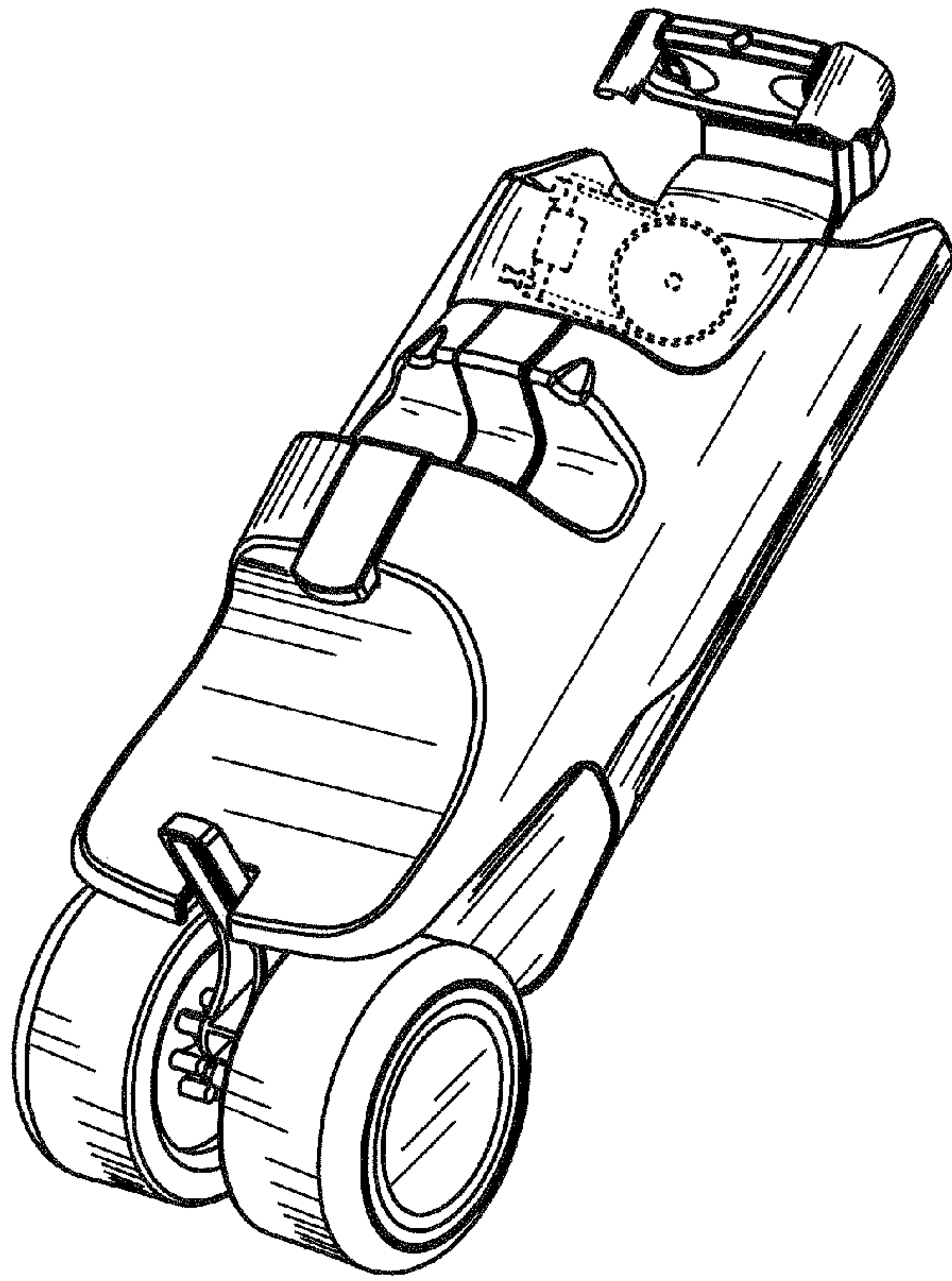

FIG. 2

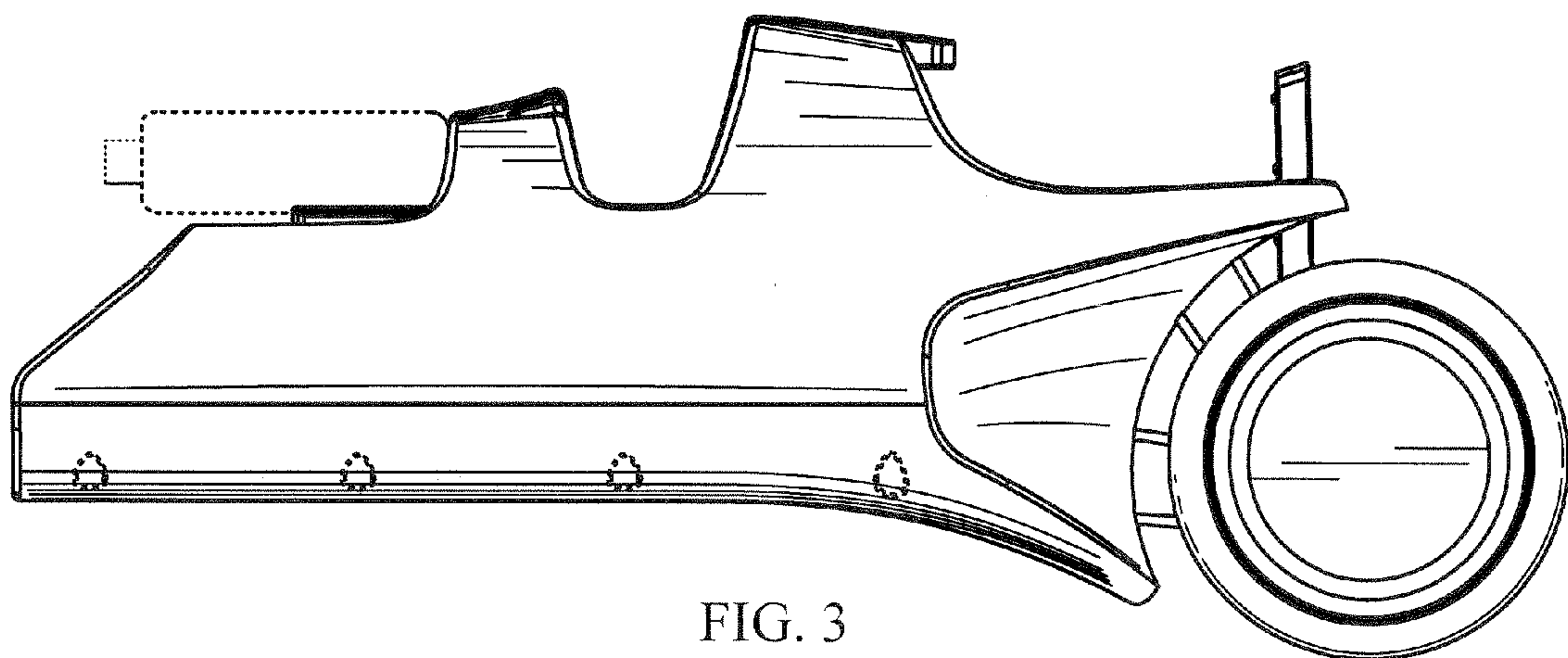

FIG. 3



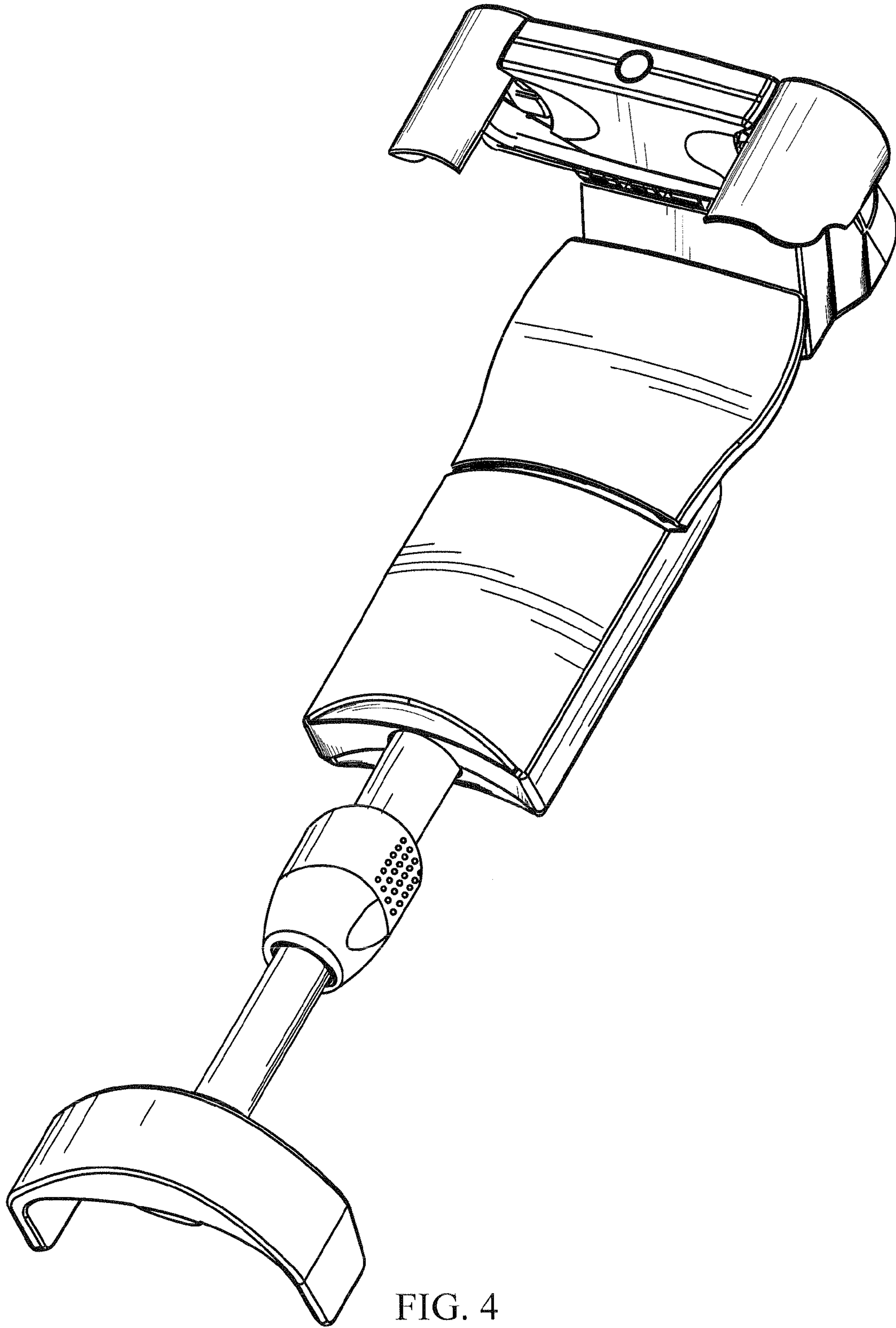

FIG. 4

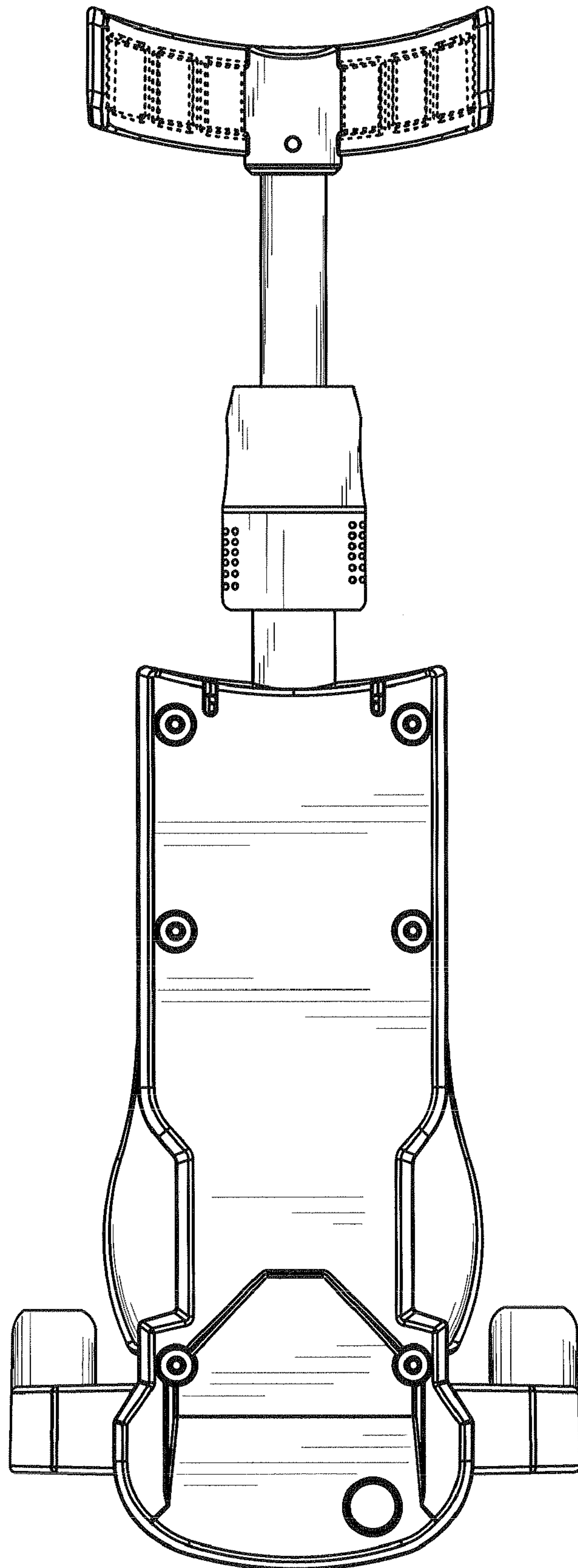

FIG. 5

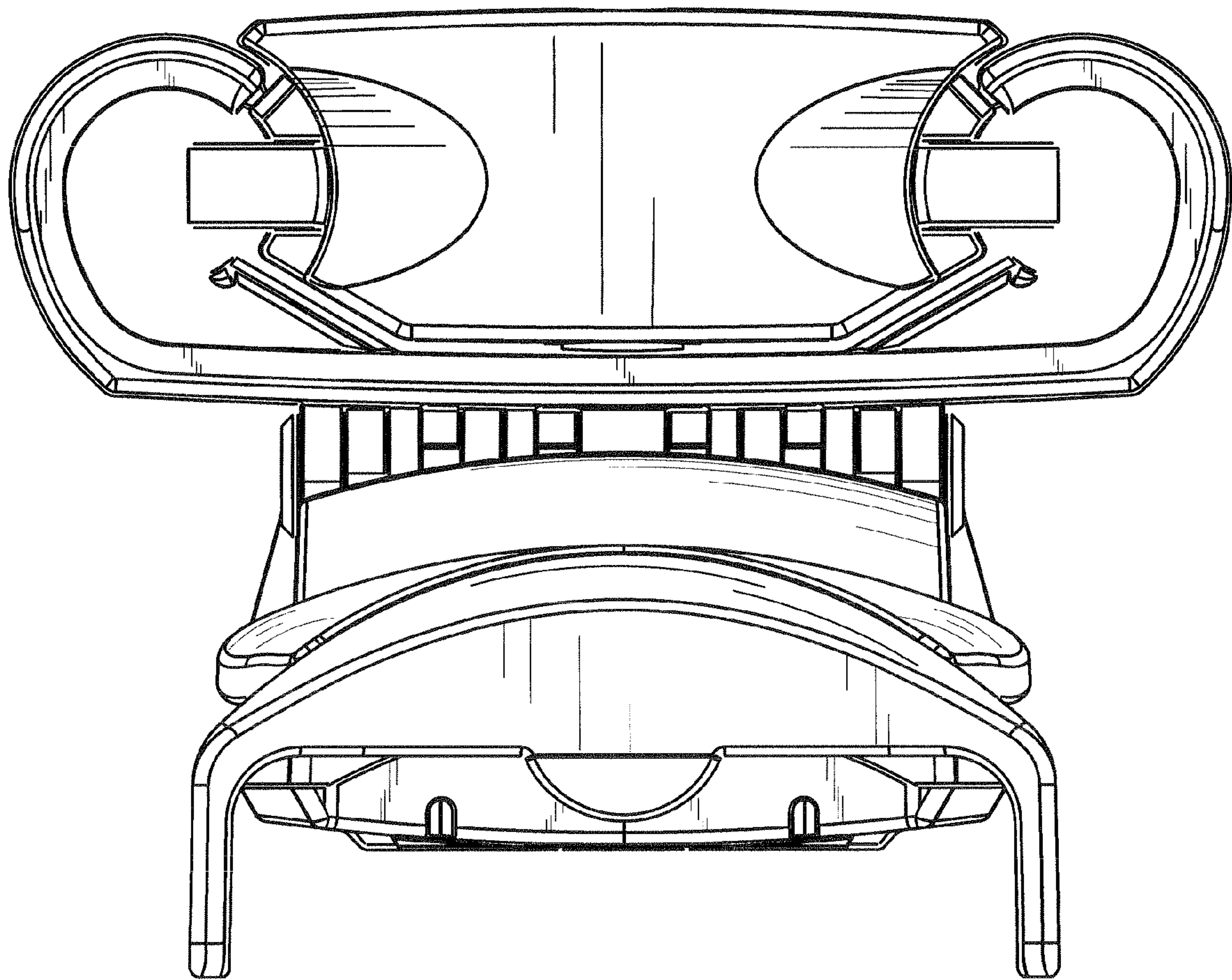

FIG. 6