



US00D564683S

(12) **United States Design Patent**  
**Roach et al.**

(10) **Patent No.: US D564,683 S**  
(45) **Date of Patent: \*\* \*Mar. 18, 2008**

(54) **AUXILIARY HEADLAMP FOR MOTOR VEHICLES**

(75) Inventors: **Alan R. Roach**, Escondido, CA (US);  
**Stephen J. Mitchell**, Aguanga, CA (US)

(73) Assignee: **Baja Designs, Inc.**, San Marcos, CA (US)

D304,621 S	11/1989	Schmidt	
D304,622 S	11/1989	Schmidt	
D304,861 S	11/1989	Schmidt	
D383,227 S	9/1997	Nagano	
D393,086 S	3/1998	Nagano	
D490,172 S	* 5/2004	Yamamoto	..... D26/28
D495,814 S	9/2004	James	
D513,599 S	* 1/2006	Coward	..... D10/120
D514,973 S	* 2/2006	Coward	..... D10/120
D520,656 S	* 5/2006	Shiu	..... D26/28

(\*) Notice: This patent is subject to a terminal disclaimer.

\* cited by examiner

(\*\*) Term: **14 Years**

*Primary Examiner*—Marcus A. Jackson

(74) *Attorney, Agent, or Firm*—James E Curry

(21) Appl. No.: **29/255,278**

(57) **CLAIM**

(22) Filed: **Mar. 7, 2006**

We claim the ornamental design for auxiliary headlamp for motor vehicles, as shown and described.

(51) **LOC (8) Cl.** ..... **26-06**

(52) **U.S. Cl.** ..... **D26/28**

(58) **Field of Classification Search** ..... D26/28-36;  
362/459-468, 475-478, 485-487

See application file for complete search history.

**DESCRIPTION**

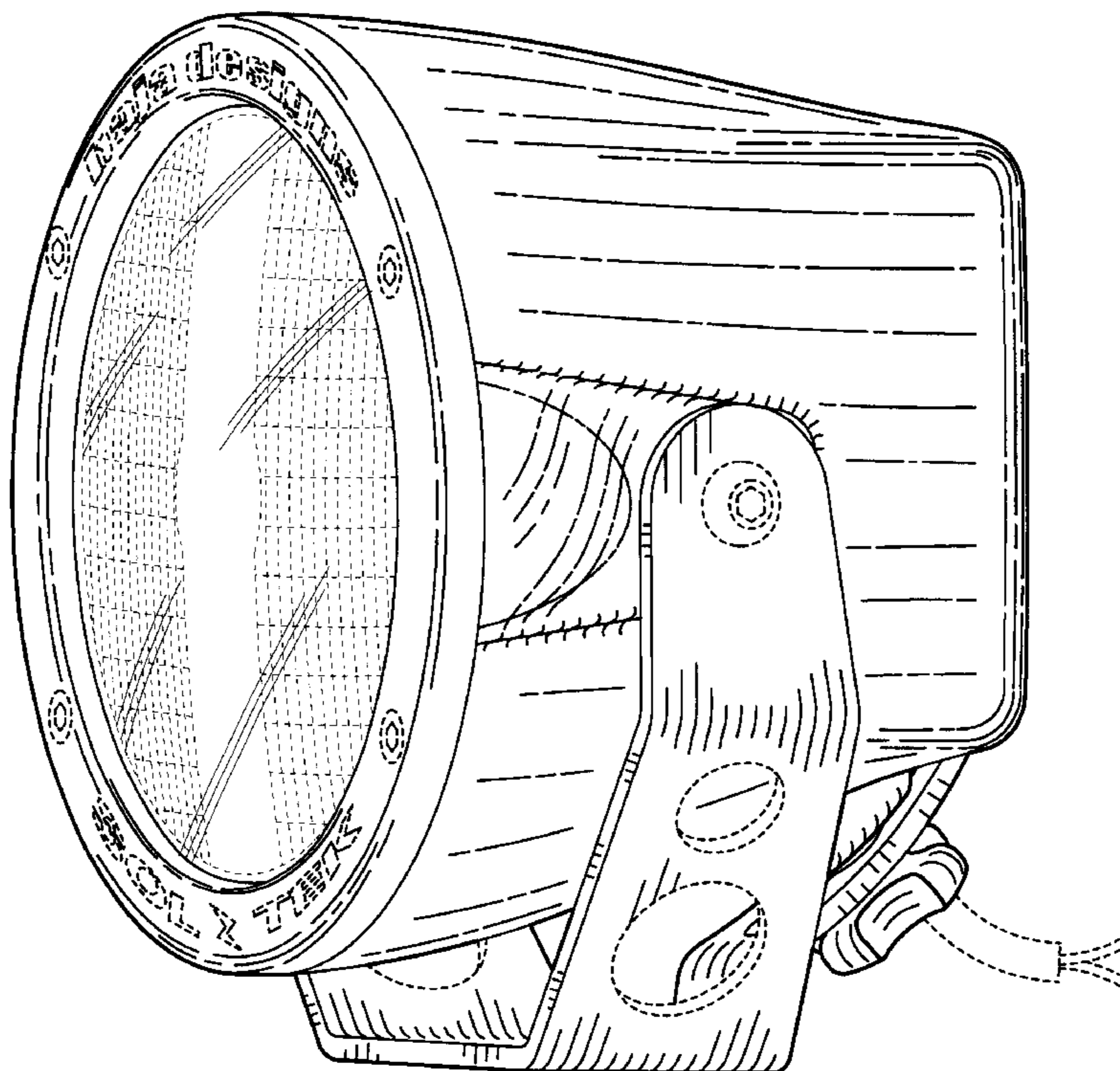
FIG. 1 is a front elevation view of an auxiliary headlamp for motor vehicles showing our new design;  
FIG. 2 is a top plan view thereof;  
FIG. 3 is a bottom plan view thereof;  
FIG. 4 is a right elevation view thereof;  
FIG. 5 is a left elevation view thereof;  
FIG. 6 is a back elevation view thereof; and,  
FIG. 7 is a front-right perspective view thereof.  
Structure that is not part of the claimed design is shown in broken lines in the figures.

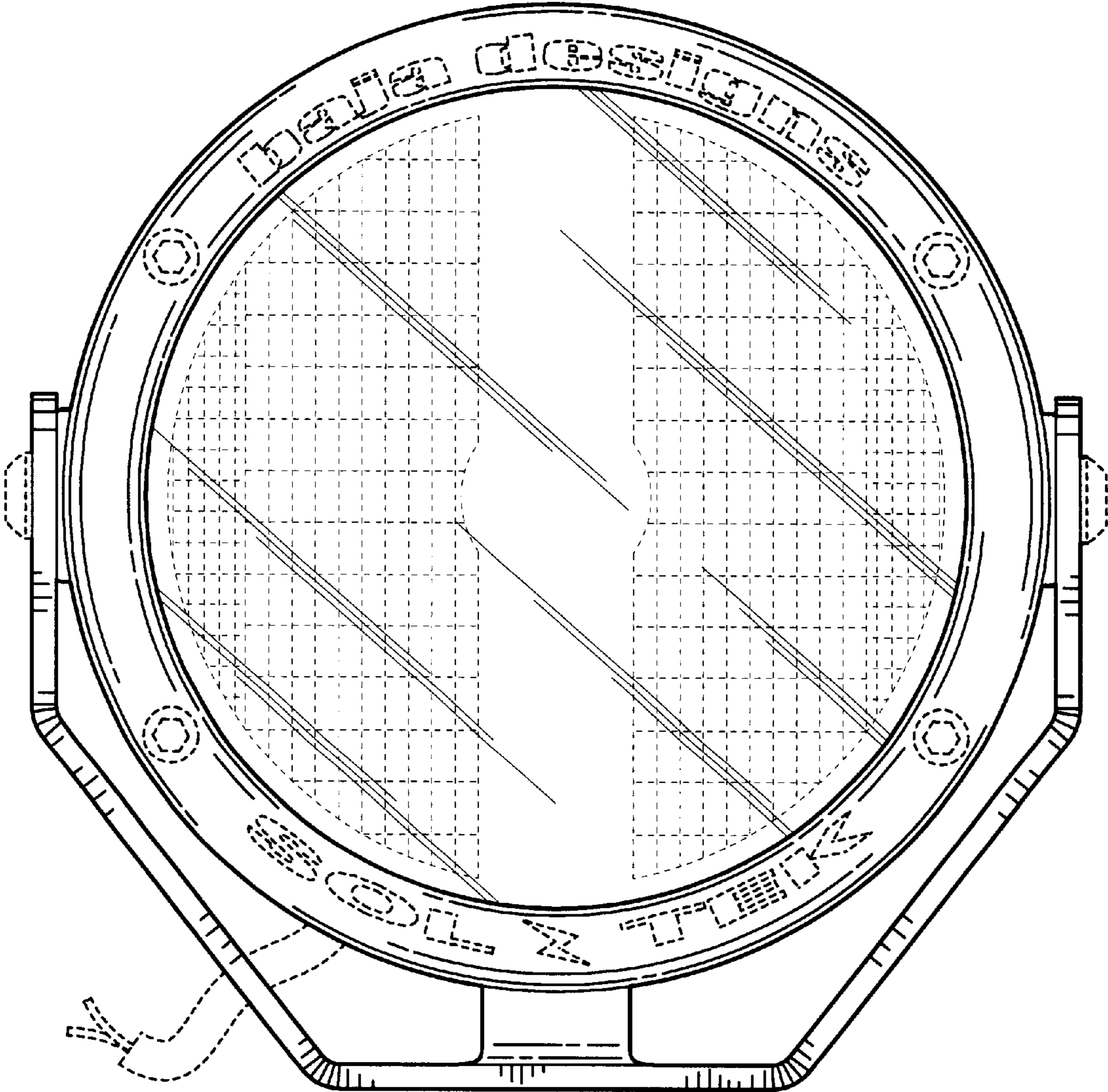
(56) **References Cited**

**U.S. PATENT DOCUMENTS**

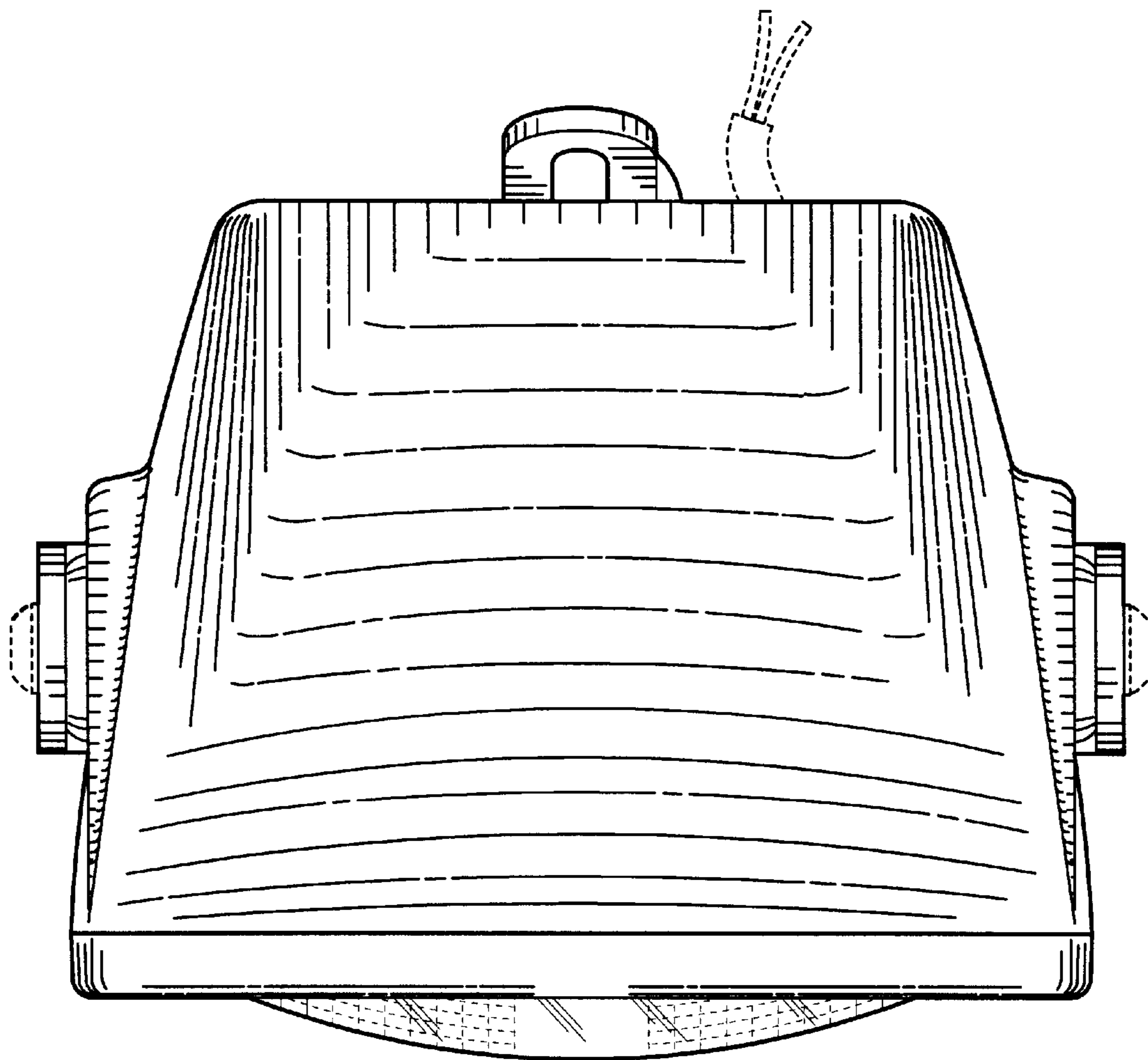
D248,691 S	7/1978	Cibie
D259,516 S	6/1981	Catte
D261,051 S	9/1981	Catte
D266,599 S	10/1982	Suzuki
D274,000 S	5/1984	Bailly
D304,380 S	10/1989	Bailly

**1 Claim, 7 Drawing Sheets**

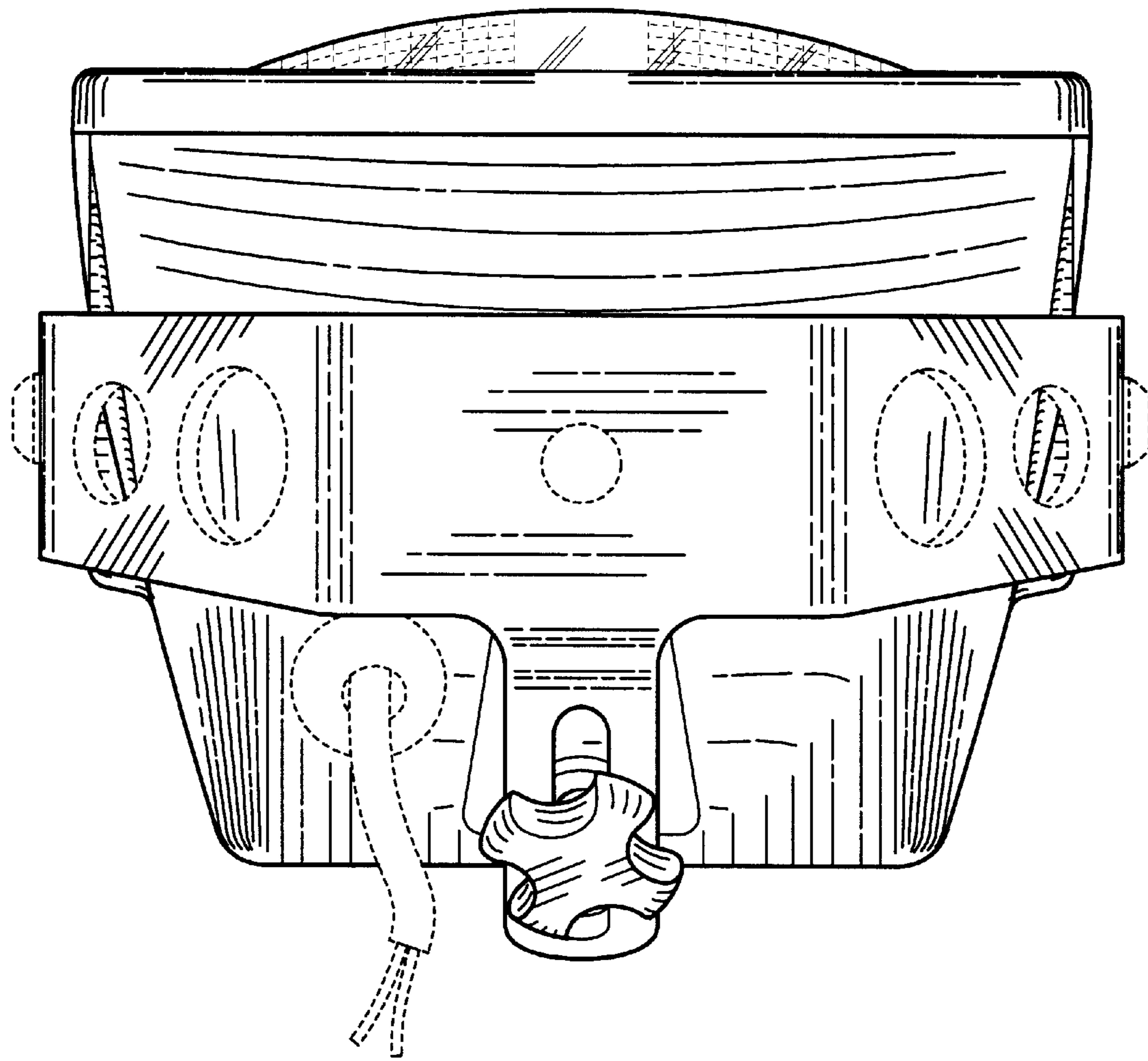




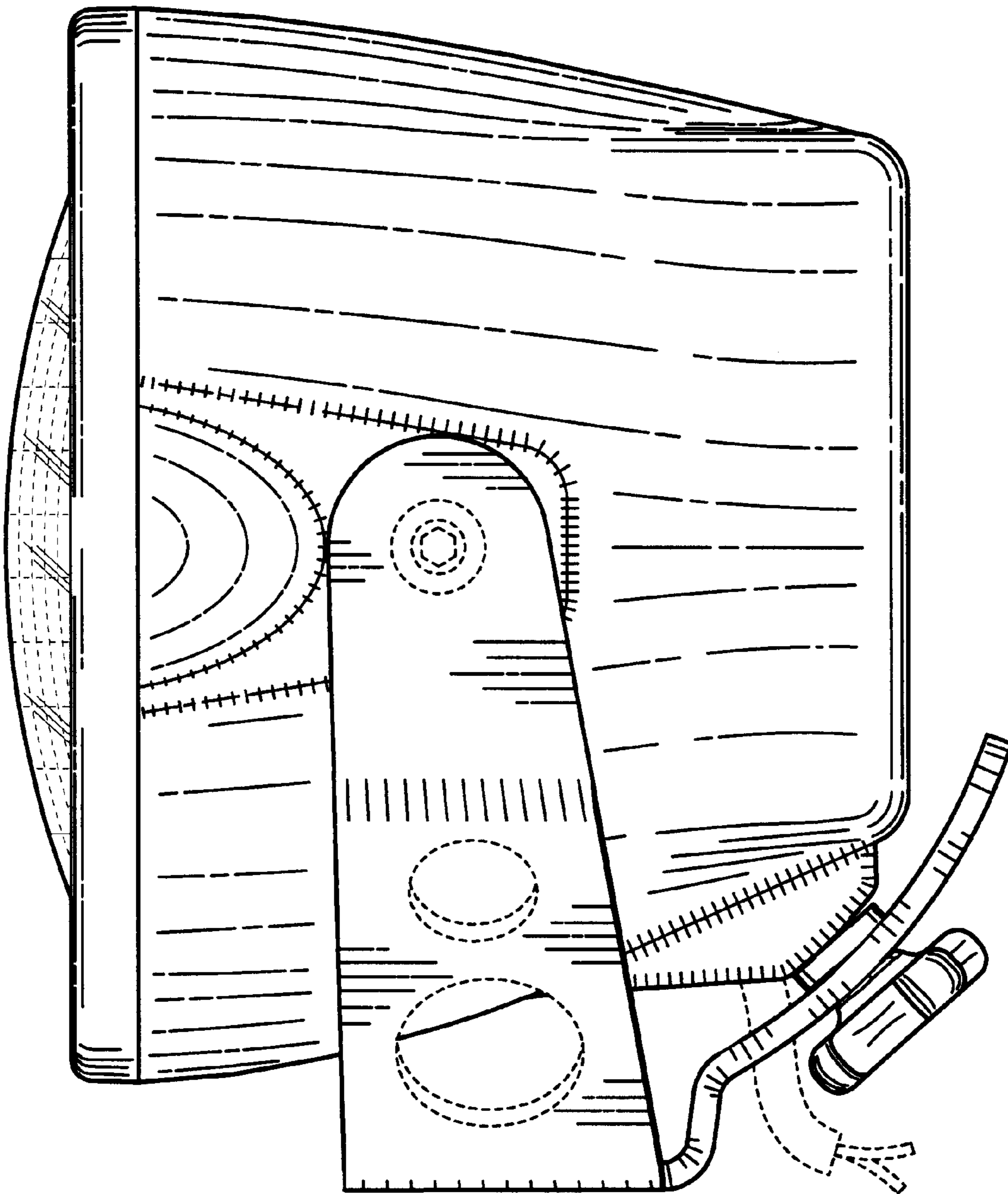
*Fig. 1*



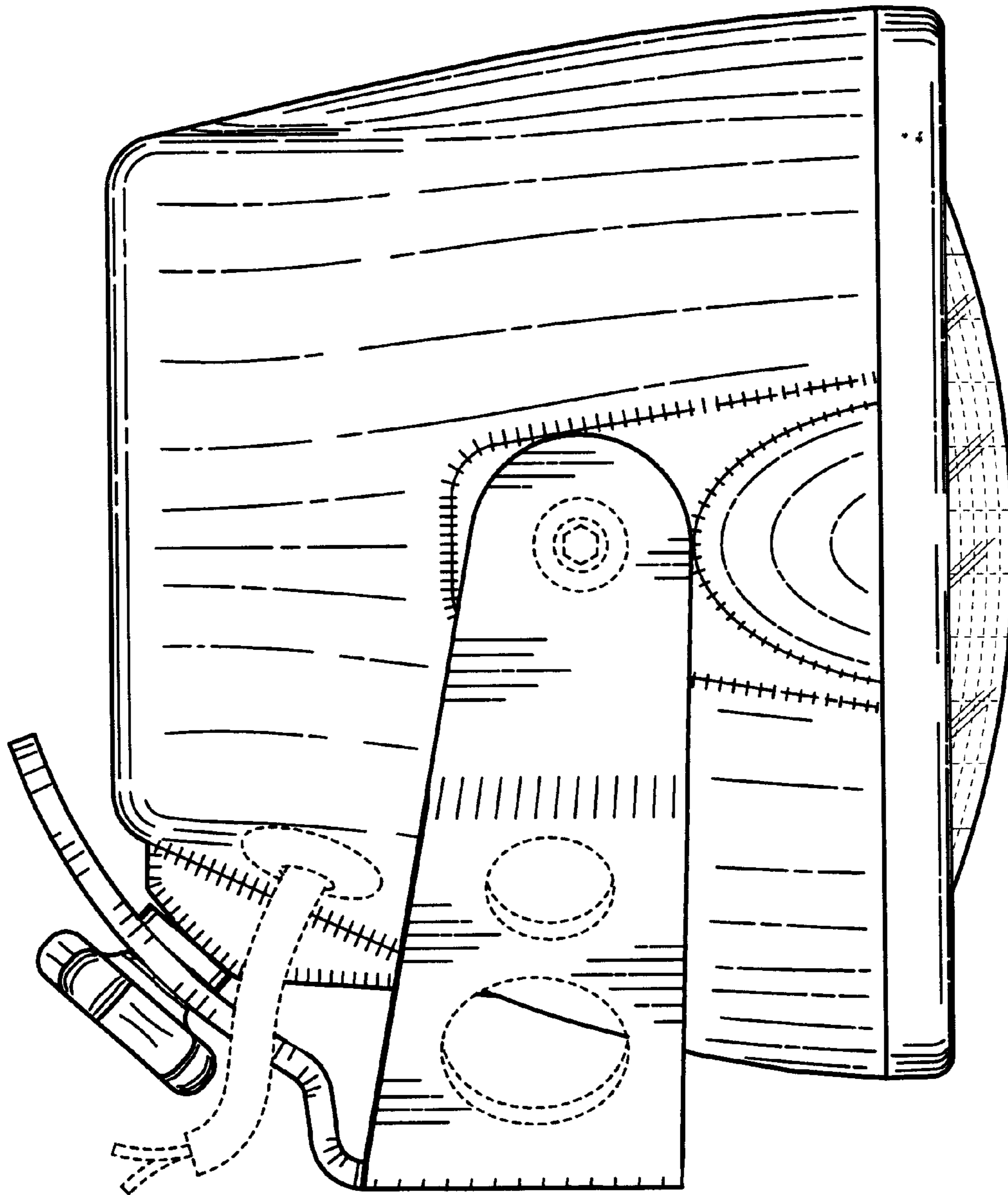
*Fig. 2*



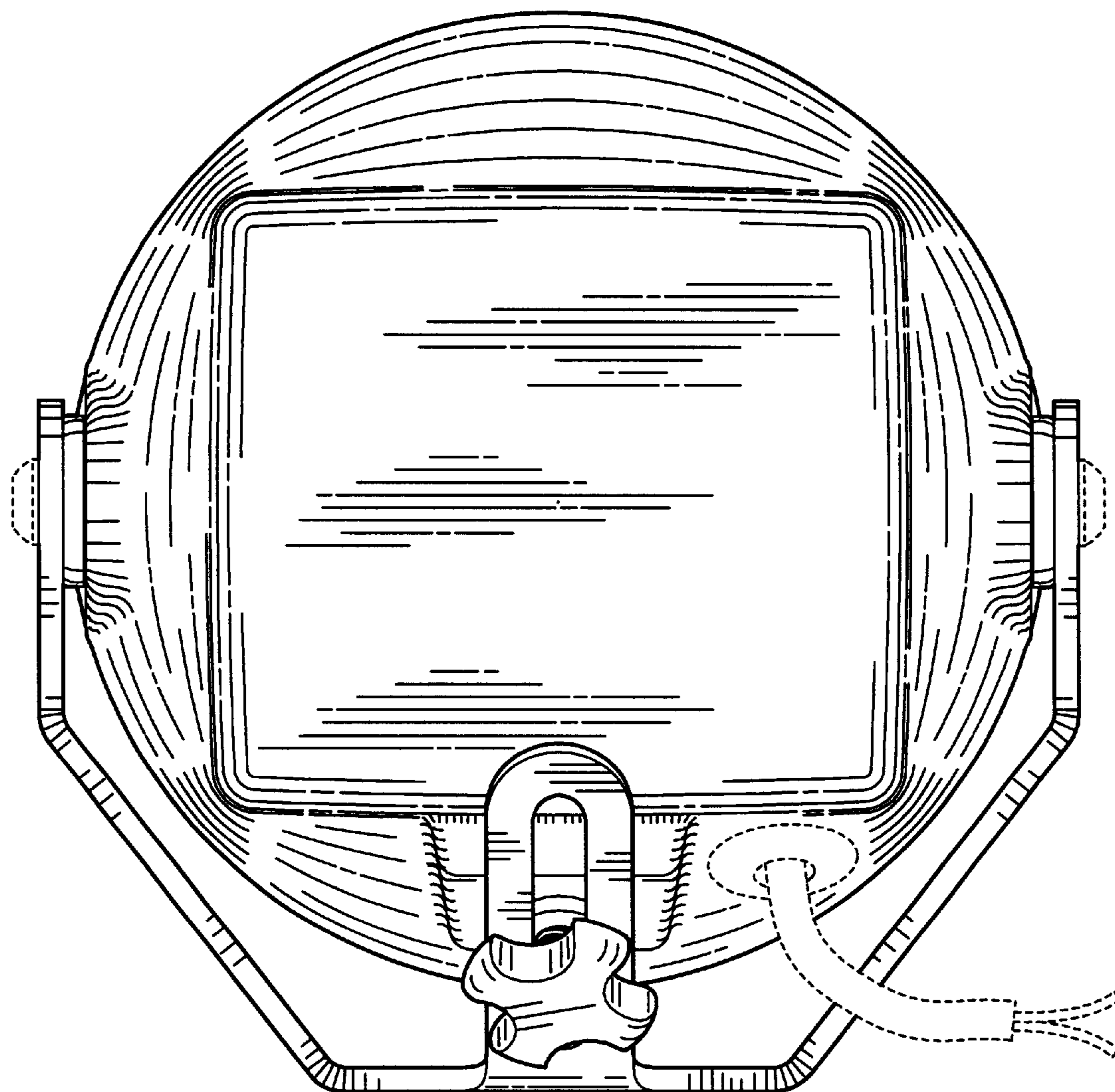
*Fig. 3*



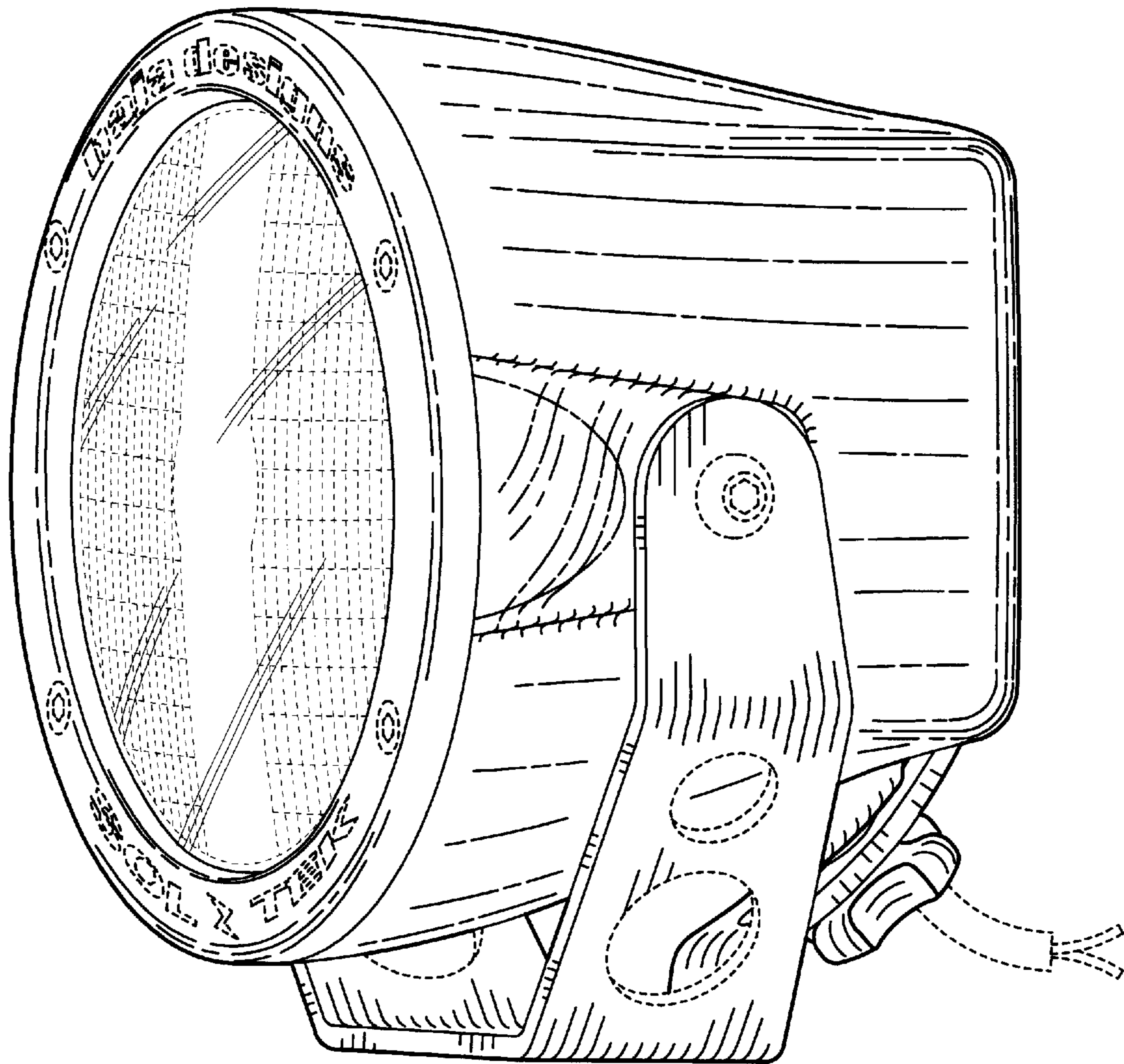
*Fig. 4*



*Fig. 5*



*Fig. 6*



*Fig. 7*