



US00D564595S

(12) **United States Design Patent**
Barrett

(10) **Patent No.:** **US D564,595 S**

(45) **Date of Patent:** **** Mar. 18, 2008**

(54) **VEHICLE SIGN HAVING BASE AND FLAG**

(76) Inventor: **W. Raymond Barrett**, 77 Progress Pkwy., Maryland Heights, MO (US) 63043

(**) Term: **14 Years**

(21) Appl. No.: **29/248,377**

(22) Filed: **Aug. 11, 2006**

(51) **LOC (8) Cl.** **20-03**

(52) **U.S. Cl.** **D20/29**

(58) **Field of Classification Search** D20/10, D20/12, 13, 17, 19, 21, 29, 39, 41, 99; 40/538, 40/541, 547, 591-593, 600; 283/56, 81; 362/812; D11/165, 166; 345/30, 31; D21/405; 403/349

See application file for complete search history.

(56) **References Cited**

U.S. PATENT DOCUMENTS

2,960,786	A	11/1960	Wagner	
D234,443	S	3/1975	Golub	
D330,686	S	11/1992	Campagna	
D360,229	S *	7/1995	Caulk	D20/41
D376,179	S	12/1996	Cohen	
D382,218	S	8/1997	Hall	
D397,364	S	8/1998	Barrett	
D438,820	S *	3/2001	Goulding	D11/166
D493,491	S *	7/2004	Smedley et al.	D20/19
D508,540	S *	8/2005	Smedley et al.	D20/19
D530,756	S *	10/2006	Greenwald	D21/405
7,147,399	B2 *	12/2006	Viscount et al.	403/349
7,236,146	B2 *	6/2007	Smedley et al.	345/31
D550,289	S *	9/2007	Prokop	D20/41
2005/0204599	A1 *	9/2005	Myles	40/591
2006/0053667	A1 *	3/2006	Andersen	40/591

* cited by examiner

Primary Examiner—Robert M. Spear
Assistant Examiner—Mary Ann Calabrese
(74) *Attorney, Agent, or Firm*—Senninnger Powers LLP

(57) **CLAIM**

The ornamental design for a vehicle sign having base and flag, as shown and described.

DESCRIPTION

FIG. 1 is a perspective view of a vehicle sign having base and flag incorporating my design;

FIG. 2 is an enlarged perspective view of the flag of the vehicle sign of FIG. 1 incorporating my design removed from the base for clarity of disclosure;

FIG. 3 is a reduced scale front elevational view of the flag of FIG. 2;

FIG. 4 is a top plan view of the flag of FIG. 2;

FIG. 5 is a right side elevational view of the flag of FIG. 2;

FIG. 6 is a reduced scale rear elevational view of the flag of FIG. 2;

FIG. 7 is a bottom plan view of the flag of FIG. 2;

FIG. 8 is a left side elevational view of the flag of FIG. 2;

FIG. 9 is a perspective view of the base of the vehicle sign of FIG. 2 incorporating my design with the flag removed for clarity of disclosure;

FIG. 10 is a left side elevational view of the base of FIG. 9;

FIG. 11 is a top plan view of the base of FIG. 9;

FIG. 12 is a front elevational view of the base of FIG. 9;

FIG. 13 is a right side elevational view of the base of FIG. 9;

FIG. 14 is a bottom plan view of the base of FIG. 9; and,

FIG. 15 is a rear elevational view of the base of FIG. 9.

1 Claim, 15 Drawing Sheets

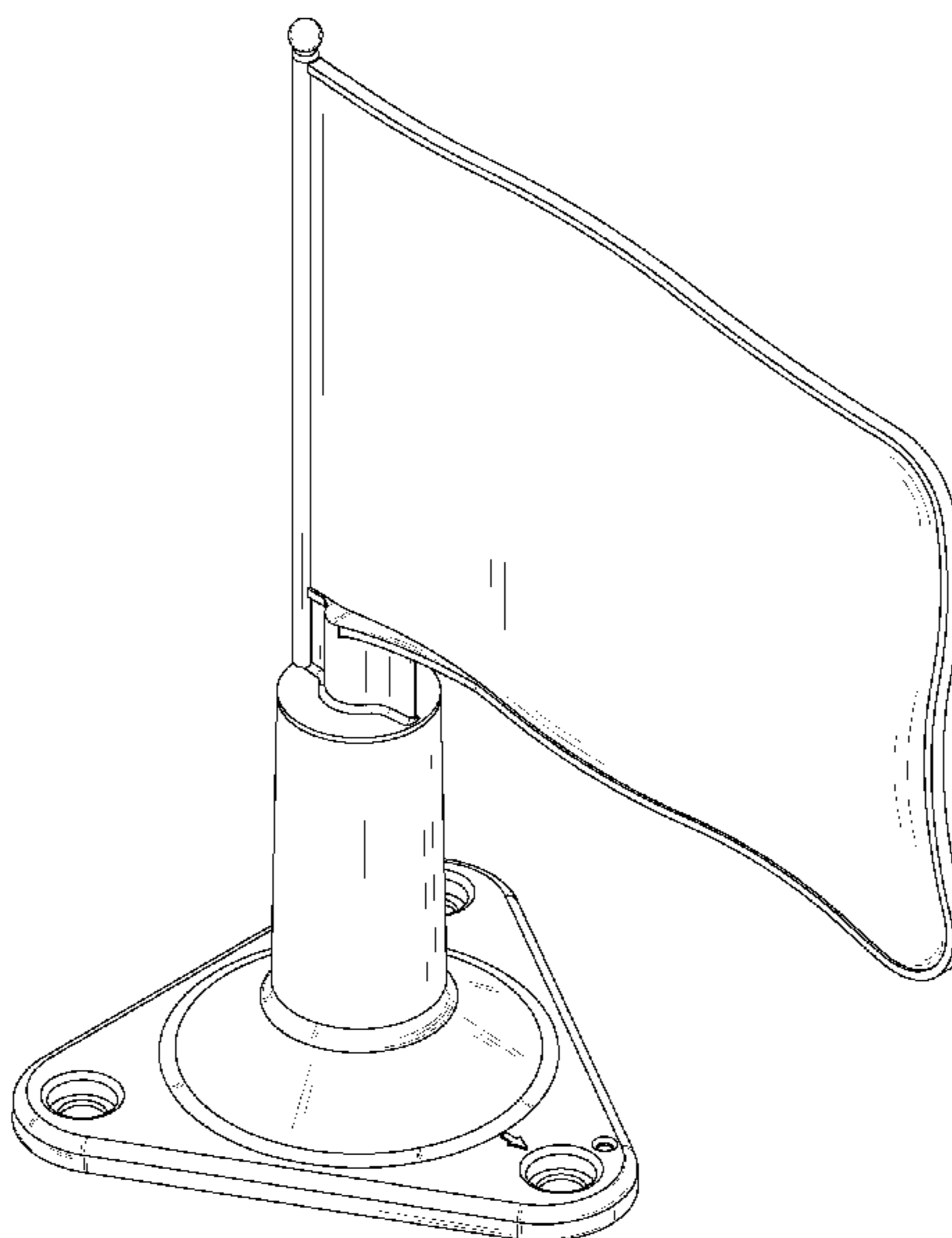

FIG. 1

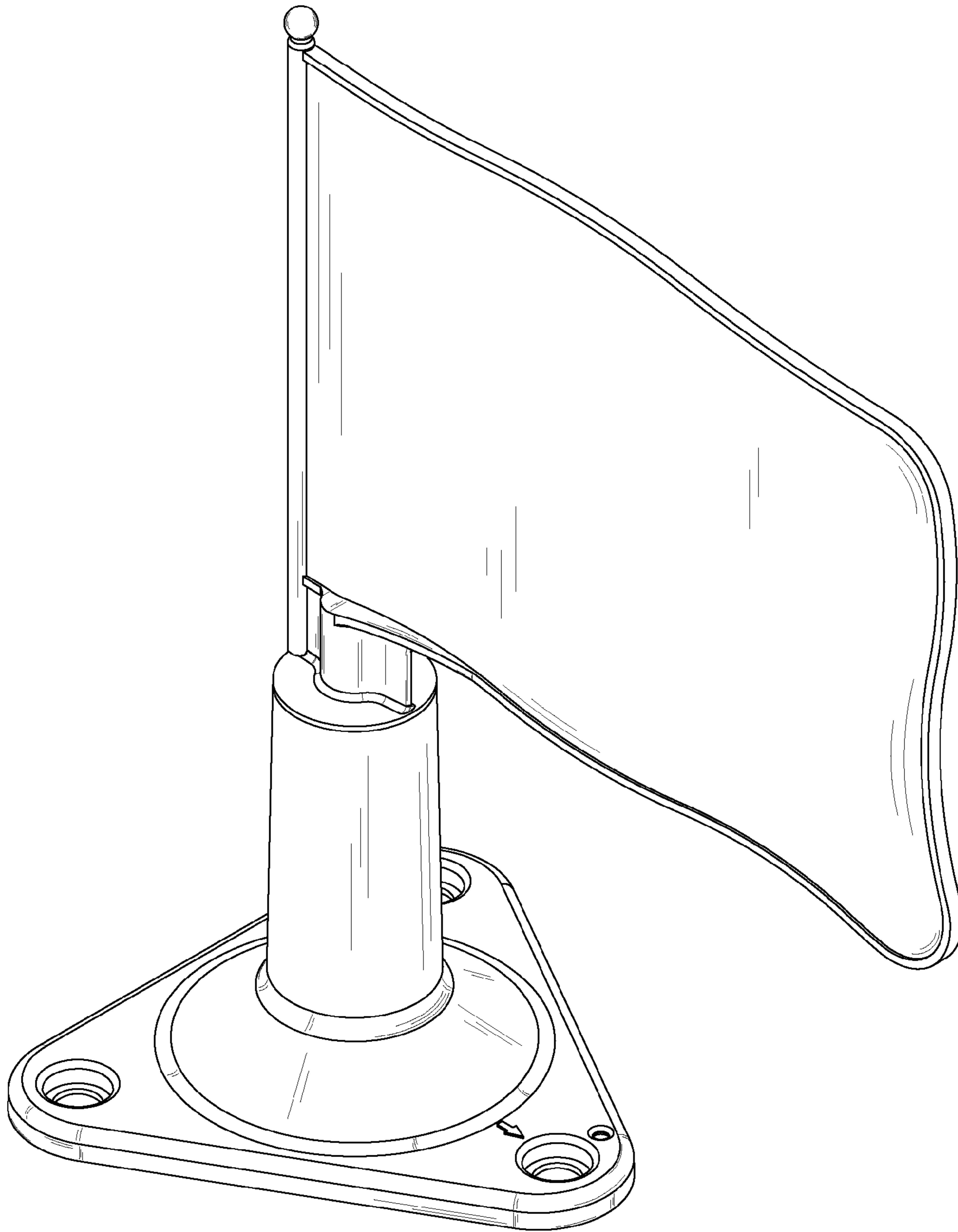

FIG. 2

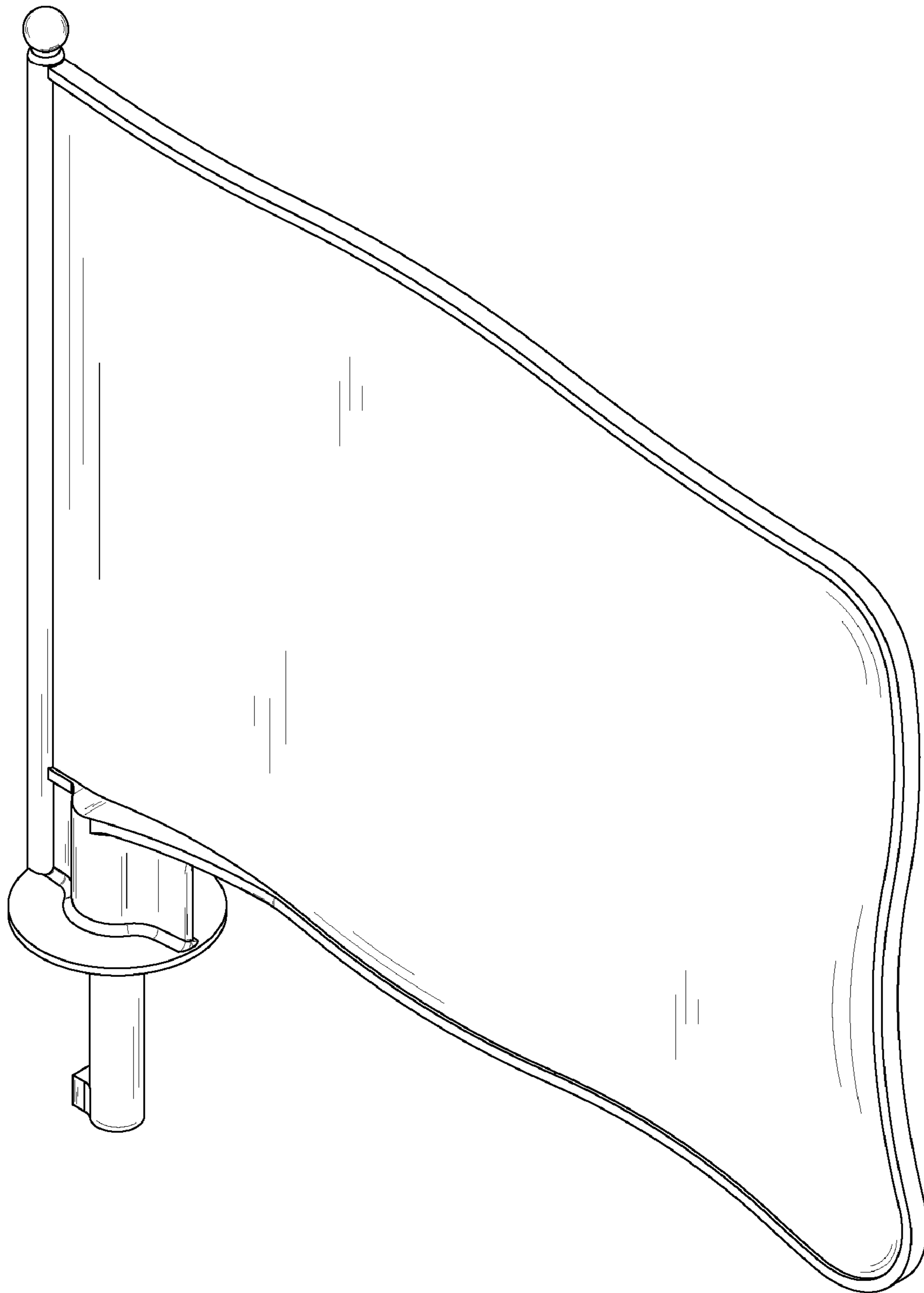
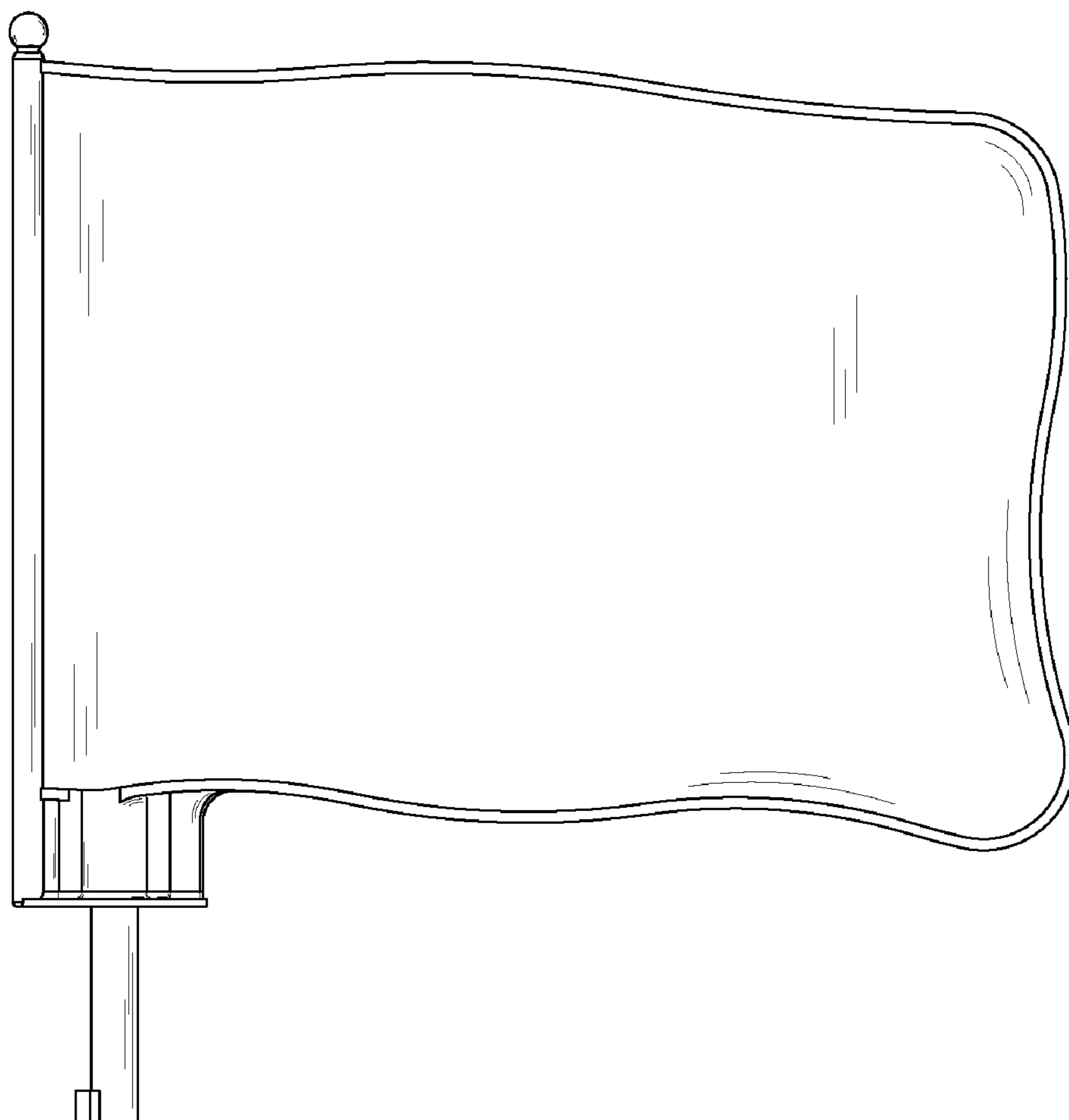

FIG. 3



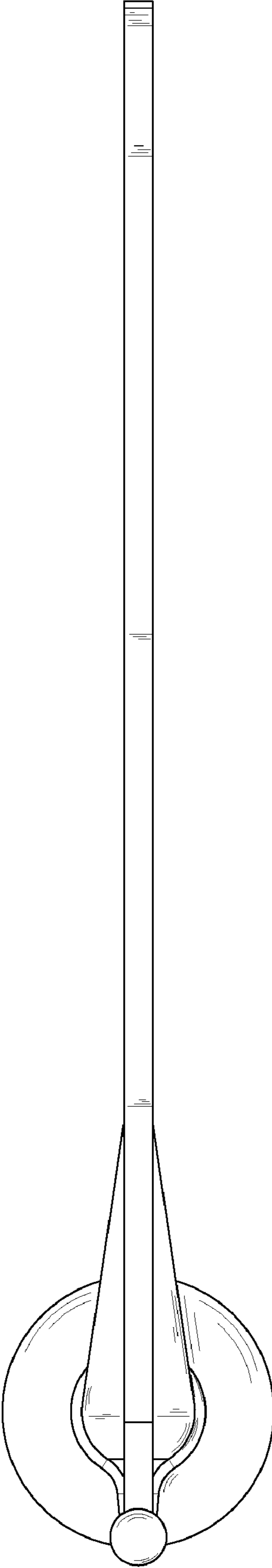

FIG. 4

FIG. 5

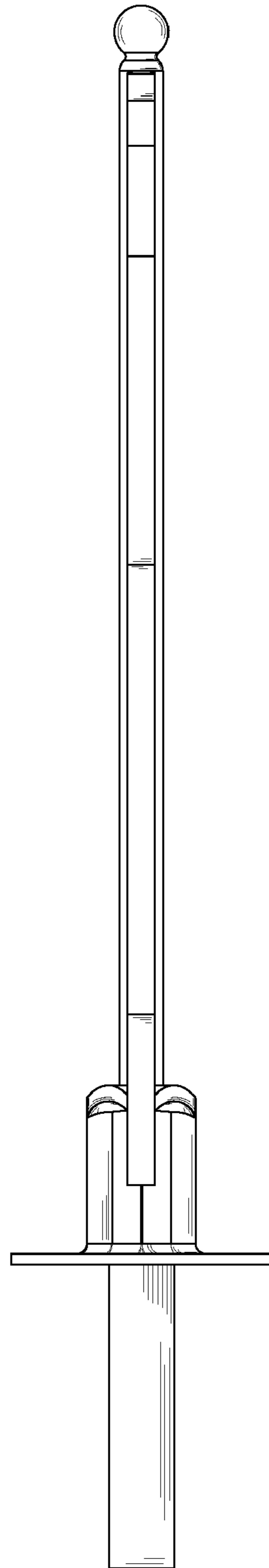
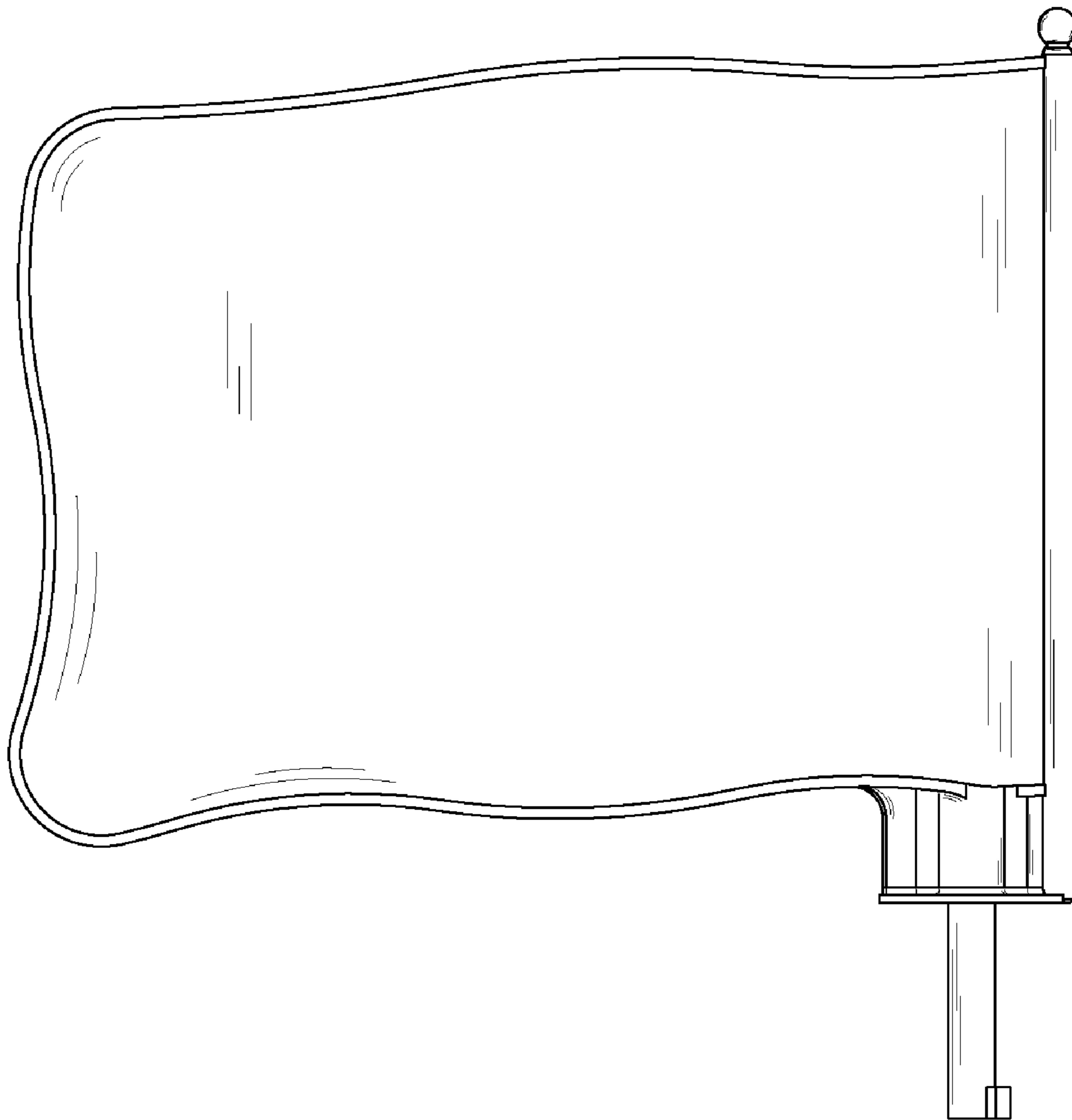

FIG. 6



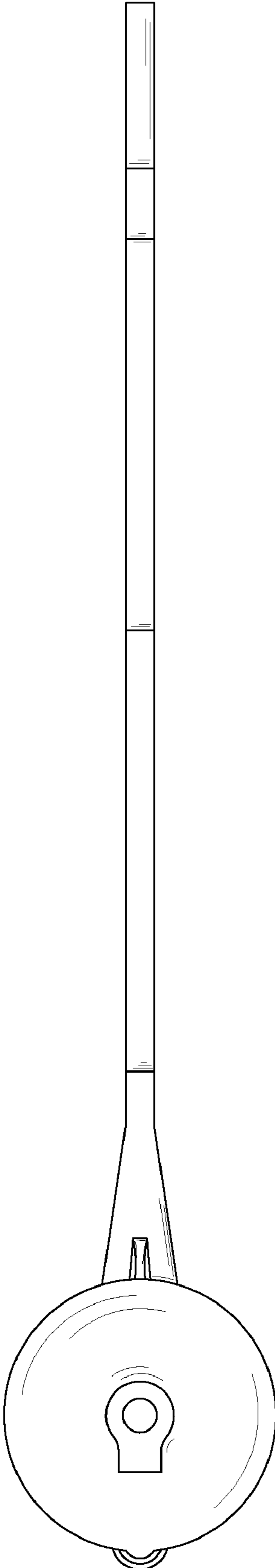

FIG. 7

FIG. 8

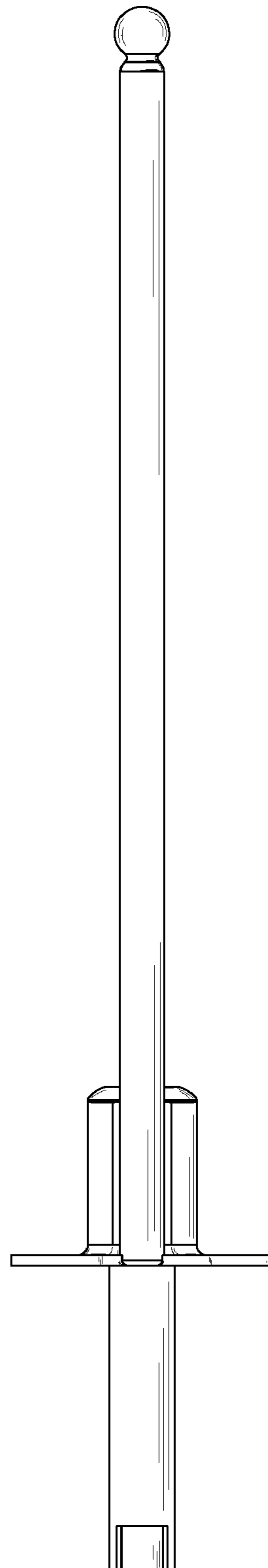

FIG. 9

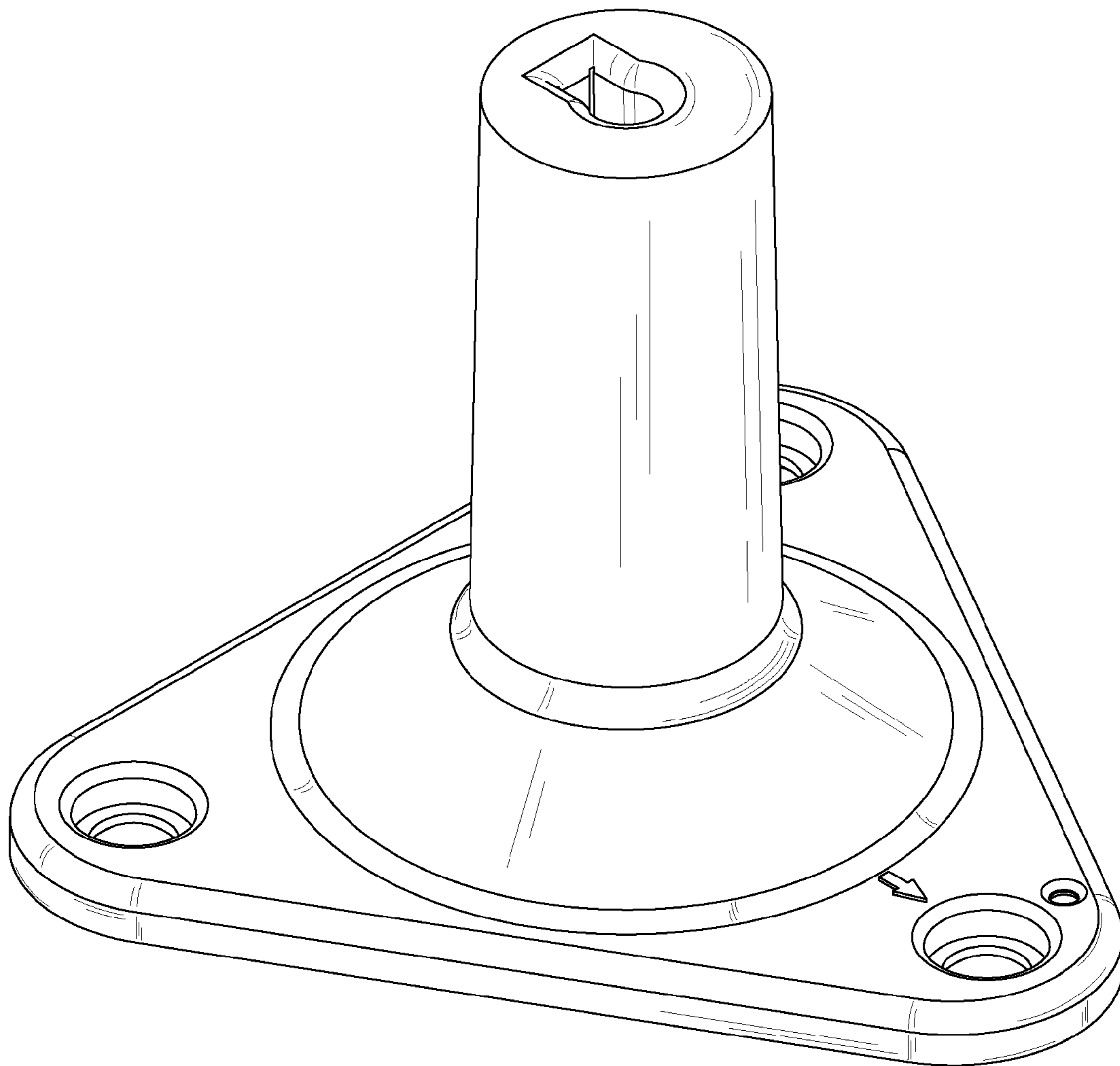

FIG. 10

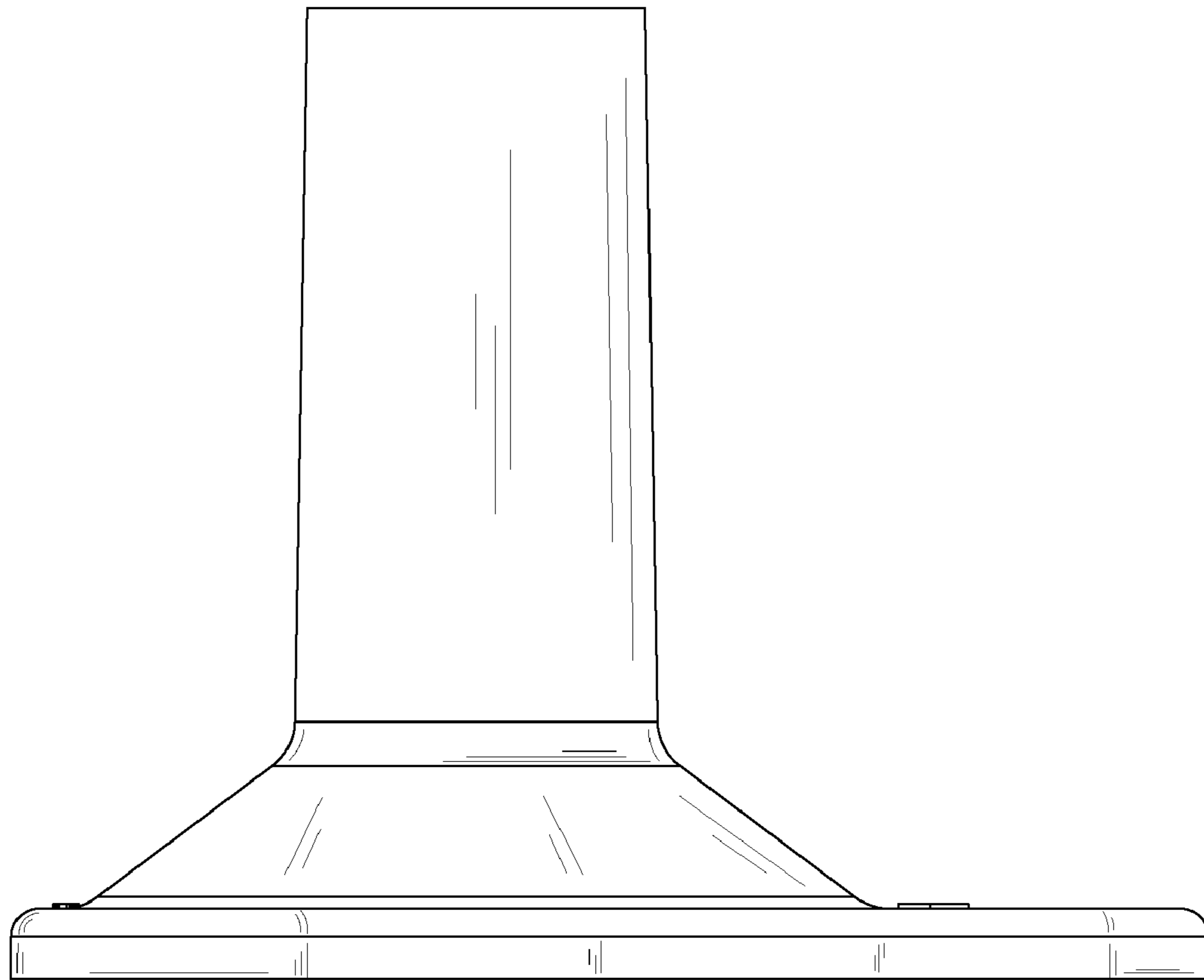

FIG. 11

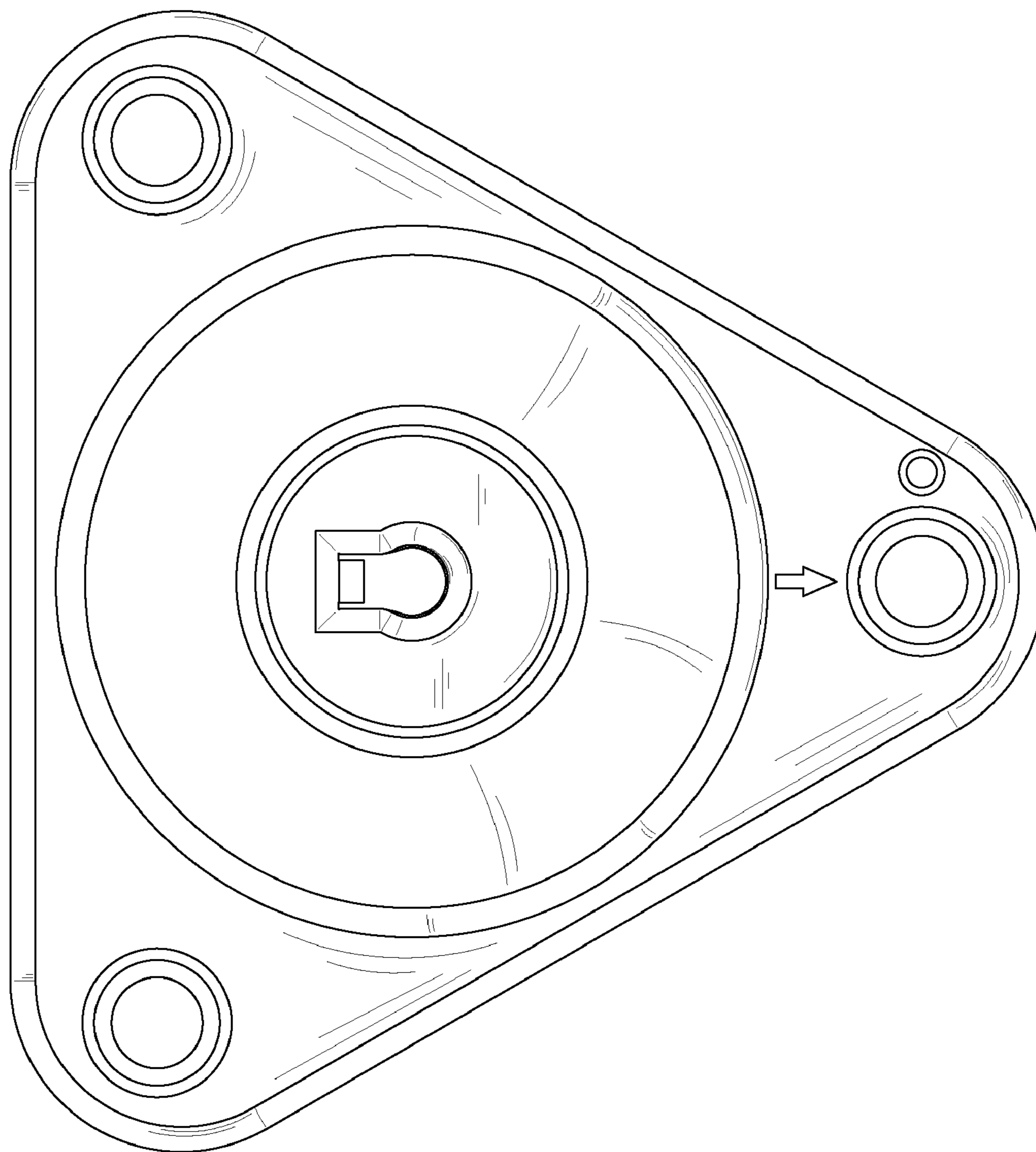

FIG. 12

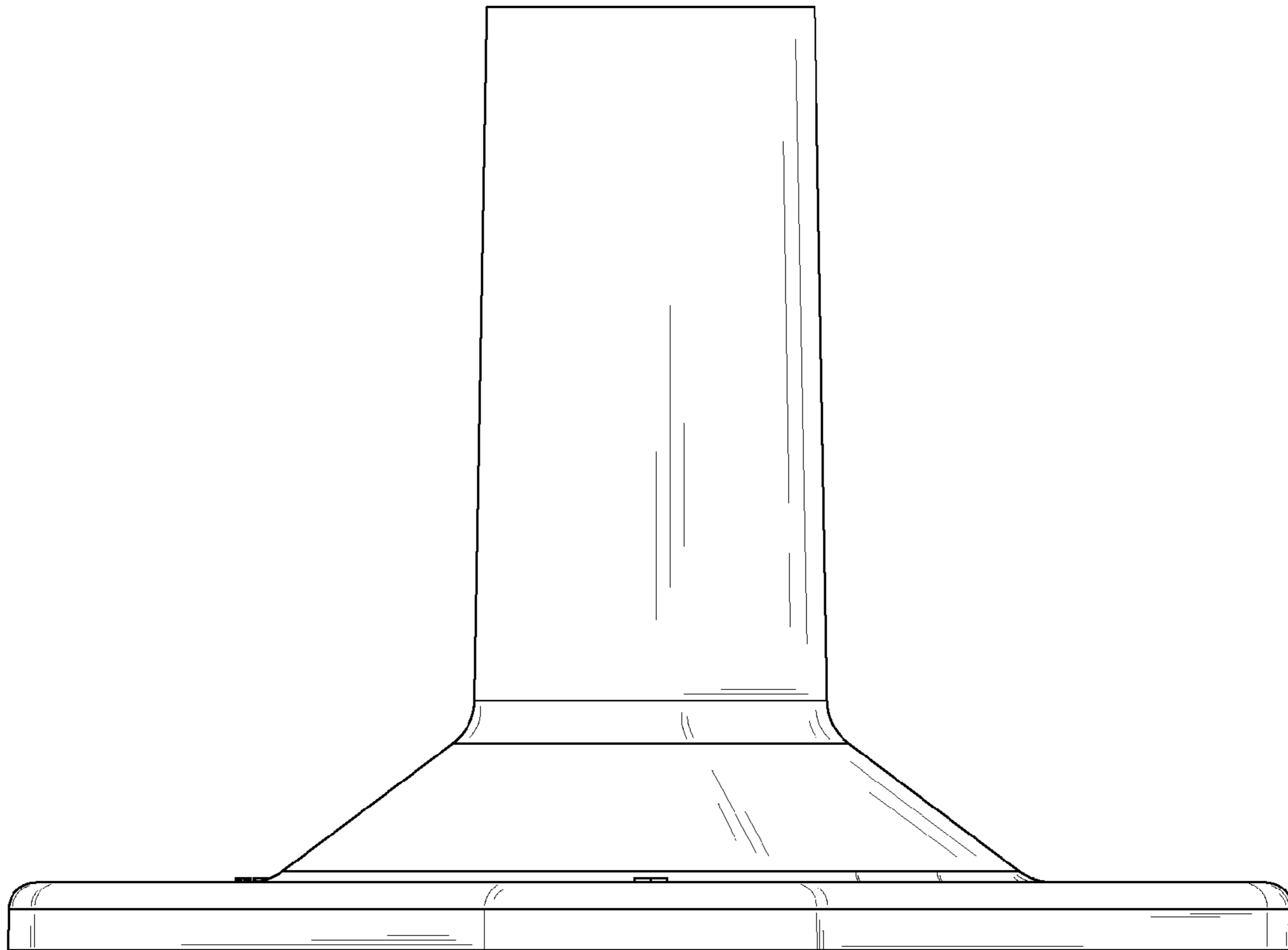

FIG. 13

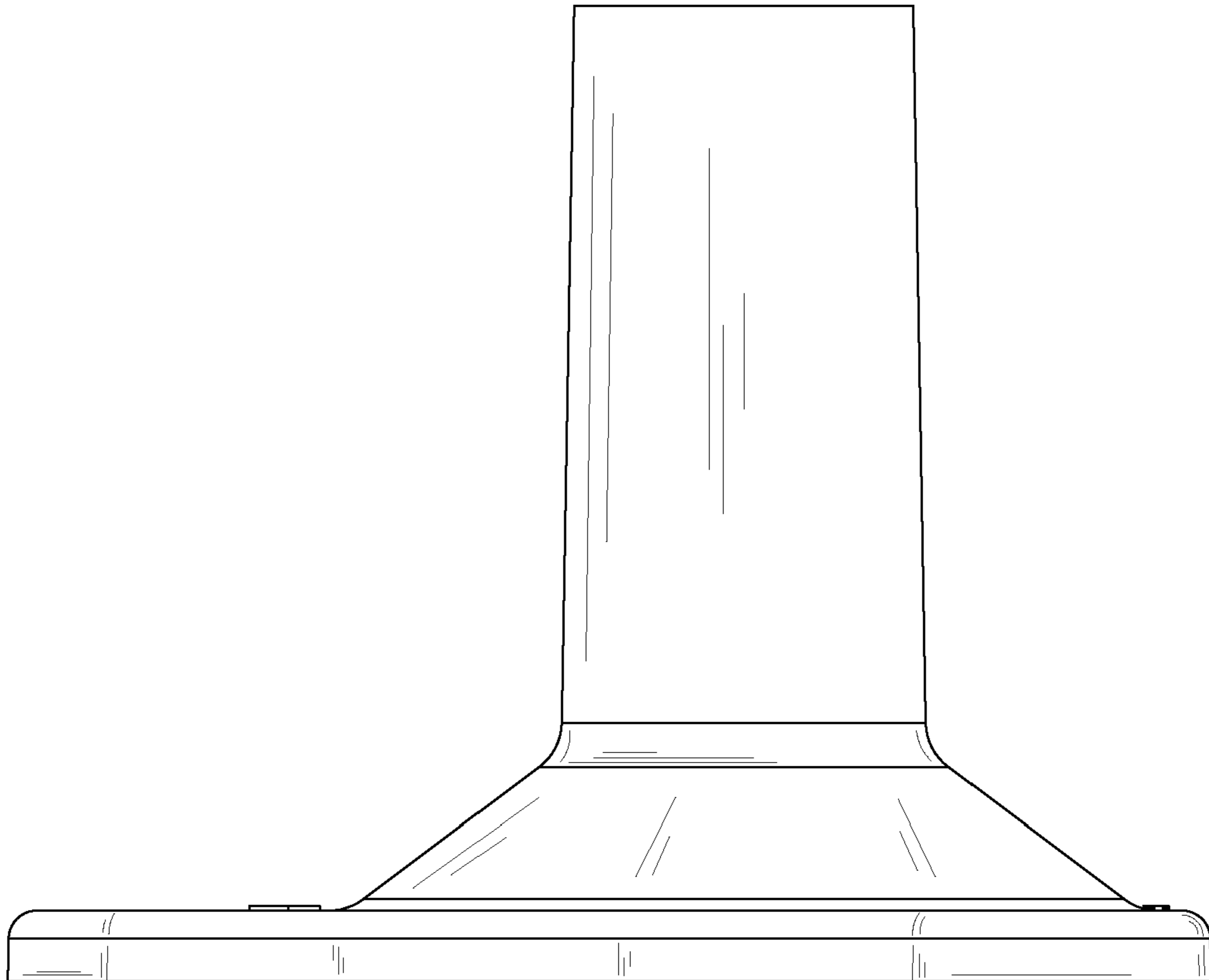

FIG. 14

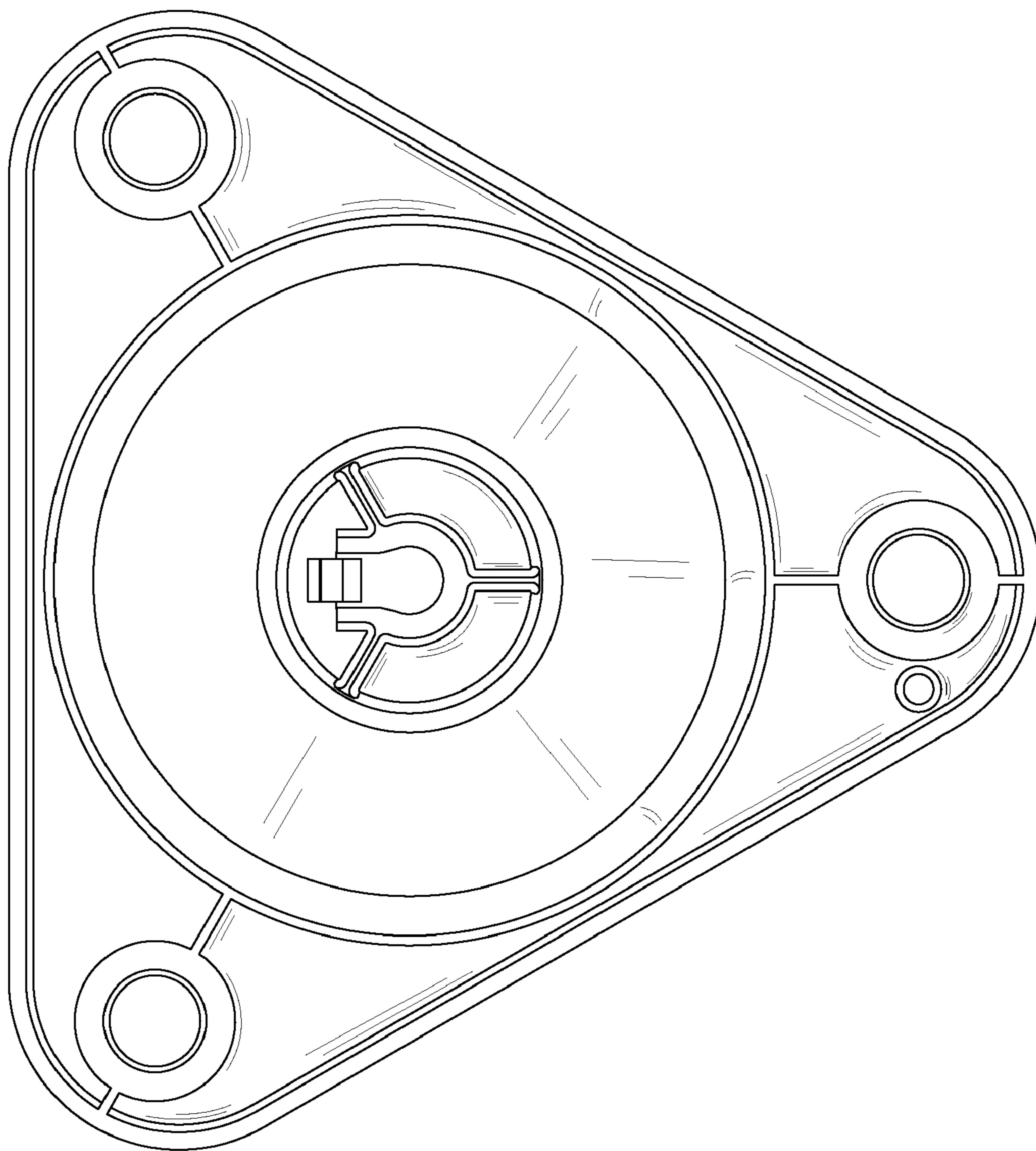

FIG. 15

