



US00D564439S

(12) **United States Design Patent**
Vitito

(10) **Patent No.:** **US D564,439 S**
(45) **Date of Patent:** **** Mar. 18, 2008**

(54) **BASE WITH DOMELAMPS FOR AN
AUTOMOBILE ENTERTAINMENT SYSTEM**

(76) **Inventor:** **Christopher J. Vitito**, 514
Longmeadow St., Celebration, FL (US)
34747

(**) **Term:** **14 Years**

(21) **Appl. No.:** **29/272,814**

(22) **Filed:** **Feb. 20, 2007**

(51) **LOC (8) Cl.** **12-16**

(52) **U.S. Cl.** **D12/418; D14/132**

(58) **Field of Classification Search** D12/418,
D12/415, 400, 195; D14/132, 124, 126,
D14/129, 113, 133, 100; 296/37.1-37.8,
296/70, 24.1, 929, 534; 224/311, 539; 180/90;
439/34; 361/683

See application file for complete search history.

(56) **References Cited**

U.S. PATENT DOCUMENTS

D467,234 S *	12/2002	Scribner	D14/132
D467,562 S *	12/2002	Chang	D14/132
D489,044 S *	4/2004	Bremenkamp et al.	D14/132
D489,812 S *	5/2004	Huang	D23/411
7,084,932 B1 *	8/2006	Mathias et al.	348/837
7,124,989 B1 *	10/2006	Lee et al.	248/288.11
D535,246 S *	1/2007	Vitito	D12/418
D535,269 S *	1/2007	Vitito	D14/132
D539,768 S *	4/2007	Vitito	D14/132

D550,608 S *	9/2007	Vitito	D12/418
D555,071 S *	11/2007	Vitito	D12/418
2003/0184111 A1 *	10/2003	Sturt	296/37.8
2005/0141183 A1 *	6/2005	Chen	361/683

* cited by examiner

Primary Examiner—Robert M. Spear
Assistant Examiner—Katrina A Kile
(74) *Attorney, Agent, or Firm*—Welsh & Flaxman LLC

(57) **CLAIM**

The ornamental design for a base with domelamps for an automobile entertainment system, as shown and described.

DESCRIPTION

FIG. 1 is a front perspective view of a base with domelamps for an automobile entertainment system showing my new design.

FIG. 2 is a rear perspective view of thereof.

FIG. 3 is a front elevational view thereof;

FIG. 4 is a rear elevational view thereof;

FIG. 5 is a right side elevational view thereof;

FIG. 6 is a left side elevational view thereof; and,

FIG. 7 is a bottom plan view thereof.

The broken lines in the drawings are for the purpose of showing environmental structure and do not form part of the claimed design.

1 Claim, 5 Drawing Sheets

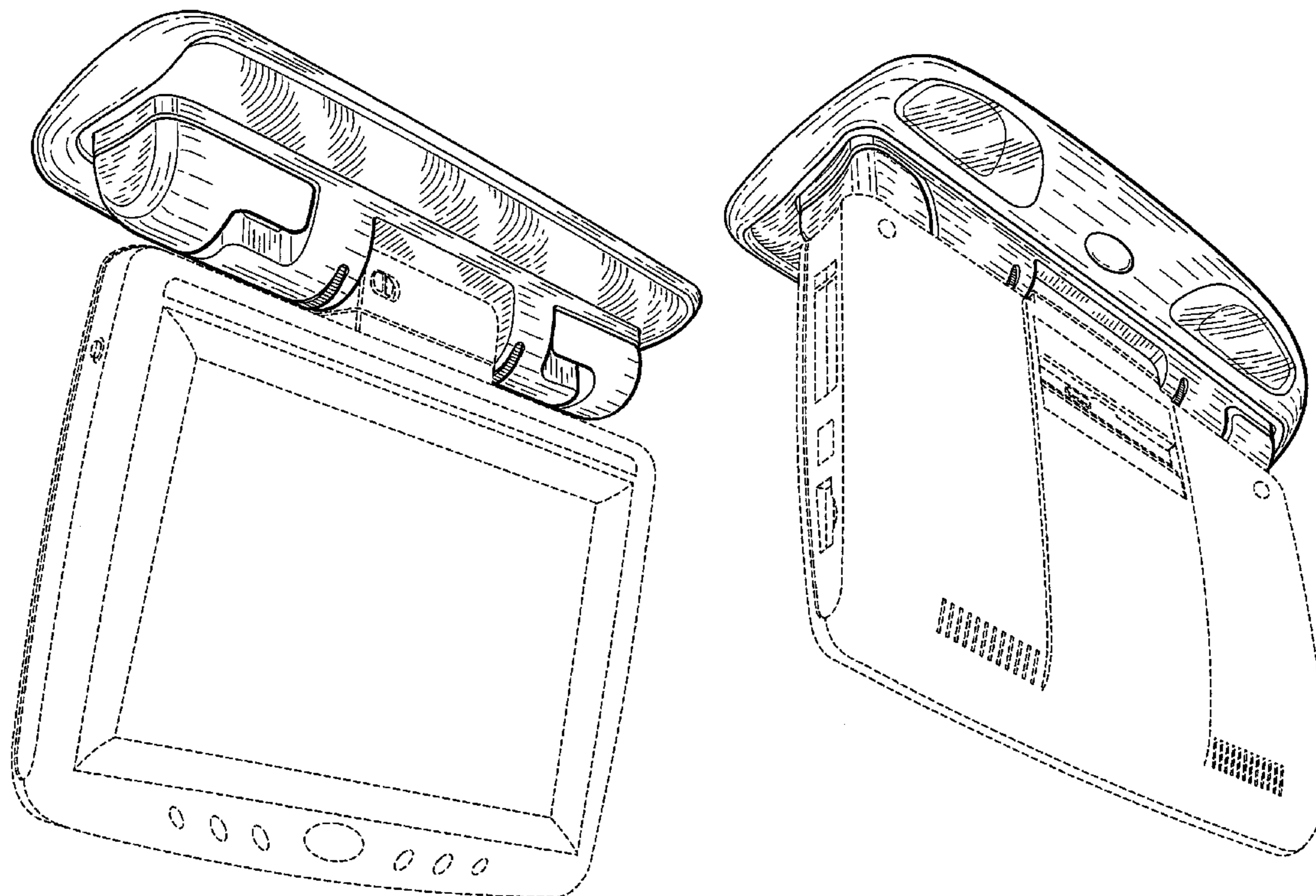

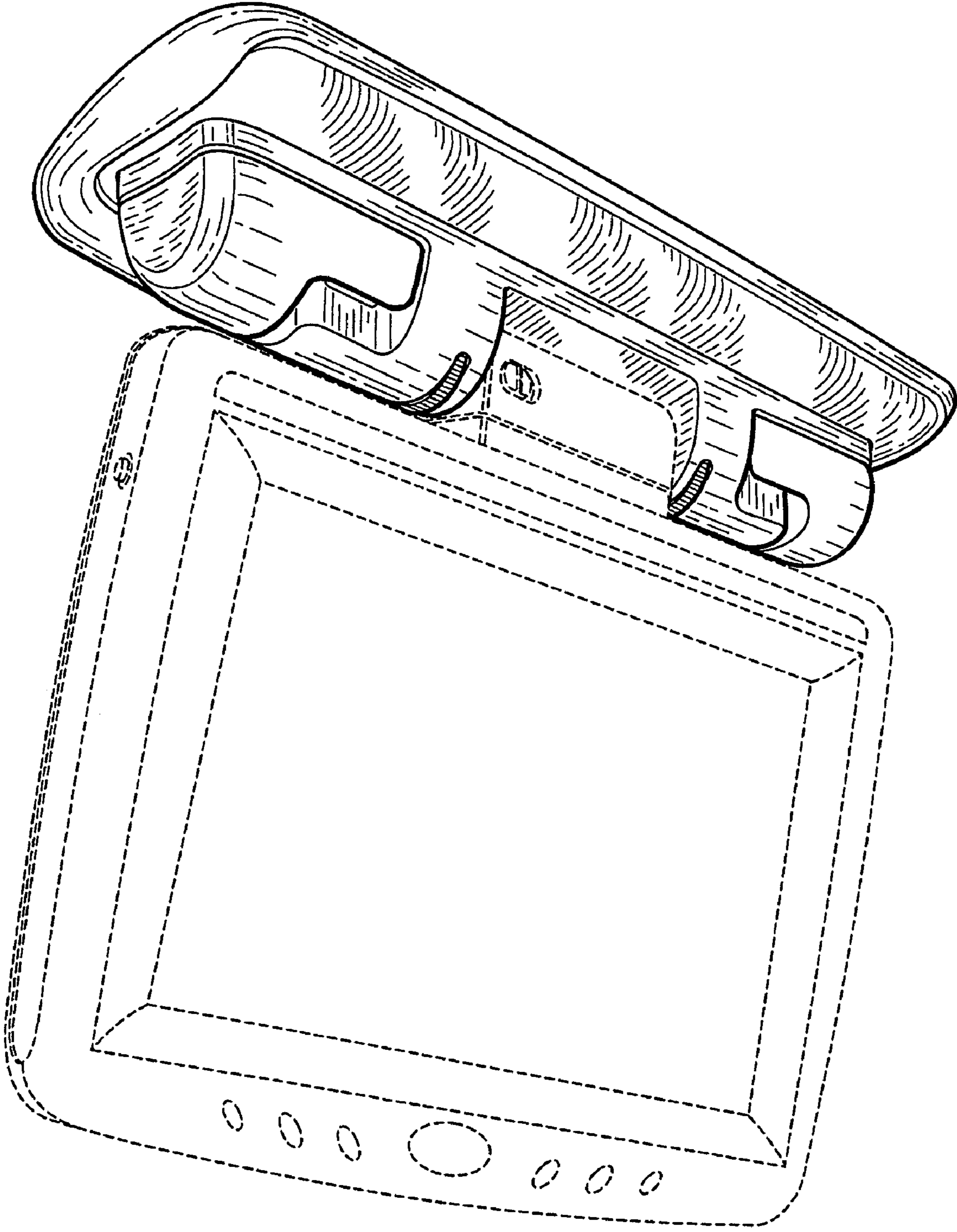

FIG. 1

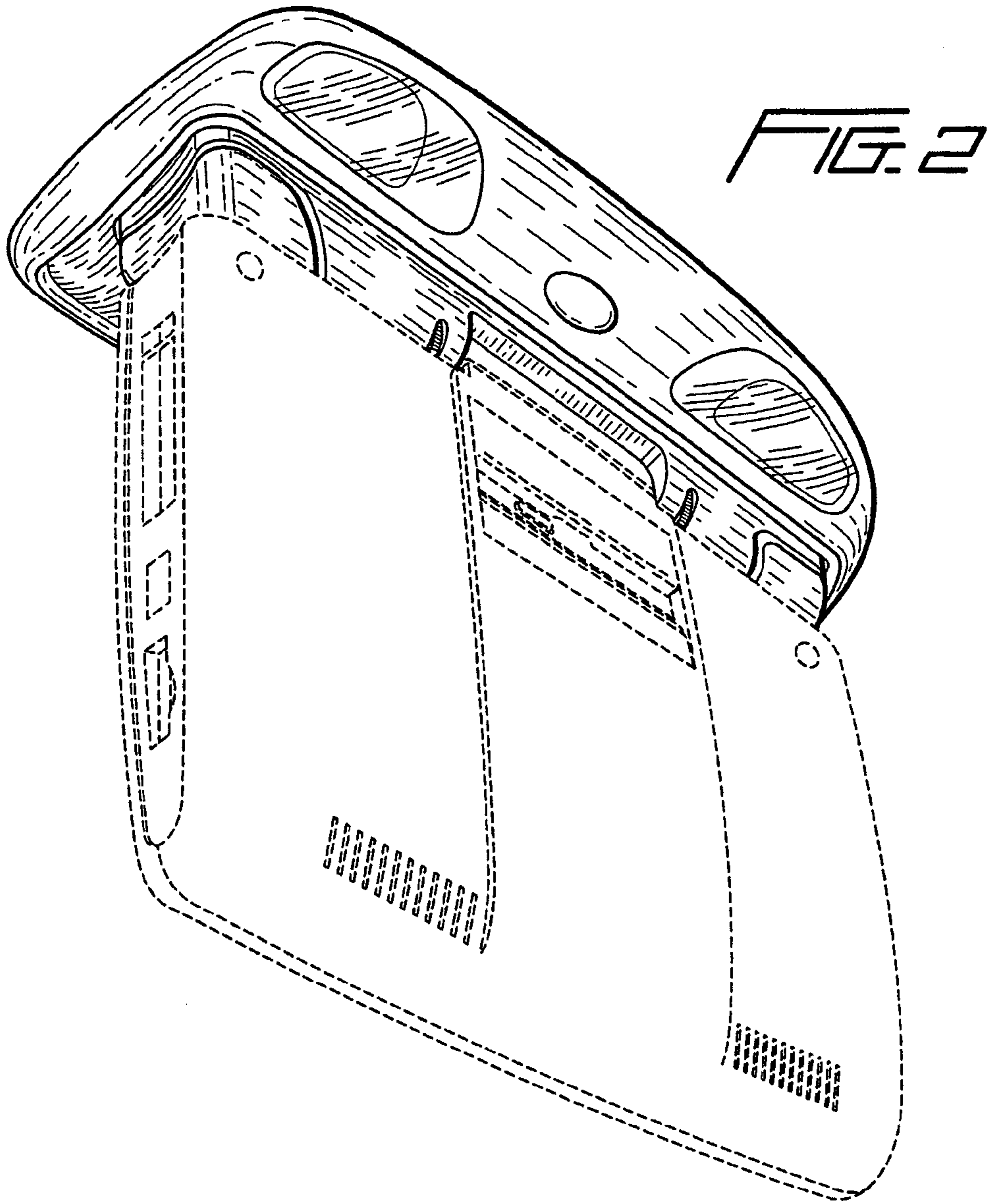
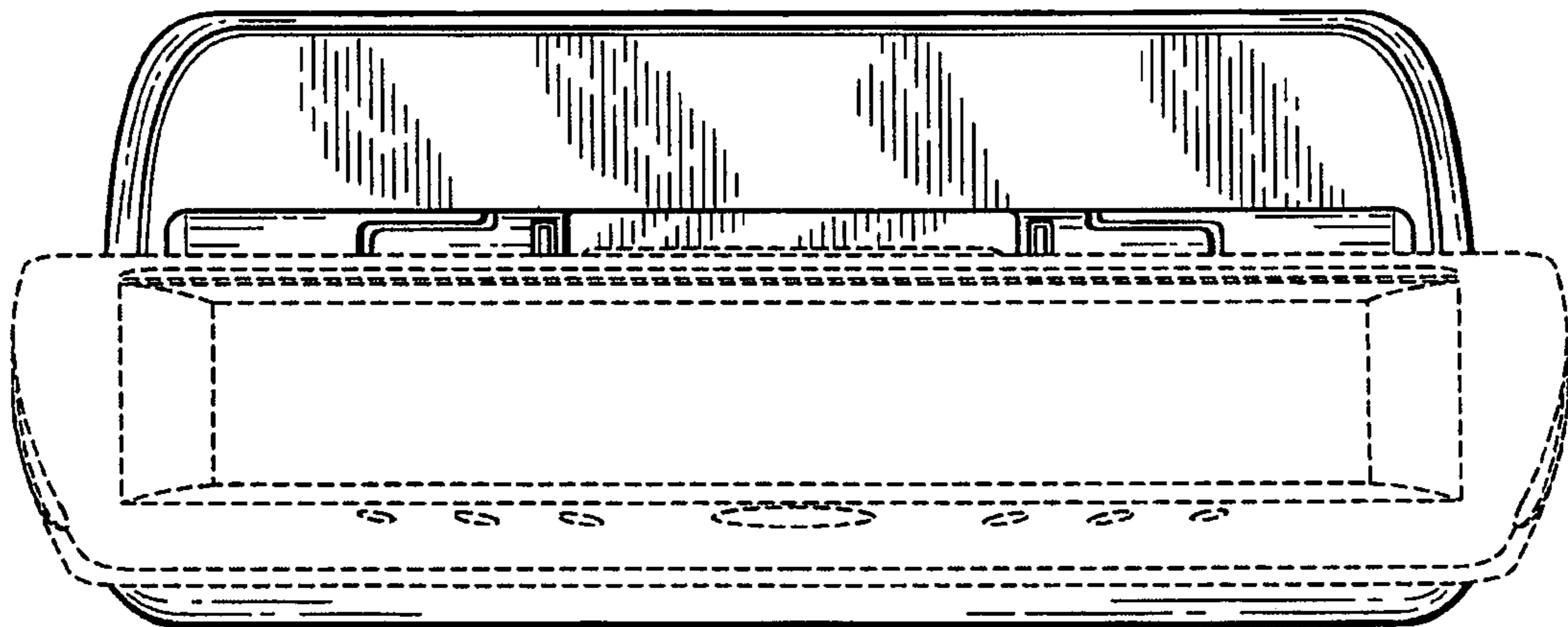

FIG. 7



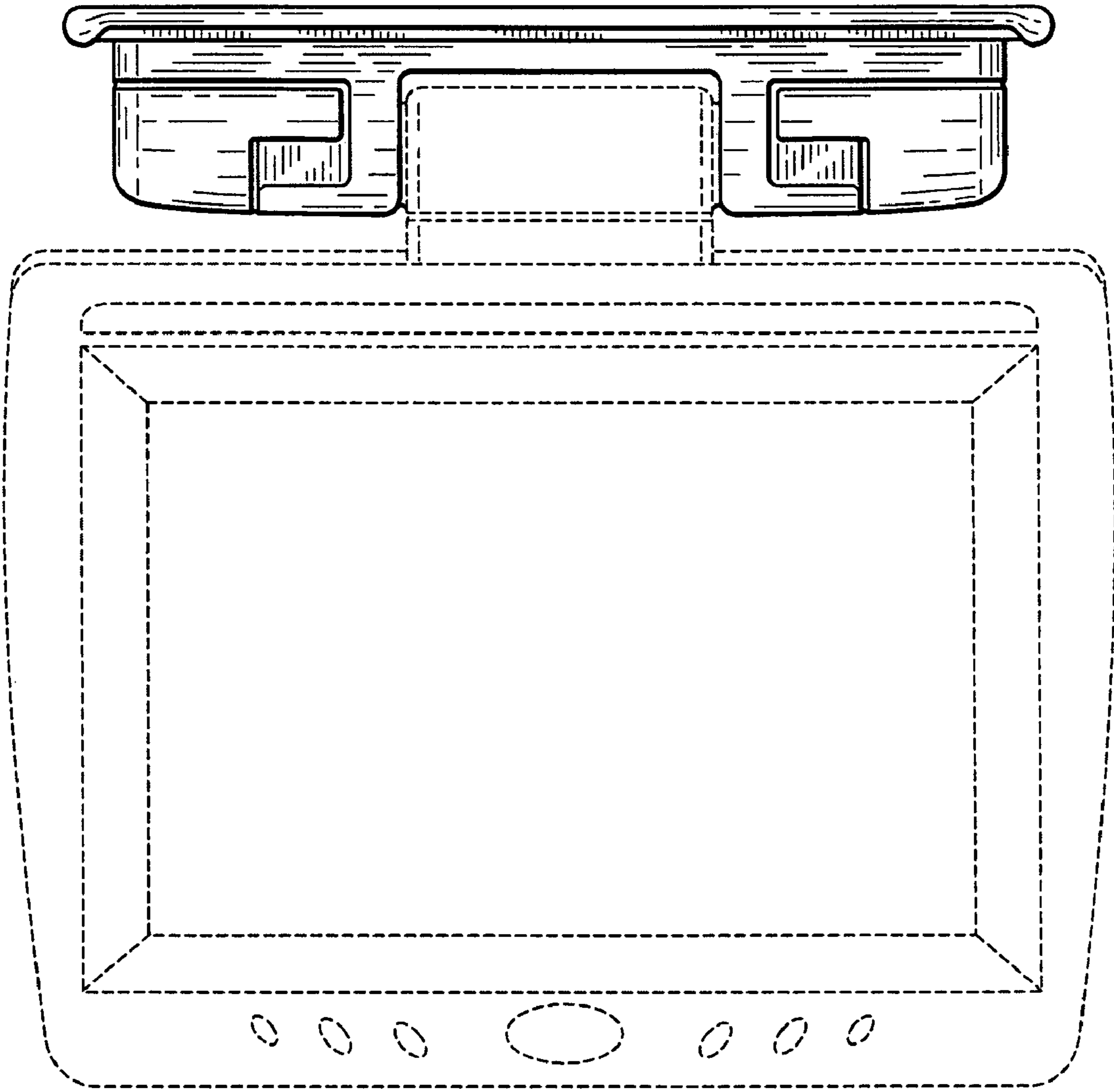

FIG. 3

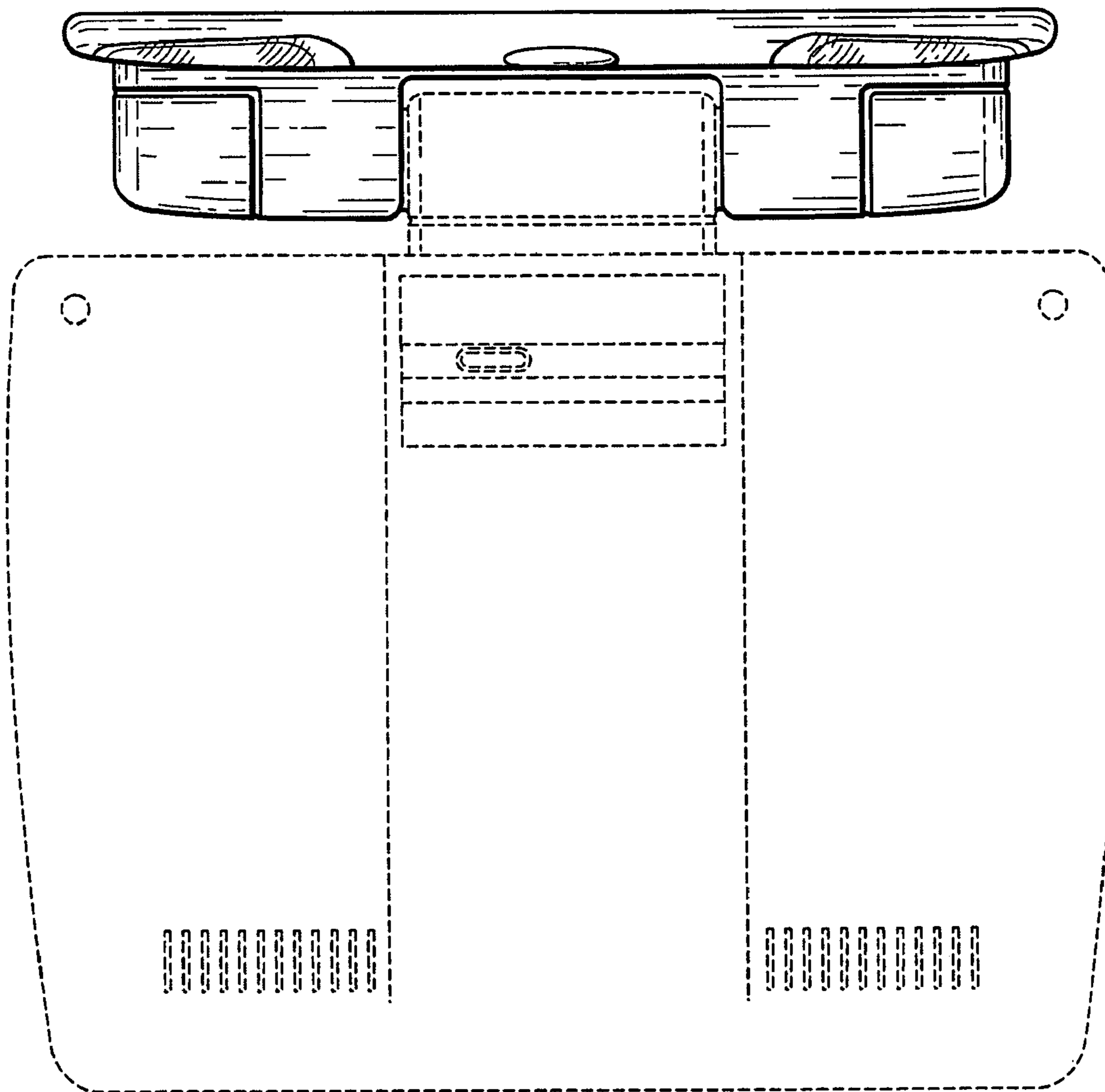

FIG. 4

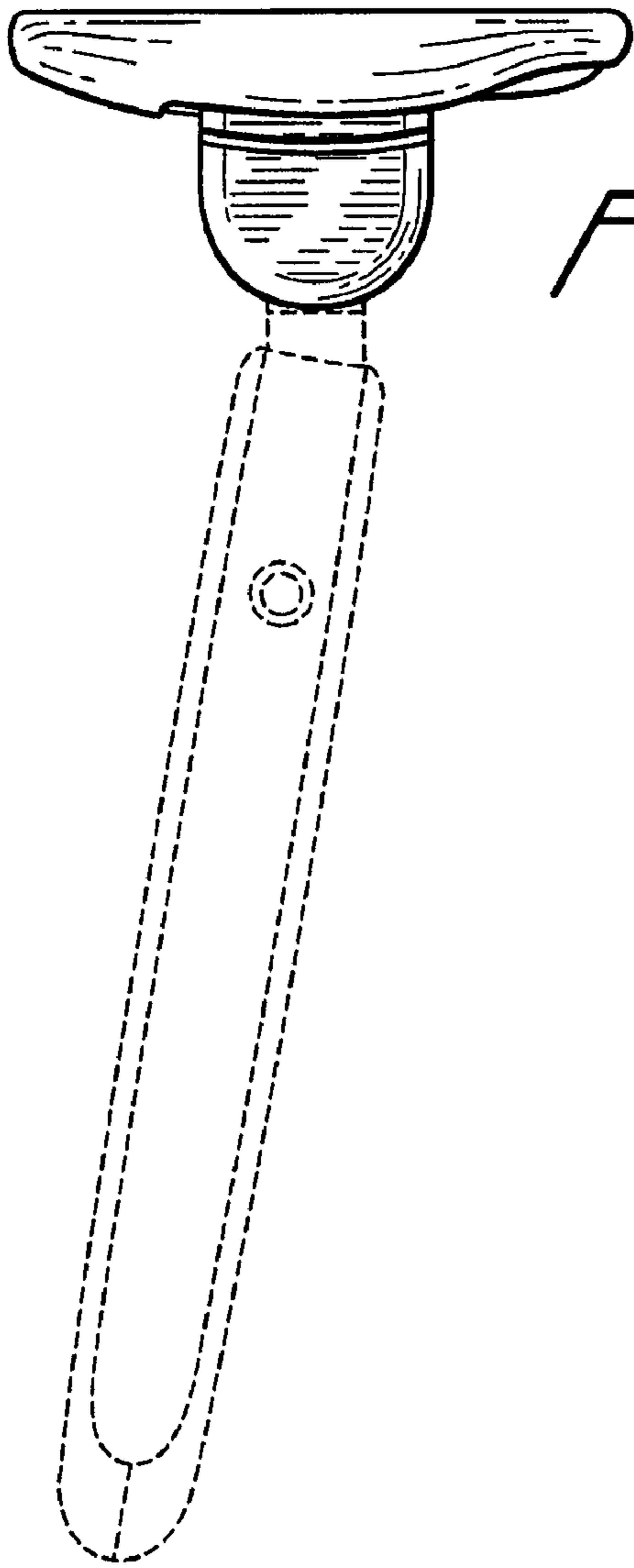

FIG. 5

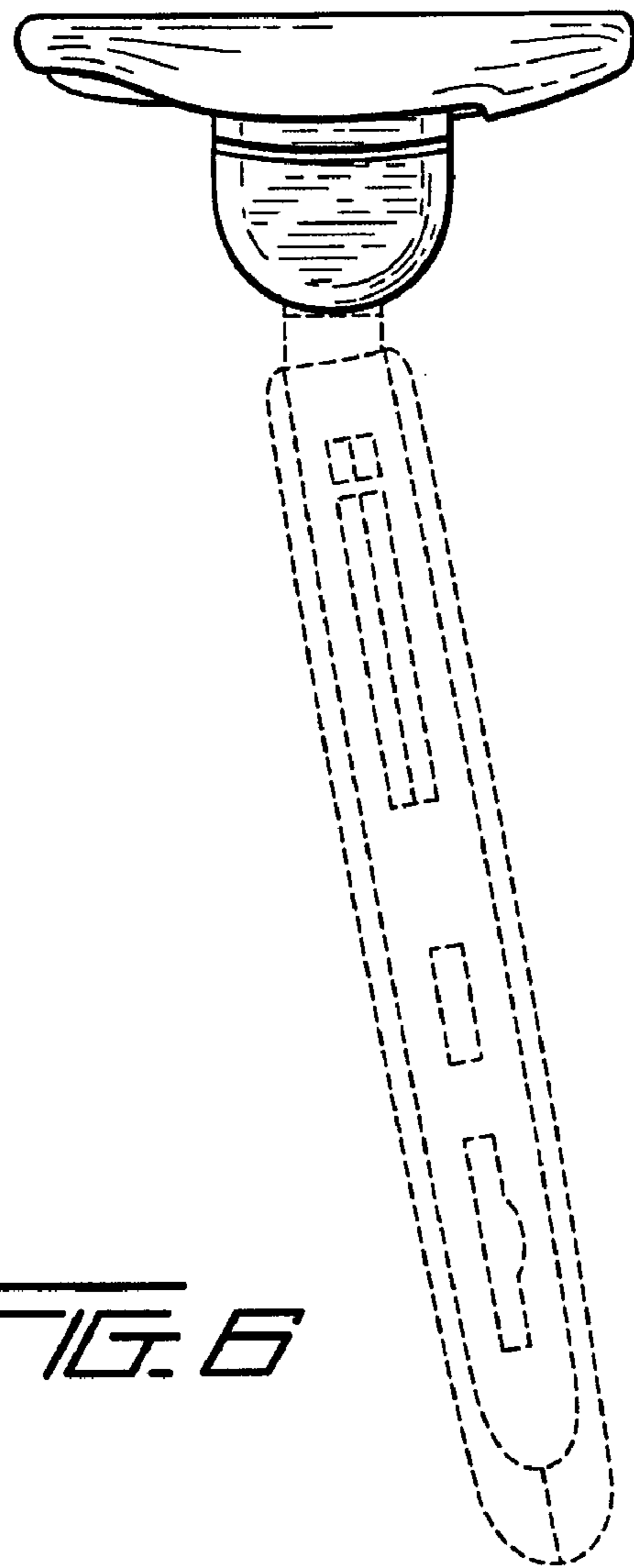

FIG. 6