



US00D564436S

(12) **United States Design Patent**
Chambers

(10) **Patent No.:** **US D564,436 S**

(45) **Date of Patent:** **** Mar. 18, 2008**

(54) **SAILBOAT HULL**

D514,499 S * 2/2006 Valdes D12/303

(75) Inventor: **Curtis Chambers**, Muskegon, MI (US)

* cited by examiner

(73) Assignee: **Nauticraft Corporation**, Muskegon, MI (US)

Primary Examiner—Holly H. Baynham

Assistant Examiner—Cynthia M. Chin

(74) *Attorney, Agent, or Firm*—McGarry Bair PC

(**) Term: **14 Years**

(21) Appl. No.: **29/278,408**

(22) Filed: **Mar. 28, 2007**

(51) **LOC (8) Cl.** **12-06**

(52) **U.S. Cl.** **D12/300**

(58) **Field of Classification Search** D12/300,
D12/302, 303, 310–313, 317; 114/39.11–39.15,
114/39.21–39.32, 355–358

See application file for complete search history.

(56) **References Cited**

U.S. PATENT DOCUMENTS

D195,157 S *	4/1963	Luger	D12/300
D244,015 S *	4/1977	Grind	D12/300
D265,475 S *	7/1982	Pape	D12/303
D447,994 S *	9/2001	Morejohn	D12/300
D448,339 S *	9/2001	Morejohn	D12/300
D514,054 S *	1/2006	Blount	D12/300

(57) **CLAIM**

The ornamental design for a sailboat hull, as shown and described.

DESCRIPTION

FIG. 1 is a front perspective view of the sailboat hull which embodies my design;

FIG. 2 is a front view thereof;

FIG. 3 is a rear view thereof;

FIG. 4 is a left side view thereof, the right side view thereof being a mirror image of the left side view thereof;

FIG. 5 is a top view thereof; and,

FIG. 6 is a bottom view thereof.

The broken lines shown in the drawings are for illustrative purposes only and form no part of the claimed design.

1 Claim, 4 Drawing Sheets

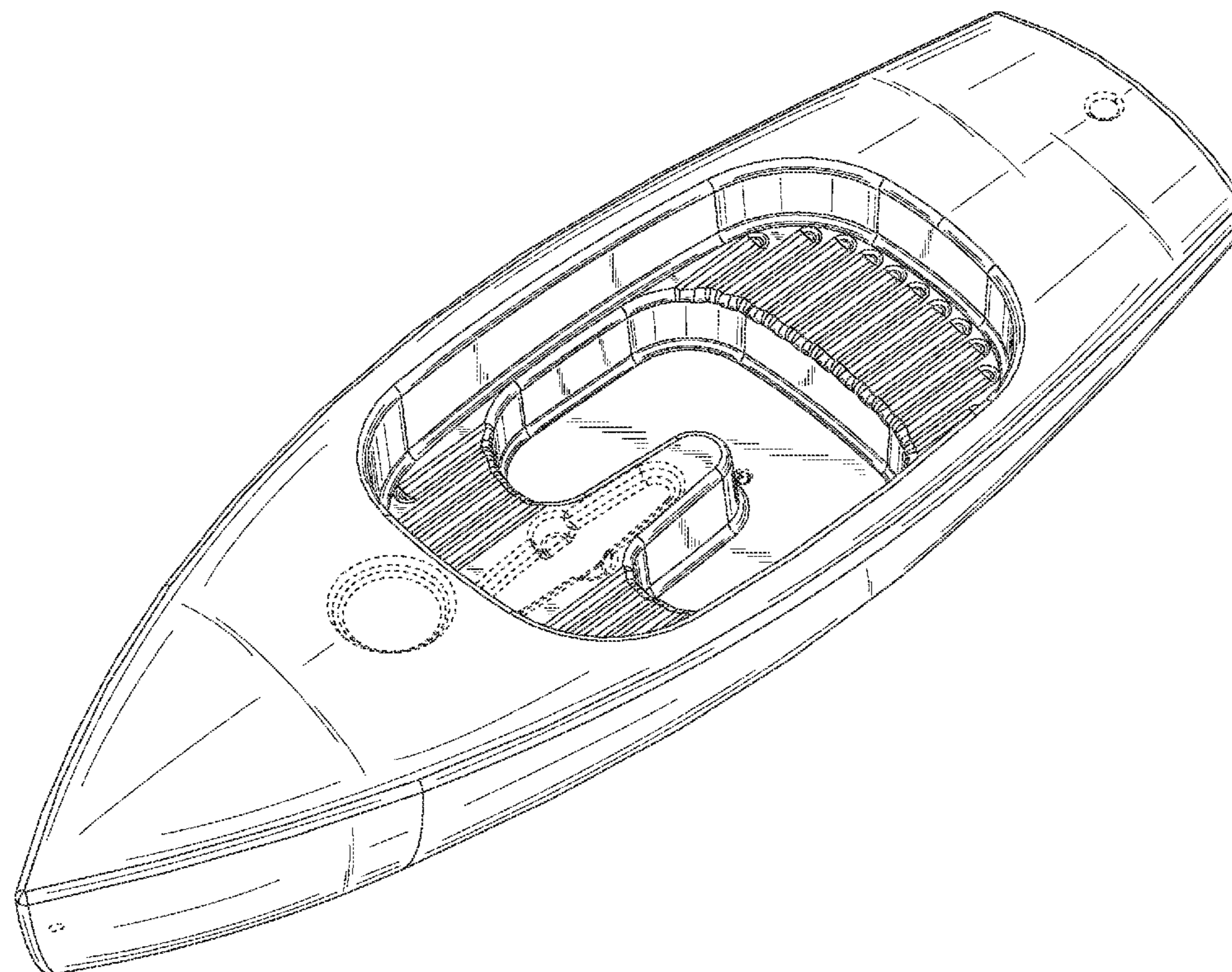

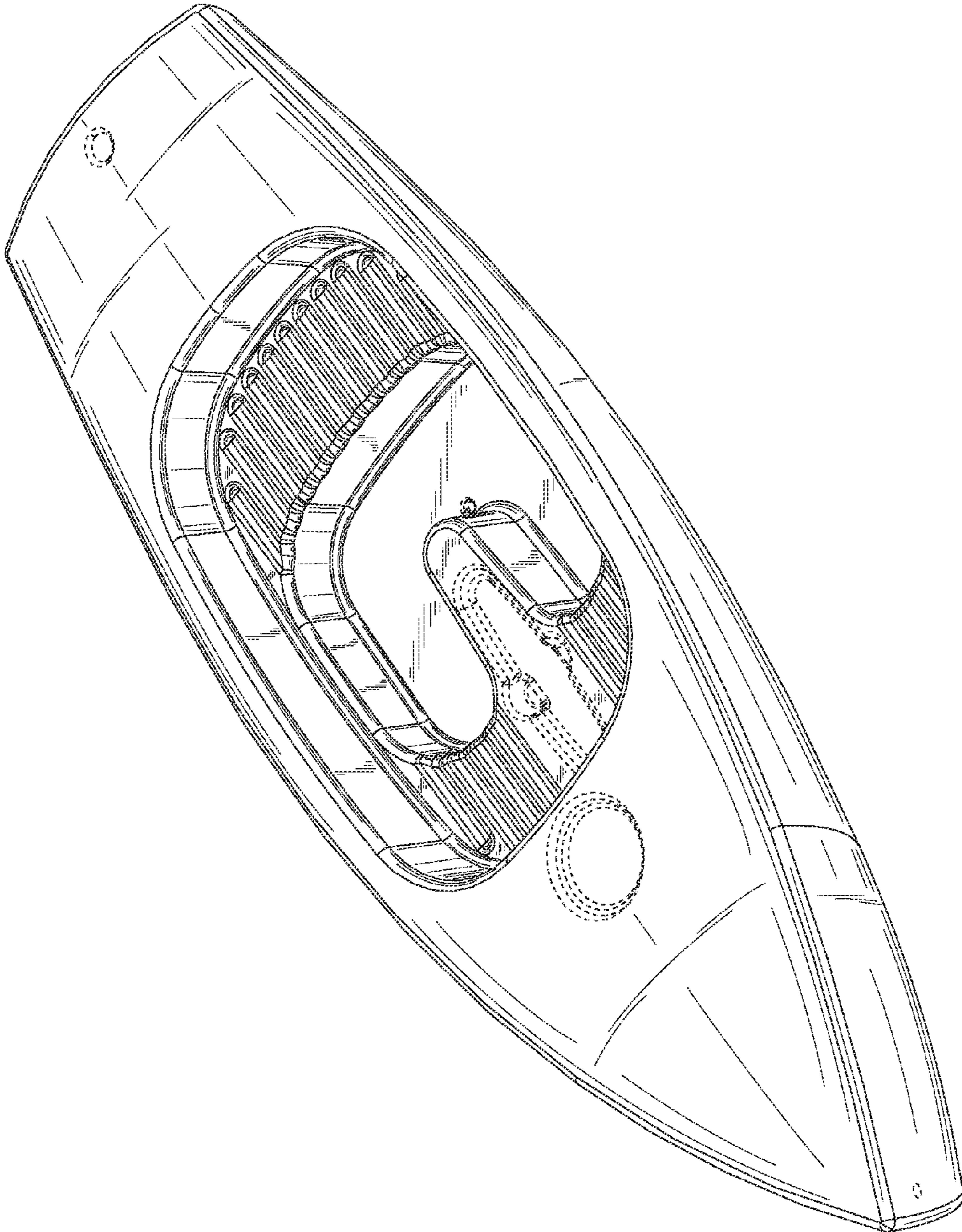

Fig. 1

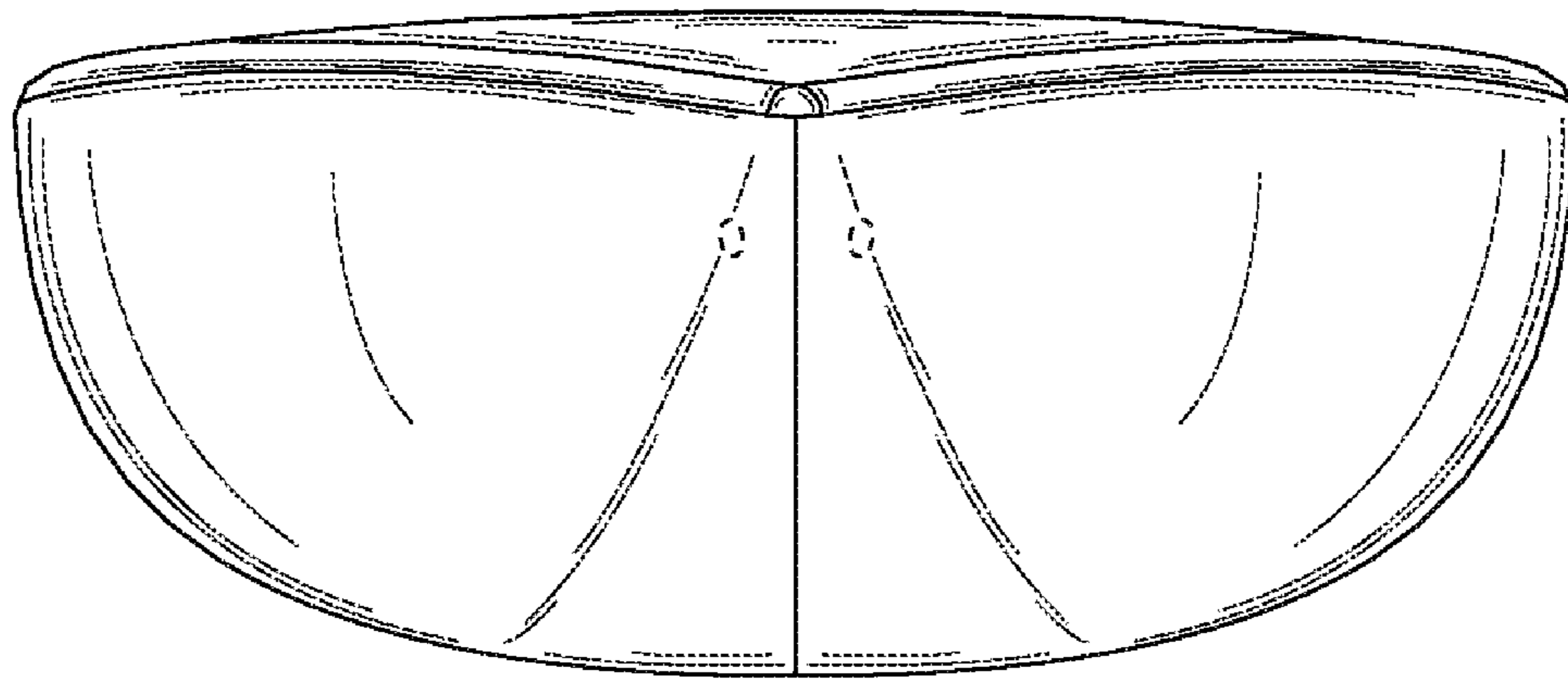

Fig. 2

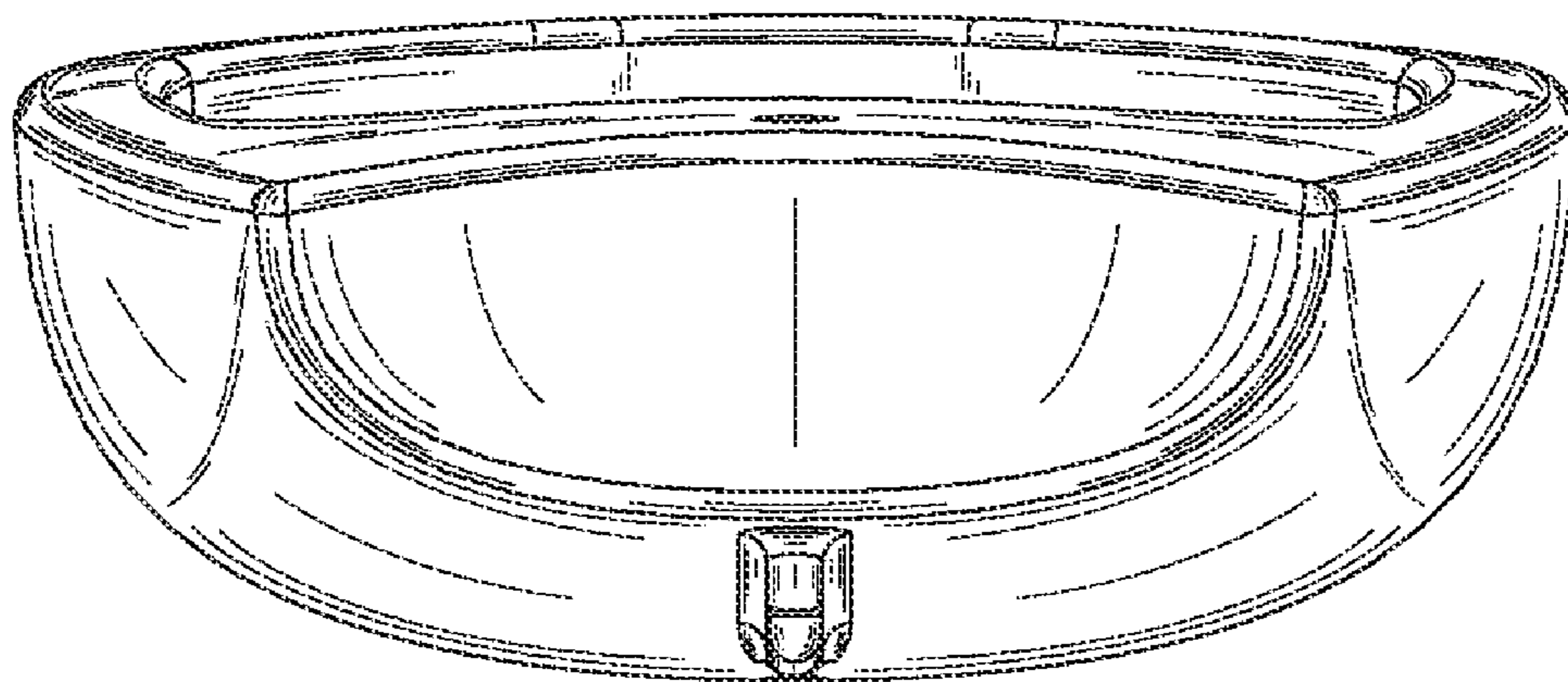

Fig. 3

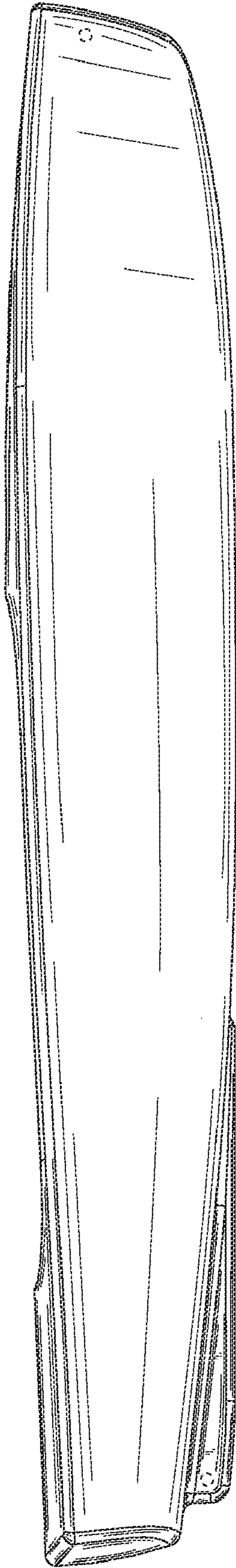

Fig. 4

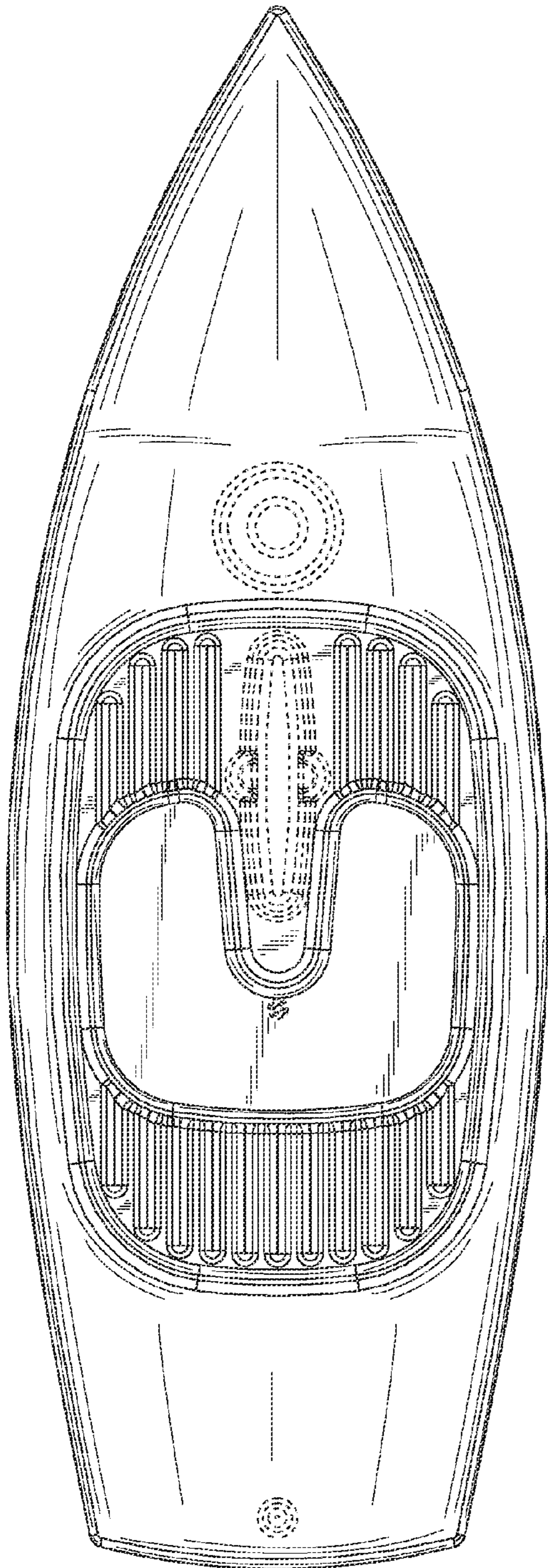

Fig. 5

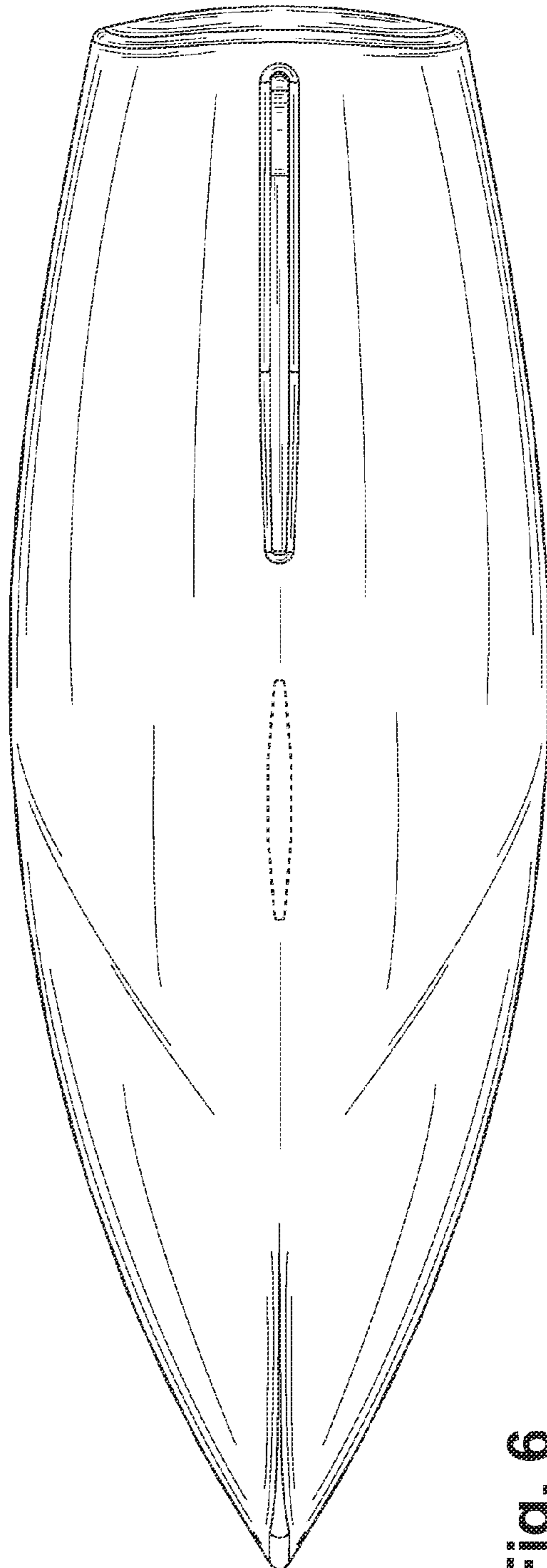

Fig. 6