

US00D564033S

(12) **United States Design Patent**  
**Itskov et al.**

(10) **Patent No.:** **US D564,033 S**

(45) **Date of Patent:** **\*\* Mar. 11, 2008**

(54) **VIDEO GAME TERMINAL**

(75) Inventors: **Boris Itskov**, Thornhill (CA); **Igor Starovoitov**, Toronto (CA)

(73) Assignee: **JVL Corporation**, Concord, ON (CA)

(\*\*) Term: **14 Years**

(21) Appl. No.: **29/265,983**

(22) Filed: **Sep. 13, 2006**

(51) **LOC (8) Cl.** ..... **21-01**

(52) **U.S. Cl.** ..... **D21/329**

(58) **Field of Classification Search** ..... D21/324-333,  
D21/369; 273/148 B, 148 R, 138.1, 459-461;  
463/1, 29-35, 43-47; 345/156, 905; D14/496,  
D14/125, 126, 100; 700/1, 2, 9  
See application file for complete search history.

(56) **References Cited**

**U.S. PATENT DOCUMENTS**

4,536,164	A *	8/1985	Klawitter	.....	446/143
4,752,069	A *	6/1988	Okada	.....	463/23
D331,079	S *	11/1992	Duhamel	.....	D21/325
D334,414	S *	3/1993	Kitae	.....	D21/331

5,213,327	A *	5/1993	Kitae	.....	463/38
D346,408	S *	4/1994	Lee	.....	D21/330
D358,430	S *	5/1995	Rissman et al.	.....	D21/329
D359,516	S *	6/1995	Brettschneider	.....	D21/325
5,611,731	A *	3/1997	Bouton et al.	.....	463/37
D395,458	S *	6/1998	Smith et al.	.....	D21/329
D410,499	S *	6/1999	Smith et al.	.....	D21/329

\* cited by examiner

*Primary Examiner*—Prabhakar Deshmukh

(57) **CLAIM**

An ornamental design for a video game terminal, as shown.

**DESCRIPTION**

FIG. 1 is a front perspective of the video game terminal;  
FIG. 2 is a front view of the video game terminal;  
FIG. 3 is a left side view of the video game terminal;  
FIG. 4 is right side view of the video game terminal;  
FIG. 5 is a rear view of the video game terminal;  
FIG. 6 is a top view of the video game terminal; and,  
FIG. 7 is a bottom view of the video game terminal.

**1 Claim, 7 Drawing Sheets**

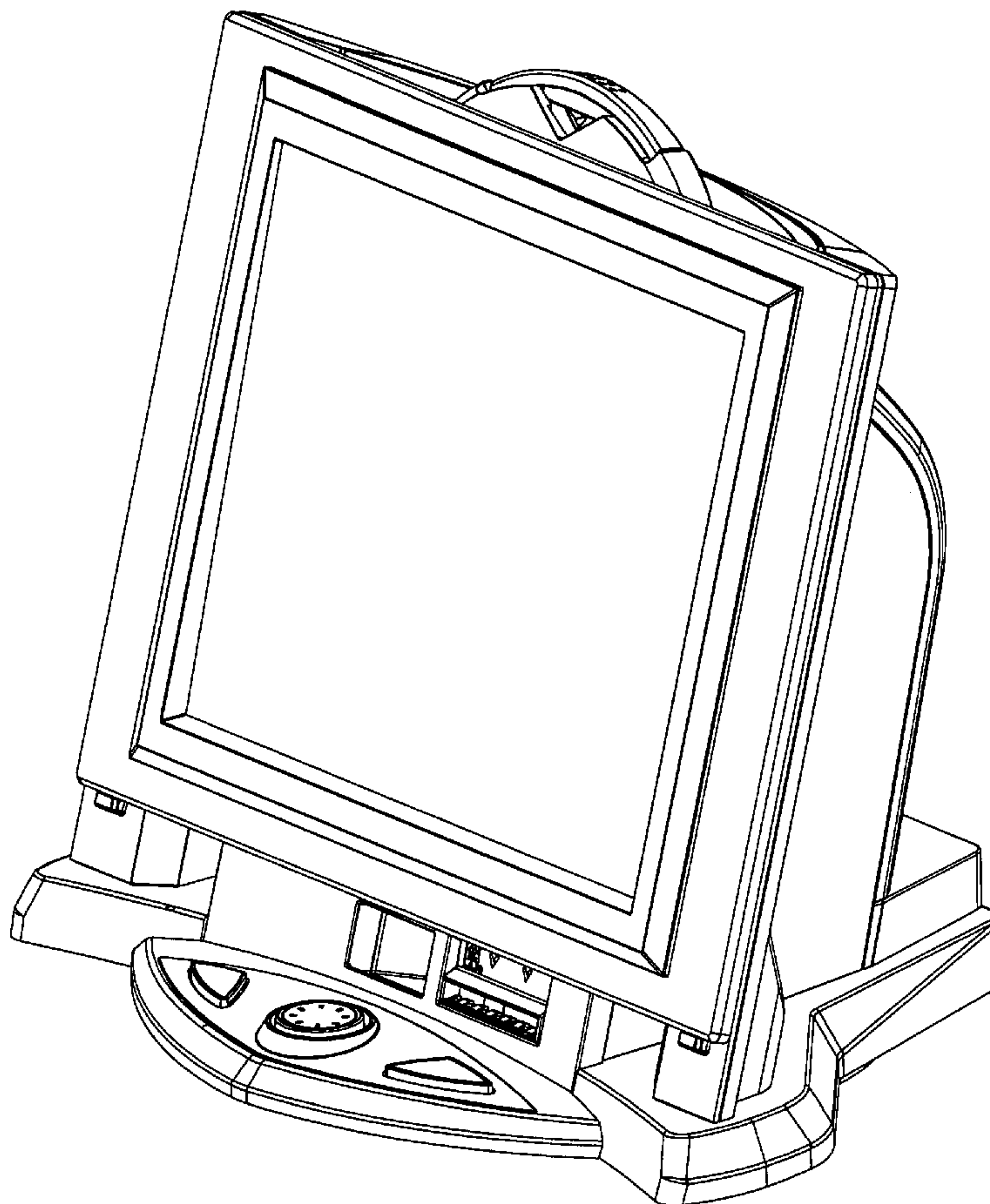

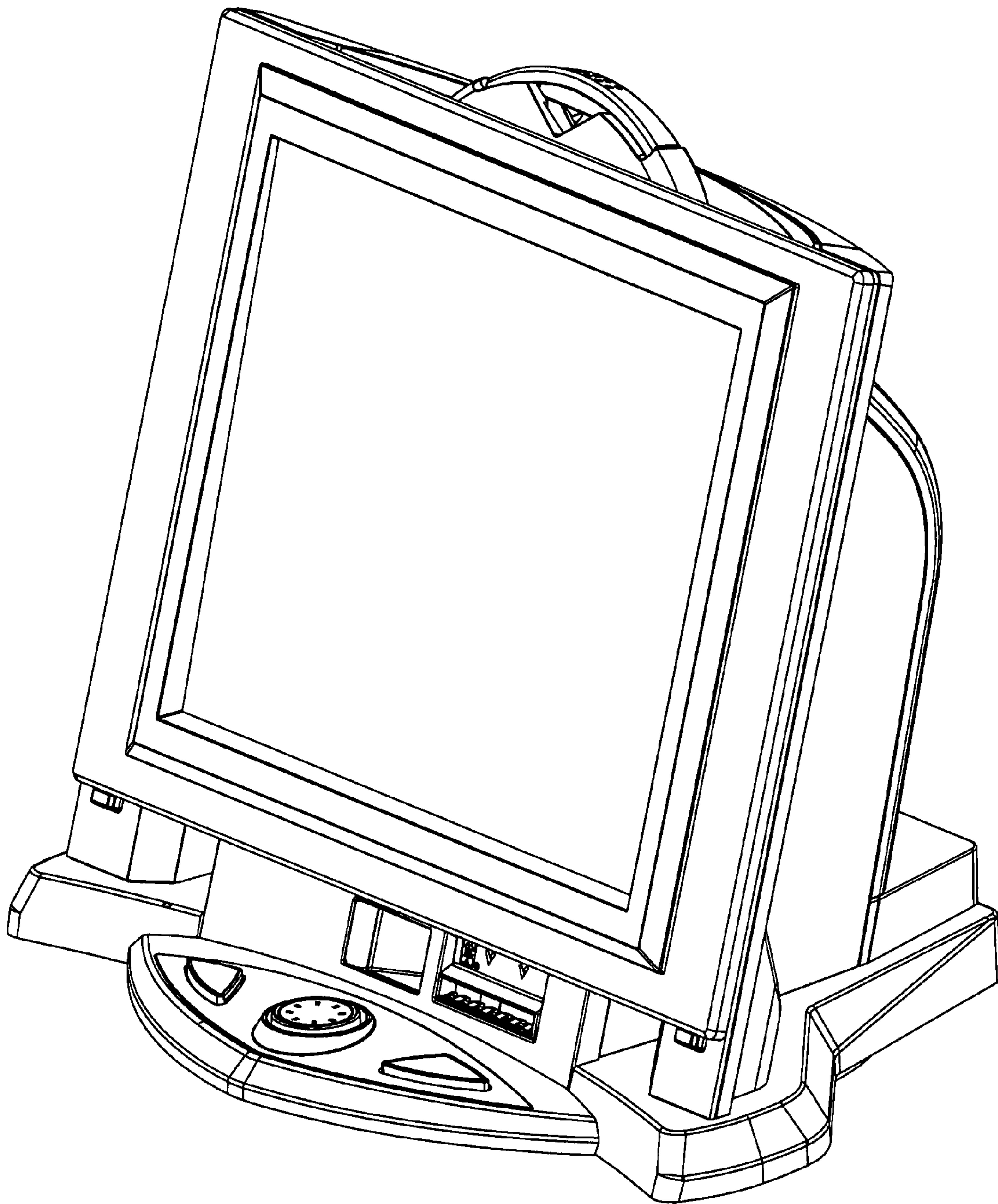

FIG. 1

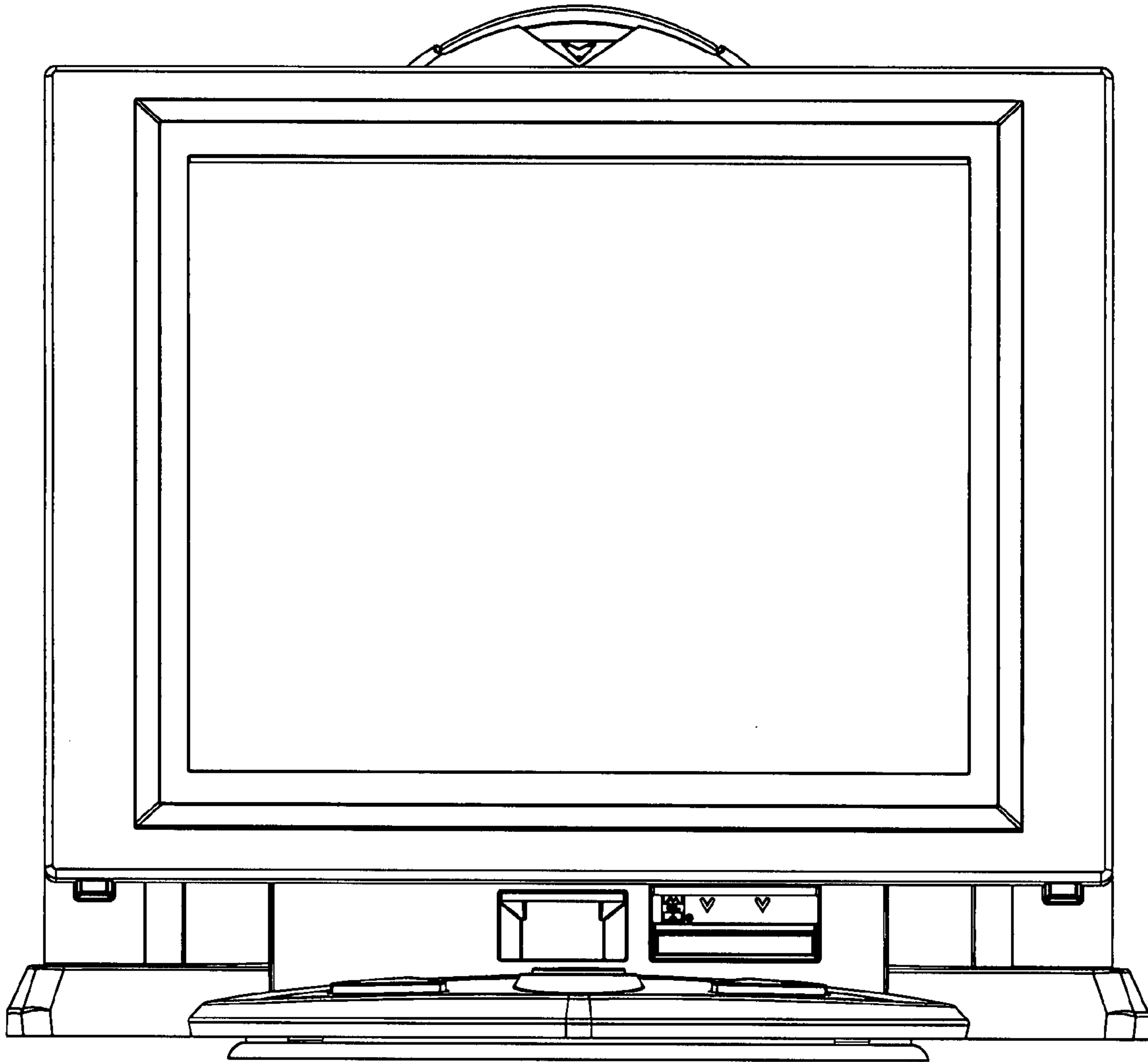

FIG. 2

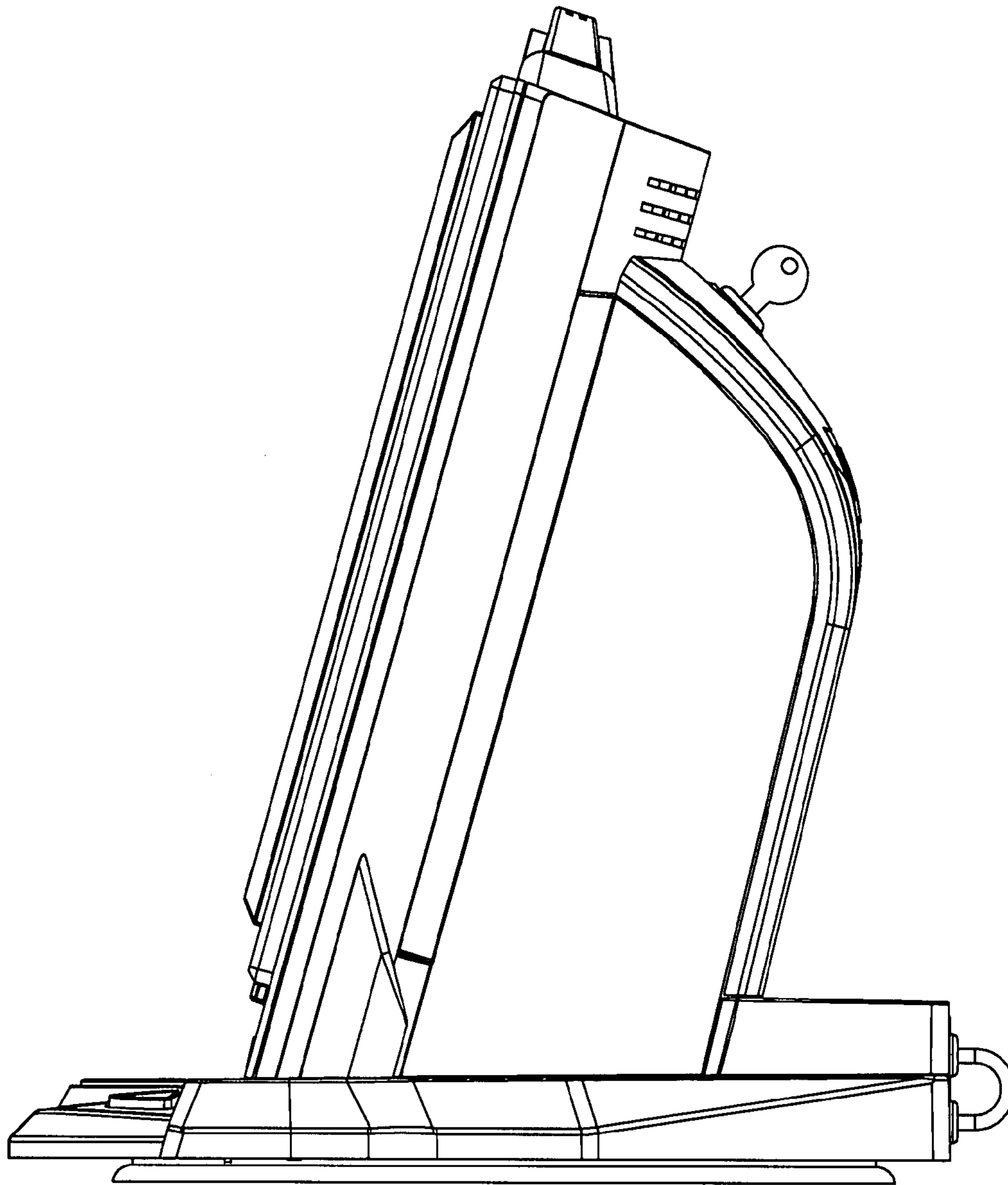

FIG. 3

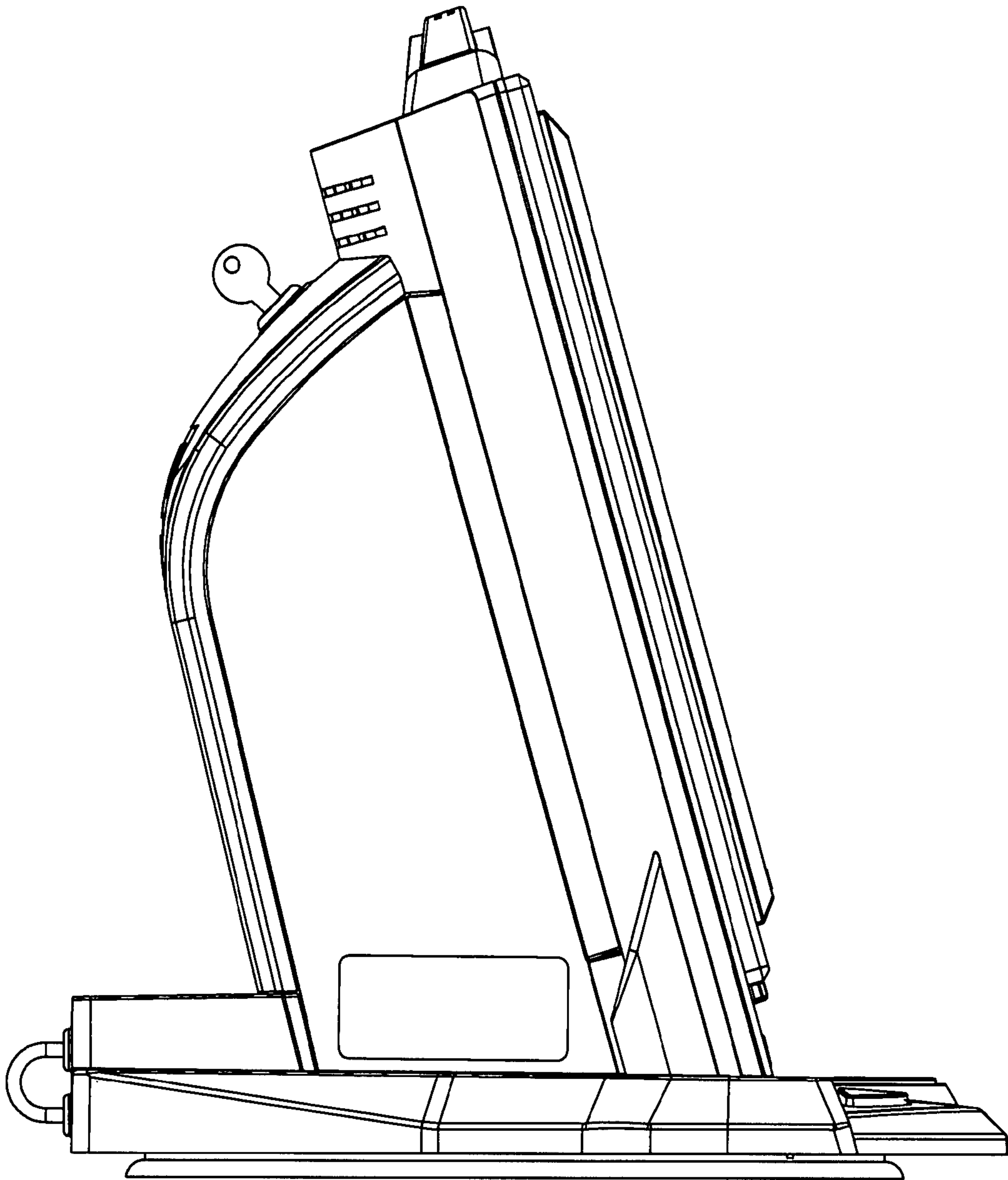

FIG. 4



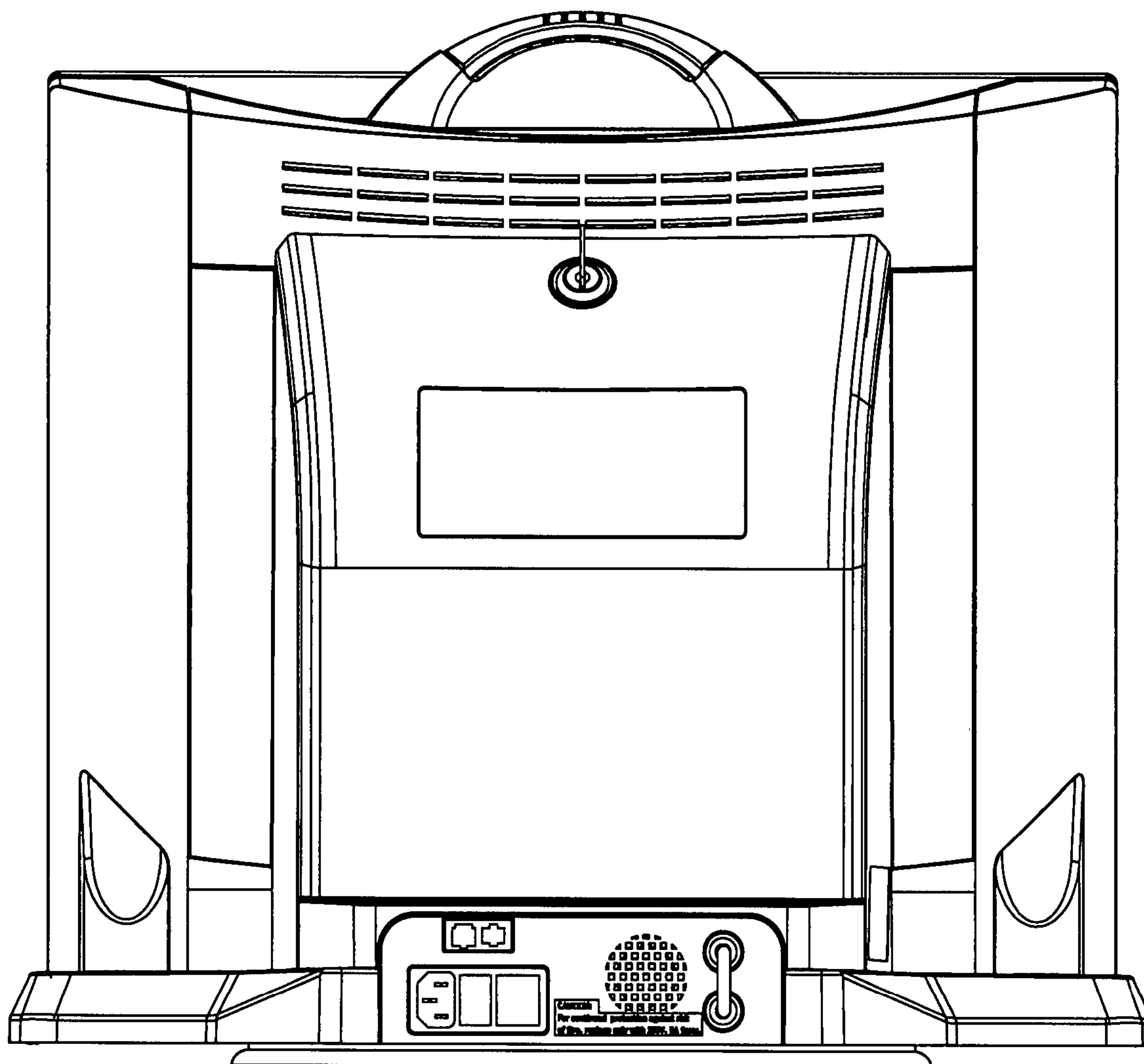

FIG. 5

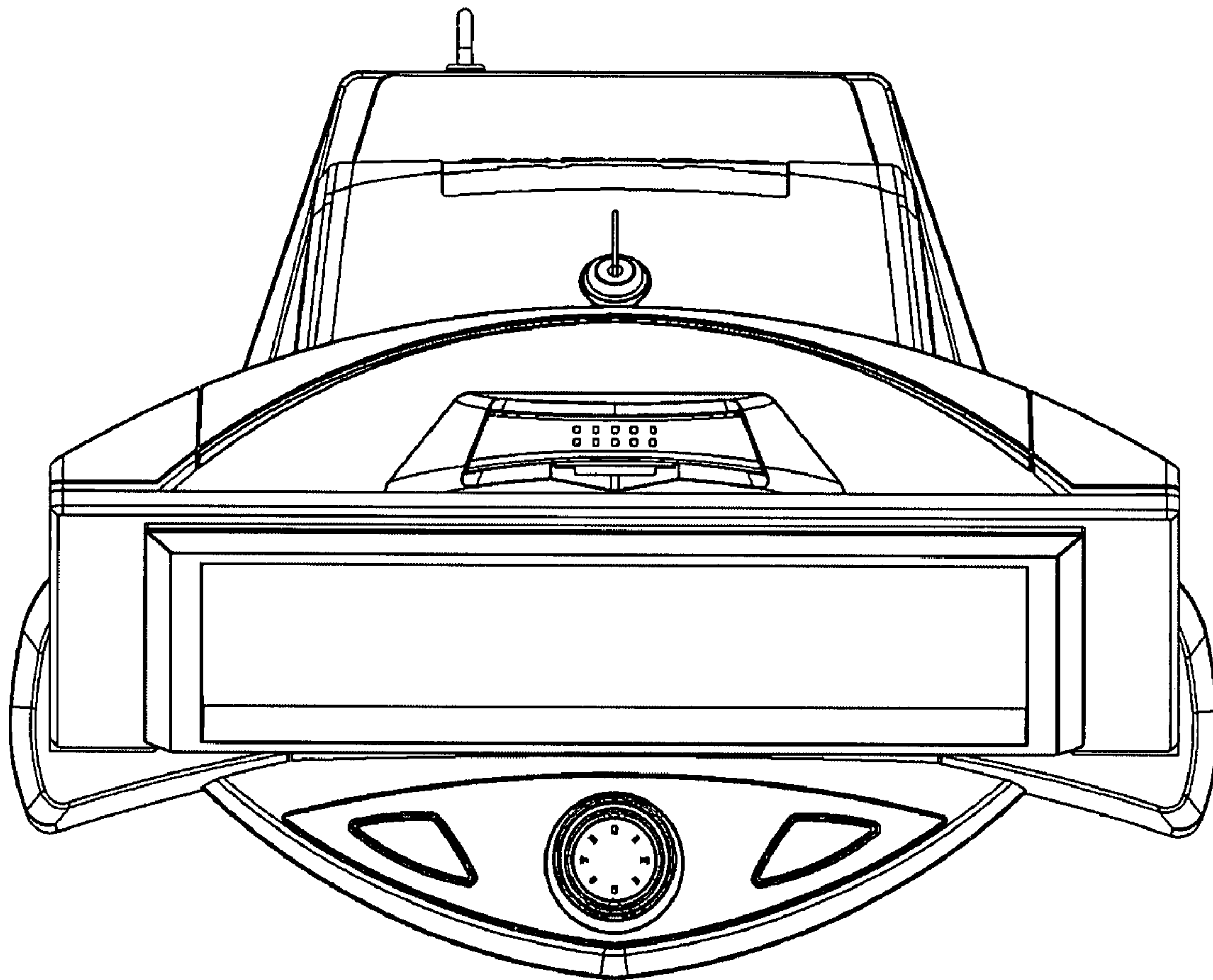

FIG. 6

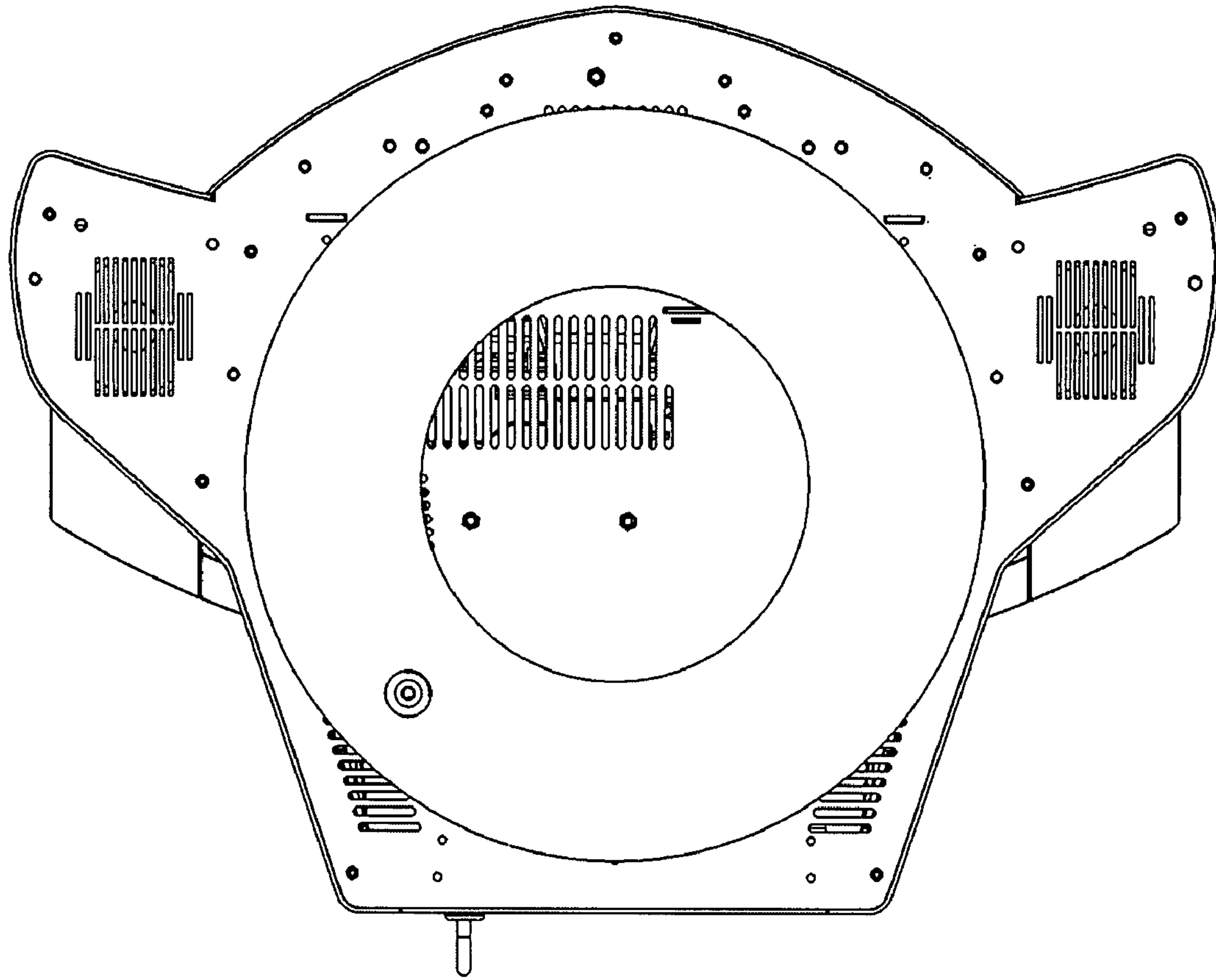

FIG. 7