



US00D563943S

(12) **United States Design Patent**  
**Watanabe**

(10) **Patent No.:** **US D563,943 S**

(45) **Date of Patent:** **\*\* Mar. 11, 2008**

(54) **AUDIO INTERFACE**

D479,847 S \* 9/2003 Wang ..... D14/496  
D489,726 S \* 5/2004 Takita et al. .... D14/433  
D512,971 S \* 12/2005 Chen ..... D14/129

(75) Inventor: **Hiroyuki Watanabe**, Tokyo (JP)

(73) Assignee: **TEAC Corporation**, Musashino-Shi,  
Tokyo (JP)

\* cited by examiner

(\*\*) Term: **14 Years**

*Primary Examiner*—Stella M. Reid

*Assistant Examiner*—Keli' L. Acker

(74) *Attorney, Agent, or Firm*—Manabu Kanesaka

(21) Appl. No.: **29/266,740**

(22) Filed: **Sep. 28, 2006**

(57) **CLAIM**

The ornamental design for an audio interface, as shown and described.

(30) **Foreign Application Priority Data**

Apr. 7, 2006 (JP) ..... 2006-008982

**DESCRIPTION**

(51) **LOC (8) Cl.** ..... **14-02**

(52) **U.S. Cl.** ..... **D14/188**; D14/433; D14/435

(58) **Field of Classification Search** ..... D14/135,  
D14/136, 188, 193–198, 217, 432–438; D13/133,  
D13/146, 147; 340/384.1, 825.22, 825.24,  
340/825.25; 361/686; 439/299–300

See application file for complete search history.

FIG. 1 is a perspective view of an audio interface showing my new design;

FIG. 2 is a top plan view thereof;

FIG. 3 is a front view thereof;

FIG. 4 is a bottom view thereof;

FIG. 5 is a rear view thereof;

FIG. 6 is a left side view thereof; and,

FIG. 7 is a right side view thereof.

The broken line showing of the audio interface is included for the purpose of illustrating environmental structure and forms no part of the claimed design.

(56) **References Cited**

**U.S. PATENT DOCUMENTS**

D259,789 S \* 7/1981 Watanabe ..... D14/197  
D313,024 S \* 12/1990 Richards et al. .... D14/265  
D426,225 S \* 6/2000 Davis ..... D14/188  
D427,193 S \* 6/2000 Fedele ..... D14/348  
D443,259 S \* 6/2001 Okubo ..... D14/167

**1 Claim, 4 Drawing Sheets**

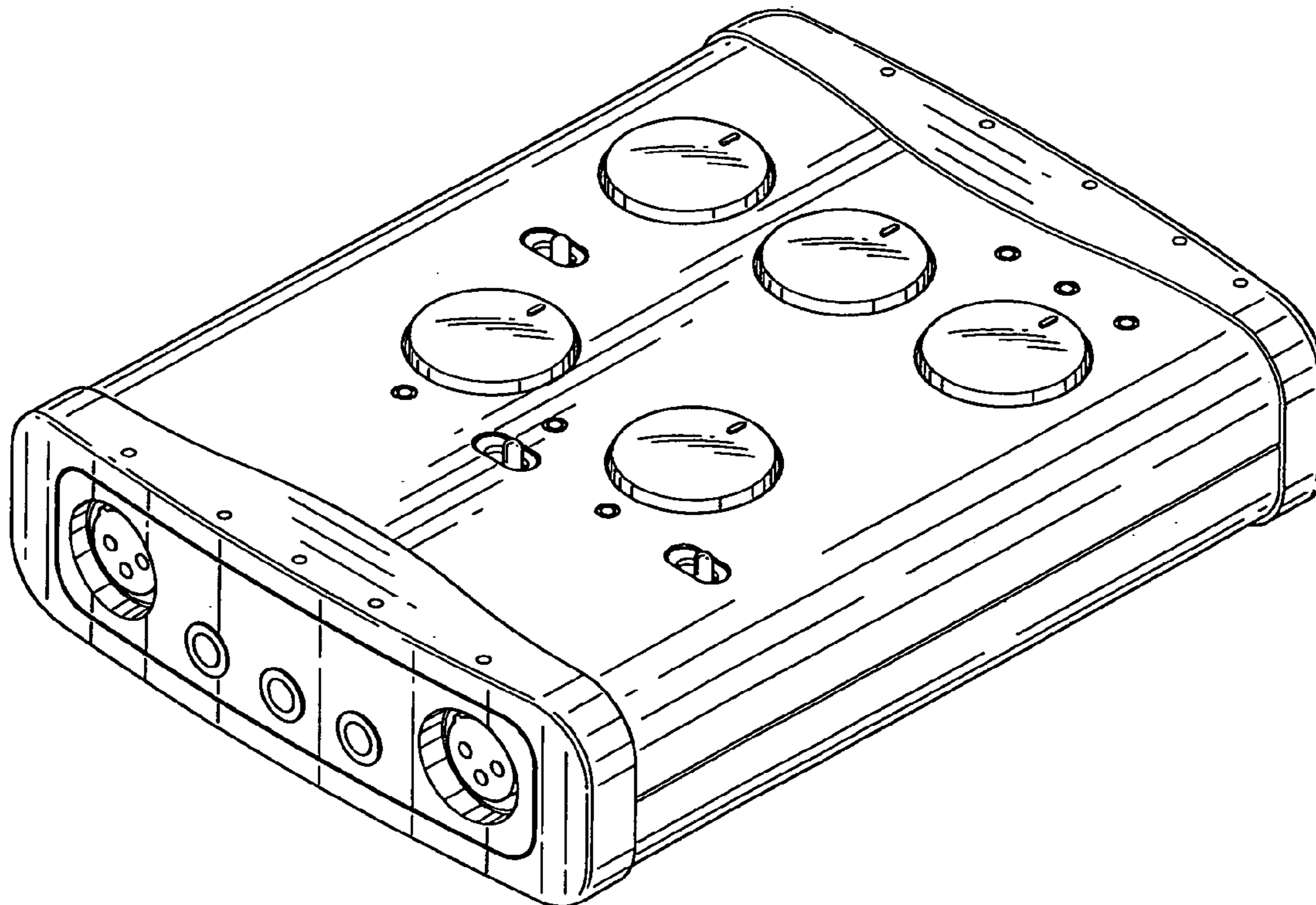

FIG. 1

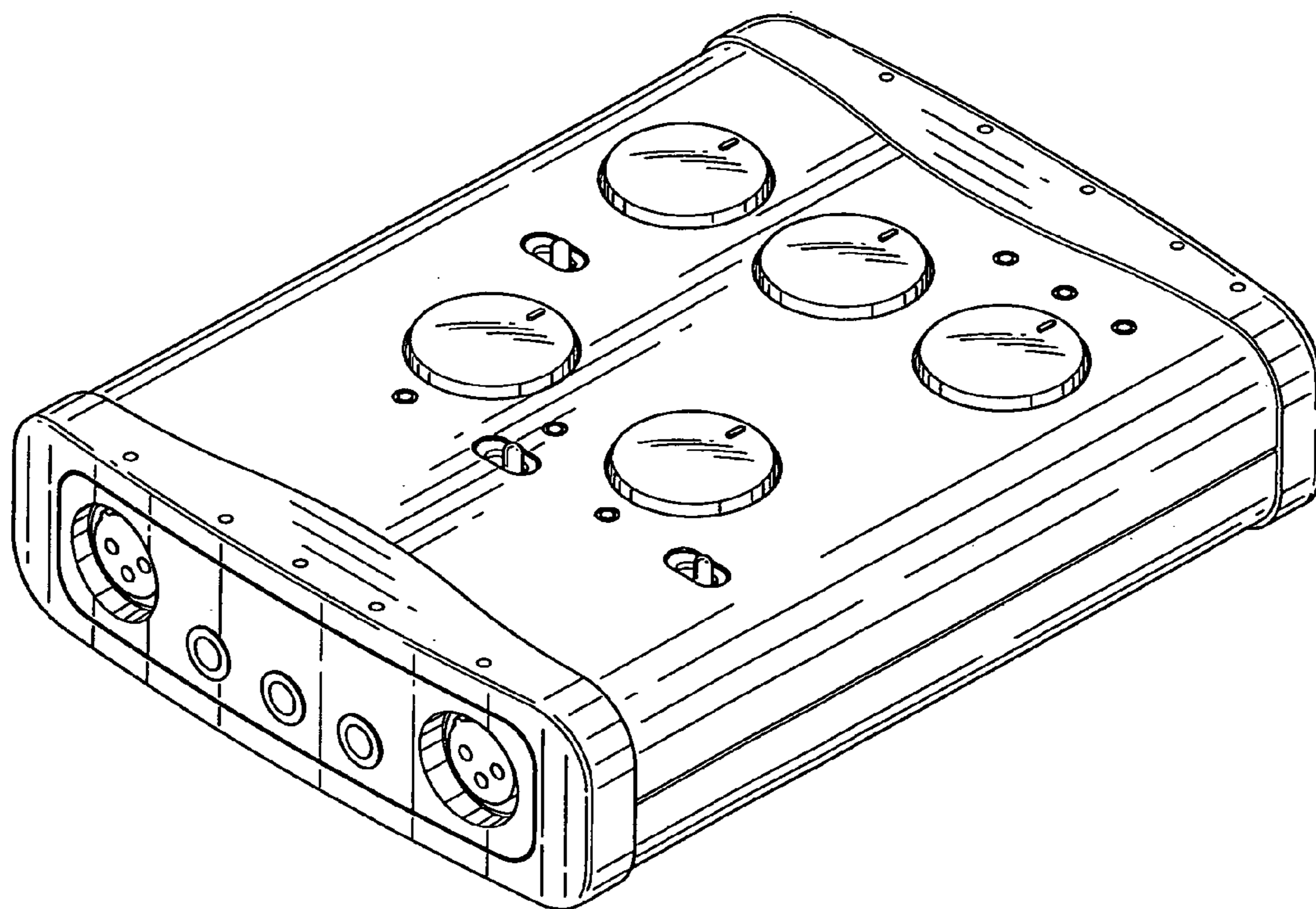

FIG. 2

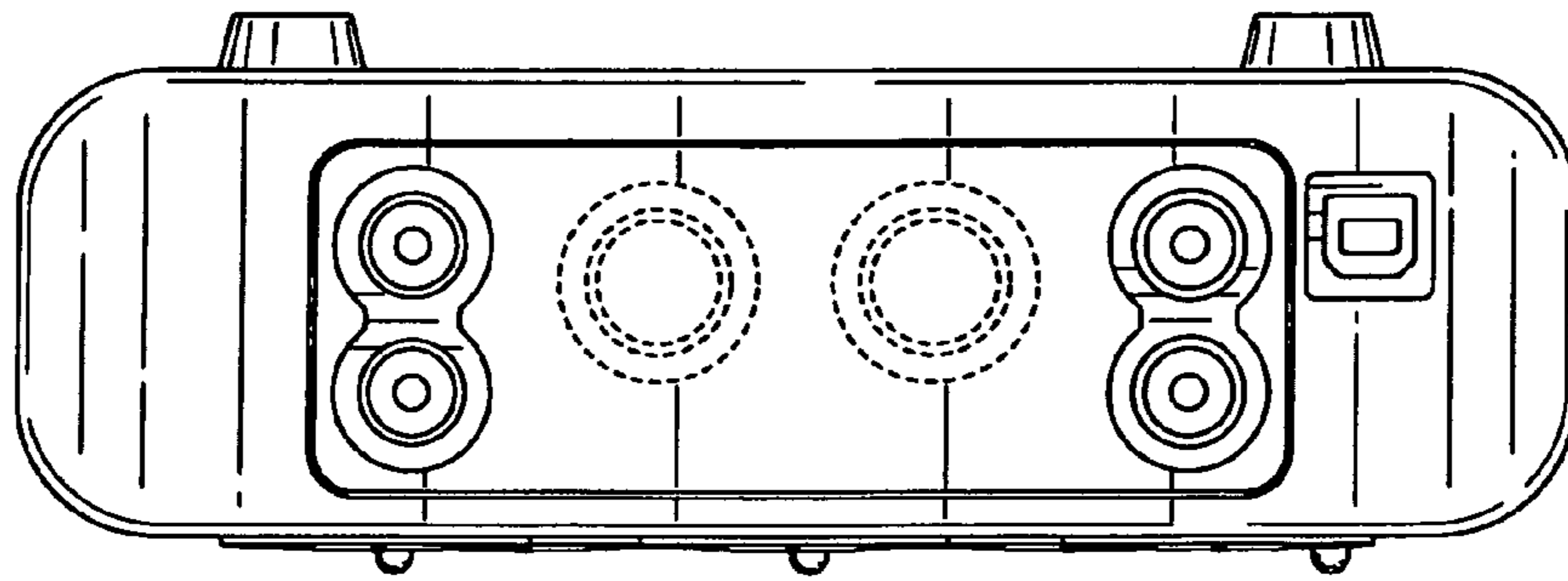

FIG. 3

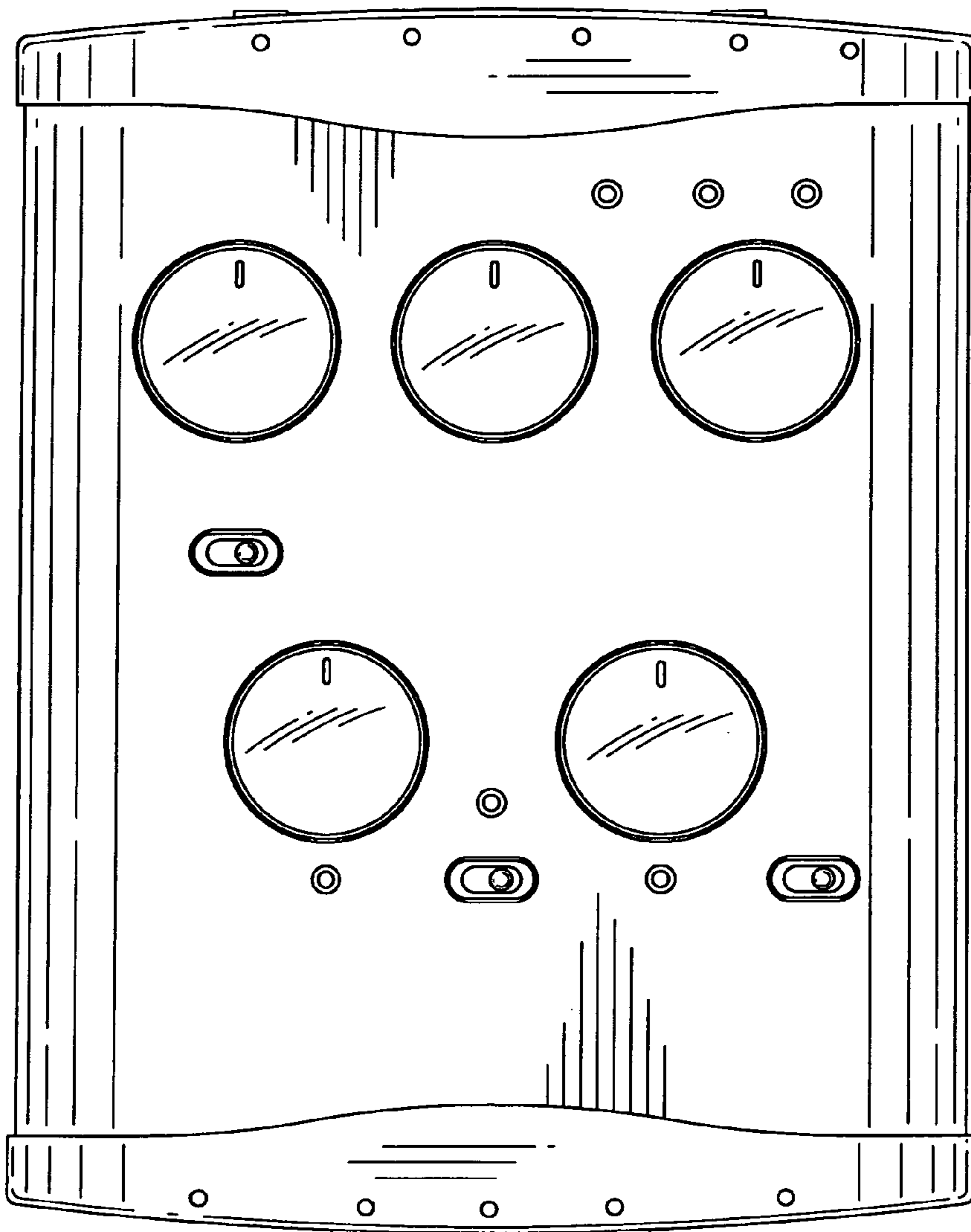

FIG. 4

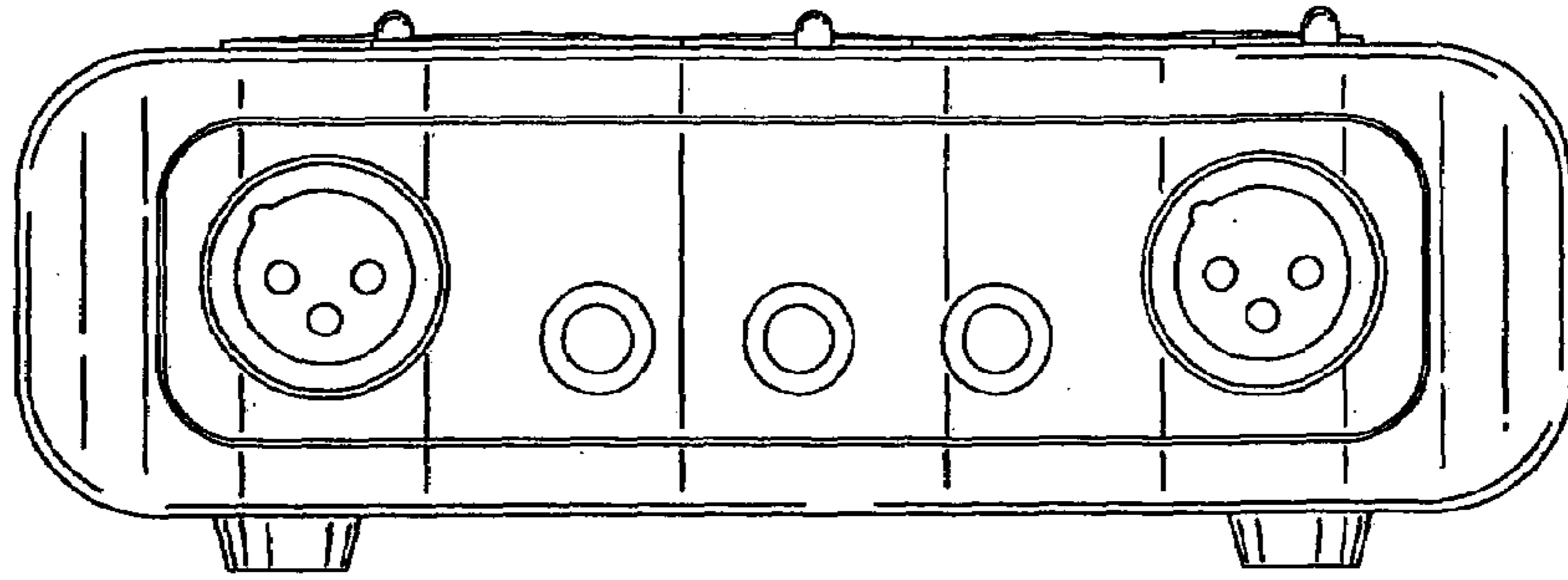

FIG. 5

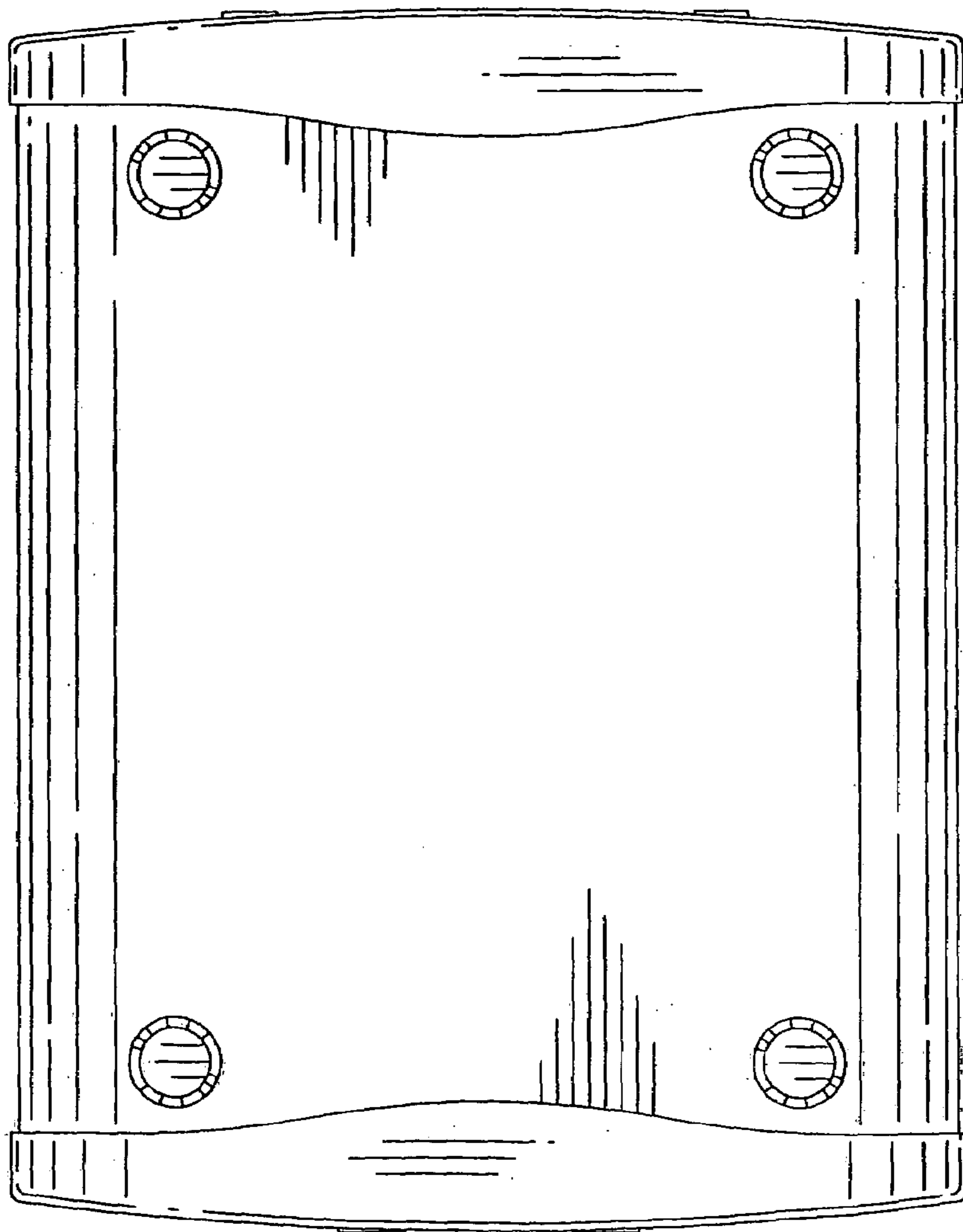

FIG. 6

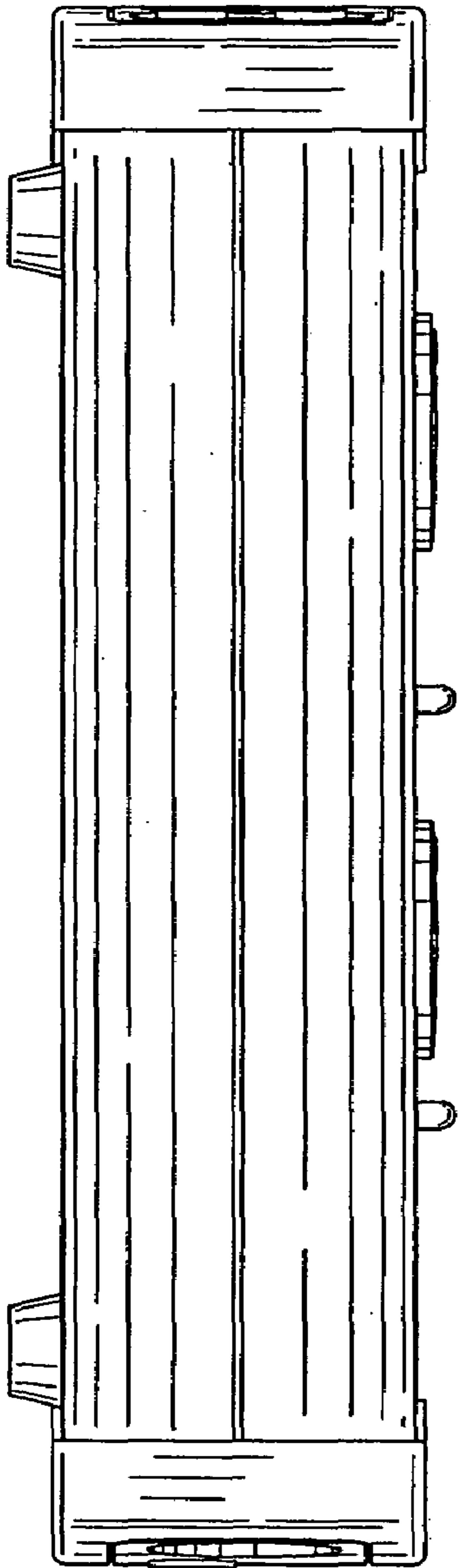

FIG. 7

