

US00D563860S

(12) **United States Design Patent**  
**Roberts et al.**

(10) **Patent No.:** **US D563,860 S**  
(45) **Date of Patent:** **\*\* Mar. 11, 2008**

(54) **BOAT**

D324,367 S \* 3/1992 Hart et al. .... D12/314  
D329,038 S \* 9/1992 Dekker et al. .... D12/314

(75) Inventors: **Edward Roberts**, Newport, RI (US);  
**Ward Setzer**, Cary, NC (US)

\* cited by examiner

(73) Assignee: **The Talaria Company LLC**,  
Portsmouth, RI (US)

*Primary Examiner*—Holly H. Baynham

*Assistant Examiner*—Cynthia M. Chin

(74) *Attorney, Agent, or Firm*—Goodwin Procter LLP

(\*\*) Term: **14 Years**

(57) **CLAIM**

(21) Appl. No.: **29/264,065**

The ornamental design for a boat, as shown and described.

(22) Filed: **Aug. 2, 2006**

**DESCRIPTION**

(51) **LOC (8) Cl.** ..... **12-06**

(52) **U.S. Cl.** ..... **D12/300**

(58) **Field of Classification Search** ..... D12/300,  
D12/310–318; D21/542; 114/364, 343,  
114/56.1, 61.32, 61.33, 63

See application file for complete search history.

FIG. 1 is a perspective view of a new design for a boat;

FIG. 2 is a top plan view of the boat of FIG. 1;

FIG. 3 is a front elevation view of the boat of FIG. 1;

FIG. 4 is a rear elevation view of the bottle of FIG. 1;

FIG. 5 is a left side view of the boat of FIG. 1; and,

FIG. 6 is a right side view of the boat of FIG. 1.

The broken lines immediately adjacent the shaded areas represent the bounds of the claim and all other broken lines are for illustrative purposes only. None of the broken lines form a part of the claimed design.

(56) **References Cited**

U.S. PATENT DOCUMENTS

D219,118 S \* 11/1970 Baken ..... D12/300  
3,783,461 A \* 1/1974 Sugden ..... 114/361  
D261,128 S \* 10/1981 Fowler ..... D12/300  
D322,240 S \* 12/1991 Carlson ..... D12/300

**1 Claim, 6 Drawing Sheets**

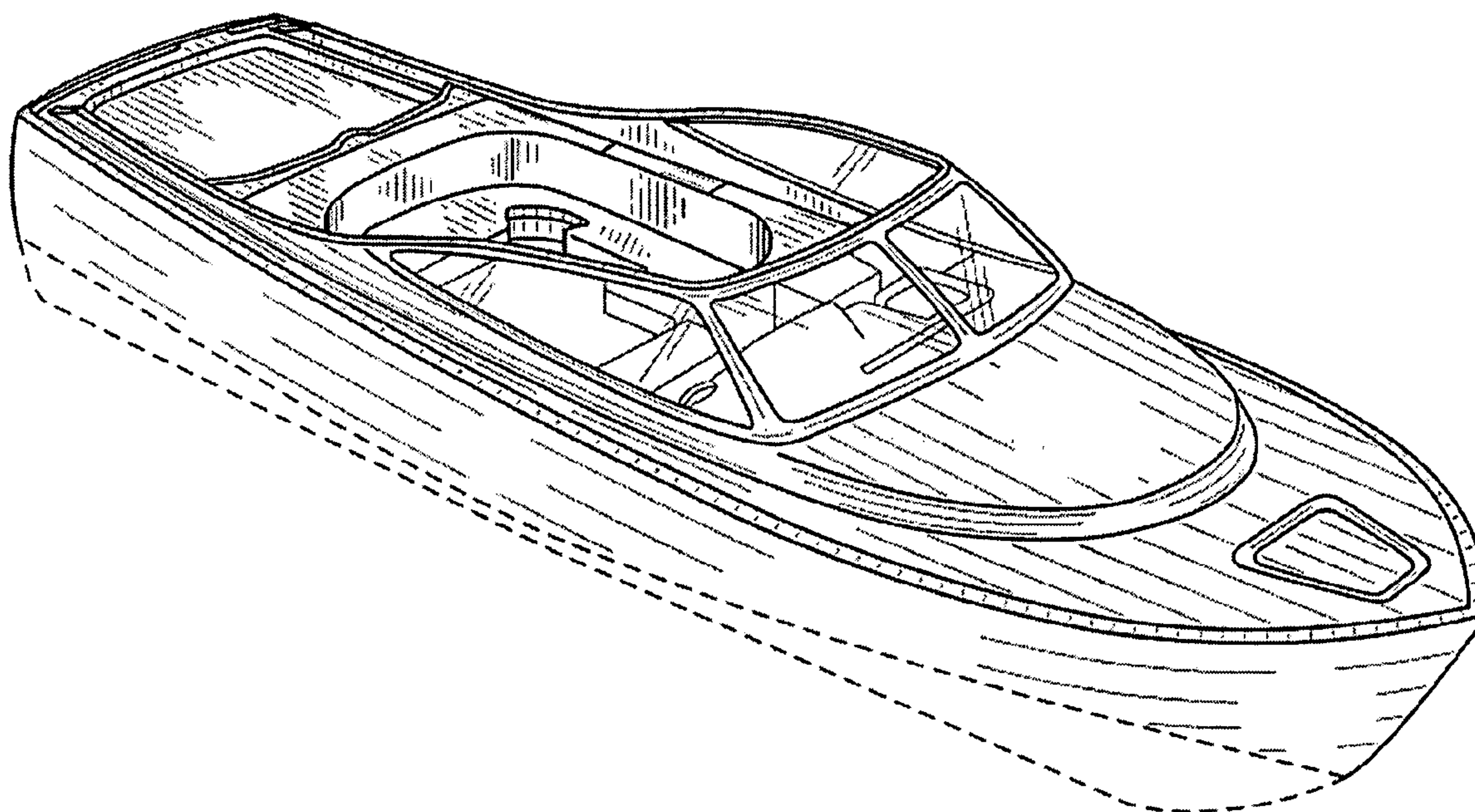

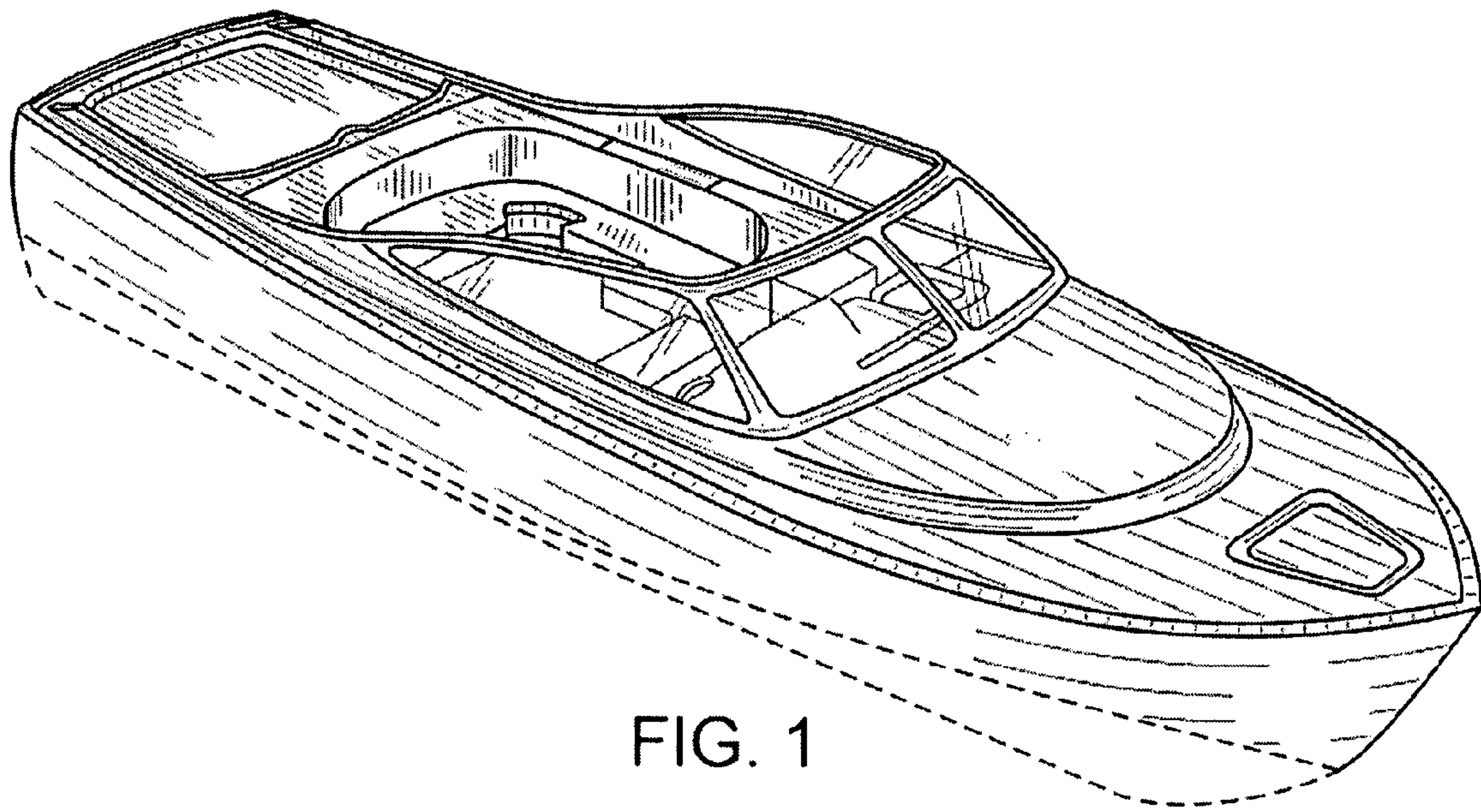

FIG. 1

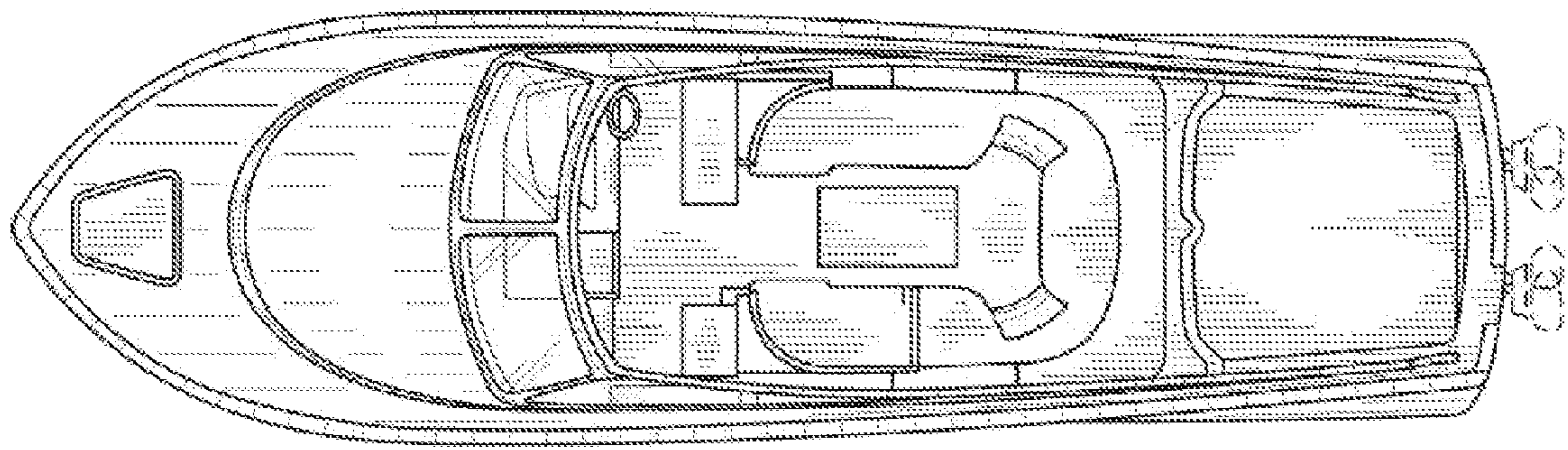

FIG. 2



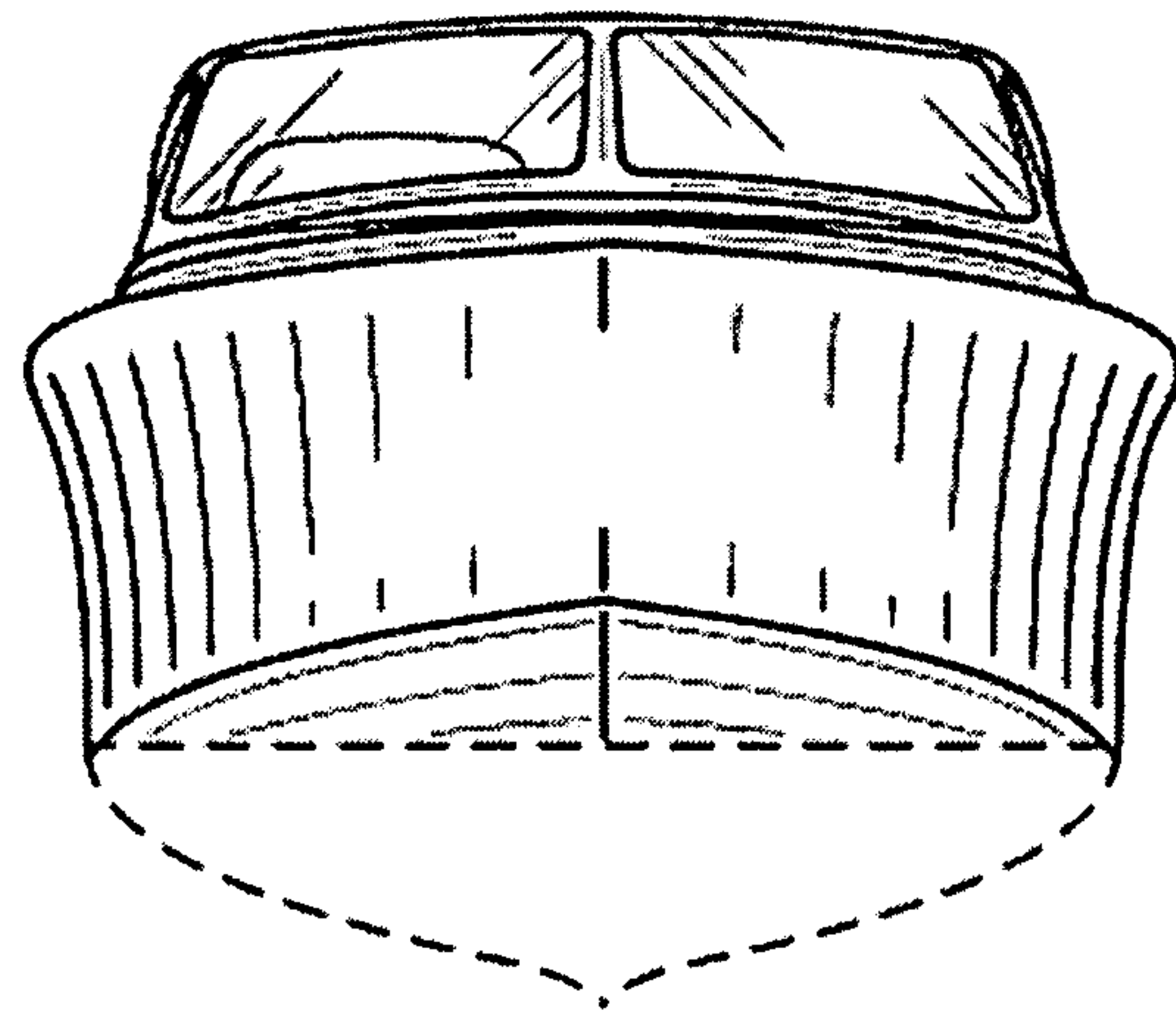

FIG. 3

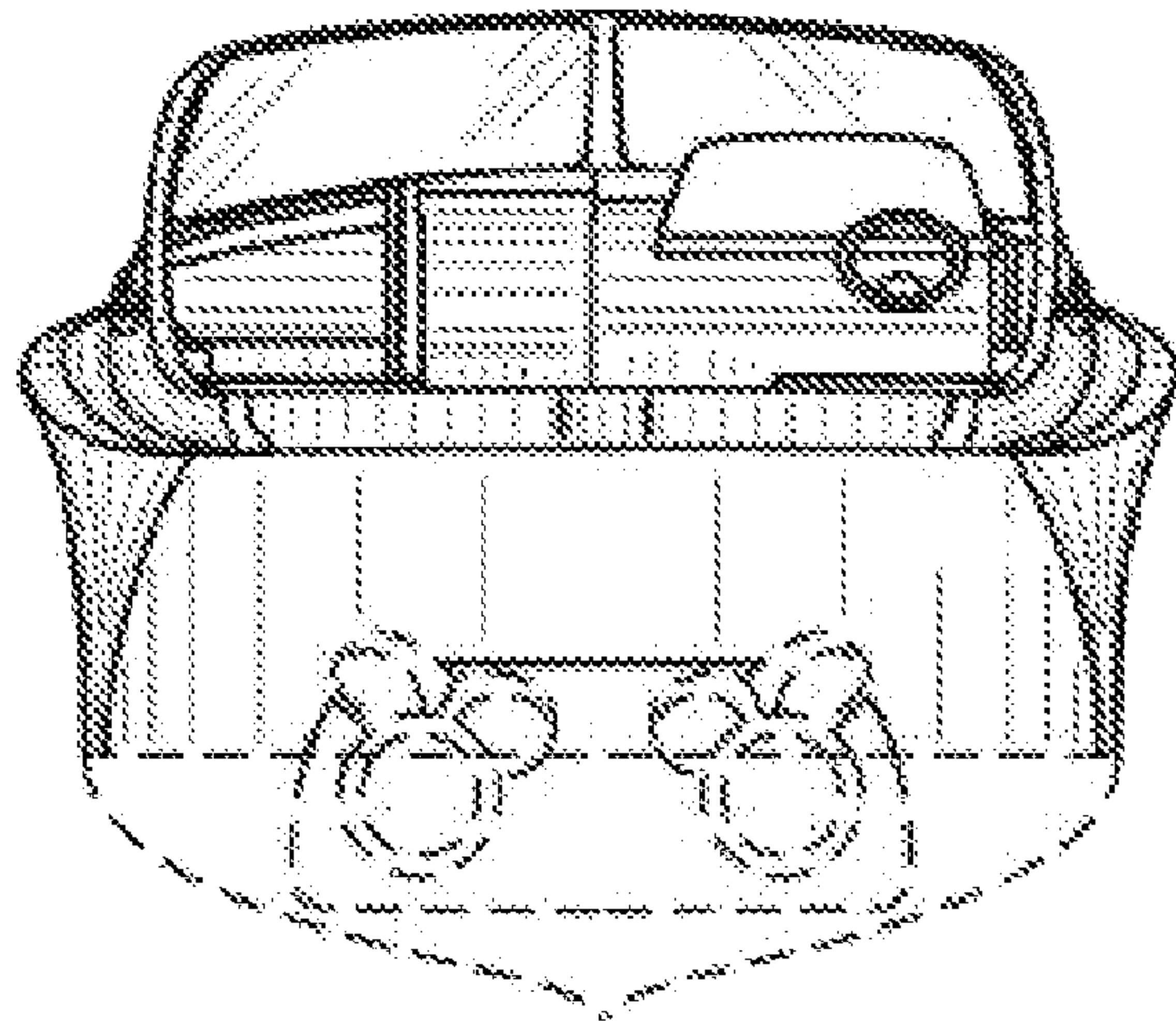

FIG. 4

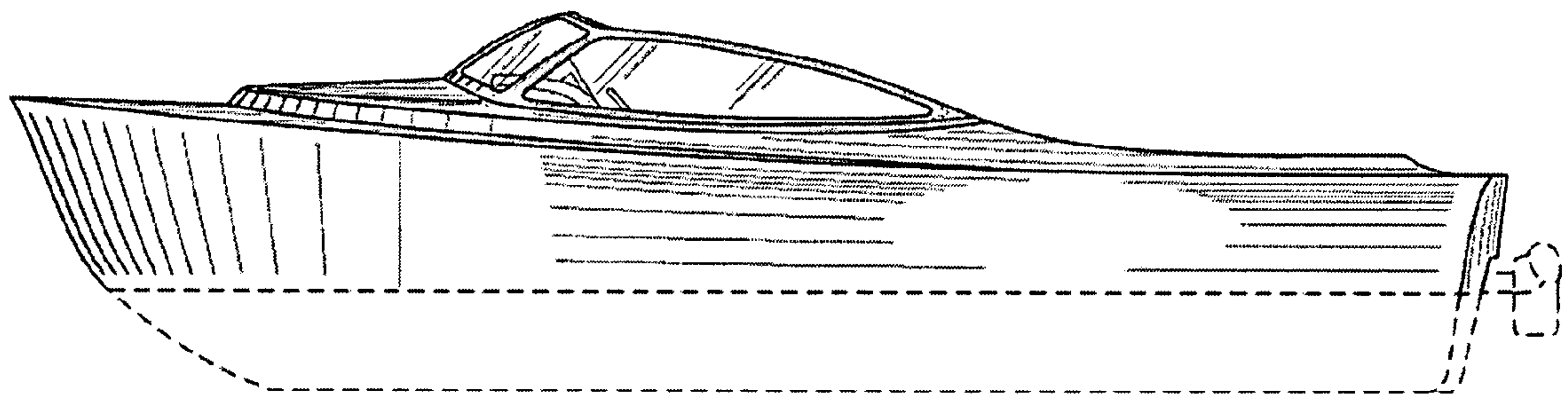

FIG. 5

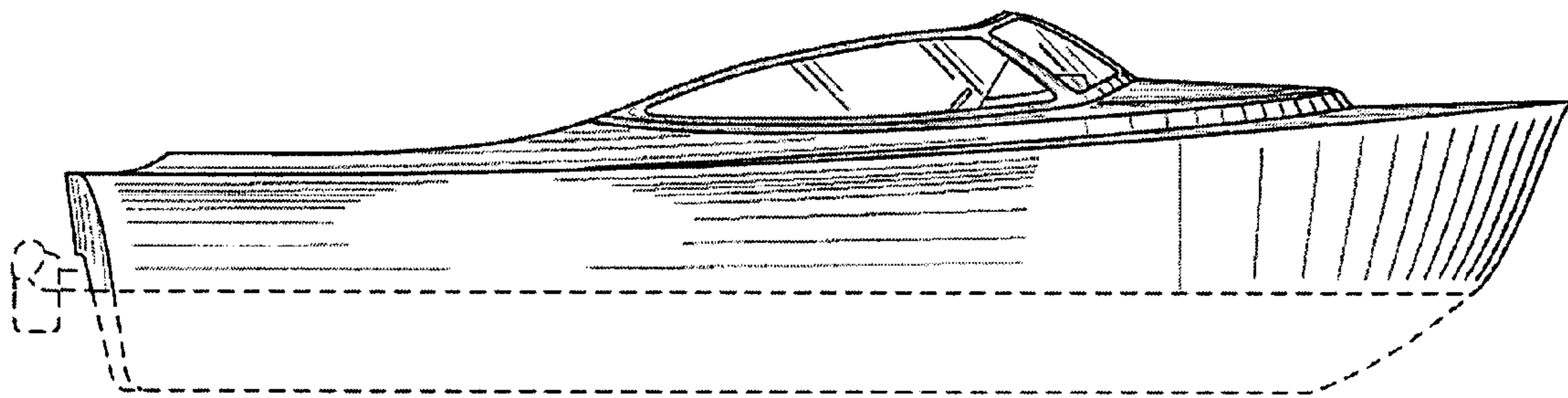

FIG. 6