



US00D563852S

(12) **United States Design Patent**  
**Rosen et al.**

(10) **Patent No.:** **US D563,852 S**  
(45) **Date of Patent:** **\*\* Mar. 11, 2008**

(54) **TRUCK HOOD**

(75) Inventors: **David B. Rosen**, Flower Mound, TX (US); **Aaron M. Elliott**, Denton, TX (US); **Louis D. Heilaneh**, Lewisville, TX (US); **Bryan W. Delashaw**, Frisco, TX (US)

D401,198 S 11/1998 Mueller  
D403,636 S 1/1999 Meryman  
D405,037 S 2/1999 Meryman  
D411,140 S 6/1999 Meryman  
D411,494 S 6/1999 Meryman  
D412,689 S 8/1999 Onopa  
D412,874 S 8/1999 Meryman

(73) Assignee: **PACCAR Inc**, Bellevue, WA (US)

(Continued)

(\*\*) Term: **14 Years**

**OTHER PUBLICATIONS**

(21) Appl. No.: **29/278,176**

Kenworth Truck Company W900 brochure, Kirkland, Wash., 2005.

(22) Filed: **Mar. 21, 2007**

(Continued)

(51) **LOC (8) Cl.** ..... **12-16**

*Primary Examiner*—Melody N. Brown

(52) **U.S. Cl.** ..... **D12/173**

(74) *Attorney, Agent, or Firm*—Christensen O'Connor Johnson Kindness PLLC

(58) **Field of Classification Search** ..... D12/173,  
D12/96, 90-92; 180/69.2, 69.21, 69.22,  
180/69.25

(57) **CLAIM**

See application file for complete search history.

The ornamental design for a truck hood, as shown and described.

(56) **References Cited**

**DESCRIPTION**

**U.S. PATENT DOCUMENTS**

D291,872 S 9/1987 Simons  
D291,982 S 9/1987 Simons  
D307,731 S 5/1990 Kerney  
D308,032 S 5/1990 Kerney  
D311,711 S 10/1990 Marlowe  
D312,805 S 12/1990 Marlowe  
D313,784 S 1/1991 Marlowe  
D313,966 S 1/1991 Marlowe  
D320,583 S 10/1991 Simons  
D327,276 S 6/1992 Sorensen  
D329,214 S 9/1992 Marlowe  
D361,968 S 9/1995 Oyama  
D366,638 S 1/1996 Tucker  
D366,640 S 1/1996 Tucker  
D382,841 S 8/1997 Norwood  
D382,844 S 8/1997 Norwood  
D384,019 S 9/1997 Meryman  
D389,108 S 1/1998 Norwood  
D395,860 S 7/1998 Meryman  
D400,835 S 11/1998 Le Quement

FIG. 1 is a front perspective view of a truck hood showing our new design;  
FIG. 2 is a top plan view of the truck hood of FIG. 1;  
FIG. 3 is a bottom plan view of the truck hood of FIG. 1;  
FIG. 4 is a front elevational view of the truck hood of FIG. 1;  
FIG. 5 is a rear elevational view of the truck hood of FIG. 1;  
FIG. 6 is a left side elevational view of the truck hood of FIG. 1; and,  
FIG. 7 is a right side elevational view of the truck hood of FIG. 1.  
The broken lines in the drawings form no part of the claimed design.

**1 Claim, 5 Drawing Sheets**

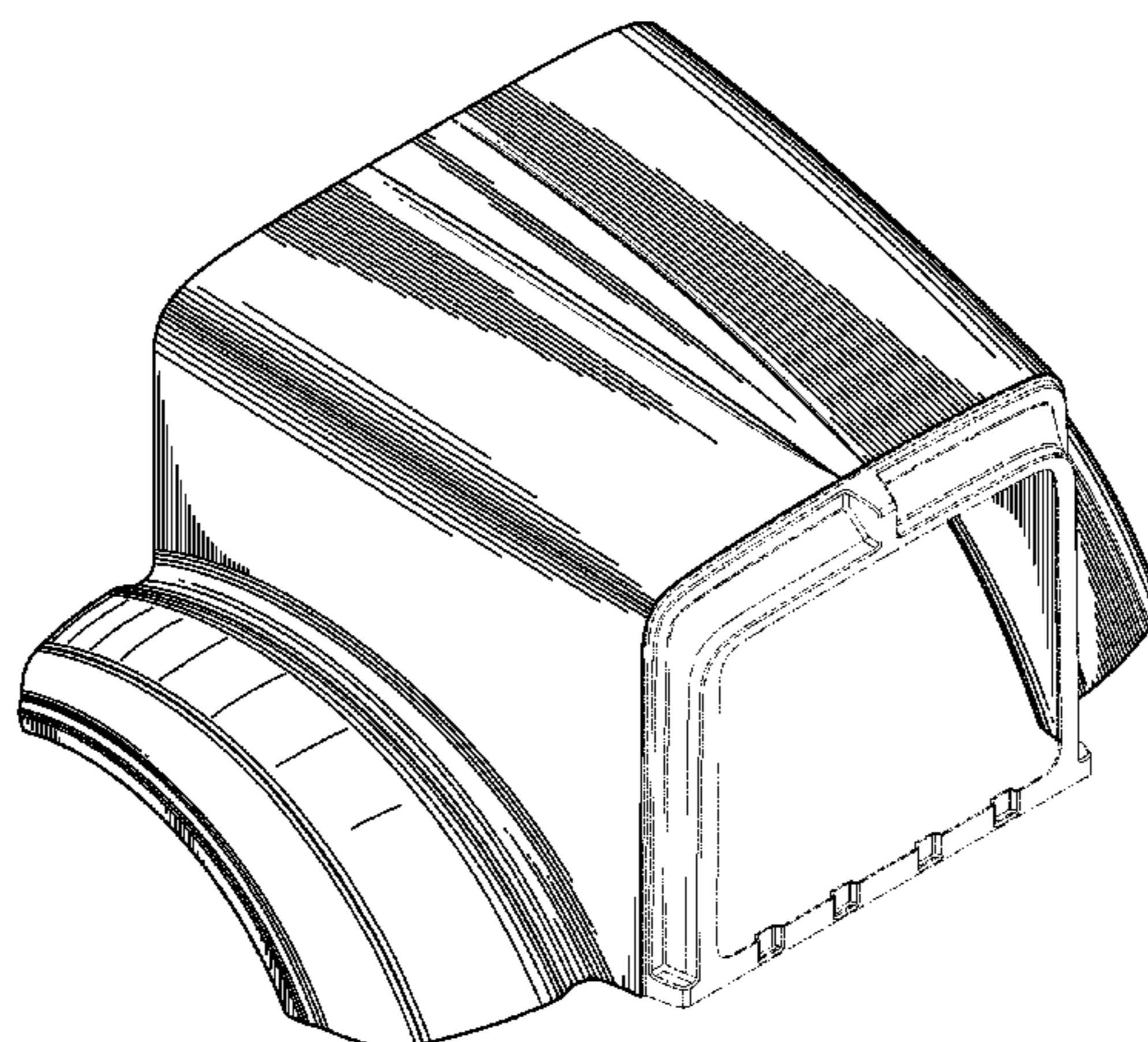

# US D563,852 S

Page 2

## U.S. PATENT DOCUMENTS

D422,251 S 4/2000 Bader  
D423,990 S 5/2000 Meryman  
D424,489 S 5/2000 Damon  
D424,993 S 5/2000 Farzam  
D425,450 S 5/2000 Barraclough  
D425,835 S 5/2000 Cook et al.  
D431,806 S 10/2000 Damon  
D433,980 S 11/2000 Conway  
D433,981 S 11/2000 Davis  
D434,347 S 11/2000 Damon  
D434,358 S 11/2000 Conway  
D435,816 S 1/2001 Delashaw  
D436,563 S 1/2001 Delashaw  
D436,894 S 1/2001 Barraclough  
D437,258 S 2/2001 Meryman  
D437,570 S 2/2001 Meryman  
D443,853 S 6/2001 Barraclough  
D446,175 S 8/2001 Hoyle, Jr.  
D450,277 S 11/2001 Onopa  
D452,464 S 12/2001 Beigel  
D455,381 S 4/2002 Maher  
D460,023 S 7/2002 Beigel  
D465,749 S 11/2002 Beigel  
D466,450 S 12/2002 Maher  
D475,657 S 6/2003 Wong  
D478,300 S 8/2003 Chiang  
D482,993 S 12/2003 Conway  
D484,077 S 12/2003 Conway  
D486,102 S 2/2004 Perfetti  
D488,112 S 4/2004 Satou  
D490,749 S 6/2004 Satou  
D492,801 S 7/2004 Metros  
D492,921 S 7/2004 Perfetti  
D494,900 S 8/2004 Satou

D497,581 S 10/2004 Conway  
D502,897 S 3/2005 Delashaw  
D502,901 S 3/2005 Delashaw  
D502,904 S 3/2005 Delashaw  
D504,642 S 5/2005 Perfetti  
D511,727 S 11/2005 Shaw  
D512,666 S 12/2005 Chiang  
D514,483 S 2/2006 Chiang  
D515,474 S 2/2006 Wu  
D518,761 S 4/2006 Chiang  
D522,426 S 6/2006 Beigel  
D522,945 S 6/2006 Beigel  
D540,725 S \* 4/2007 Gunter et al. .... D12/173  
D545,251 S \* 6/2007 Angelo et al. .... D12/173  
D545,735 S \* 7/2007 Angelo et al. .... D12/173

## OTHER PUBLICATIONS

Kenworth Truck Company W900 brochure, Kirkland, Wash., 2002.  
Kenworth Truck Company W900 brochure, Kirkland, Wash., 1996.  
Kenworth Truck Company T2000 brochure, Kirkland, Wash., 2005.  
Kenworth Truck Company T2000 brochure, Kirkland, Wash., 2002.  
Kenworth Truck Company T800 brochure, Kirkland, Wash., 2005.  
Kenworth Truck Company T800 brochure, Kirkland, Wash., 2003.  
Kenworth Truck Company T800 brochure, Kirkland, Wash., 2002.  
Kenworth Truck Company T600 brochure, Kirkland, Wash., 2005.  
Kenworth Truck Company T600 brochure, Kirkland, Wash., 2002.  
Kenworth Truck Company T600 brochure, Kirkland, Wash., 1996.  
Kenworth Truck Company T300 brochure, Kirkland, Wash., 2005.  
Kenworth Truck Company T300 brochure, Kirkland, Wash., 2001.  
Peterbilt Motors Company, Models brochure, Denton, Texas, 1997.  
Peterbilt Motors Company, 357 brochure, Denton, Texas, 1999.  
Peterbilt Motors Company, Construction Trucks brochure, Denton, Texas, 2003.  
Peterbilt Motors Company, Models brochure, Denton, Texas, 2005.

\* cited by examiner

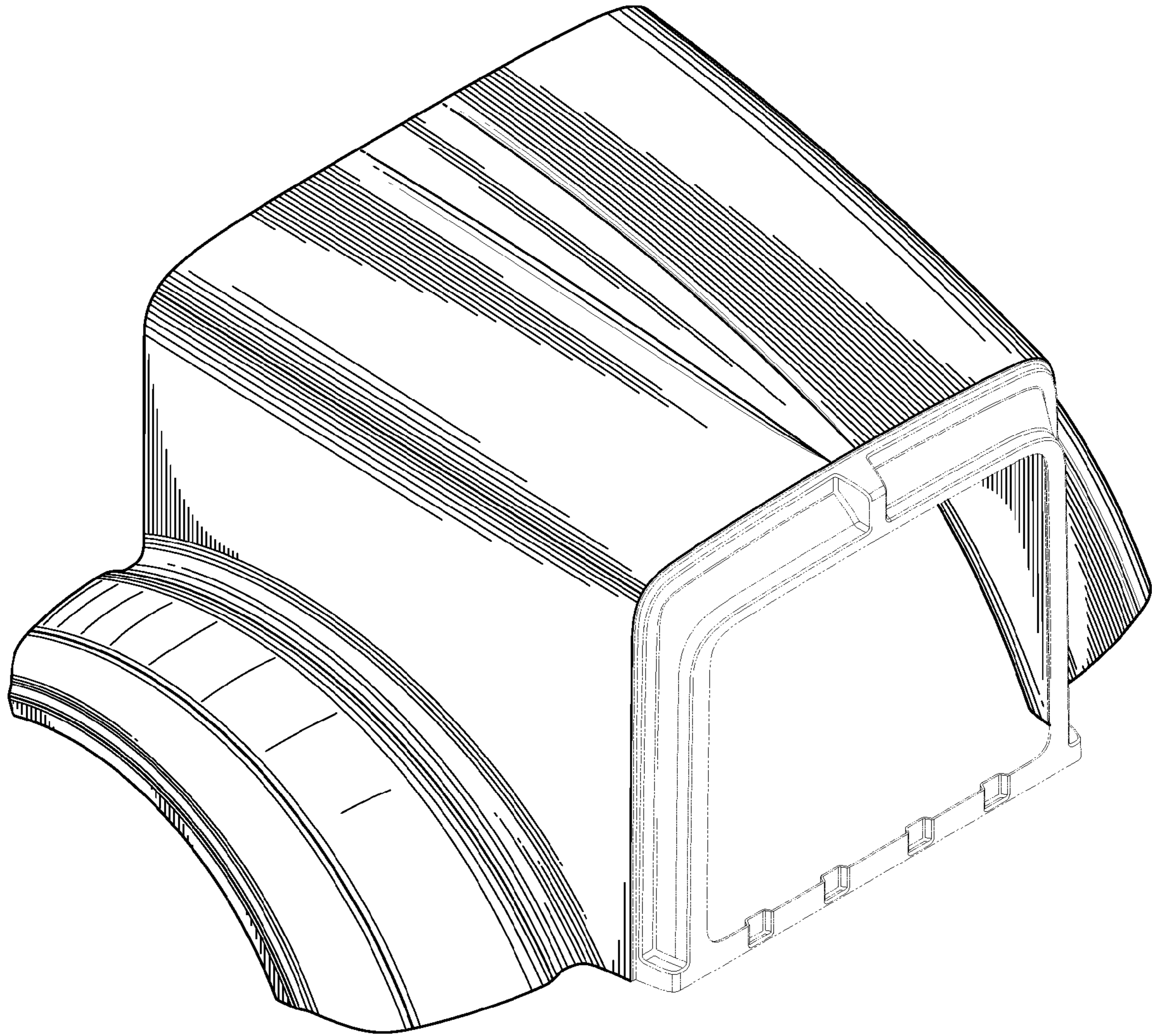

*Fig. 1.*

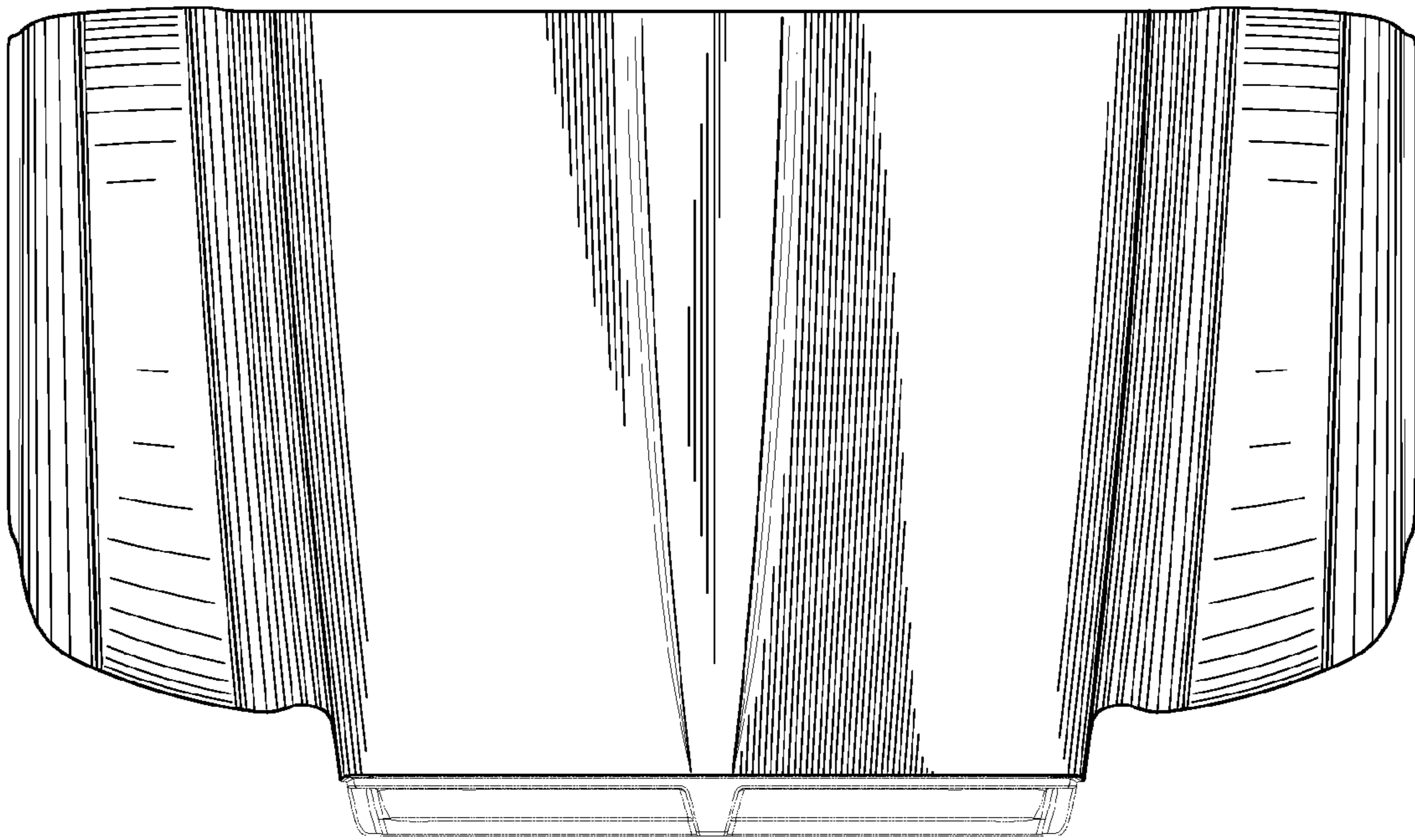

*Fig. 2.*

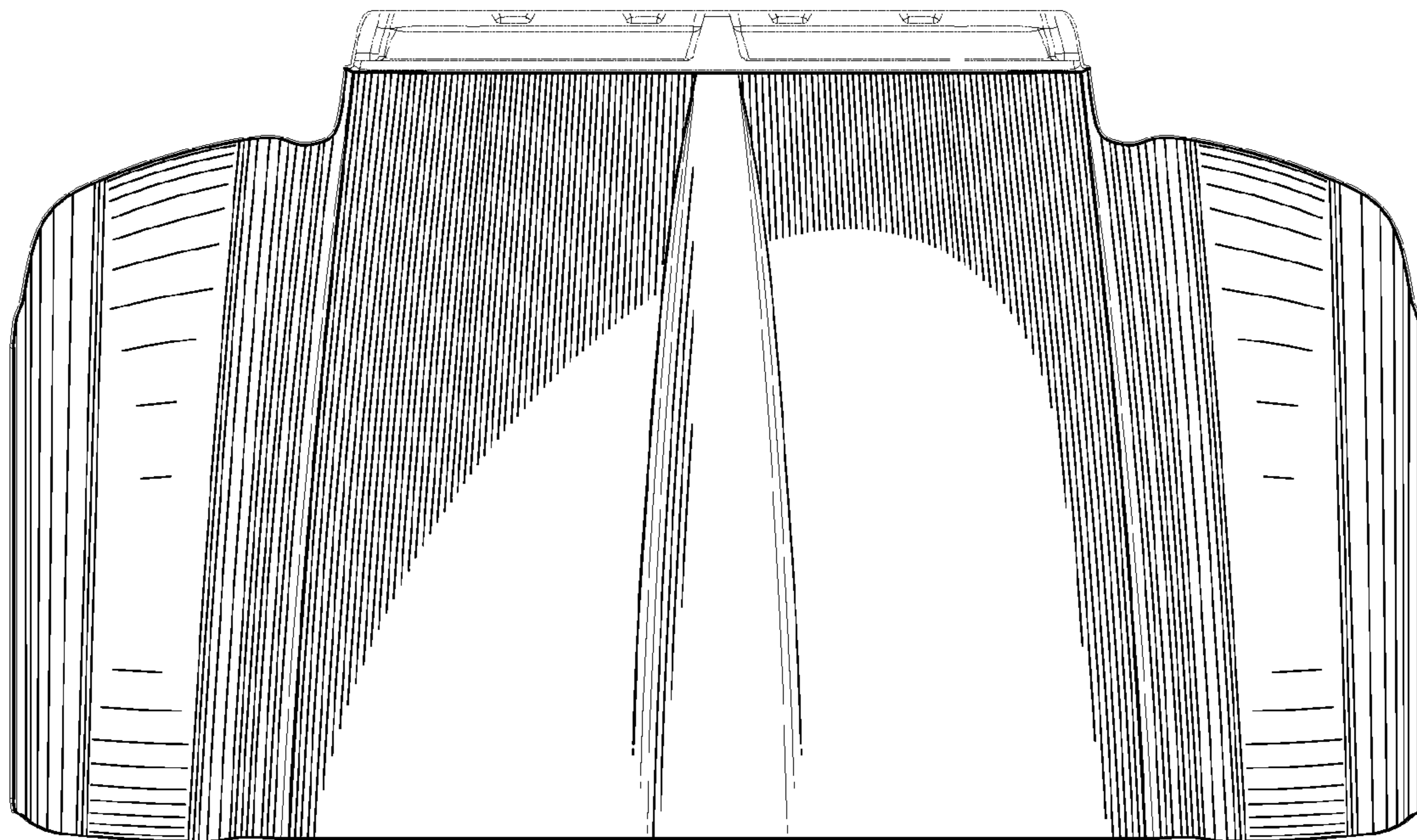

*Fig.3.*

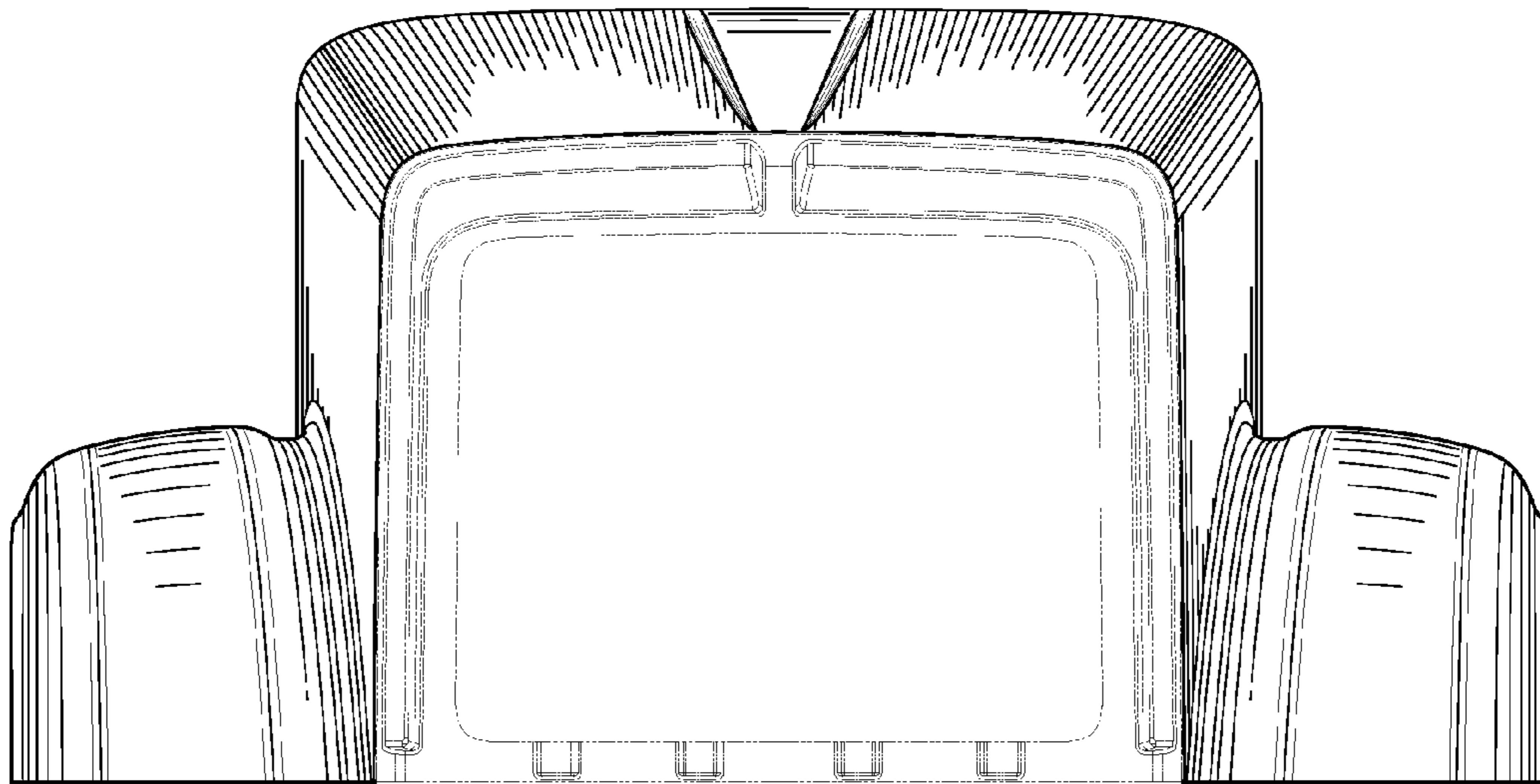

*Fig. 4.*

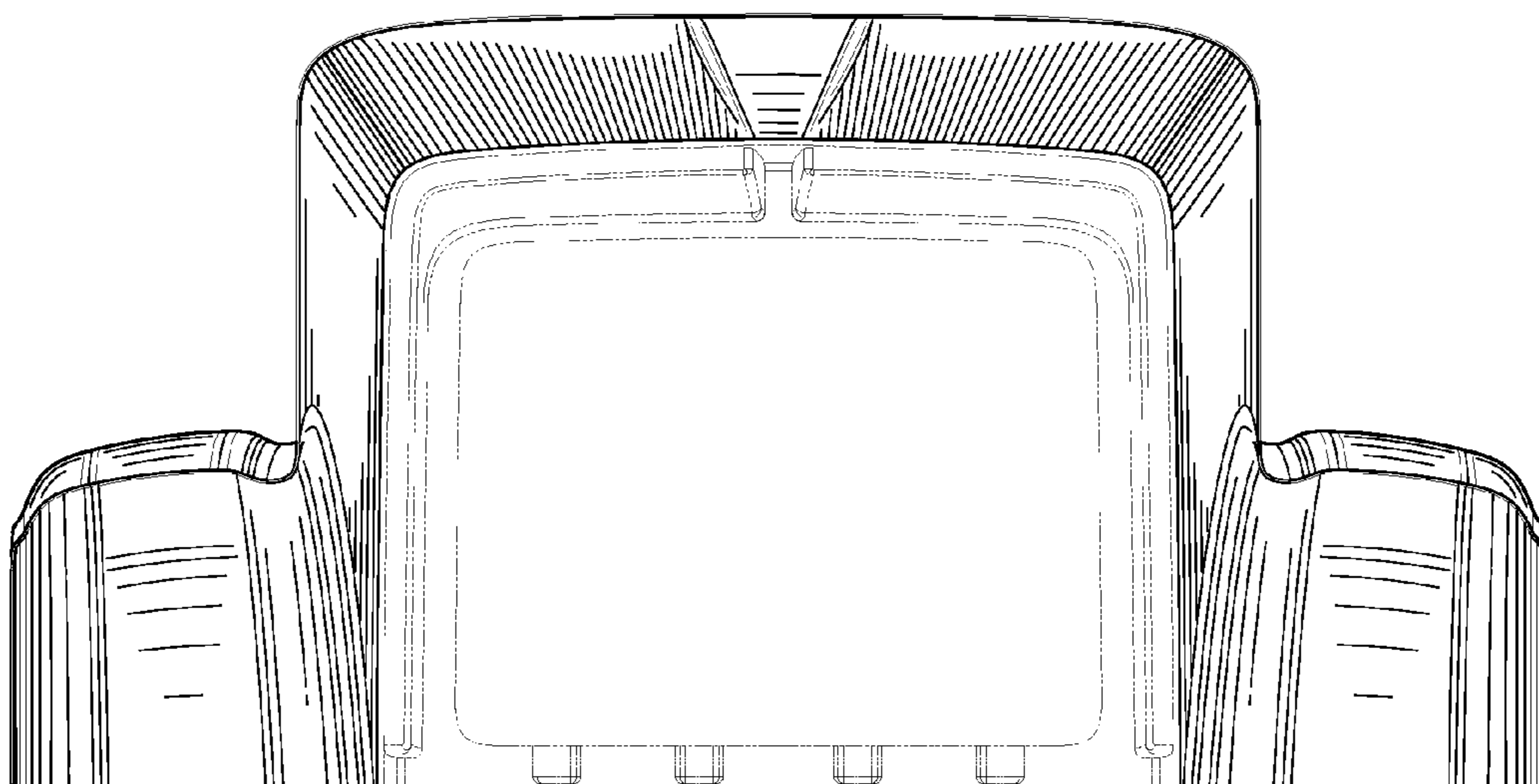

*Fig. 5.*

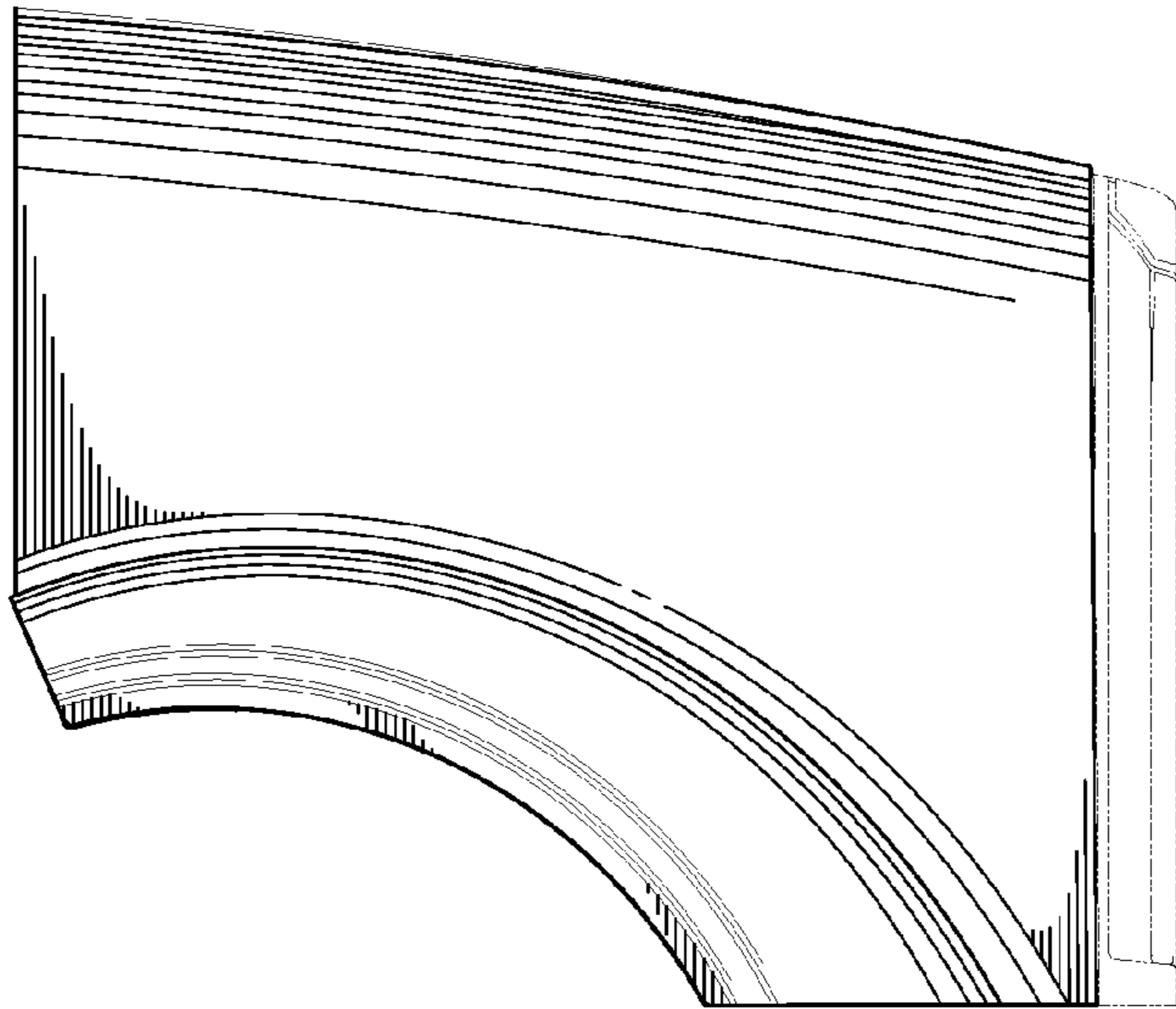

*Fig. 6.*

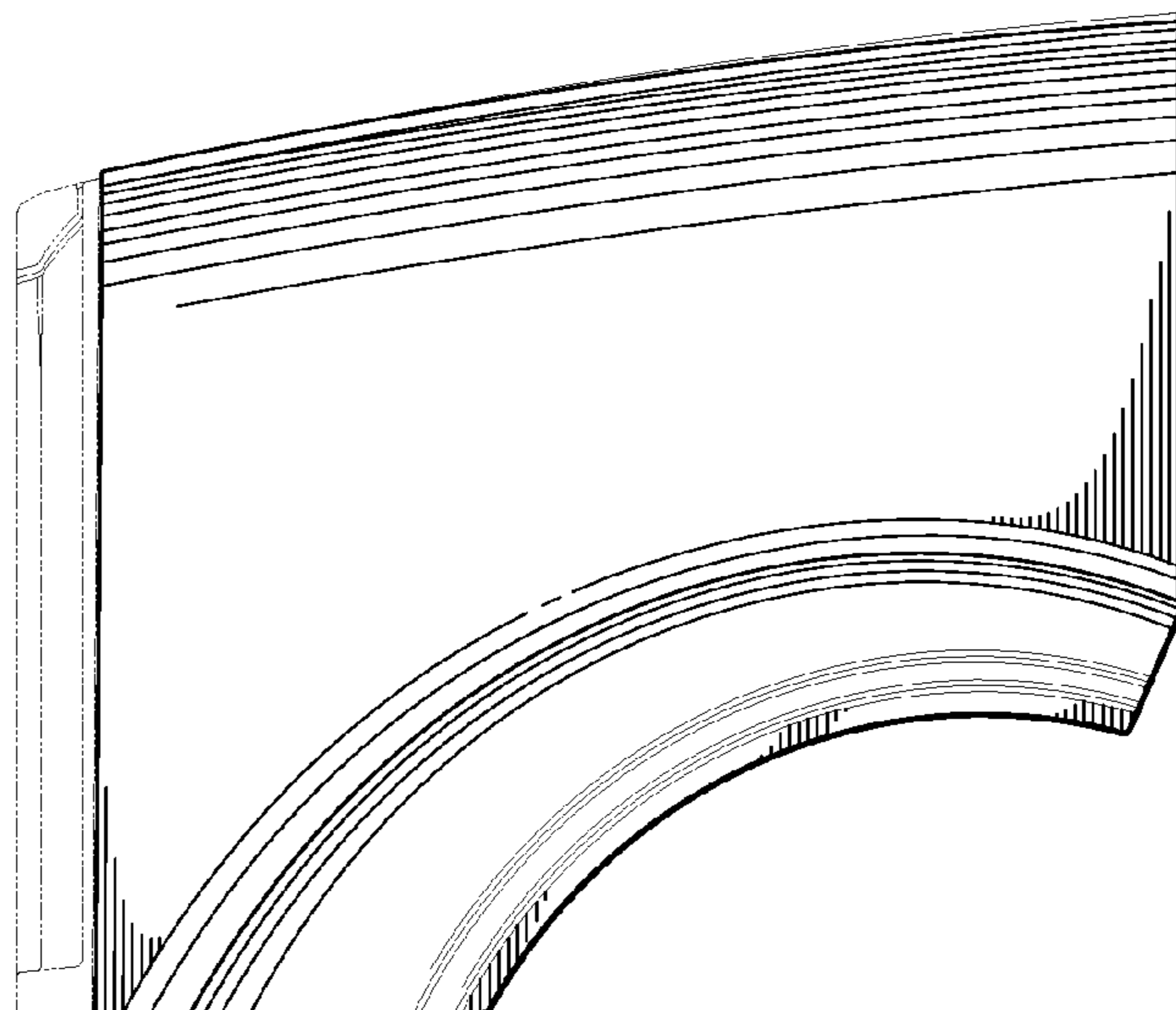

*Fig. 7.*

UNITED STATES PATENT AND TRADEMARK OFFICE  
**CERTIFICATE OF CORRECTION**

PATENT NO. : Des. 563,852 S  
APPLICATION NO. : 29/278176  
DATED : March 11, 2008  
INVENTOR(S) : Rosen et al.

Page 1 of 1

It is certified that error appears in the above-identified patent and that said Letters Patent is hereby corrected as shown below:

On the title page: Item [75] Inventors: insert -- Scott M. Conway, Flower Mound, Texas --.

Signed and Sealed this

Twenty-second Day of July, 2008

A handwritten signature in black ink that reads "Jon W. Dudas". The signature is written in a cursive style with a large, looped initial "J".

JON W. DUDAS

*Director of the United States Patent and Trademark Office*