



US00D563749S

(12) **United States Design Patent**
Okuda et al.

(10) **Patent No.:** **US D563,749 S**
(45) **Date of Patent:** **** Mar. 11, 2008**

(54) **PORTABLE ELECTRIC CHISEL**
(75) Inventors: **Shinsuke Okuda**, Anjo (JP); **Takayoshi Iio**, Anjo (JP)
(73) Assignee: **Makita Corporation**, Anjo (JP)
(**) Term: **14 Years**
(21) Appl. No.: **29/273,419**
(22) Filed: **Mar. 6, 2007**

D524,626 S * 7/2006 Stirm D8/69
D525,849 S 8/2006 Hayakawa et al.
D526,179 S * 8/2006 Hayakawa et al. D8/69
D528,393 S * 9/2006 Stirm D8/69
D540,642 S * 4/2007 Stirm D8/69
2004/0112615 A1 * 6/2004 Mayr et al. 173/217
2004/0211575 A1 * 10/2004 Soika et al. 173/217
2005/0087353 A1 * 4/2005 Oki et al. 173/170
2006/0060365 A1 * 3/2006 Kunz 173/170
2006/0144603 A1 * 7/2006 Arich et al. 173/114

(30) **Foreign Application Priority Data**
Oct. 27, 2006 (JP) 2006-029302

(51) **LOC (8) Cl.** **08-05**
(52) **U.S. Cl.** **D8/69**
(58) **Field of Classification Search** D8/14.1,
D8/61-70; 81/57.11, 429, 454-456, 469,
81/489; 173/13, 104, 114, 168-171, 178,
173/201, 211, 213, 217; 408/20, 124, 125,
408/234, 241 R; 451/358; 310/50; 227/8,
227/113, 114, 120, 130, 136, 142
See application file for complete search history.

(56) **References Cited**
U.S. PATENT DOCUMENTS
4,998,588 A * 3/1991 Manschitz 173/104
D380,132 S * 6/1997 Matsunaga et al. D8/69
5,653,296 A * 8/1997 Fujiyama 173/170
D395,586 S * 6/1998 Arakawa et al. D8/69
D466,780 S * 12/2002 Stirm D8/69
6,776,245 B2 * 8/2004 Kristen et al. 173/171
6,938,705 B2 * 9/2005 Kikuchi 173/201

FOREIGN PATENT DOCUMENTS

JP S 1238857 5/2005

* cited by examiner

Primary Examiner—T. Chase Nelson
(74) *Attorney, Agent, or Firm*—Oliff & Berridge, PLC

(57) **CLAIM**

The ornamental design for a portable electric chisel, as shown and described.

DESCRIPTION

FIG. 1 is a perspective view of a portable electric chisel;
FIG. 2 is a right side elevation view thereof;
FIG. 3 is a left side elevation view thereof;
FIG. 4 is a front elevation view thereof;
FIG. 5 is a rear elevation view thereof;
FIG. 6 is a top plan view thereof; and,
FIG. 7 is a bottom plan view thereof.

1 Claim, 5 Drawing Sheets

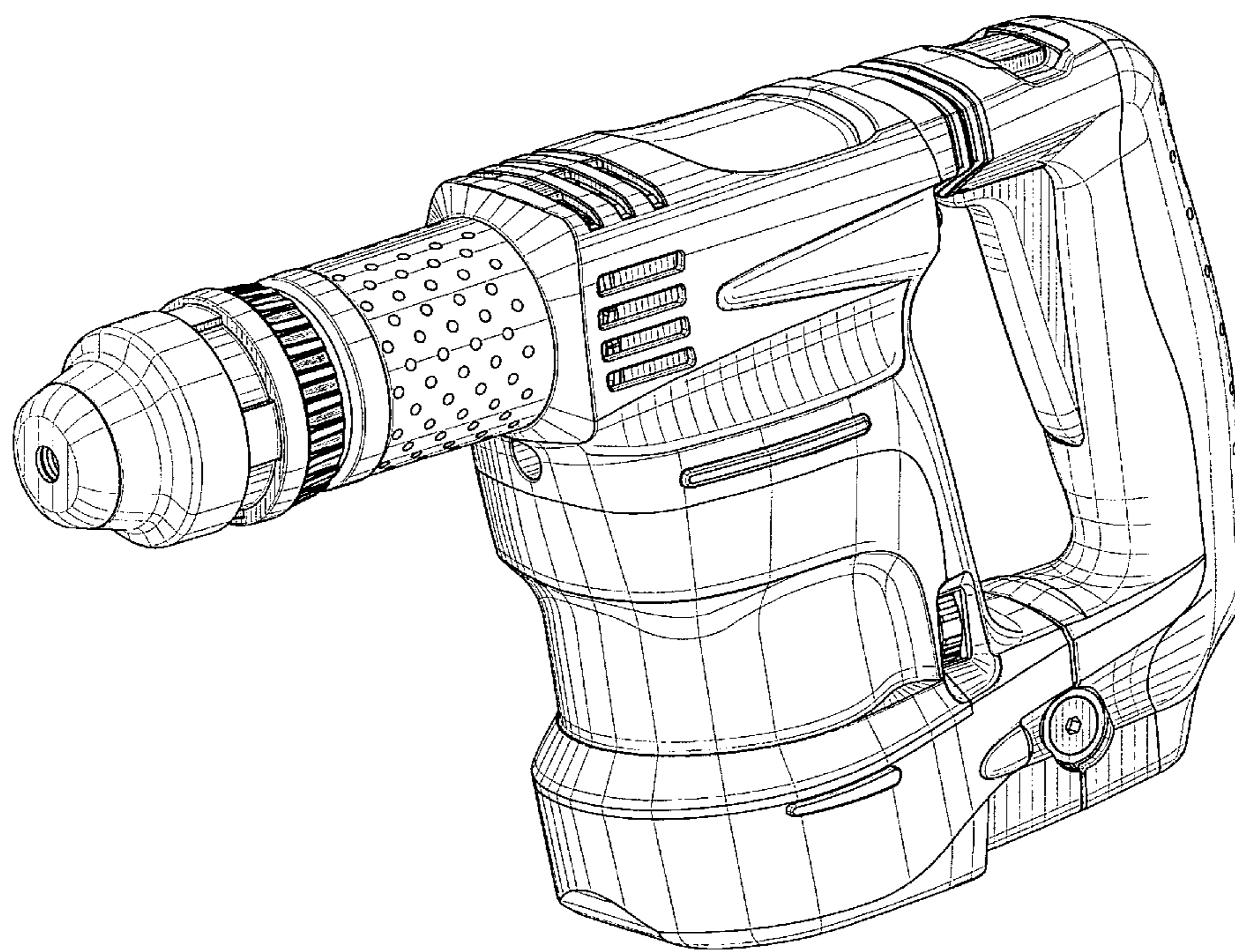

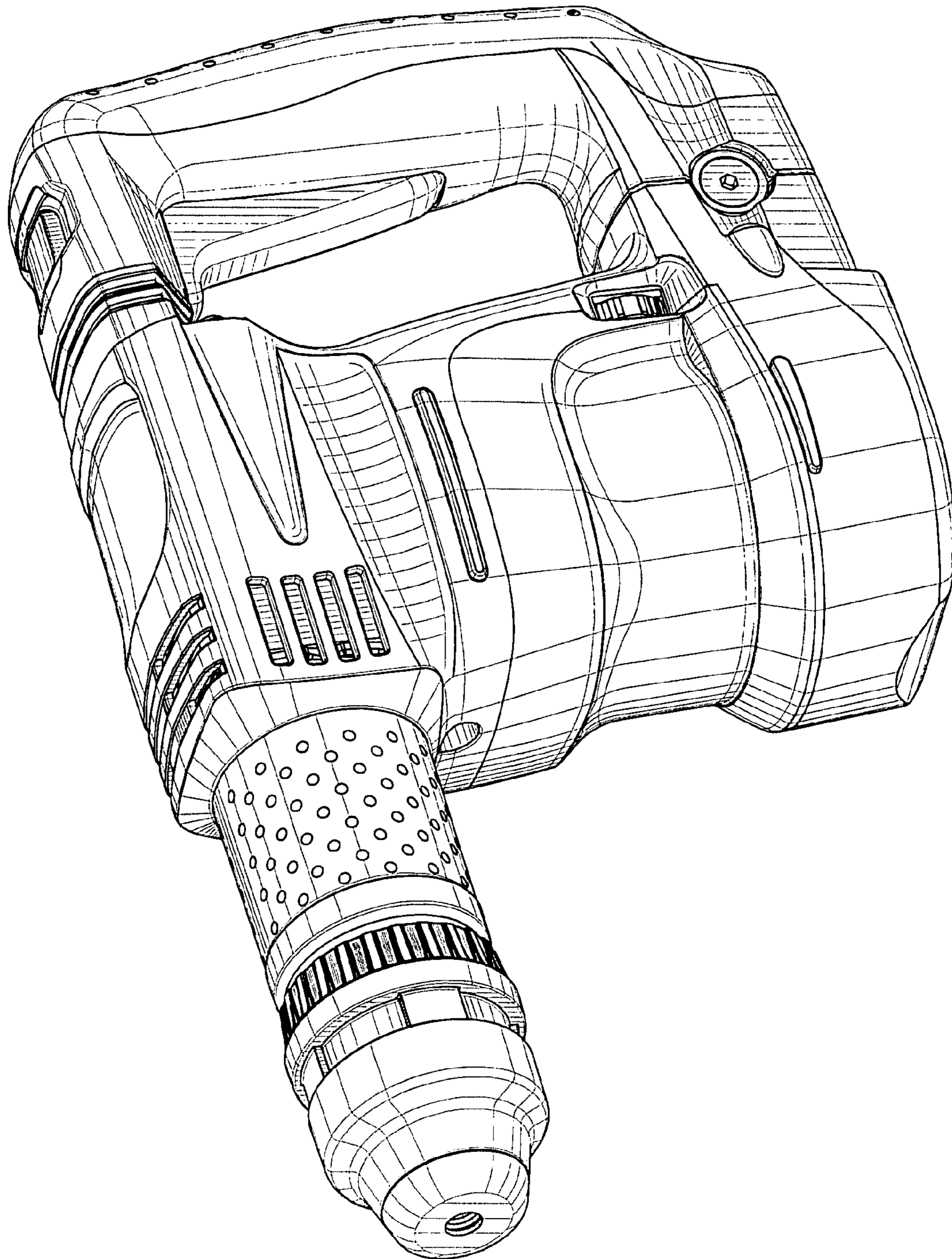

FIG. 1

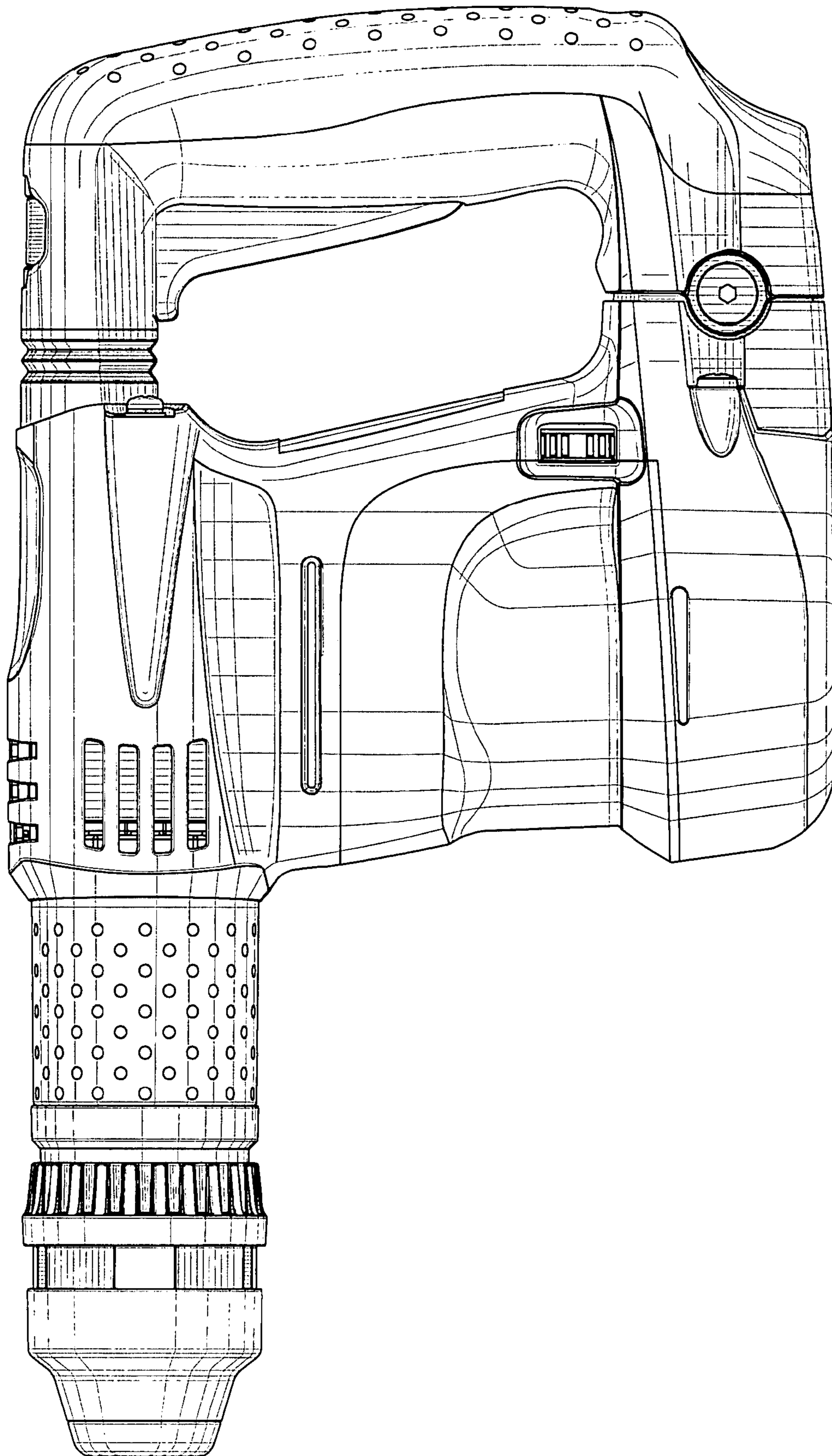

FIG. 2

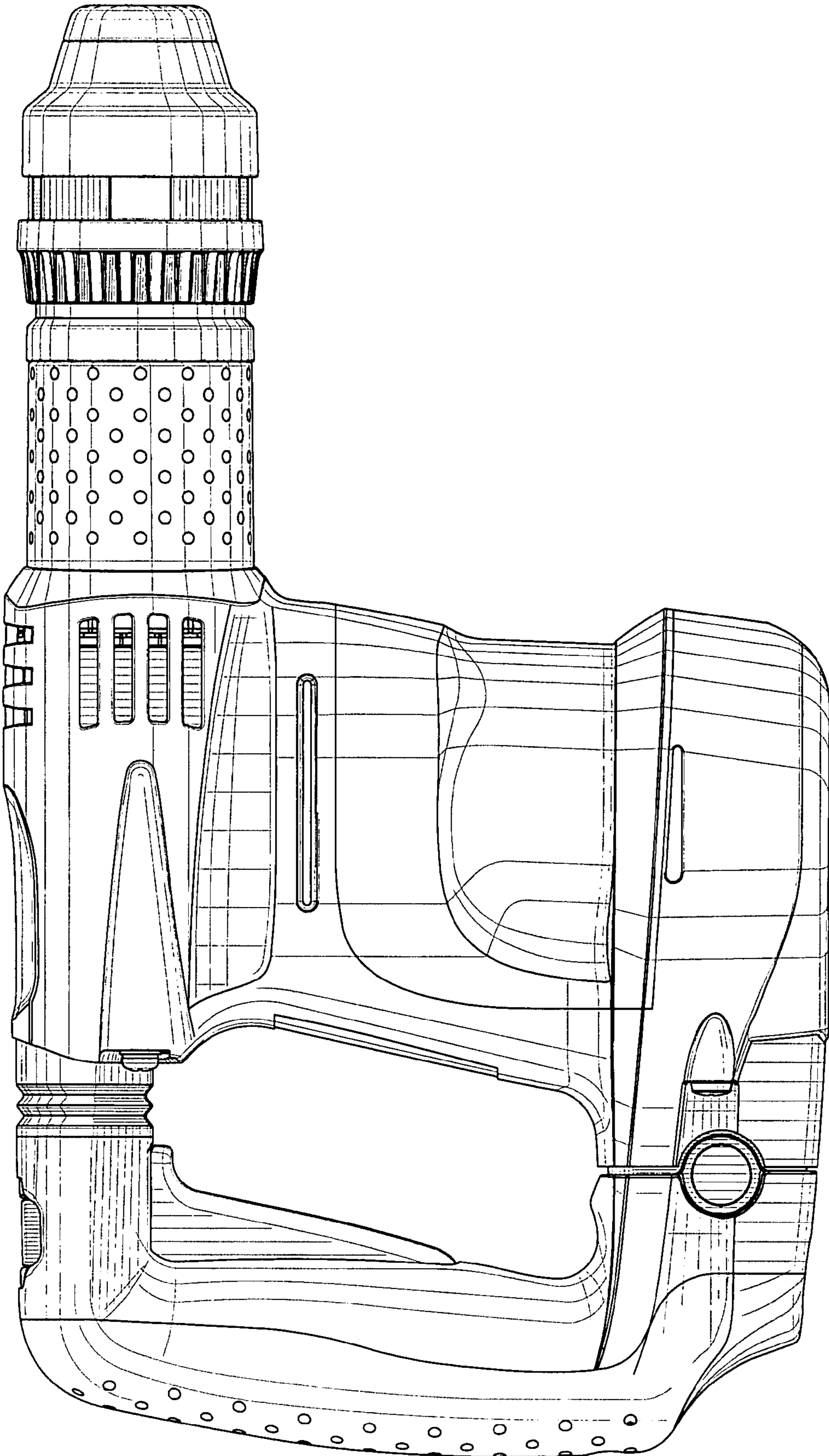

FIG. 3

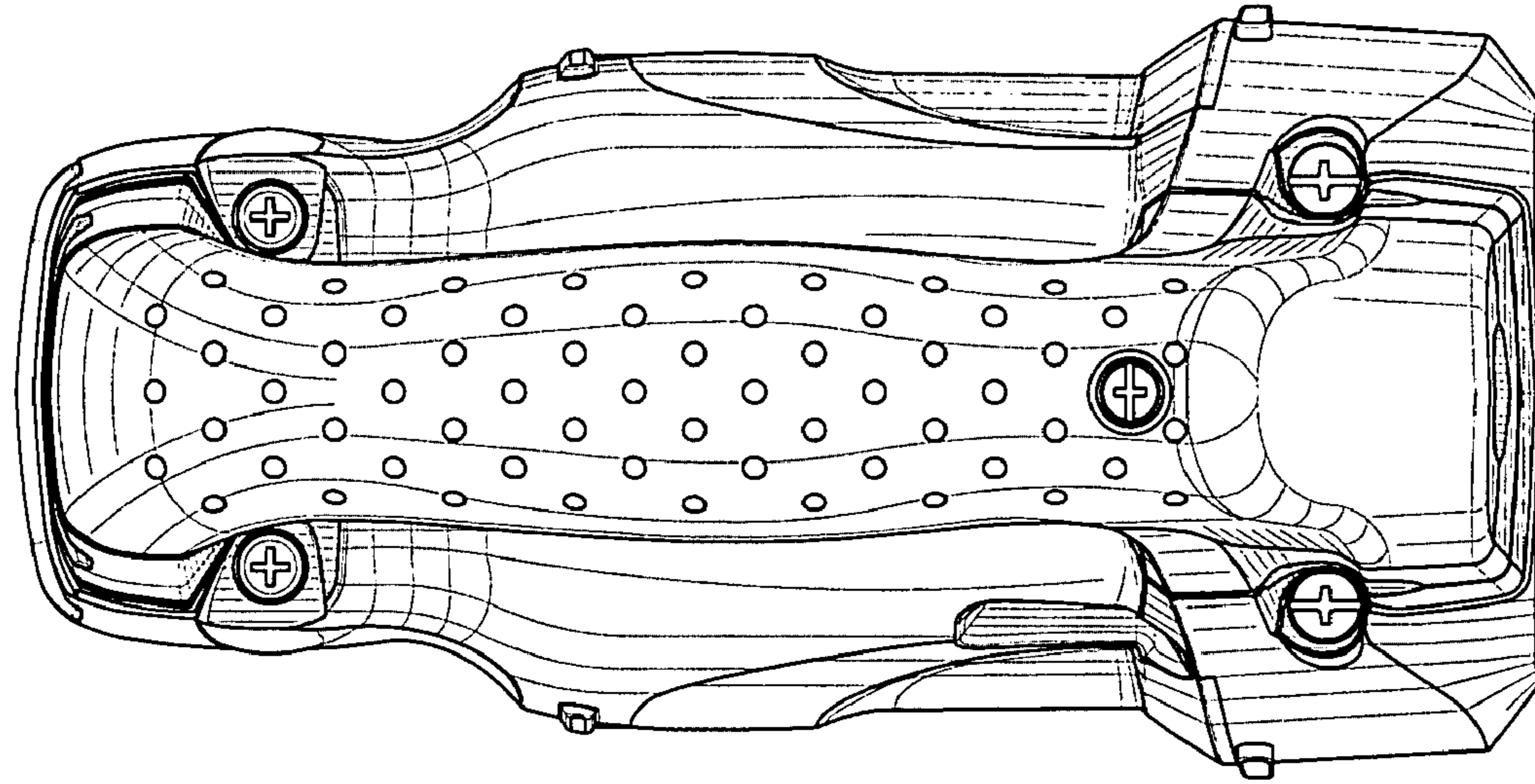

FIG. 4

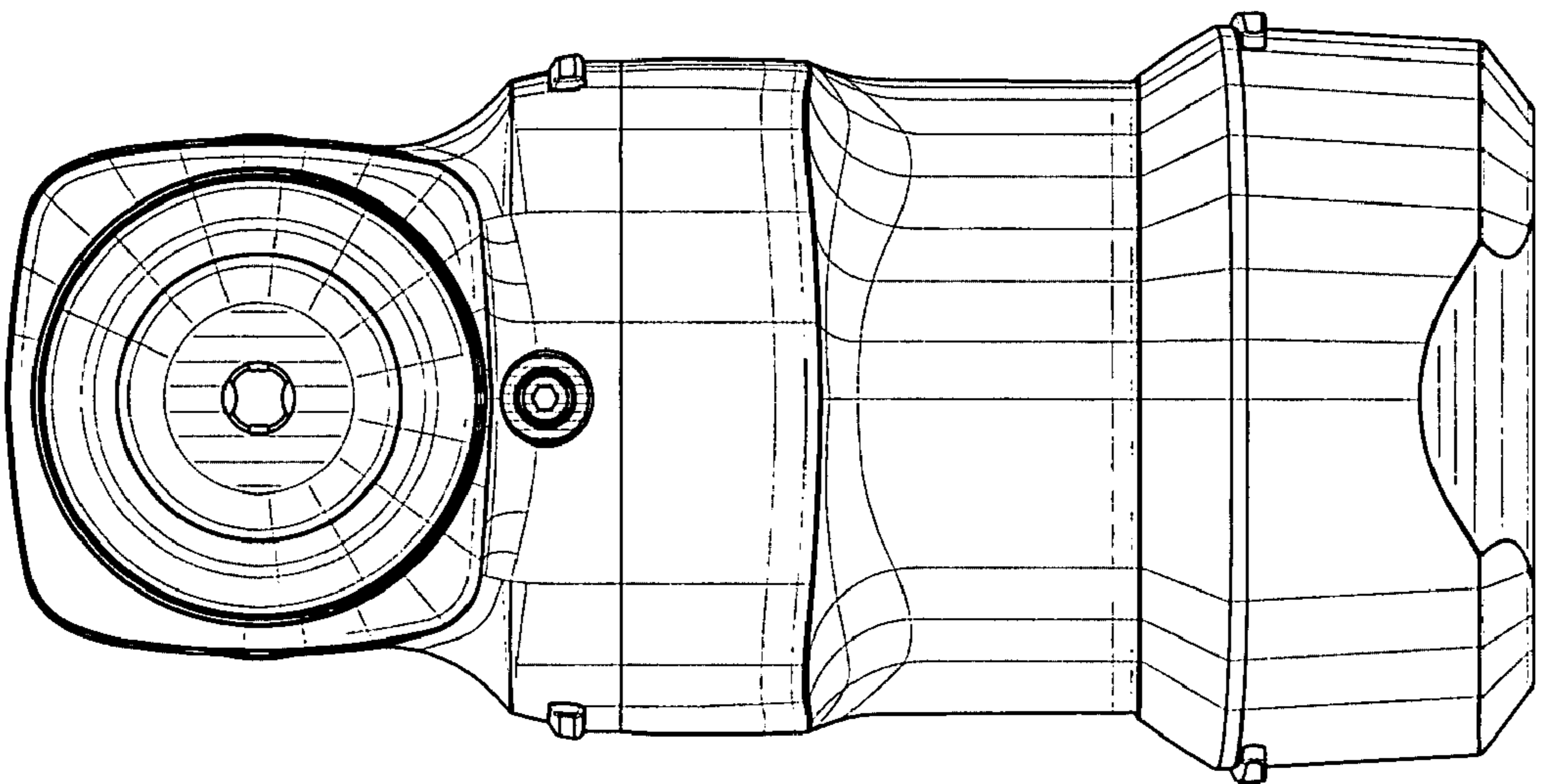

FIG. 5

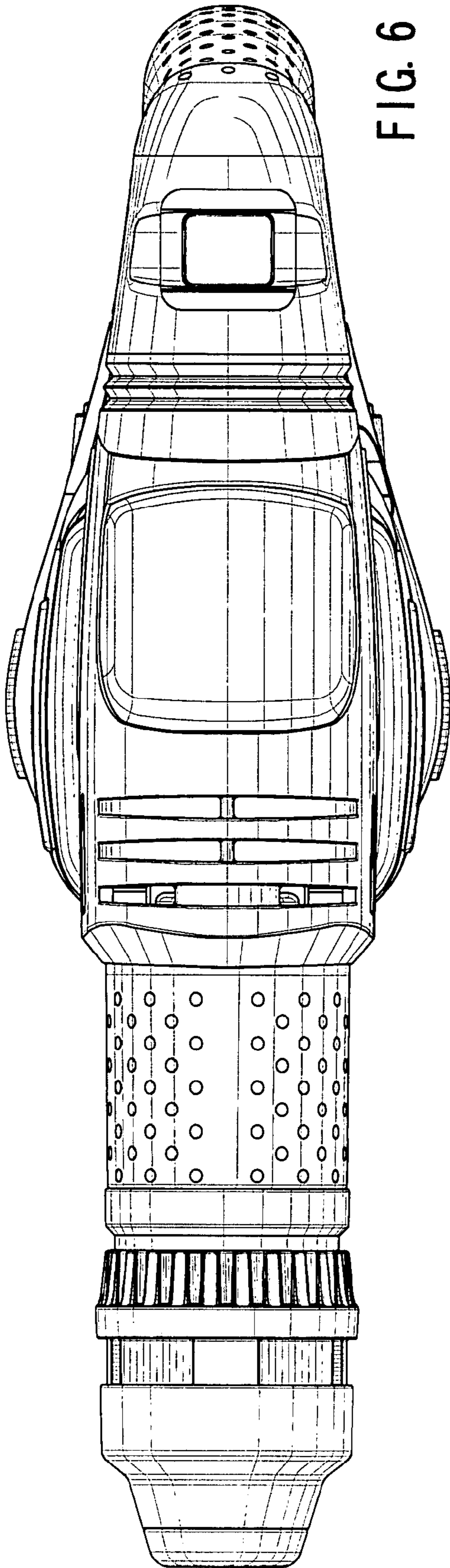

FIG. 6

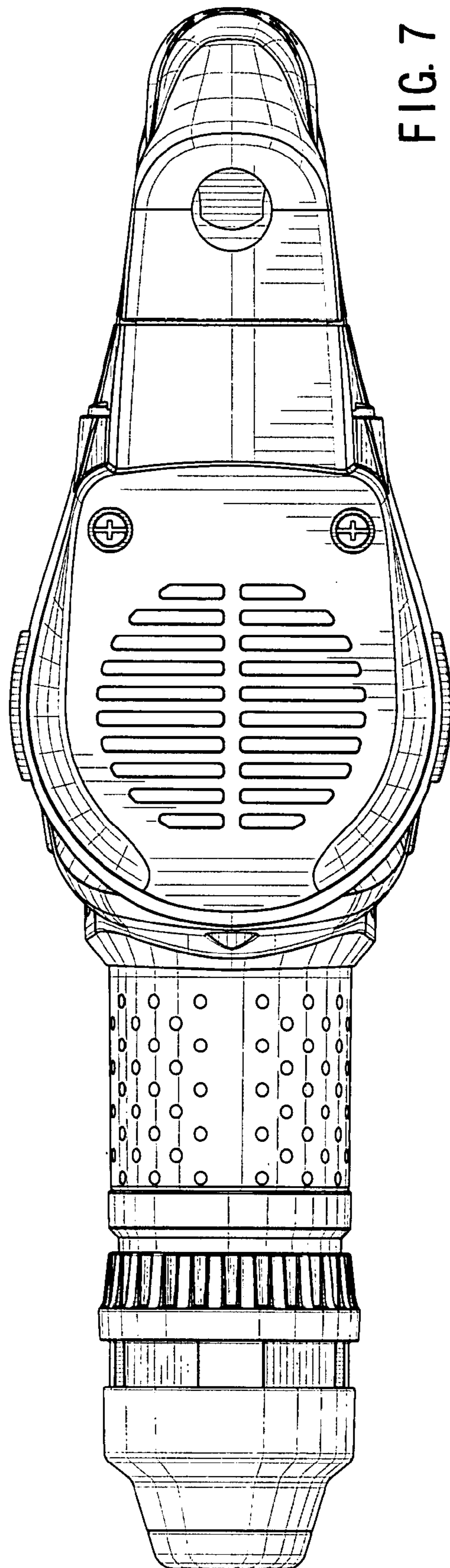

FIG. 7