



US00D563294S

(12) **United States Design Patent**
Shimizu

(10) **Patent No.:** **US D563,294 S**

(45) **Date of Patent:** **** Mar. 4, 2008**

(54) **STEERING WHEEL FOR AUTOMOBILES**

(75) Inventor: **Yosuke Shimizu**, Wako (JP)

(73) Assignee: **Honda Motor Co., Ltd.**, Tokyo (JP)

(**) Term: **14 Years**

(21) Appl. No.: **29/276,355**

(22) Filed: **Jan. 23, 2007**

(30) **Foreign Application Priority Data**

Jul. 24, 2006 (JP) 2006-019376

(51) **LOC (8) Cl.** **12-16**

(52) **U.S. Cl.** **D12/176**

(58) **Field of Classification Search** D12/175-177;
74/552, 558, 558.5

See application file for complete search history.

(56) **References Cited**

U.S. PATENT DOCUMENTS

D502,903 S *	3/2005	Hebert et al.	D12/176
D513,721 S *	1/2006	Pfeiffer	D12/176
D514,485 S *	2/2006	Juraschek et al.	D12/176
D515,479 S *	2/2006	Yamazaki et al.	D12/176
D521,426 S *	5/2006	Hoffmann	D12/176
D535,924 S *	1/2007	Kitajima	D12/176

* cited by examiner

Primary Examiner—Melody N. Brown

(74) *Attorney, Agent, or Firm*—Westerman, Hattori, Daniels & Adrian, LLP.

(57) **CLAIM**

The ornamental design for a steering wheel for automobiles, as shown and described.

DESCRIPTION

FIG. 1 is a front view of the steering wheel for automobiles showing my new design;

FIG. 2 is a rear view of the steering wheel for automobiles;

FIG. 3 is a top plan view of the steering wheel for automobiles;

FIG. 4 is a bottom view of the steering wheel for automobiles;

FIG. 5 is a right side view of the steering wheel for automobiles, the left side view being a mirror image thereof;

FIG. 6 is a perspective view of the steering wheel for automobiles as seen from the right front side; and,

FIG. 7 is a perspective view of the steering wheel for automobiles as seen from the left front side.

The broken lines are for illustrative purposes only and form no part of the claimed design.

1 Claim, 4 Drawing Sheets

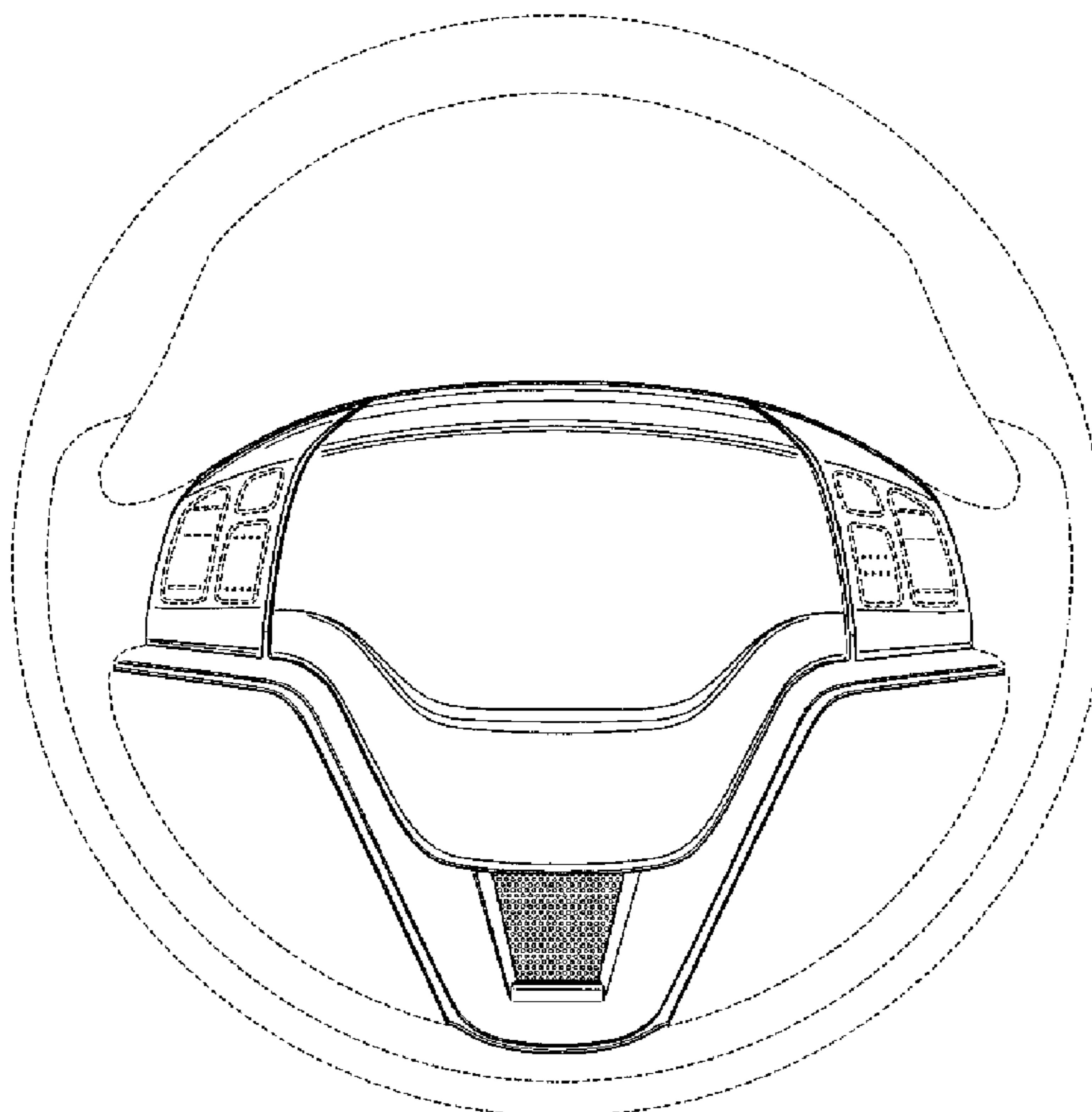

FIG.1

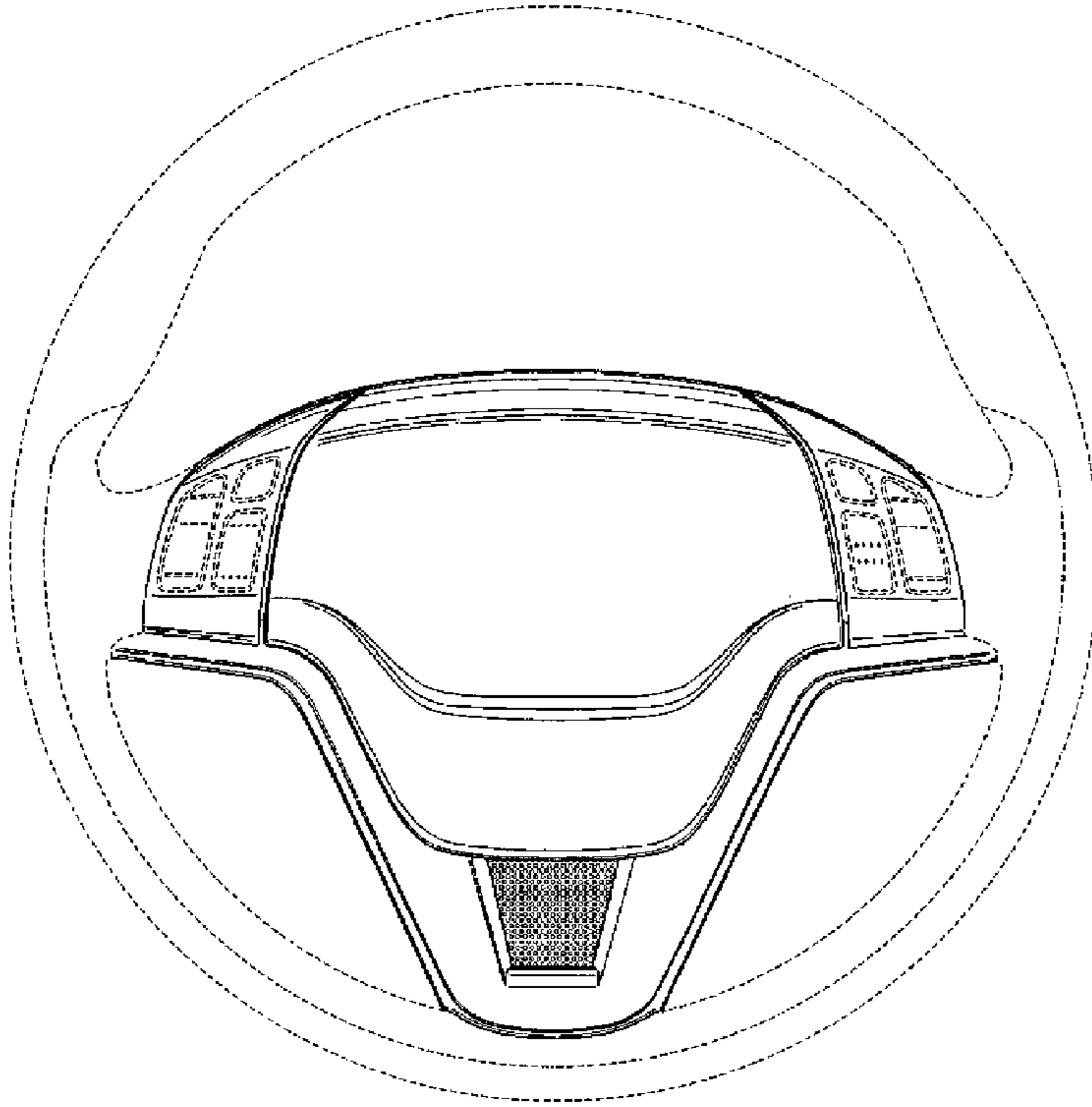

FIG.2

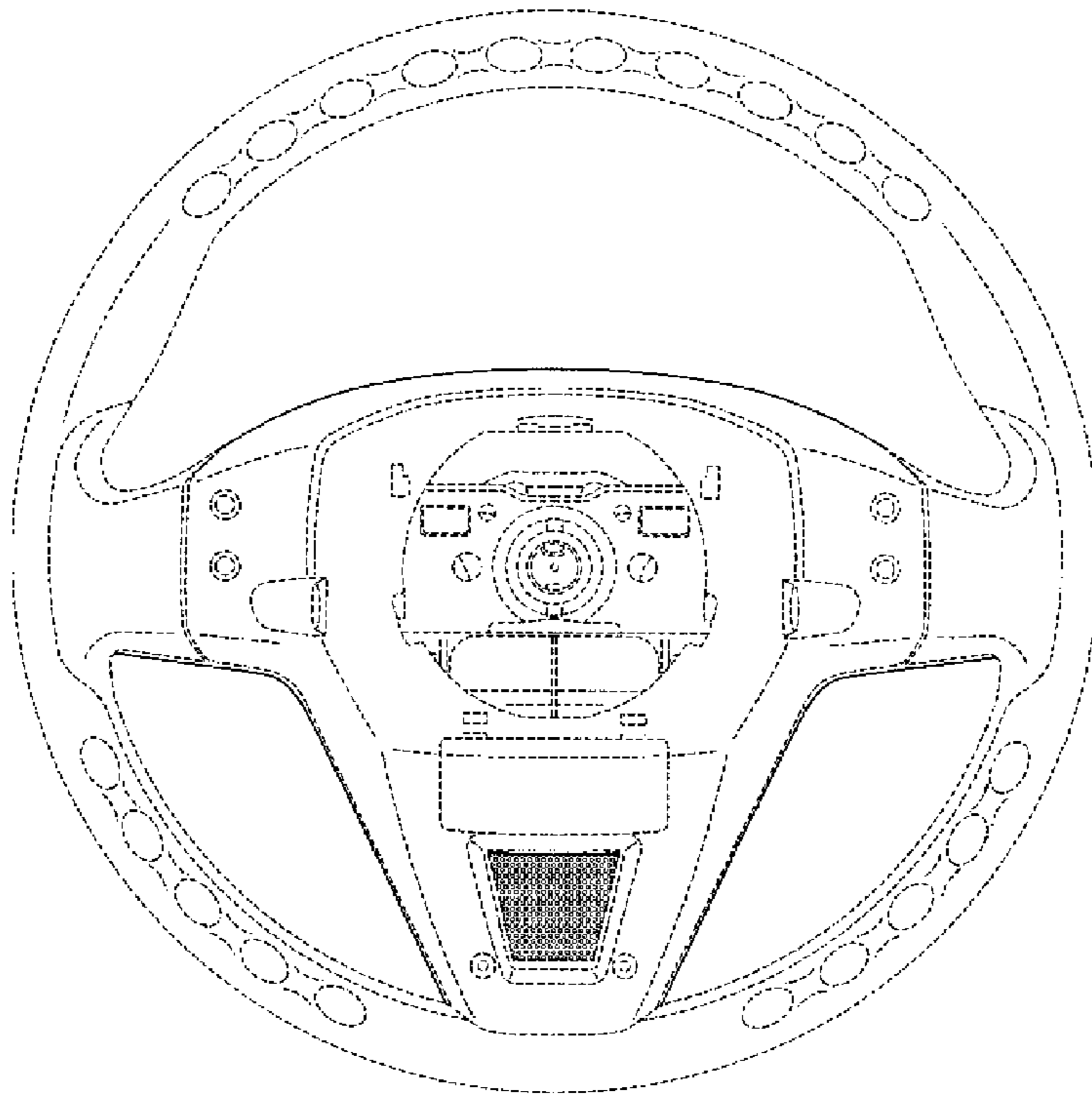

FIG.3

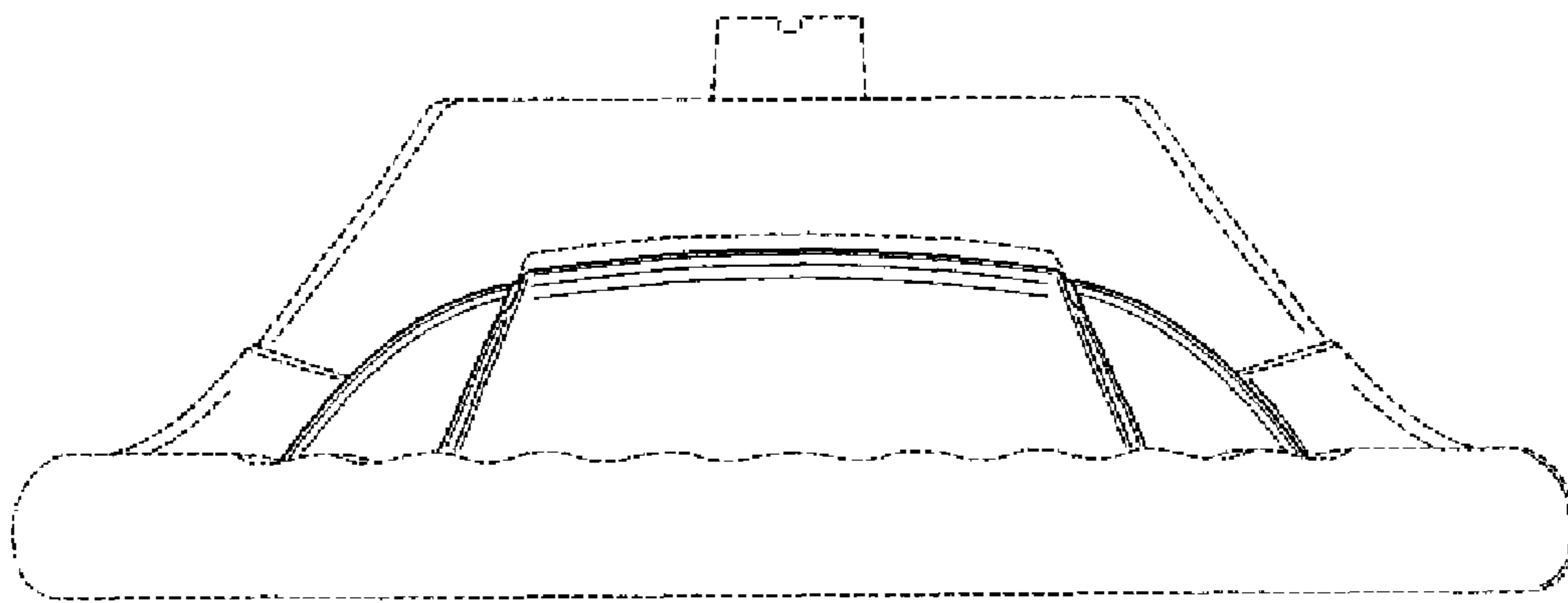

FIG.4

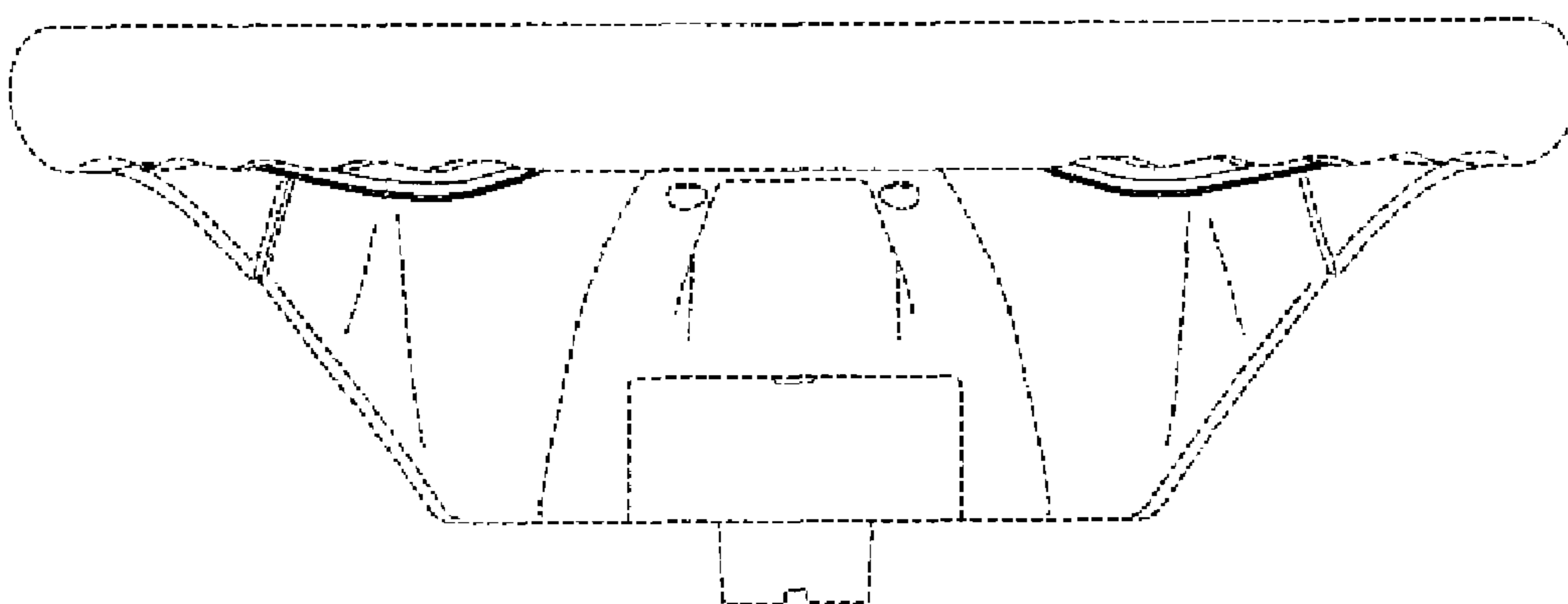

FIG.5

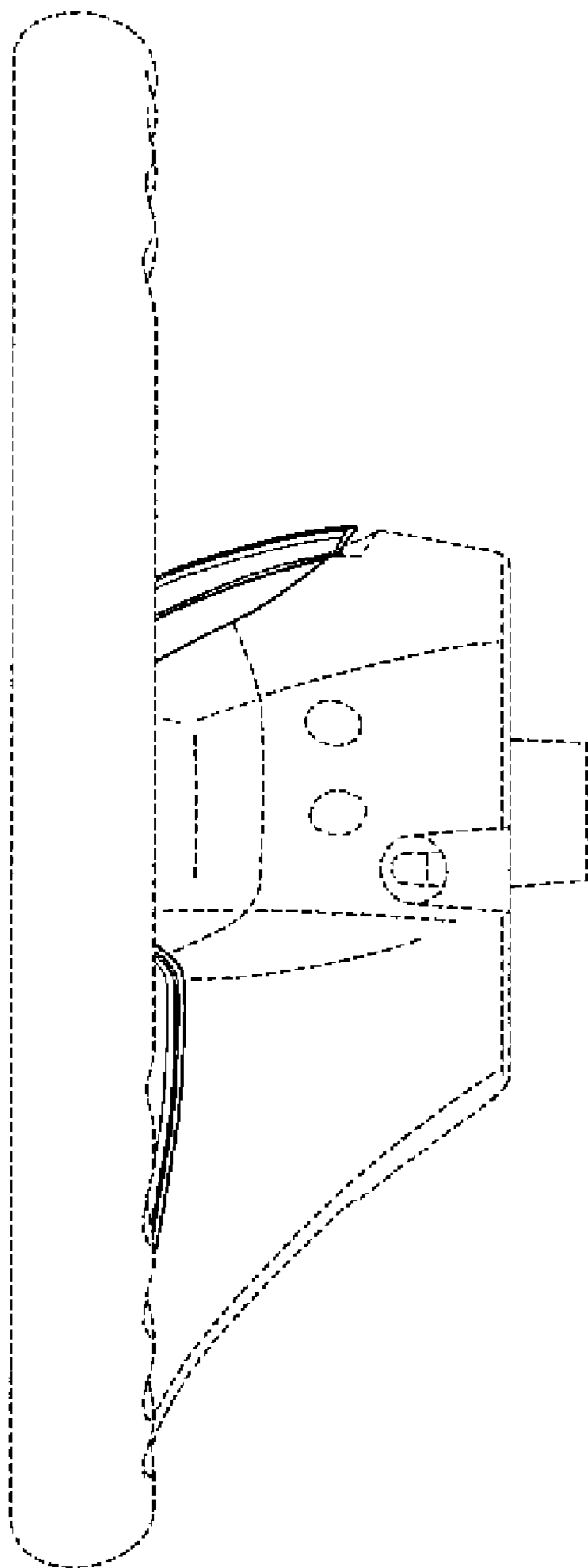

FIG.6

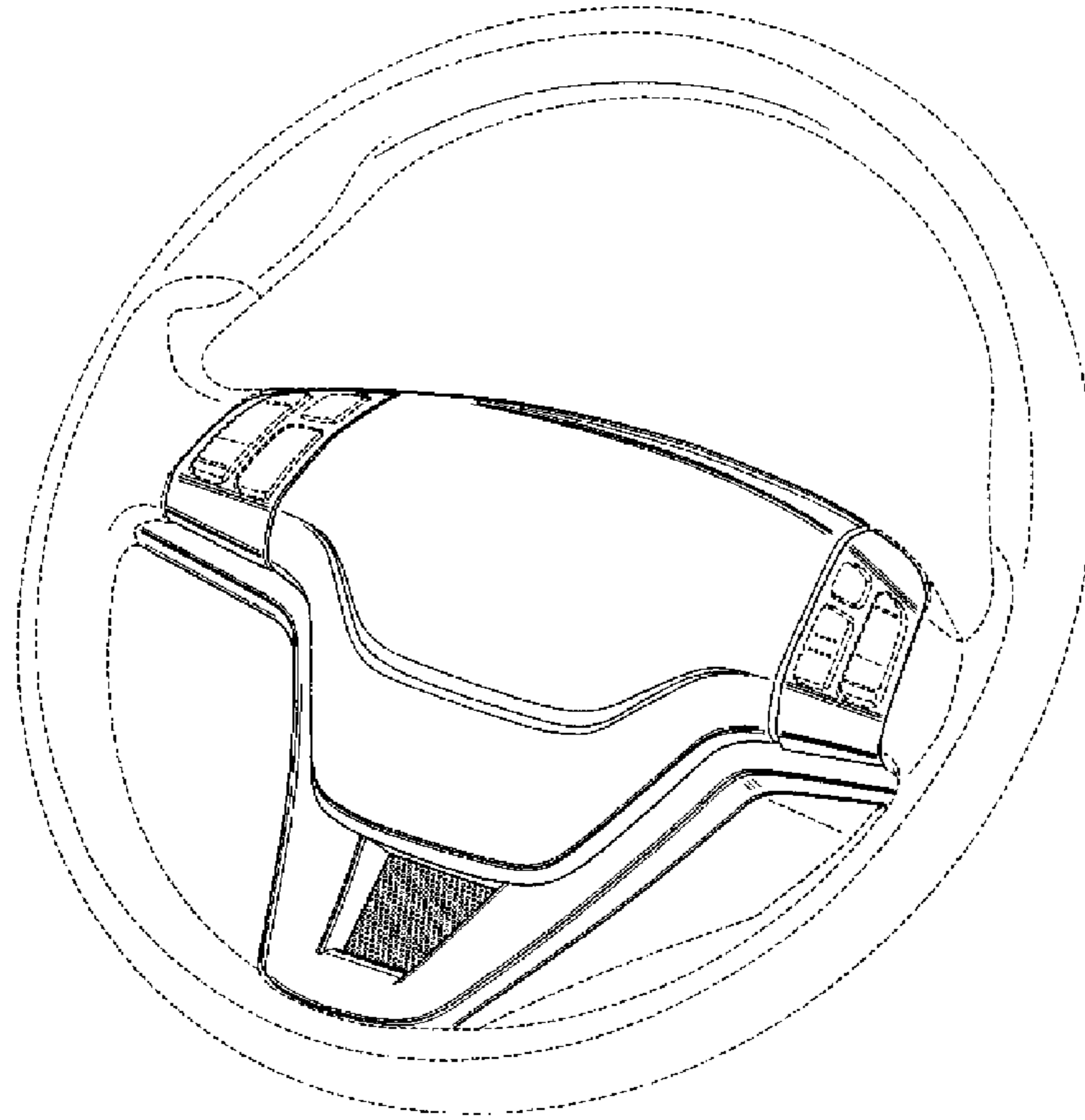

FIG.7

