



US00D563281S

(12) **United States Design Patent**  
**Simons et al.**

(10) **Patent No.:** **US D563,281 S**  
(45) **Date of Patent:** **\*\* \*Mar. 4, 2008**

(54) **TRUCK BODY**

(75) Inventors: **Wayne K Simons**, Kent, WA (US); **F Erik Tuft**, Kenmore, WA (US); **Steven H Hovind**, Bellevue, WA (US); **Gerald Jay Angelo**, Bellevue, WA (US); **Wallace A Peltola**, Sammamish, WA (US); **Daniel R Kieffer**, Kirkland, WA (US)

(73) Assignee: **PACCAR Inc**, Bellevue, WA (US)

(\*\*) Term: **14 Years**

(21) Appl. No.: **29/238,191**

(22) Filed: **Sep. 12, 2005**

(51) **LOC (8) Cl.** ..... **12-16**

(52) **U.S. Cl.** ..... **D12/96; D12/173**

(58) **Field of Classification Search** ..... **D12/173, D12/96, 97; 180/69.2, 89.12, 89.13, 89.67, 180/89.7; 296/183.1**

See application file for complete search history.

(56) **References Cited**

**U.S. PATENT DOCUMENTS**

D291,872 S	9/1987	Simons et al.
D291,982 S	9/1987	Simons et al.
D307,254 S	4/1990	Koske et al.
D307,731 S	5/1990	Kerney et al.
D308,032 S	5/1990	Kerney et al.
D311,711 S	10/1990	Marlowe et al.
D312,609 S	12/1990	Preslik et al.

(Continued)

**OTHER PUBLICATIONS**

Kenworth Truck Company W900 brochure, Kirkland, Wash, 2005.

(Continued)

*Primary Examiner*—Melody N. Brown

(74) *Attorney, Agent, or Firm*—Christensen O'Connor Johnson Kindness PLLC

(57) **CLAIM**

The ornamental design for a truck body, as shown and described.

**DESCRIPTION**

FIG. 1 is a front perspective view of a truck body showing a first embodiment of our new design;

FIG. 2 is a front elevational view of the truck body of FIG. 1;

FIG. 3 is a rear elevational view of the truck body of FIG. 1;

FIG. 4 is a top plan view of the truck body of FIG. 1, the bottom plan view of the truck body of FIG. 1 is unornamented;

FIG. 5 is a right side elevational view of the truck body of FIG. 1;

FIG. 6 is a left side elevational view of the truck body of FIG. 1;

FIG. 7 is a front perspective view of a truck body showing a second embodiment of our new design;

FIG. 8 is a front elevational view of the truck body of FIG. 7;

FIG. 9 is a rear elevational view of the truck body of FIG. 7;

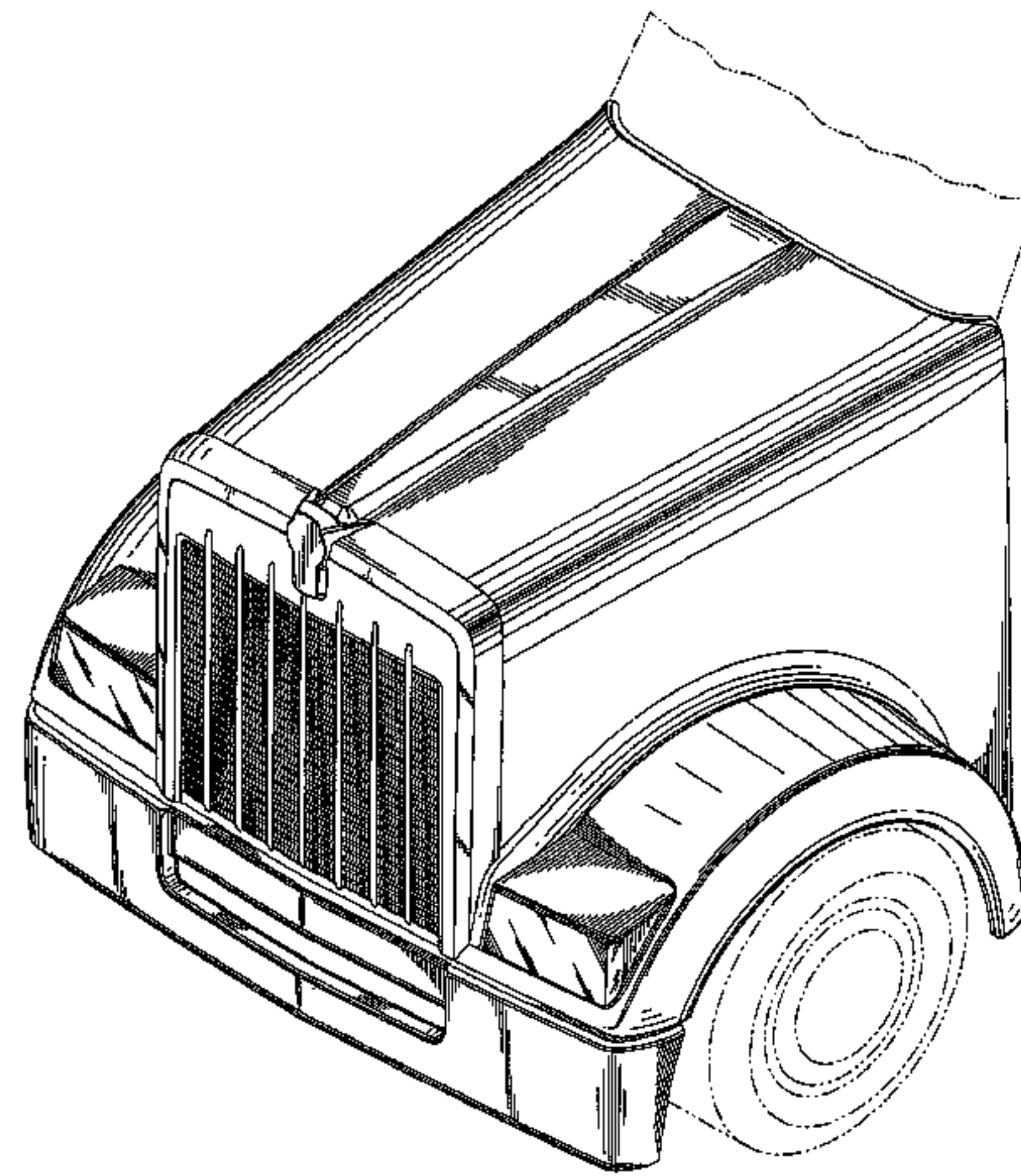
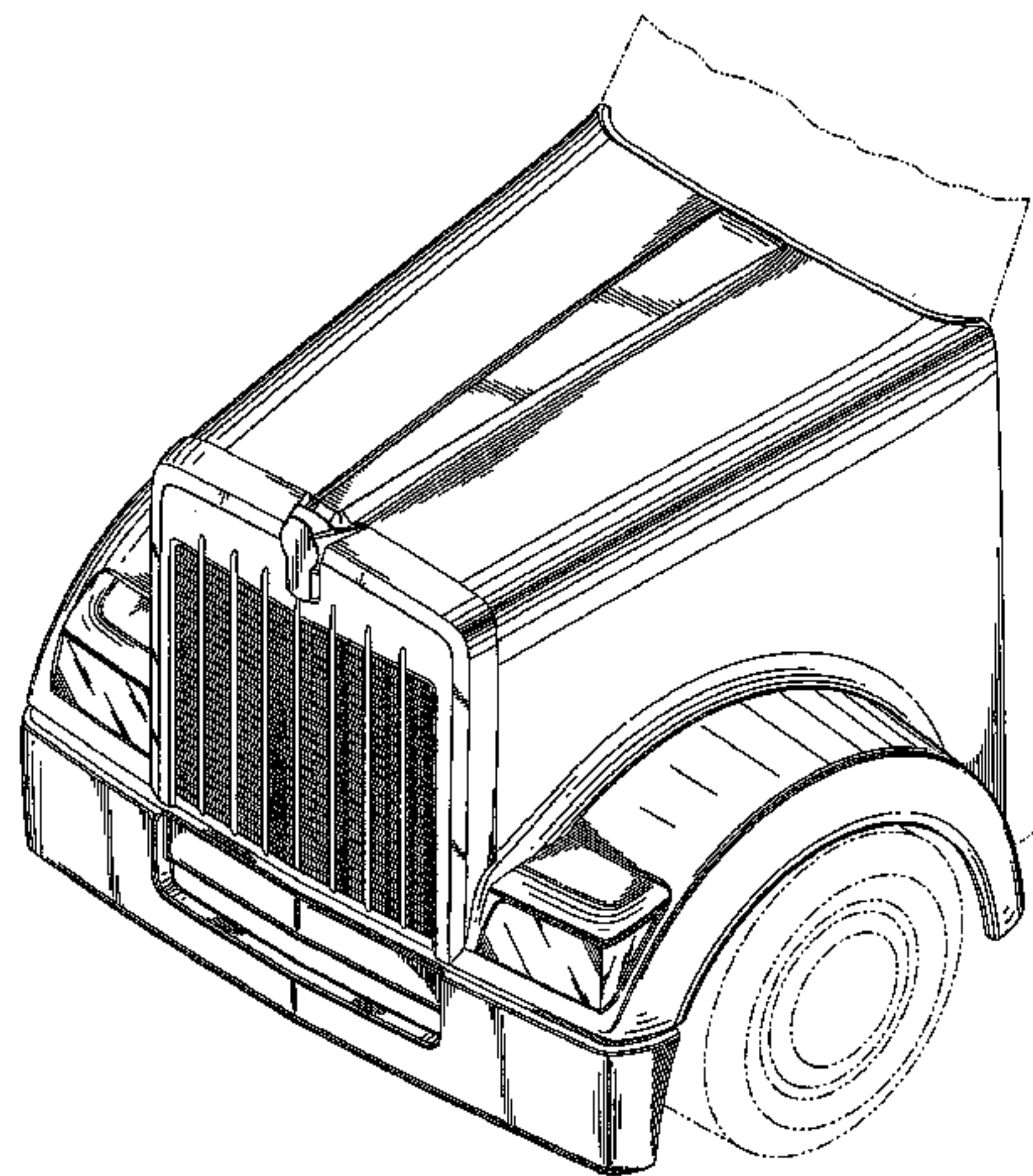
FIG. 10 is a top plan view of the truck body of FIG. 7, the bottom plan view of the truck body of FIG. 7 is unornamented;

FIG. 11 is a right side elevational view of the truck body of FIG. 7; and,

FIG. 12 is a left side elevational view of the truck body of FIG. 7.

The broken lines in the drawings form no part of the claimed design.

**1 Claim, 12 Drawing Sheets**



U.S. PATENT DOCUMENTS

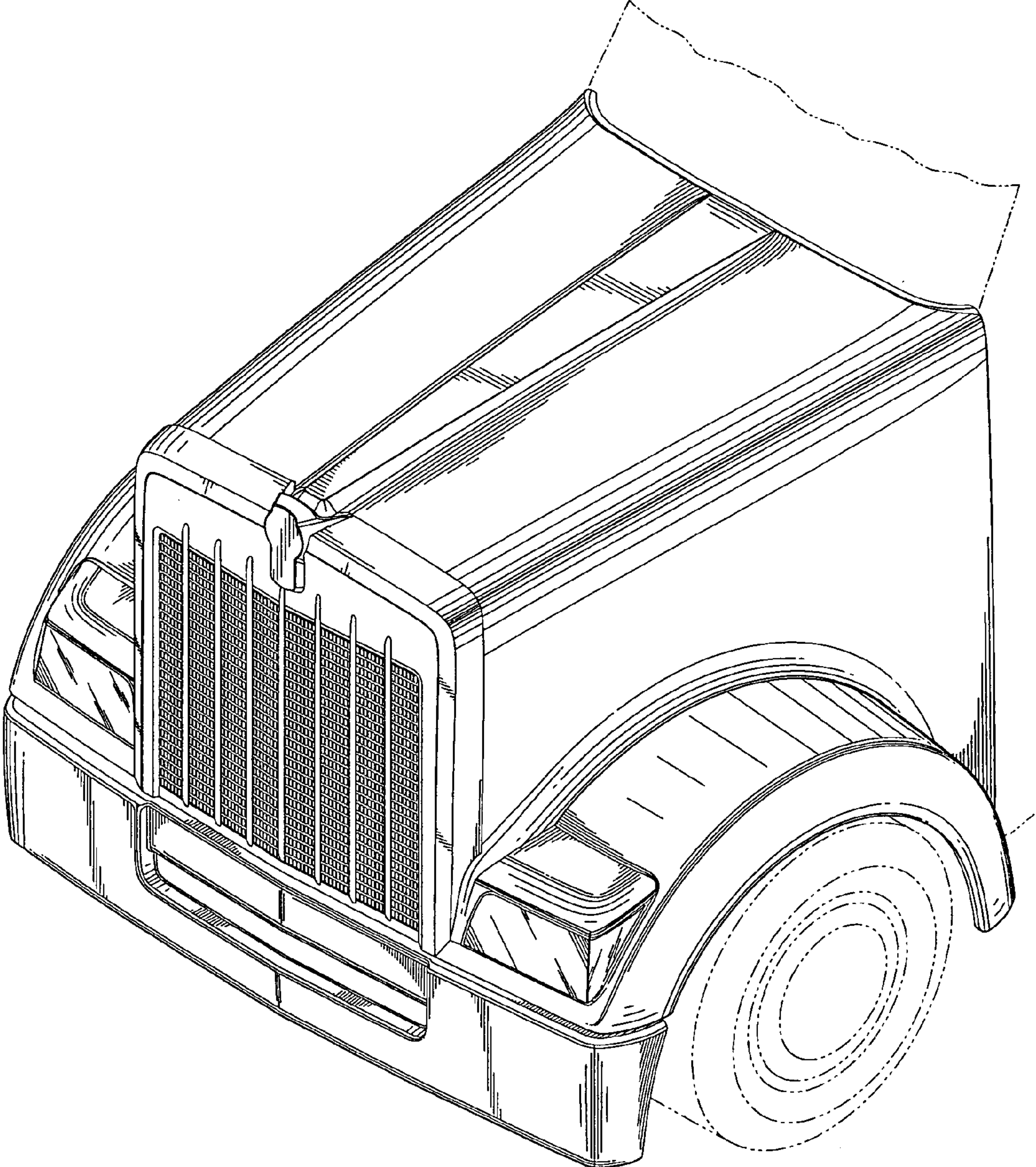
D312,805 S	12/1990	Marlowe et al.	D466,847 S	12/2002	Waskow et al.
D312,810 S	12/1990	Preslik et al.	D470,956 S	2/2003	Horowitz
D313,784 S	1/1991	Marlow et al.	D471,494 S	3/2003	Chan
D313,954 S	1/1991	Fingerle	D475,657 S	6/2003	Wong et al.
D313,966 S	1/1991	Marlowe et al.	D475,663 S	6/2003	Chiang
D316,241 S	4/1991	Ray	D475,664 S	6/2003	Chiang
D319,036 S	8/1991	Fingerle	D476,929 S	7/2003	Dozier et al.
D320,582 S	10/1991	Fingerle	D477,427 S	7/2003	Mazziotti
D320,583 S	10/1991	Simons et al.	D478,027 S	8/2003	Chiang
D329,214 S	9/1992	Marlowe et al.	D478,028 S	8/2003	Chiang
D343,605 S	1/1994	Meryman	D478,300 S	8/2003	Chiang
D343,916 S	2/1994	King et al.	D482,302 S	11/2003	Dozier et al.
D363,561 S	10/1995	Lagaay et al.	D482,993 S	12/2003	Conway et al.
D364,371 S	11/1995	Ray et al.	D483,707 S	12/2003	Satou
D366,638 S	1/1996	Tucker et al.	D484,077 S	12/2003	Conway et al.
D366,640 S	1/1996	Tucker et al.	D488,749 S	4/2004	Ikuma et al.
D381,946 S	8/1997	Delashaw et al.	D490,560 S	5/2004	Zyskowski
D381,949 S	8/1997	Barrett, Jr. et al.	D491,848 S	6/2004	Metros et al.
D382,841 S	8/1997	Norwood et al.	D492,627 S	7/2004	Metros et al.
D382,844 S	8/1997	Norwood et al.	D492,628 S	7/2004	Bond et al.
D384,019 S	9/1997	Meryman et al.	D493,552 S	7/2004	Metros et al.
D389,108 S	1/1998	Norwood et al.	D493,902 S	8/2004	Hoelzel et al.
D391,212 S	2/1998	Meryman et al.	D494,293 S	8/2004	Pfeiffer
D395,848 S	7/1998	Meryman et al.	D494,898 S	8/2004	Metros et al.
D395,860 S	7/1998	Meryman et al.	D494,900 S	8/2004	Satou
D403,636 S	1/1999	Meryman et al.	D495,071 S	8/2004	Pfeiffer
D405,037 S	2/1999	Meryman et al.	D497,577 S	10/2004	Metros et al.
D411,140 S	6/1999	Meryman et al.	D497,581 S	10/2004	Conway et al.
D411,494 S	6/1999	Meryman et al.	D498,010 S	11/2004	Pfeiffer et al.
D412,874 S	8/1999	Meryman et al.	D498,314 S	11/2004	Pfeiffer et al.
D414,571 S	9/1999	Schneider et al.	D498,716 S	11/2004	Maeda et al.
D421,817 S	3/2000	Tucker et al.	D499,496 S	12/2004	Papke et al.
D422,251 S	4/2000	Bader et al.	D499,822 S	12/2004	Pfeiffer
D423,429 S	4/2000	Hickman et al.	D500,565 S	1/2005	Hoelzel et al.
D423,990 S	5/2000	Meryman et al.	D502,897 S	3/2005	Delashaw et al.
D424,489 S	5/2000	Damon et al.	D502,901 S	3/2005	Delashaw et al.
D425,450 S	5/2000	Barraclough et al.	D502,904 S	3/2005	Delashaw et al.
D425,835 S	5/2000	Cook et al.	D504,186 S	4/2005	Pfeiffer
D426,905 S	6/2000	Cook et al.	D504,642 S *	5/2005	Perfetti et al. .... D12/173
D429,669 S	8/2000	Cook et al.	D504,850 S	5/2005	Gunter et al.
D431,806 S	10/2000	Damon et al.	D512,666 S	12/2005	Chiang
D432,492 S	10/2000	Waskow et al.	D514,483 S	2/2006	Chiang
D433,967 S	11/2000	Delashaw et al.	D518,761 S	4/2006	Chiang
D433,980 S	11/2000	Conway et al.	D519,067 S	4/2006	Steere et al.
D433,981 S	11/2000	Davis et al.			
D434,347 S	11/2000	Damon et al.			
D434,348 S	11/2000	Delashaw et al.			
D434,358 S	11/2000	Conway et al.			
D435,816 S	1/2001	Delashaw et al.			
D436,563 S	1/2001	Delashaw et al.			
D436,894 S	1/2001	Barraclough et al.			
D437,258 S	2/2001	Meryman et al.			
D437,570 S	2/2001	Meryman et al.			
D442,132 S	5/2001	Weidhase			
D443,853 S	6/2001	Barraclough et al.			
D446,175 S	8/2001	Hoyle, Jr.			
D450,277 S *	11/2001	Onopa ..... D12/173			
D458,397 S	6/2002	Horowitz			

OTHER PUBLICATIONS

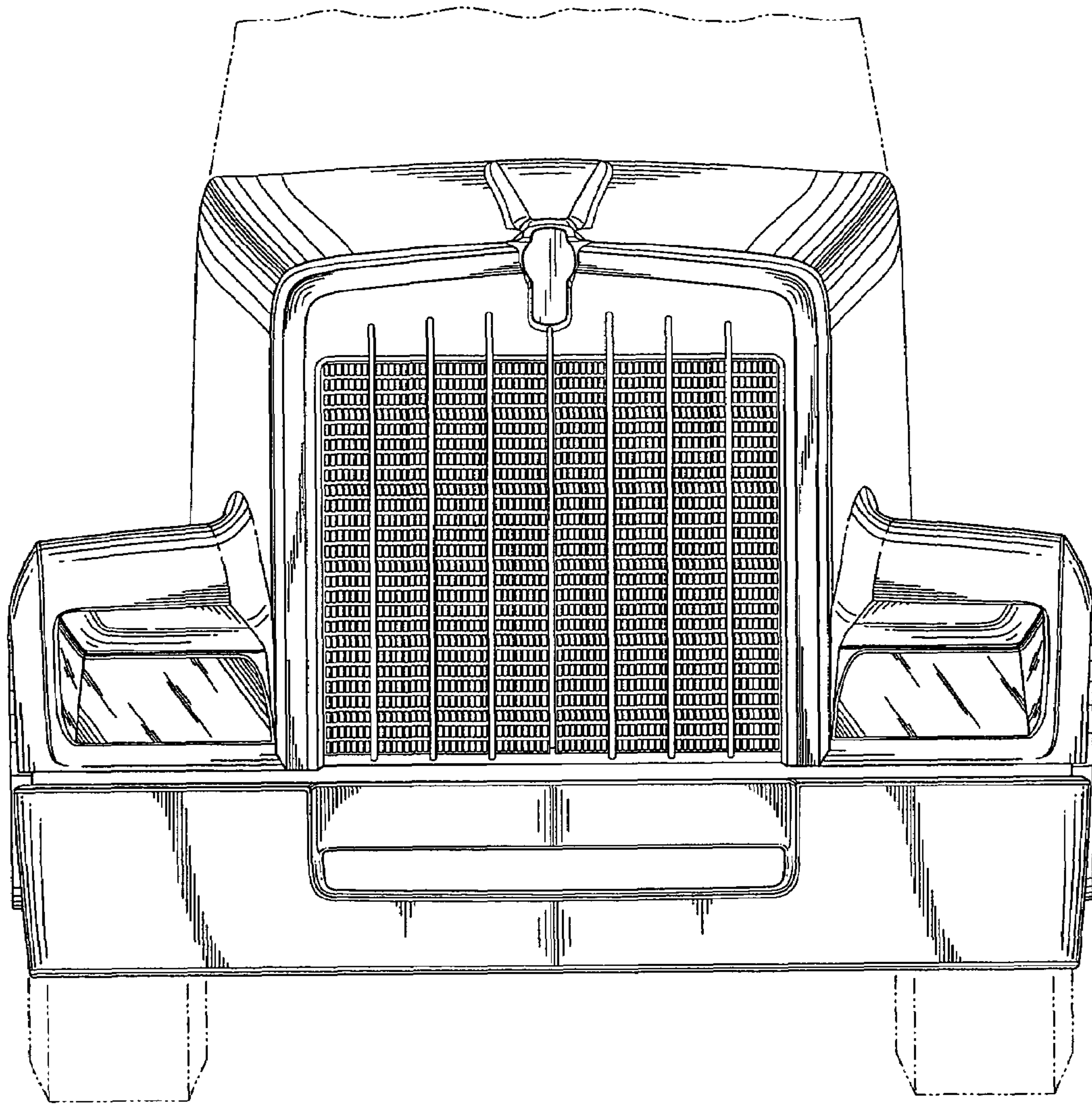
Kenworth Truck Company W900 brochure, Kirkland, Wash, 2002.  
 Kenworth Truck Company W900 brochure, Kirkland, Wash, 1996.  
 Kenworth Truck Company T2000 brochure, Kirkland, Wash, 2005.  
 Kenworth Truck Company T2000 brochure, Kirkland, Wash, 2002.  
 Kenworth Truck Company T800 brochure, Kirkland, Wash, 2005.  
 Kenworth Truck Company T800 brochure, Kirkland, Wash, 2003.  
 Kenworth Truck Company T800 brochure, Kirkland, Wash, 2002.  
 Kenworth Truck Company T600 brochure, Kirkland, Wash, 2005.  
 Kenworth Truck Company T600 brochure, Kirkland, Wash, 2002.  
 Kenworth Truck Company T600 brochure, Kirkland, Wash, 1996.  
 Kenworth Truck Company T300 brochure, Kirkland, Wash, 2005.  
 Kenworth Truck Company T300 brochure, Kirkland, Wash, 2001.

\* cited by examiner

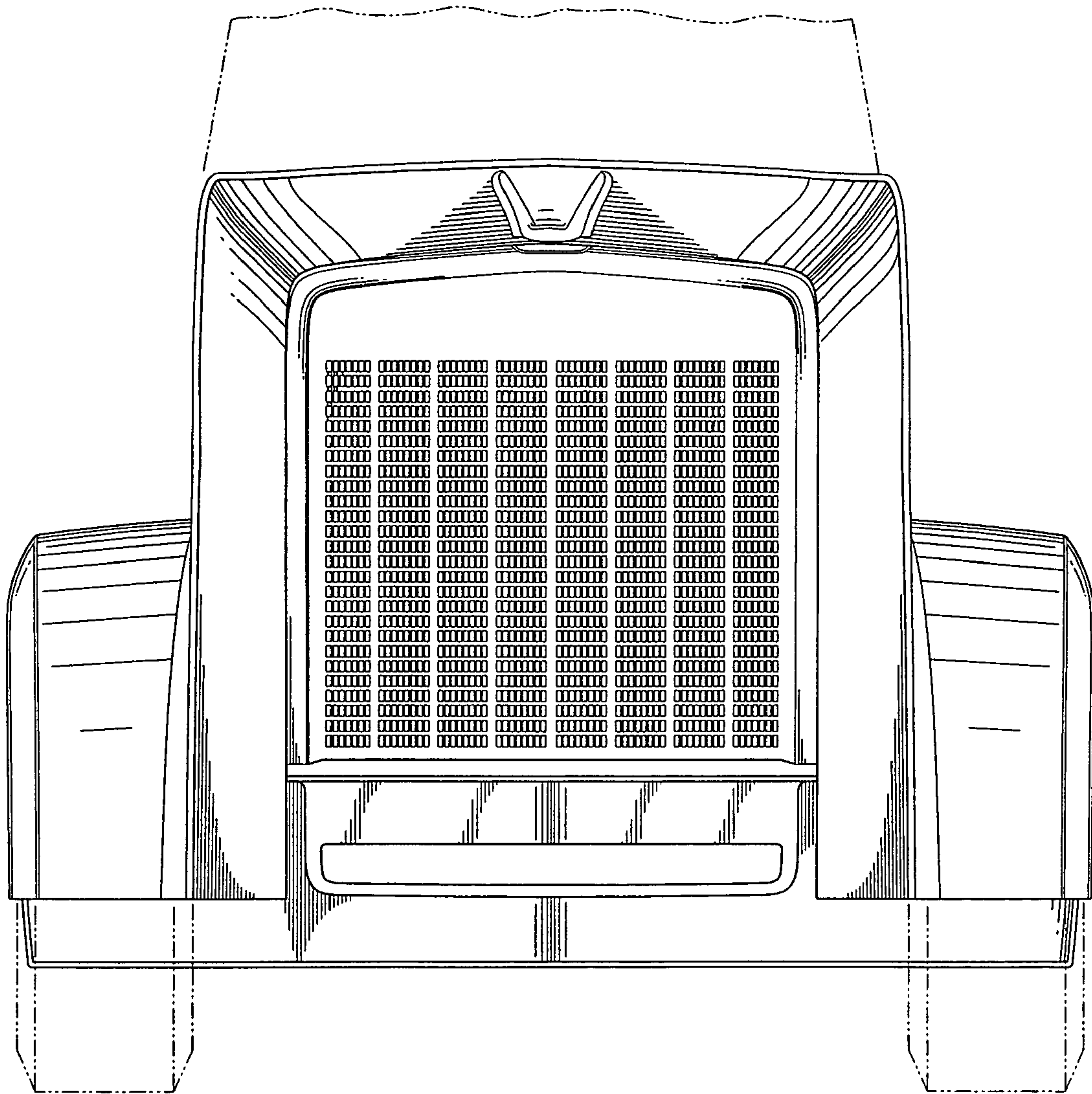




*Fig. 1.*

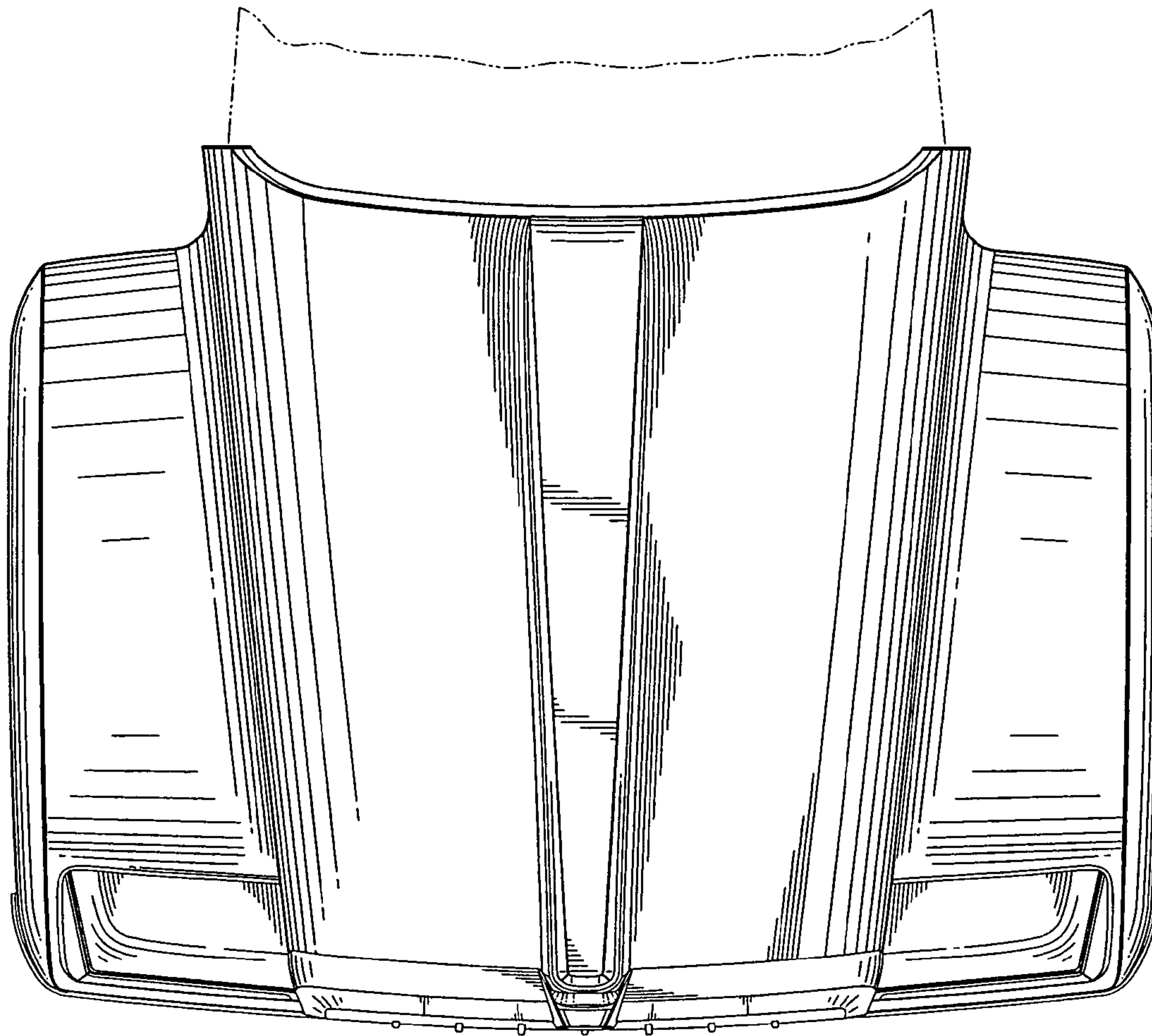


*Fig. 2.*

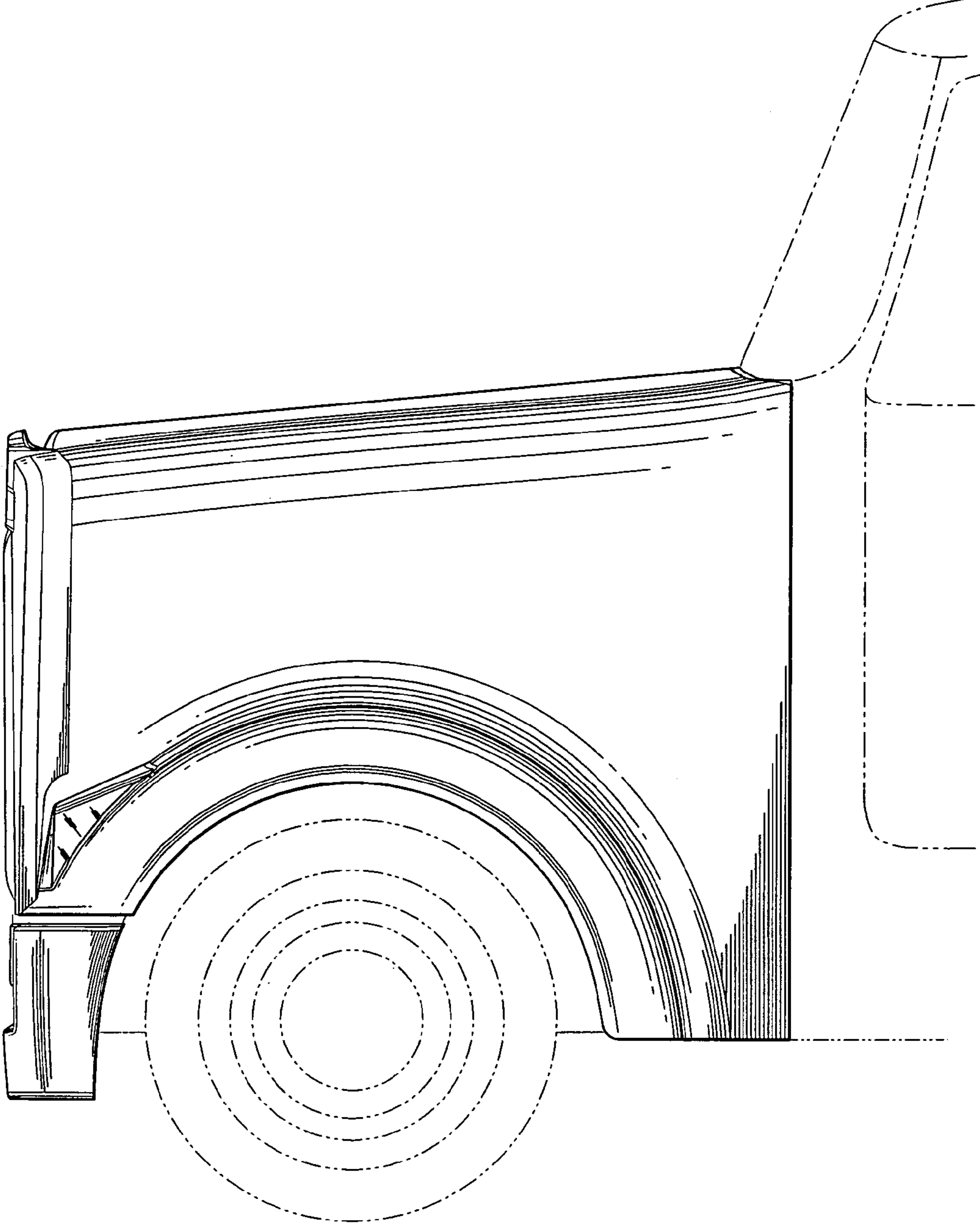


*Fig. 3.*

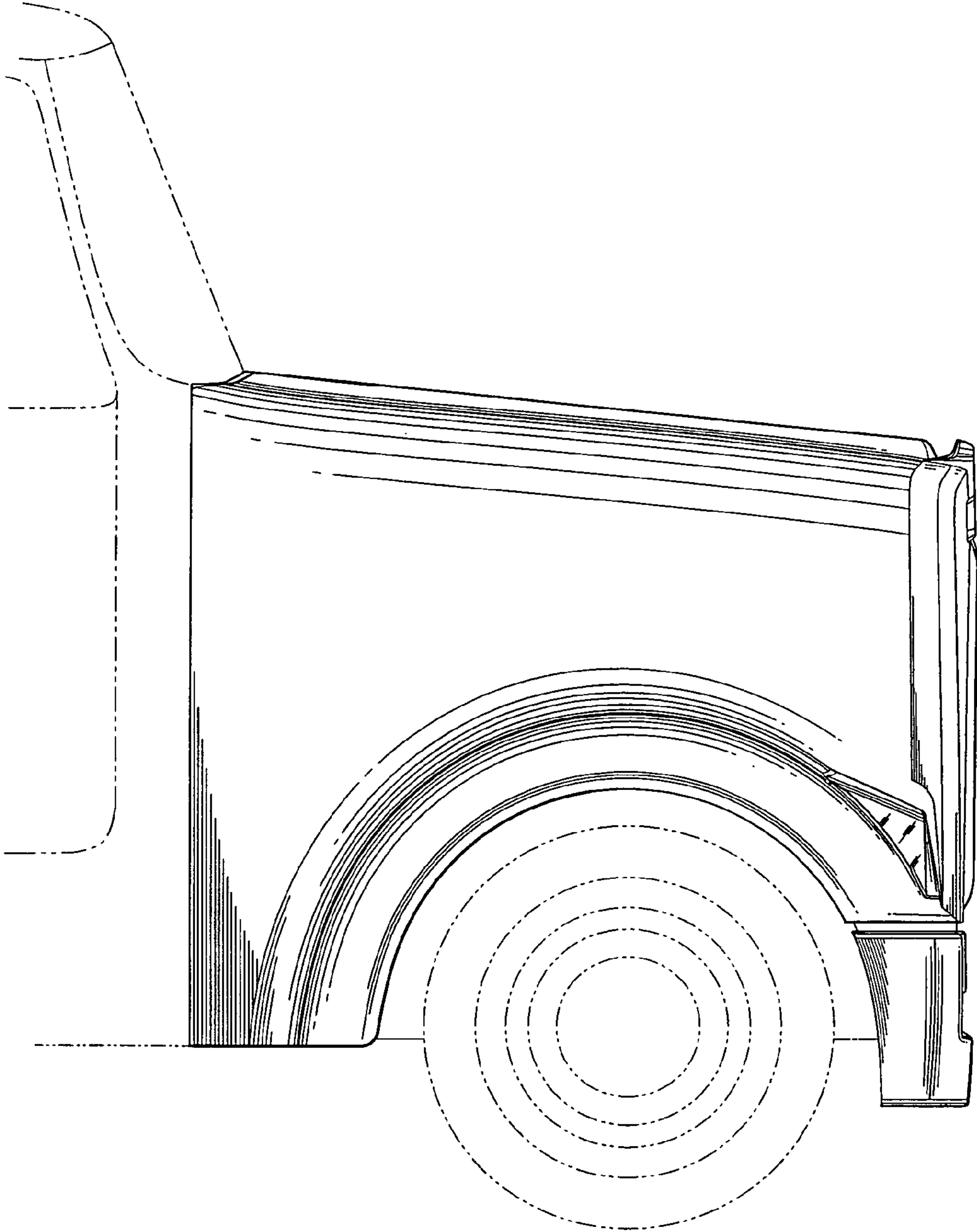




*Fig.4.*

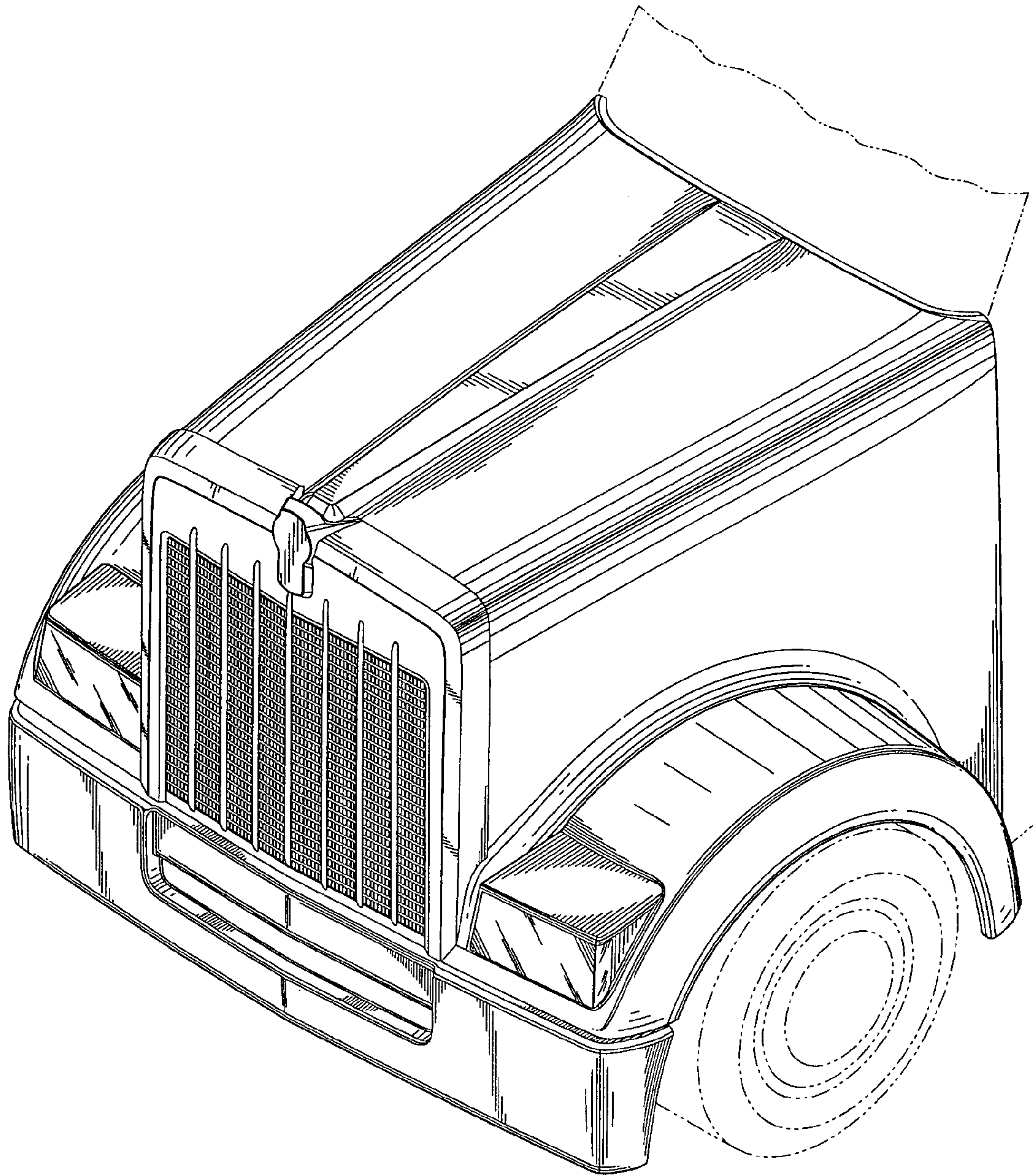


*Fig. 5.*

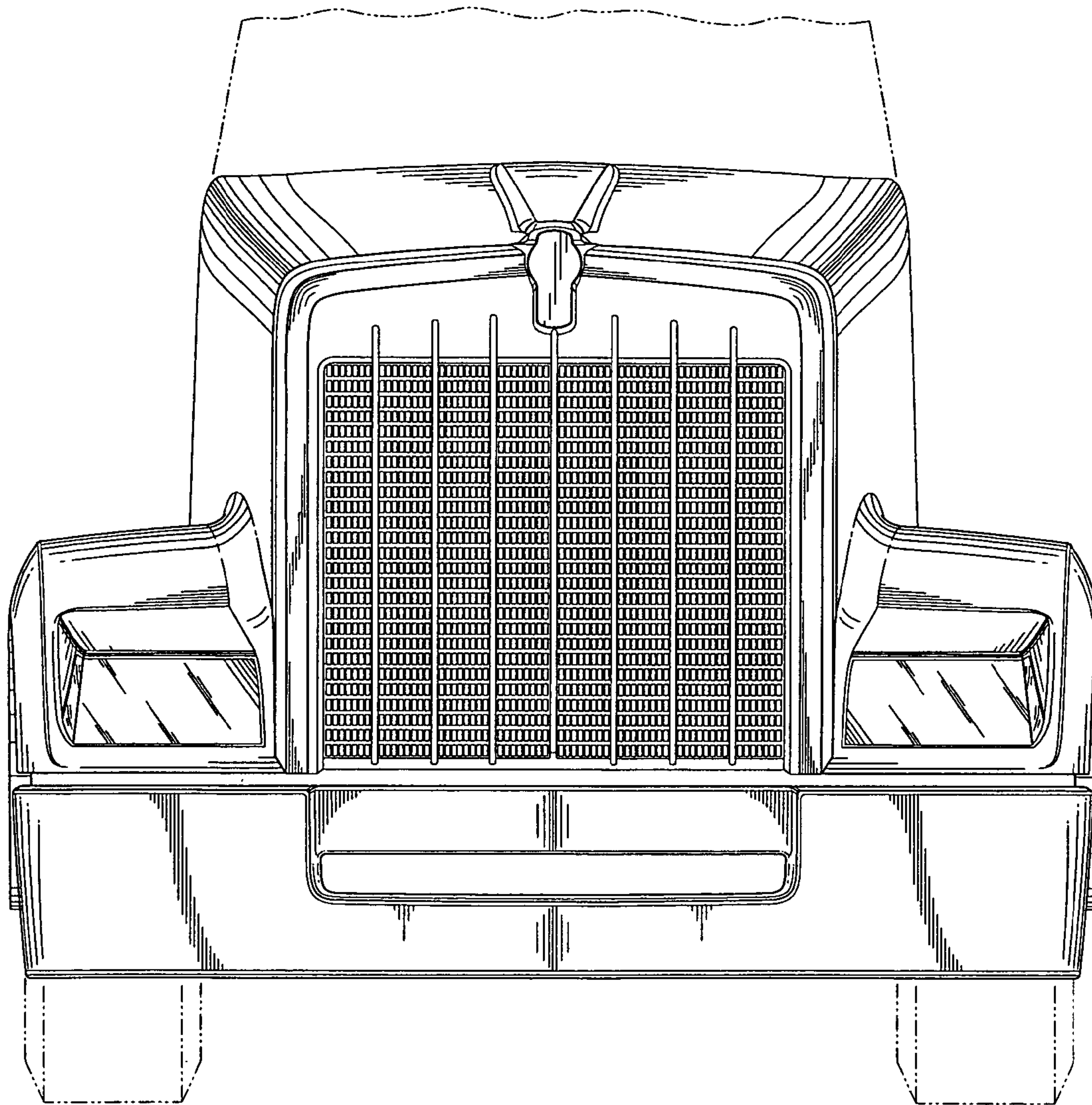


*Fig. 6.*

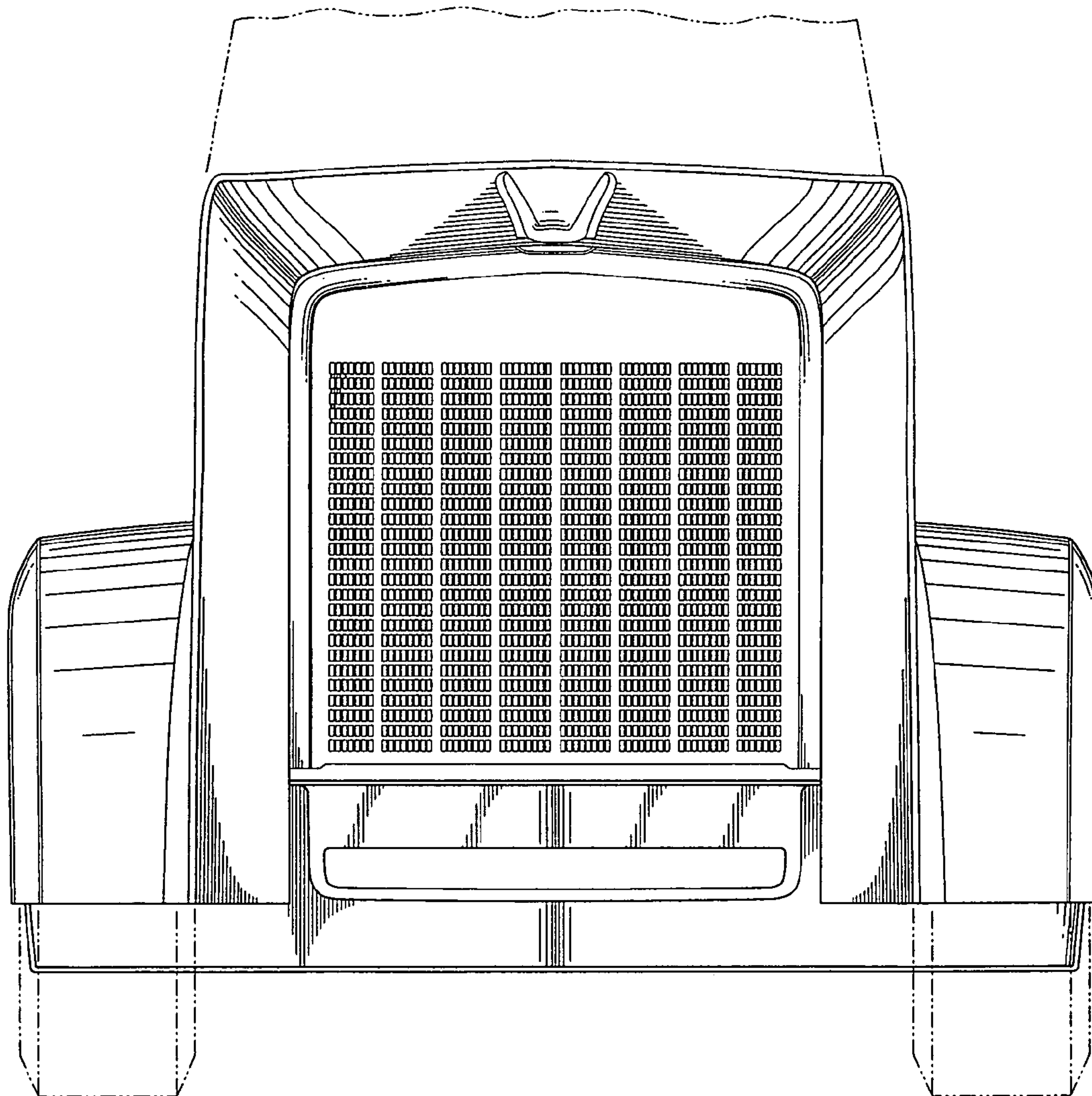




*Fig. 7.*

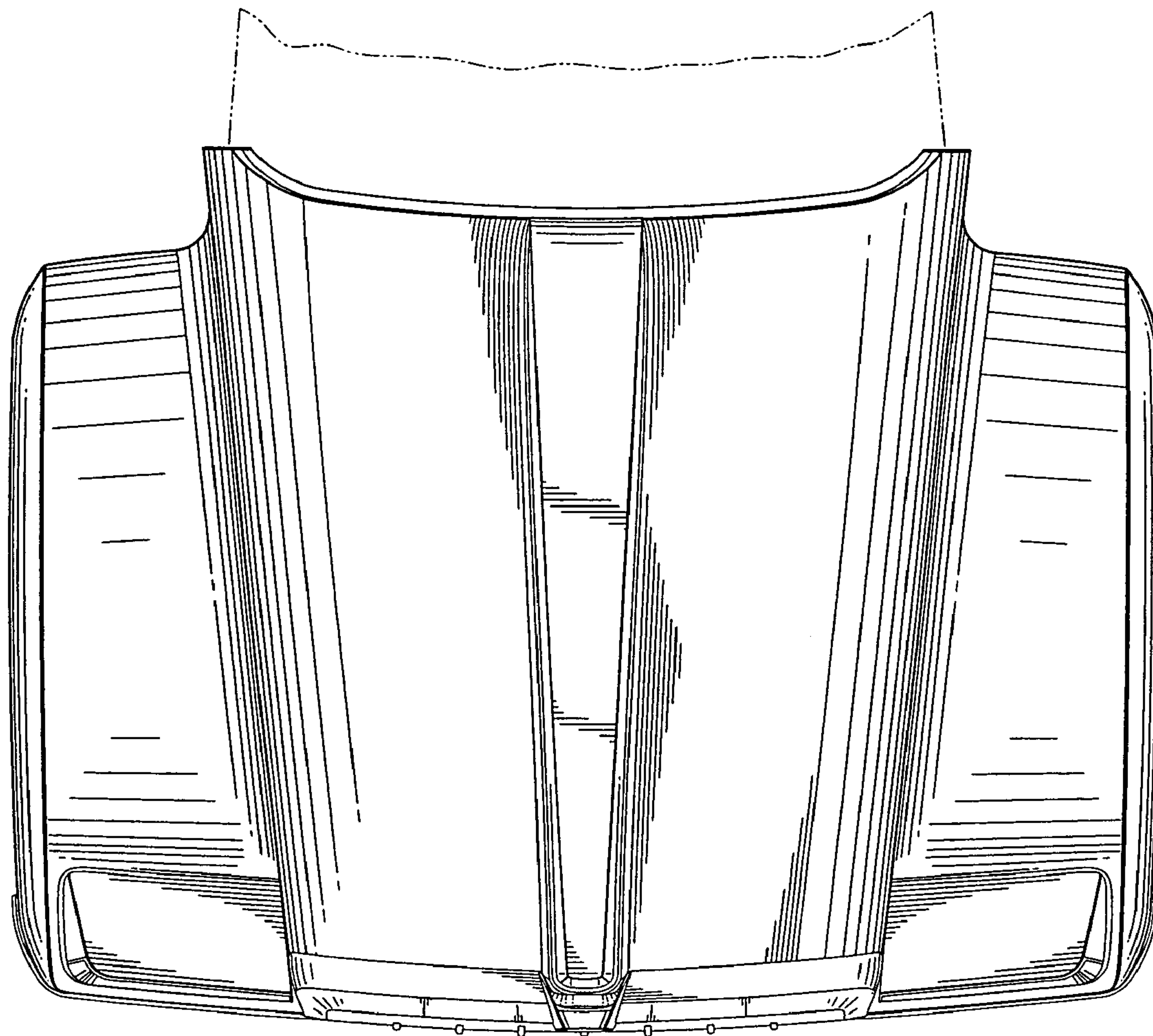


*Fig. 8.*

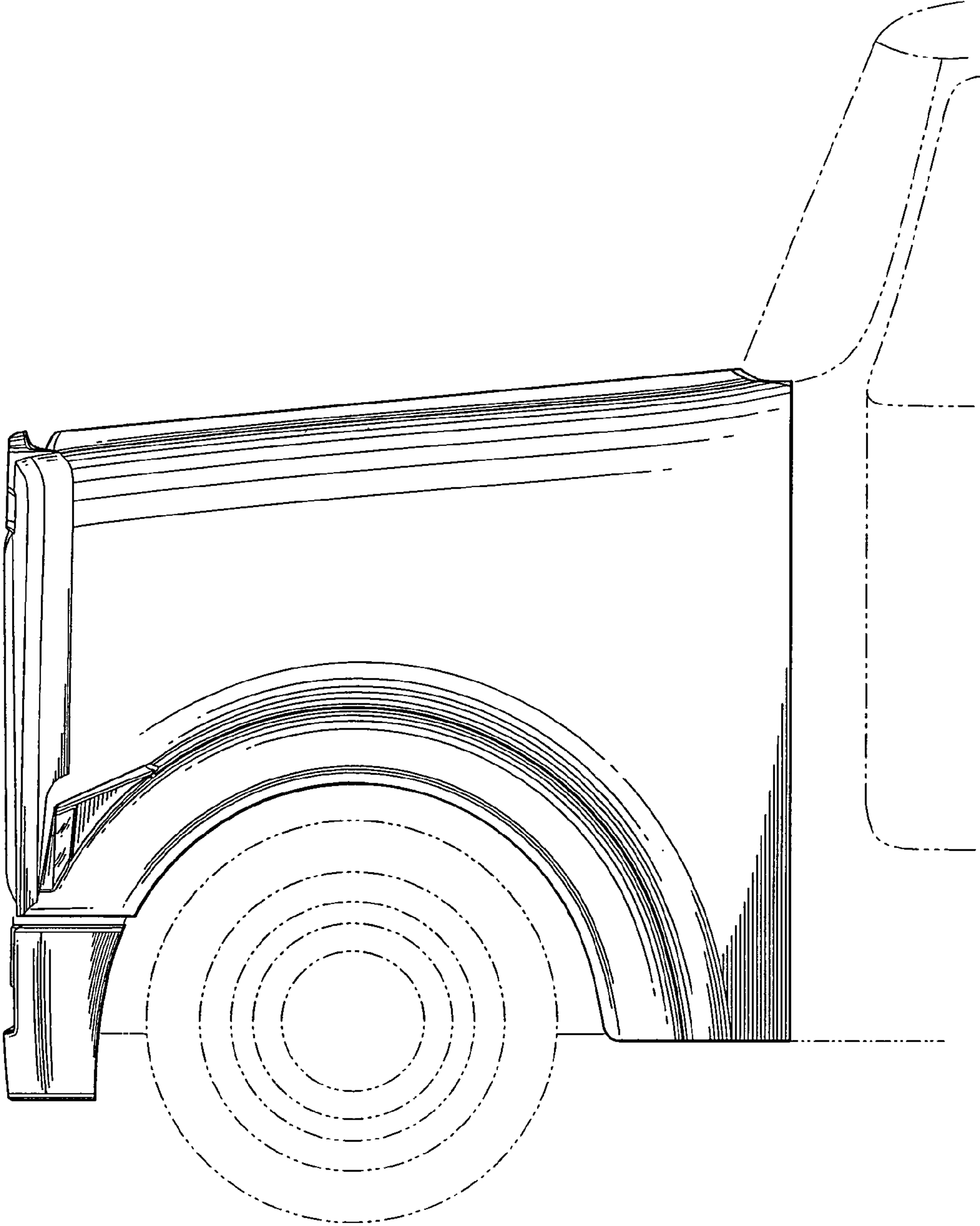


*Fig. 9.*

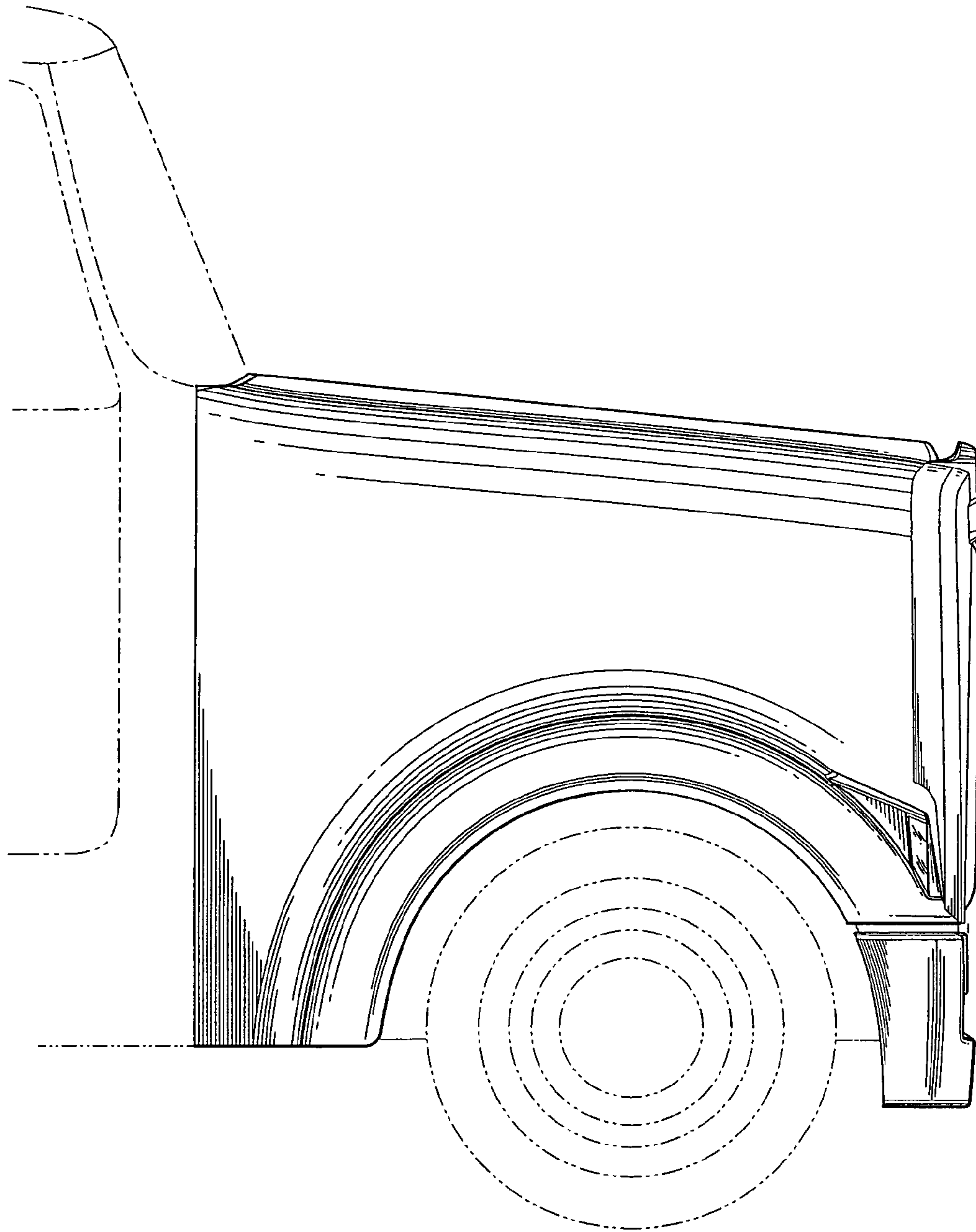




*Fig.10.*



*Fig. 11.*



*Fig.12.*