



US00D562956S

(12) **United States Design Patent**  
**Martinez et al.**

(10) **Patent No.:** **US D562,956 S**

(45) **Date of Patent:** **\*\* Feb. 26, 2008**

(54) **EVAPORATOR**

(75) Inventors: **Guillermo Ivan Martinez**, Davie, FL (US); **Robert Fellows**, Park Ridge, NJ (US); **Jeffrey Lawrence Stern**, Rancho Santa Margarita, CA (US); **James Edward Bargmann**, Midland Park, NJ (US)

(73) Assignee: **Menshen USA**, Waldwick, NJ (US)

(\*\*) Term: **14 Years**

(21) Appl. No.: **29/242,492**

(22) Filed: **Nov. 12, 2005**

(51) **LOC (8) Cl.** ..... **28-99**

(52) **U.S. Cl.** ..... **D23/366**

(58) **Field of Classification Search** ..... 261/DIG. 17, 261/DIG. 42, DIG. 65, DIG. 88, DIG. 89; D23/355-369; D28/5, 6; 392/386, 390, 392/392, 393, 394, 401; 239/34, 35, 37, 239/41, 42, 43, 53-58, 60, 136, 326; D9/503, D9/537, 545

See application file for complete search history.

(56) **References Cited**

**U.S. PATENT DOCUMENTS**

- D128,153 S \* 7/1941 Arnold ..... D9/500
- 2,775,006 A \* 12/1956 Kranc ..... 422/125
- D205,556 S \* 8/1966 Plochman ..... D9/505
- D271,091 S \* 10/1983 Peterson ..... D11/153
- D288,842 S \* 3/1987 Kwiatkowski ..... D23/366
- D289,678 S \* 5/1987 Kwiatkowski ..... D23/367

- D392,032 S \* 3/1998 Zaragoza et al. .... D23/369
- 5,891,400 A \* 4/1999 Ansari et al. .... 422/125
- D447,256 S \* 8/2001 Ratia ..... D26/9
- D448,466 S \* 9/2001 Zaragoza et al. .... D23/366
- D449,877 S \* 10/2001 Delmenico et al. .... D23/356
- D454,190 S \* 3/2002 Trocola ..... D23/366
- 6,419,122 B1 \* 7/2002 Chown ..... 222/162
- D483,671 S \* 12/2003 Pinnavaia ..... D9/500
- D502,101 S \* 2/2005 Kerman ..... D9/505
- D509,893 S \* 9/2005 Sevy ..... D23/366
- D544,084 S \* 6/2007 Michaels et al. .... D23/366
- D547,850 S \* 7/2007 Michaels et al. .... D23/366

\* cited by examiner

*Primary Examiner*—Sandra Snapp

(57) **CLAIM**

The ornamental design for an evaporator, as shown and described.

**DESCRIPTION**

FIG. 1 is a perspective view of the evaporator showing our new design;

FIG. 2 is a front view thereof;

FIG. 3 is a rear view thereof;

FIG. 4 is a top view thereof;

FIG. 5 is a bottom view thereof;

FIG. 6 is front view of the evaporator in the fully open position; and,

FIG. 7 is a side view of the evaporator in the fully open position.

**1 Claim, 4 Drawing Sheets**

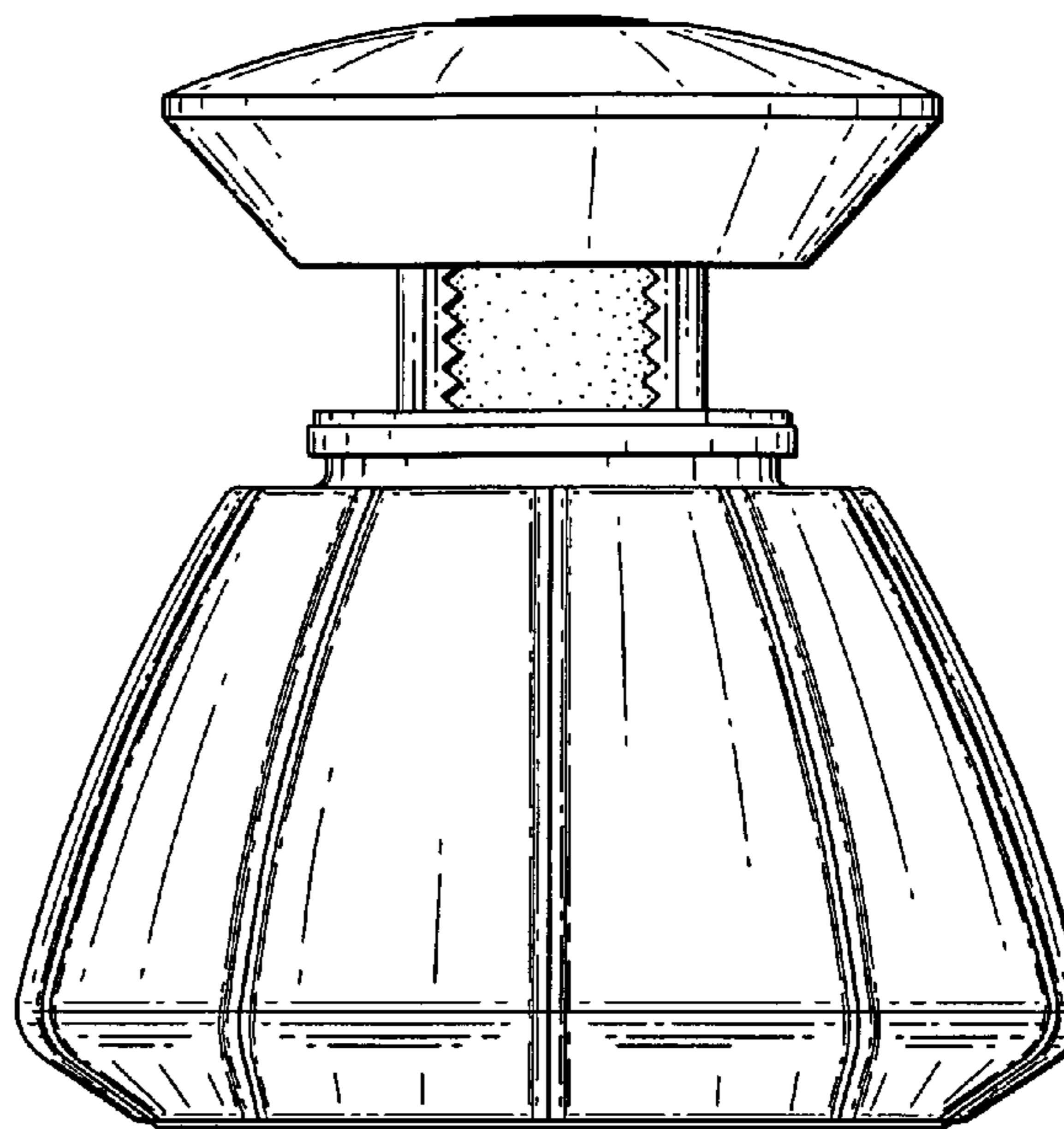
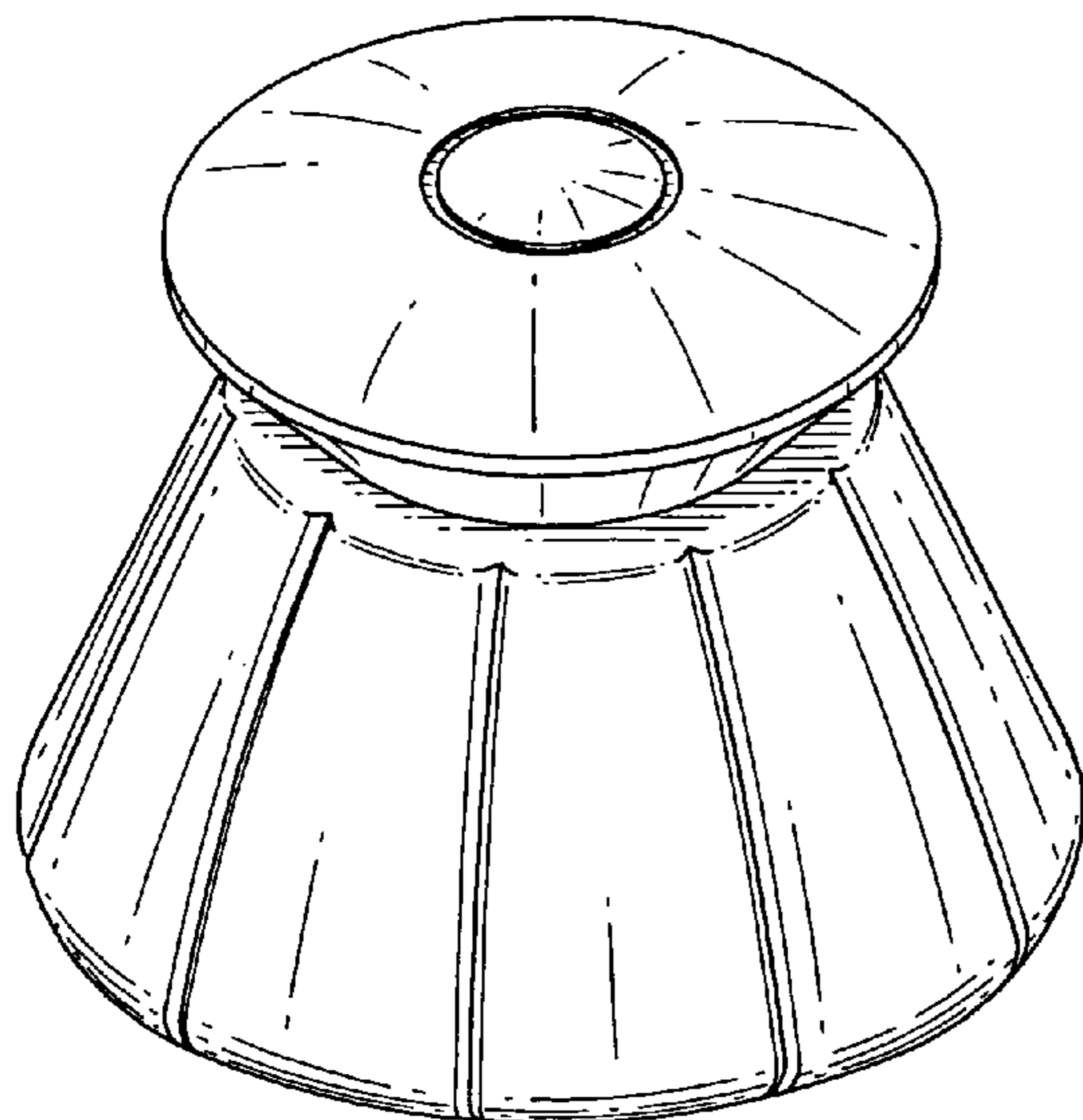

*FIG. 1*

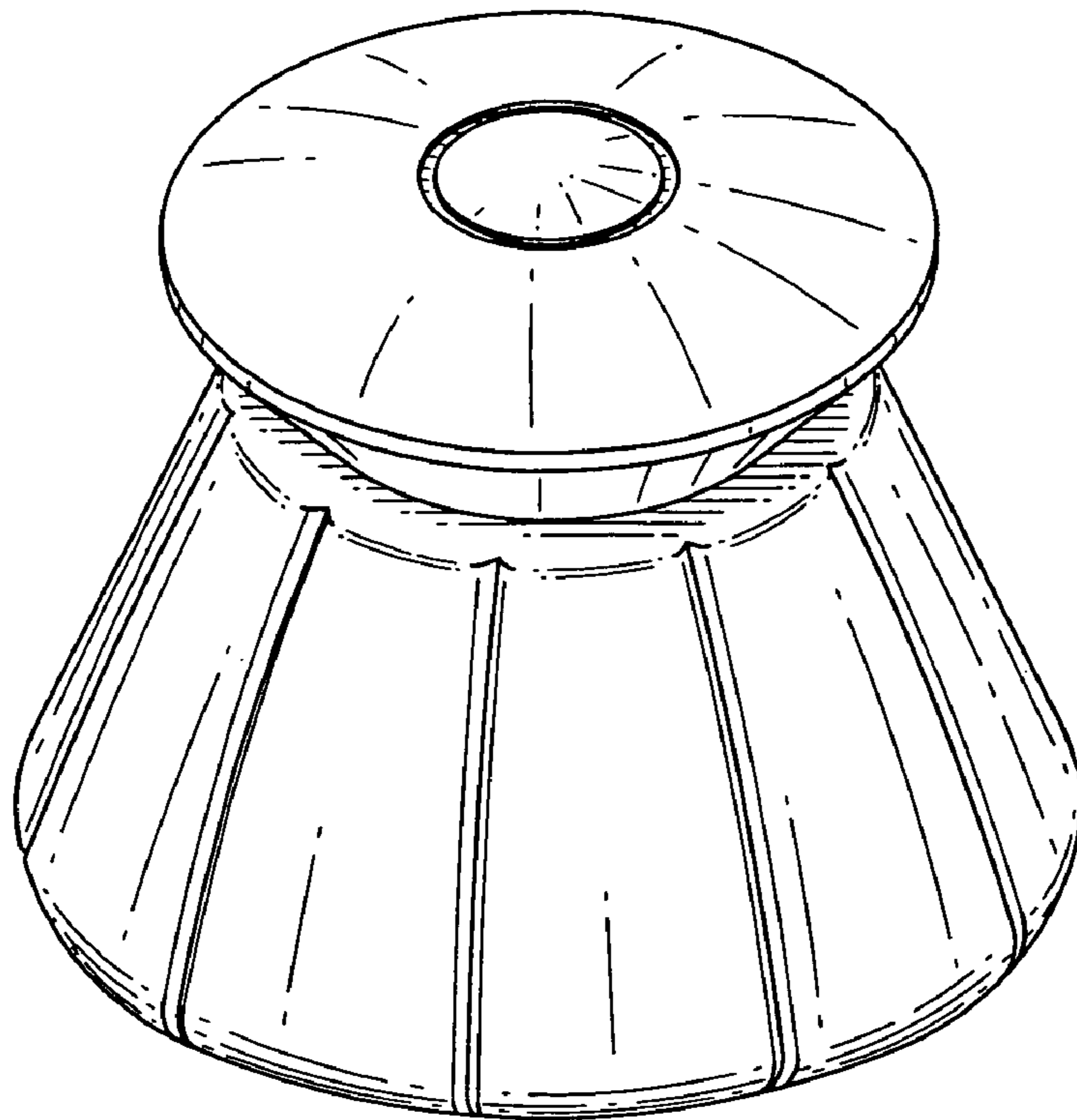

*FIG. 2*

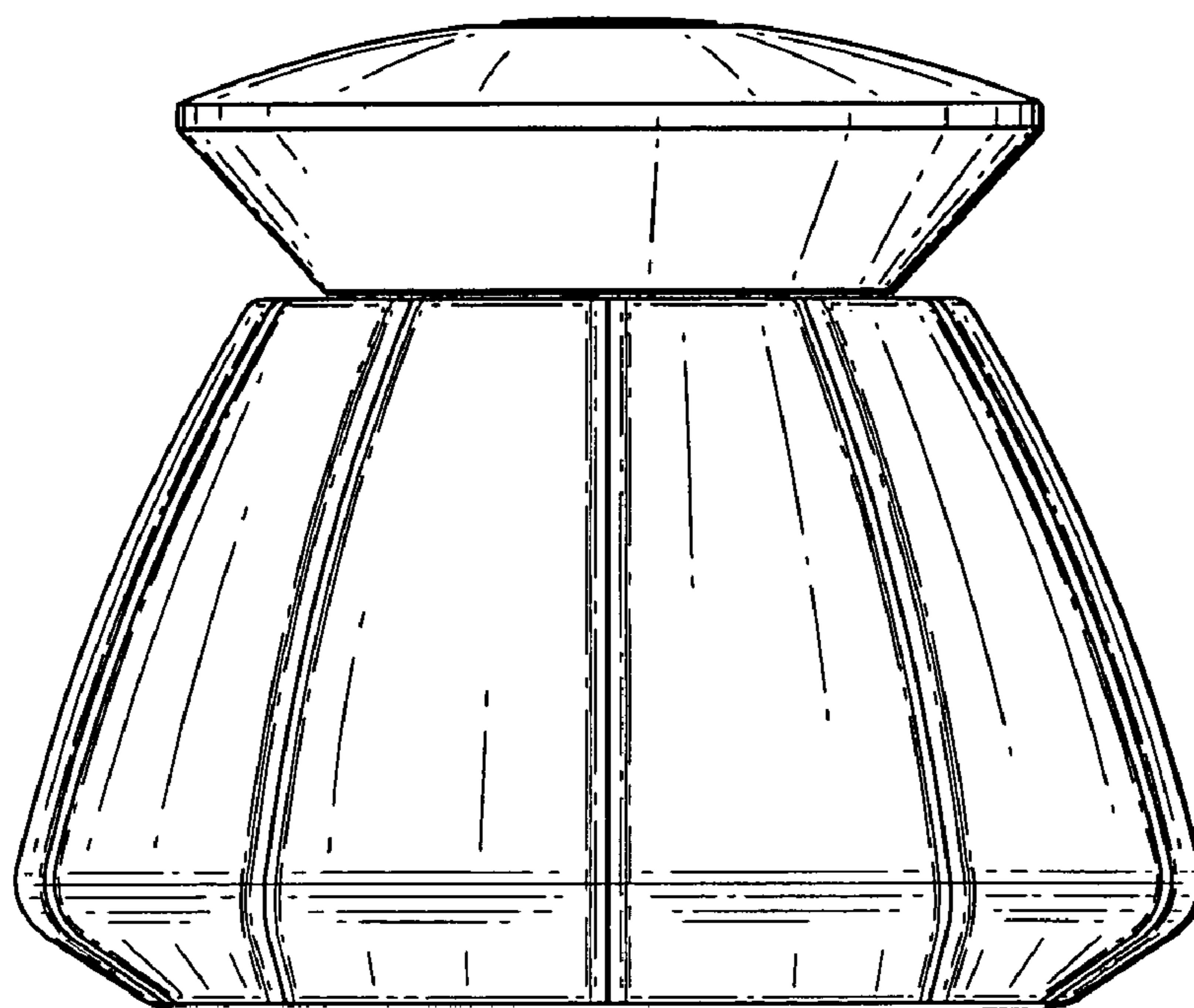

*FIG. 3*

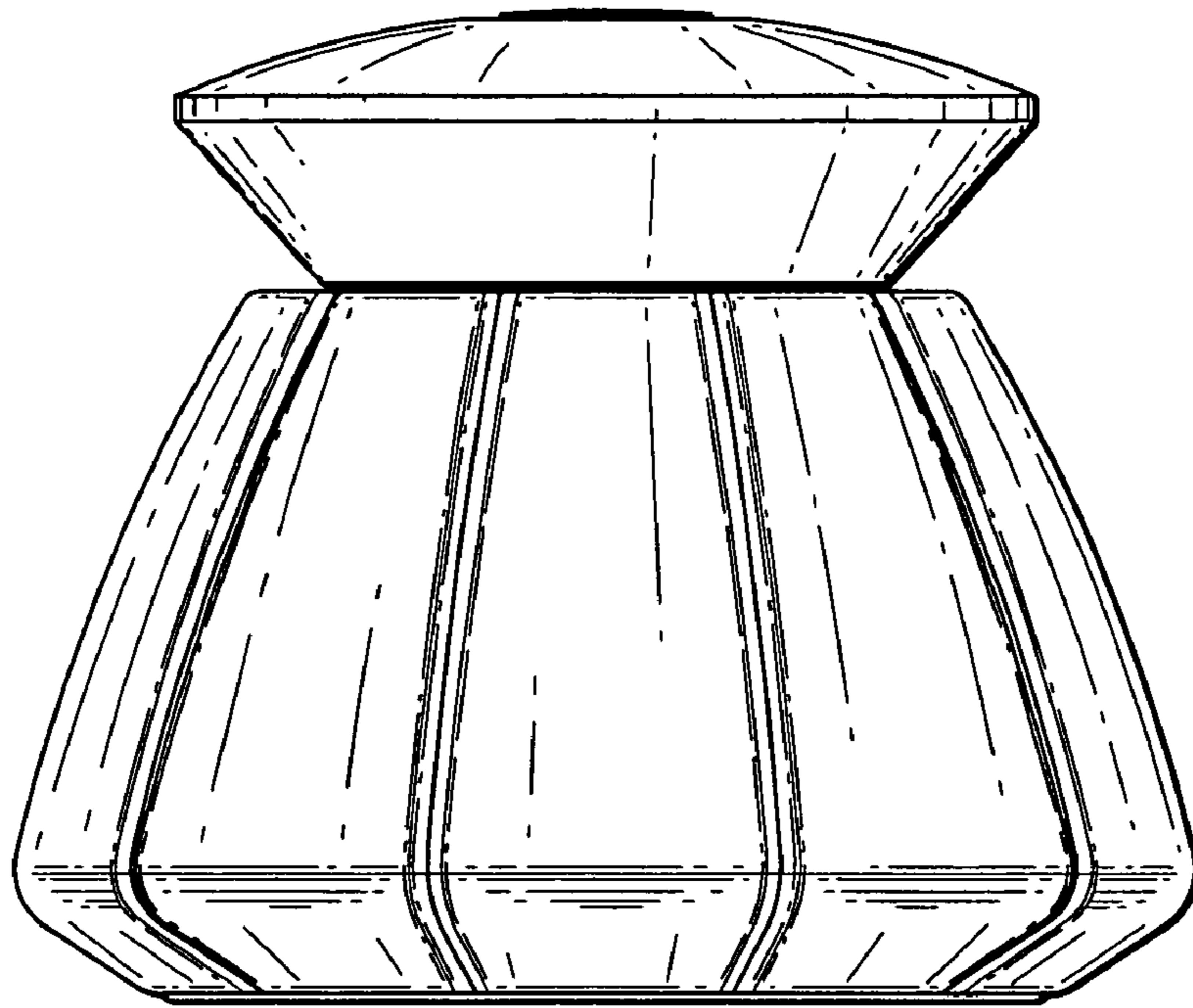

*FIG. 4*

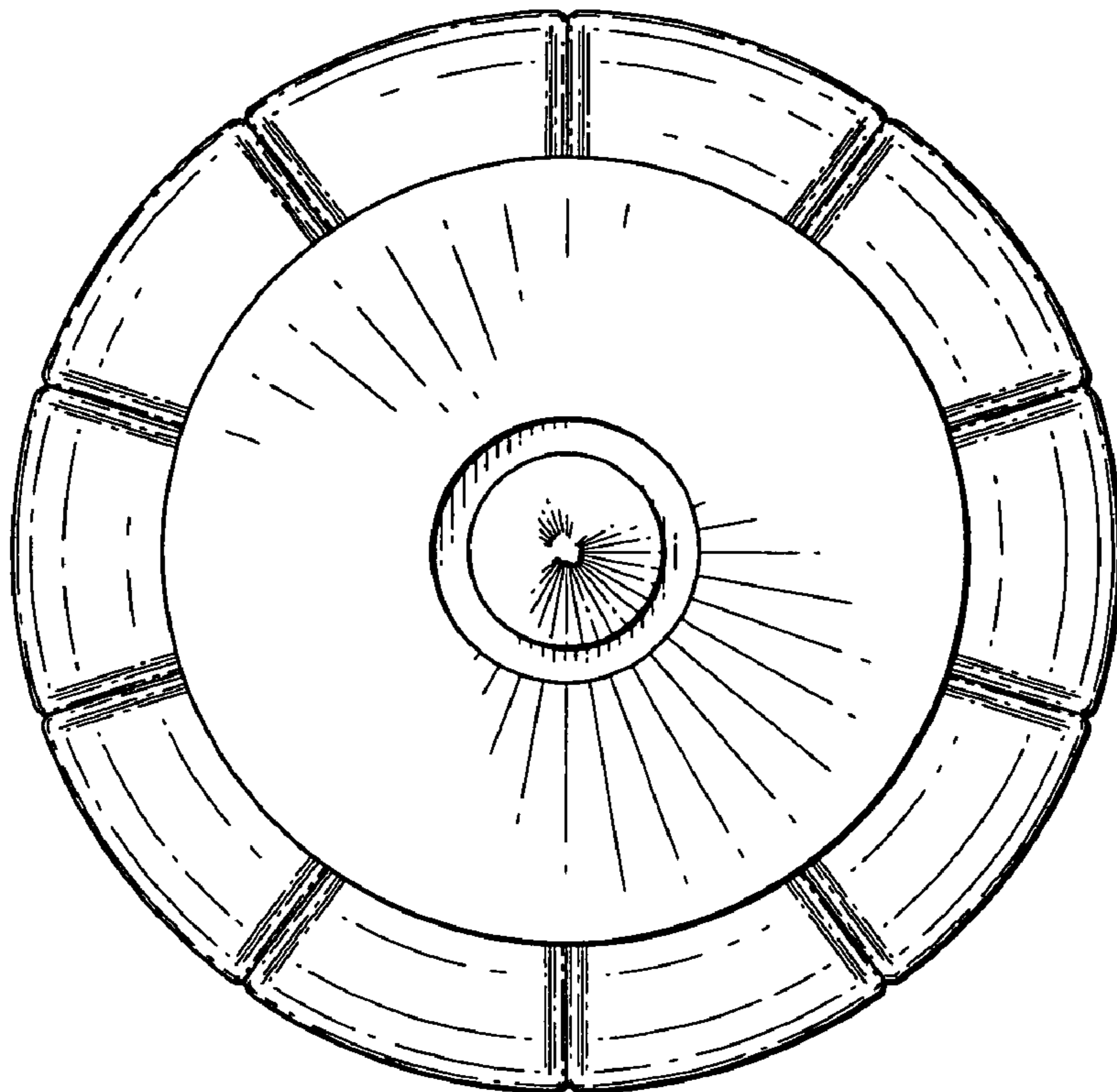



**FIG. 5**

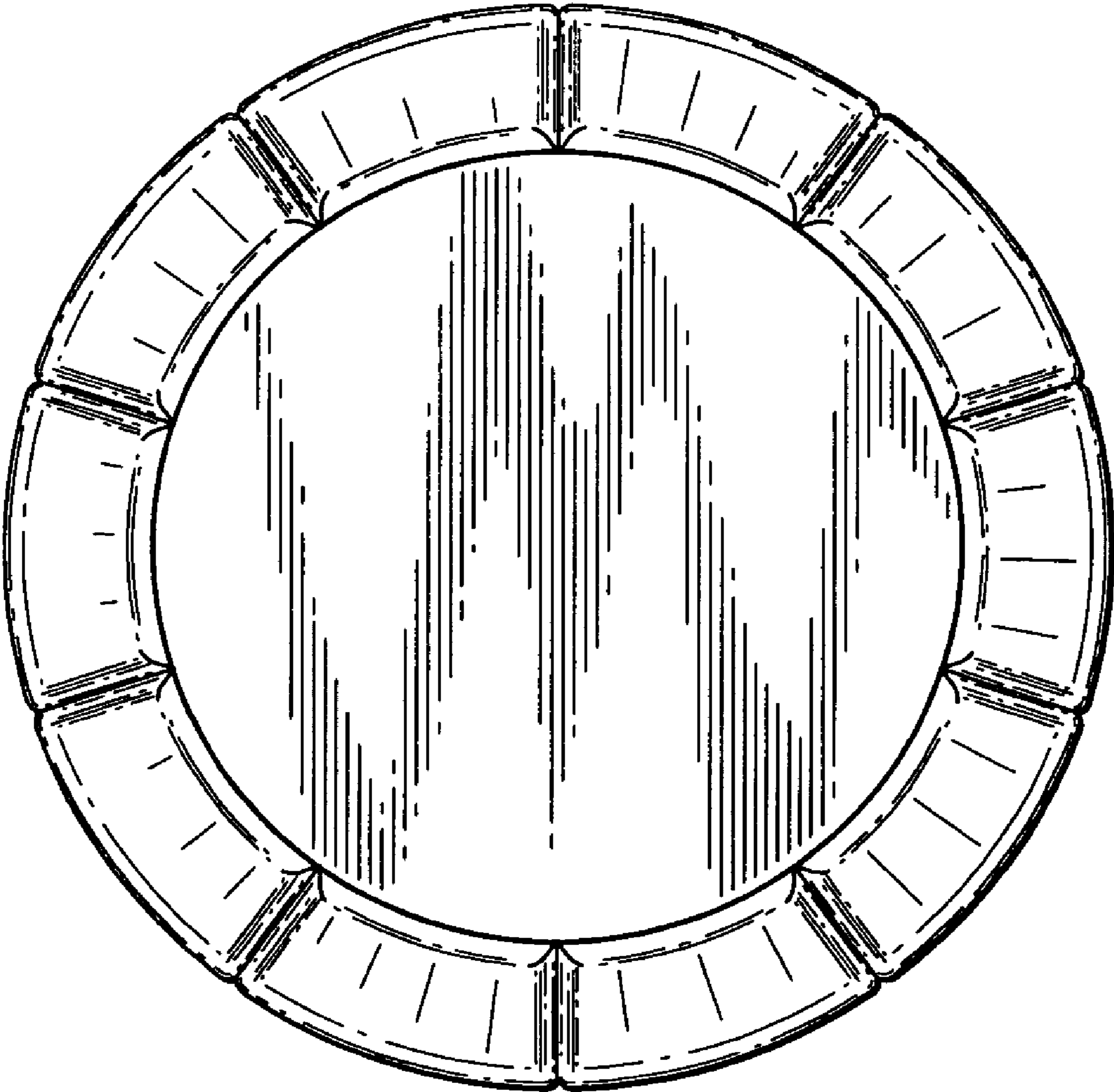

FIG. 6

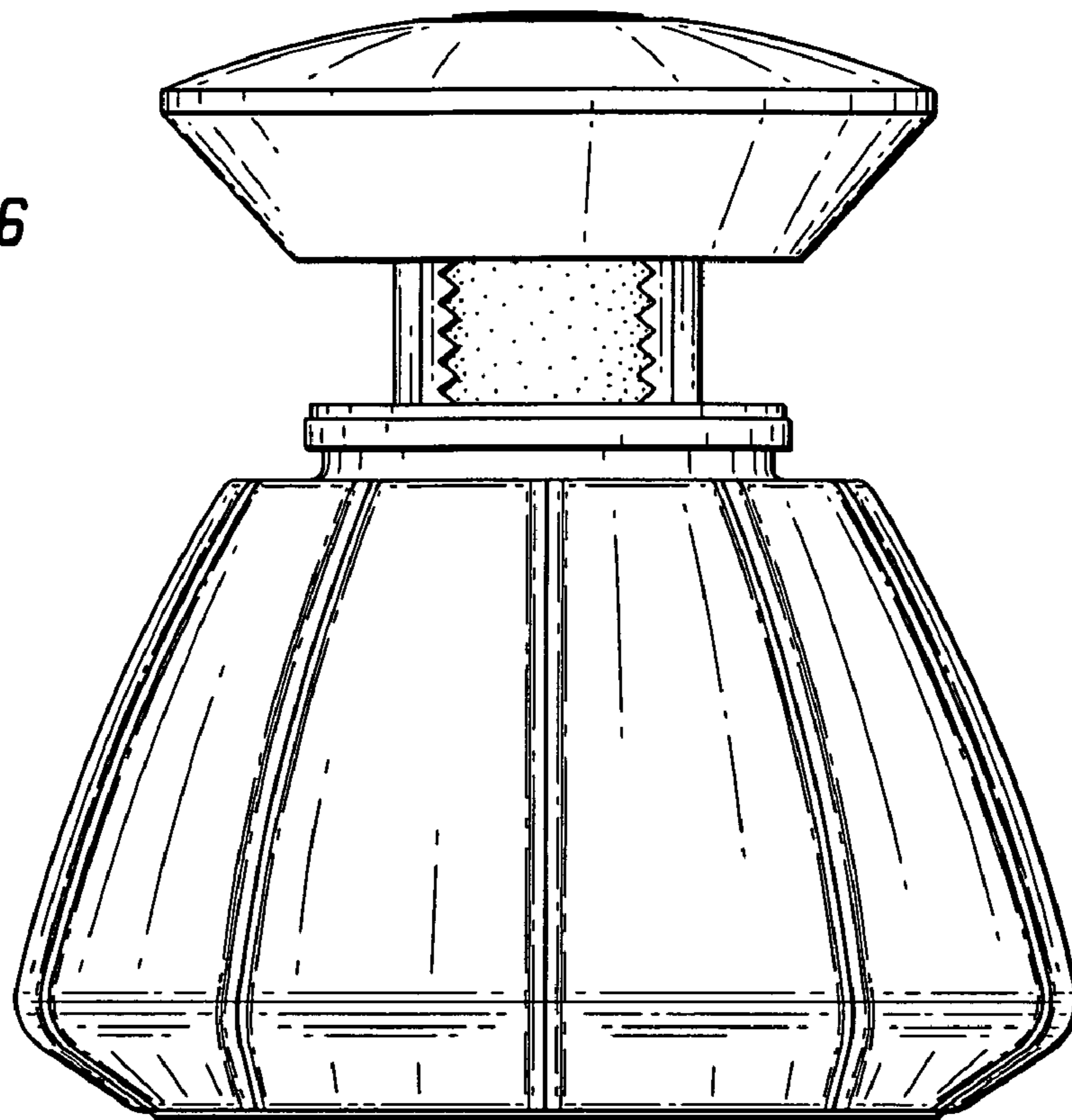

FIG. 7

