



US00D562878S

(12) **United States Design Patent**  
**Laukat et al.**

(10) **Patent No.:** **US D562,878 S**  
(45) **Date of Patent:** **\*\* Feb. 26, 2008**

(54) **TRUMPET COMPONENT**

(75) Inventors: **Sheryl Laukat**, Sandy, UT (US); **Tevis Laukat**, Sandy, UT (US)

(73) Assignee: **Cannonball Musical Instruments**, Sandy, UT (US)

(\*\*) Term: **14 Years**

(21) Appl. No.: **29/219,452**

(22) Filed: **Dec. 16, 2004**

(51) **LOC (8) Cl.** ..... **17-02**

(52) **U.S. Cl.** ..... **D17/10**

(58) **Field of Classification Search** ..... D17/10,  
D17/11, 13; D21/411; 84/380 R, 385 R,  
84/388, 735, 741-743

See application file for complete search history.

(56) **References Cited**

U.S. PATENT DOCUMENTS

350,493	A *	10/1886	Jungerman	.....	D21/411
D43,205	S *	10/1912	Reynolds	.....	D17/11
1,632,008	A	6/1927	Lemm		
1,716,929	A	6/1929	Packan		
1,828,389	A	10/1931	Calvani		
1,873,184	A	8/1932	Calvani		
2,033,772	A	3/1936	Loomis		
2,055,382	A	9/1936	Loomis		
2,151,337	A	3/1939	Selmer		
2,555,980	A	6/1951	Loney		
2,846,917	A	8/1958	Lefevre-Selmer		
3,657,464	A	4/1972	Pascucci		
3,865,005	A	2/1975	Carree		
4,148,242	A	4/1979	Woehr et al.		
4,250,791	A	2/1981	Tairadate		
4,453,445	A	6/1984	Todd		
D321,730	S *	11/1991	McElhaney	.....	D21/411
5,900,562	A	5/1999	Smeding		

5,990,398	A	11/1999	Nonaka		
6,265,649	B1	7/2001	Smeding		
6,815,599	B2 *	11/2004	Asahi	.....	84/485 R
D504,146	S *	4/2005	Suzuki	.....	D17/11

OTHER PUBLICATIONS

“The Collection of H.N. White Instruments” H.N. White. <<http://www.hnwhite.com/Instruments.htm>>, undated.

“King Liberty Trumpet No. 1050: Picture 3 With Mini” H.N. White. <<http://www.hnwhite.com/King/My%20Trumpts/Liberty%20Trumpet%20With%20Mini%20Trumpet%20Gold.jpg>>, undated.

(Continued)

*Primary Examiner*—Adir Aronovich

(74) *Attorney, Agent, or Firm*—Advantia Law Group; Michael W. Starkweather; Jason P. Webb

(57) **CLAIM**

The ornamental design for the trumpet component, as shown and described.

**DESCRIPTION**

FIG. 1 is a bottom perspective view of a trumpet component showing our design;

FIG. 2 is a reduced front view of the trumpet component attached to a return side of a lead pipe of a trumpet;

FIG. 3 is a front view of the trumpet component;

FIG. 4 is a top plan view of the trumpet component;

FIG. 5 is a bottom plan view of the trumpet component;

FIG. 6 is a right side view of the trumpet component; and,

FIG. 7 is a left side view of the trumpet component.

The broken line showing of an outline and contour of a trumpet is included for the illustration only and forms no part of the claimed design.

**1 Claim, 5 Drawing Sheets**

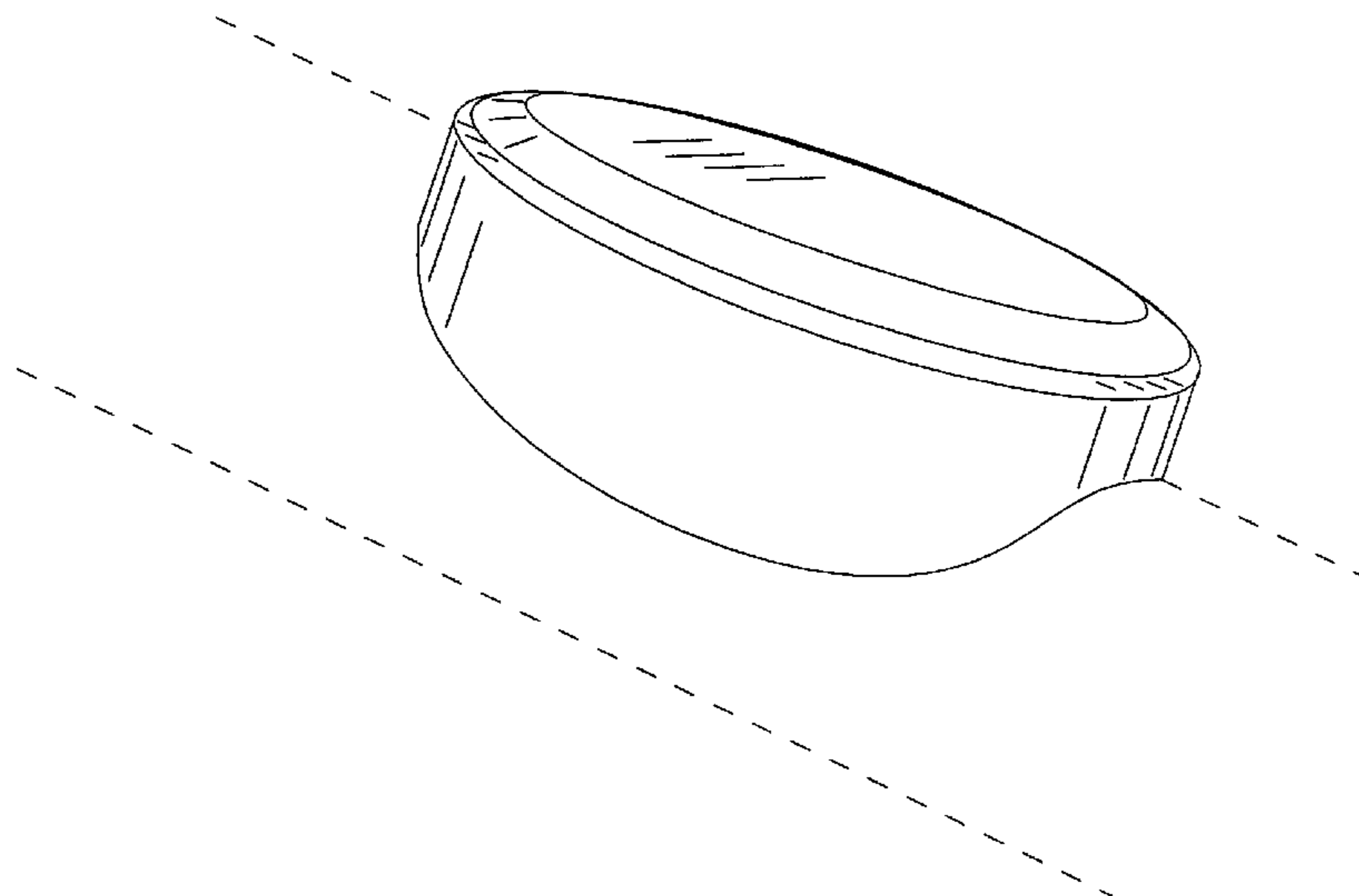

## OTHER PUBLICATIONS

“Trumpets and Cornets from Dave Ballard, Isle of Wight.” David Ballard. <<http://www.daveballard.co.uk/trumpets.htm>>, undated.

“Trumpet.” *Azerimusic*. <<http://www.azerimusic.net/old/lazim/back/pic/trumpet.jpg>>, undated.

“Trumpet.” *Music at Virginia Tech*. <<http://www.music.vt.edu/musicdictionary/textt/images/trumpet.jpg>>, undated.

“Trumpet.” CentralSource.com. <<http://www.centalsource.com/blender/intheworks/trumpet.jpg>>, undated.

“Dave’s Bach Trumpet Page.” *Electrotheremin.com*. <<http://www.electrotheremin.com/DS001.html>>, undated.

“ZeuS Bb Trumpet, Olympus, C Trupet, Guarnerius.” *Colorado Brass and Woodwinds*. <<http://www.co-bw.com/Trumpet%20Main%20CBAW.htm>>, undated.

“Trumpet.” *Resonans Musikk*. <<http://www.korpsinstrumenter.no/prislister/trumpet1.jpg>>, undated.

Brass Instruments—J. Mansfield Trumpets—Sheet Music Instruments Accessories. MusicCity.com. <<http://www.musiccity.com/brass-7.html>>, undated.

“Ferguson Music at Hornguys.com—Fine Musical Instruments.” Hornguys.com. <<http://www.hornguys.com/hornsinstock.htm>>, undated.

“Selmer Balanced Action Saxophone.” Don Mackrills Music Stop. 2004. <<http://www.donmack.com/Selmer/SelmerBalancedAction.htm>>.

“Welcome to Carl’s Professional Band Instrument Repair.” Carl’s Professional Band Instrument Repair. 2005. <<http://www.carlsproband.com/services/index.php>>.

“iStockphoto.com : saxophone2.” iStock International, Inc. 2005. <[http://www.istockphoto.com/file\\_closeup/objects/musical\\_instruments/80692\\_saxophone2.php?id=80692](http://www.istockphoto.com/file_closeup/objects/musical_instruments/80692_saxophone2.php?id=80692)>.

“Tech Topics: Interesting Questions . . .” CyberSax. <[http://www.cybersax.com/QA/Q&A\\_prosthetics.html](http://www.cybersax.com/QA/Q&A_prosthetics.html)>.

“Selmer MK VI Alto Sax Saxophone.” Zachary Music. 2002. <[http://www.zacharymusic.com/Zachary\\_Music/ZAS750Lpics.htm](http://www.zacharymusic.com/Zachary_Music/ZAS750Lpics.htm)>.

“ZeuS ZAS Alto Saxophone Intermediate.” Colorado Brass and Woodwinds. 2004. <<http://www.co-bw.com/ZAS%20650%20Alto%20Sax%20CBAW.htm>>.

“Alto Saxophone Index.” Pro Winds. 2005. <[http://www.prowinds.com/prowinds\\_web\\_2000/instruments/saxophones/index\\_alto.htm](http://www.prowinds.com/prowinds_web_2000/instruments/saxophones/index_alto.htm)>.

“Soprano Saxophone Index.” Pro Winds. 2005. <[http://www.prowinds.com/prowinds\\_web\\_2000/instruments/saxophones/index\\_soprano.htm](http://www.prowinds.com/prowinds_web_2000/instruments/saxophones/index_soprano.htm)>.

“Tenor Saxophone Index.” Pro Winds. 2005. <[http://www.prowinds.com/prowinds\\_web\\_2000/instruments/saxophones/index\\_tenor.htm](http://www.prowinds.com/prowinds_web_2000/instruments/saxophones/index_tenor.htm)>.

“Baritone Saxophone Index.” Pro Winds. 2005. <[http://www.prowinds.com/prowinds\\_web\\_2000/instruments/saxophones/index\\_baritone.htm](http://www.prowinds.com/prowinds_web_2000/instruments/saxophones/index_baritone.htm)>.

“Saxophones—Band and Musical Instruments.” Dominic’s Music—Band and Musical Instruments. <[http://www.dominicmusic.com/searchResult.php?group\\_id=4](http://www.dominicmusic.com/searchResult.php?group_id=4)>.

“Dave Guardala Saxophones.” Sax.Co.UK. 2005. <<http://www.saxophones.co.uk/index2.html>>.

“Conn.” A Brief Outline of the Origins of Orchestral Saxophones in F & C. May 2005. <<http://web.onetel.com/~gowoodward/02conn.htm>>.

“Yanagisawa Saxophone Necks (Bocals) from Eltham Woodwind and Brass.” Eltham Woodwind and Brass. <<http://www.elthamwoodwind.com.au/yanagisawa/bocal.html>>.

“Saxophone Necks by Peter Ponzol.” Peter Ponzol: Handcrafted Saxophone Products. <[http://www.peterponzol.com/neck\\_info/neck\\_information.htm](http://www.peterponzol.com/neck_info/neck_information.htm)>.

“PM Woodwind Repair: Saxophone Repair, Used Saxophones, Selmer, Mark VI, Paul Masli . . .” PM Woodwind. <<http://www.pmwoodwind.com/instruments.cfm?categoryid=61>>.

“Selmer (Paris) Serie III Polished Brass, Matte lacquered Alto saxophone: Neck from Top.” SaxForte. <[http://www.saxforte.com/saxophones/Eb\\_Alto/Eb\\_Alto\\_Selmer\\_Paris\\_/Serie\\_III\\_Alto/Serie\\_III\\_Clear\\_Alto/s3a9.JPG](http://www.saxforte.com/saxophones/Eb_Alto/Eb_Alto_Selmer_Paris_/Serie_III_Alto/Serie_III_Clear_Alto/s3a9.JPG)>.

“The Gloger Crook.” Stephen Howard Woodwind Instrument Repairs & Restoration. <<http://www.shwoodwind.co.uk/Buying/Gloger.htm>>.

“Unison Saxophone Necks.” Hollywoodwinds. <<http://www.unisonsaxophone.com/necks.html>>.

“Home / Musikinstrumente / Orchesterinstrumente / Holzblasinstrumente / Saxophone / G1.” Yamaha Deutschland. <[http://www.yamaha\\_europe.com/yamaha\\_europe/germany/10\\_musical\\_instruments/20\\_orchestra/10\\_woodwind/60\\_saxophones/50\\_saxophones\\_necks/G1/index.html/G](http://www.yamaha_europe.com/yamaha_europe/germany/10_musical_instruments/20_orchestra/10_woodwind/60_saxophones/50_saxophones_necks/G1/index.html/G)>.

“Zephyr and Zephyr Special.” Zephyr and Zephyr Special Models. <<http://www.saxpics.com/king/zephyr.htm>>.

\* cited by examiner

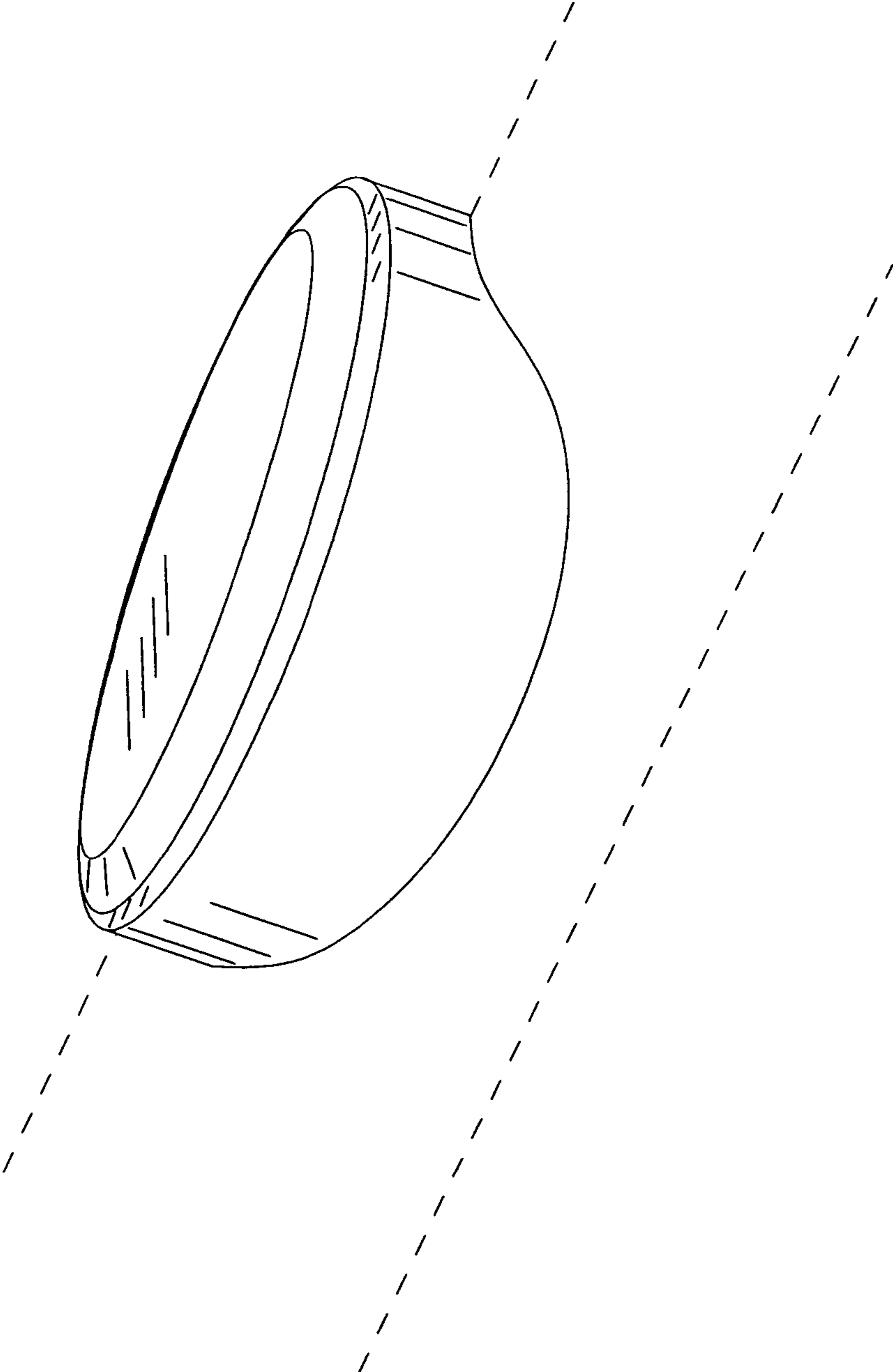

FIG. 1

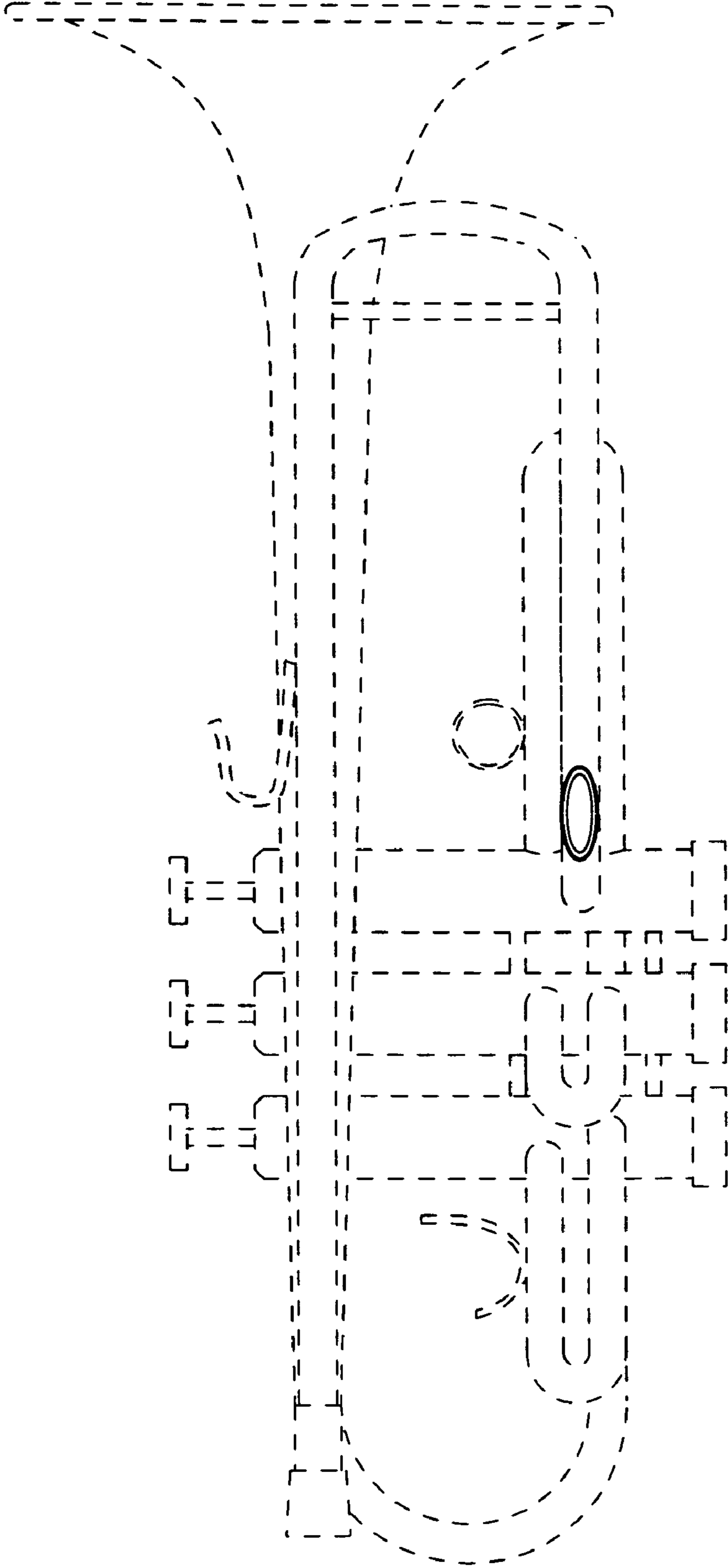
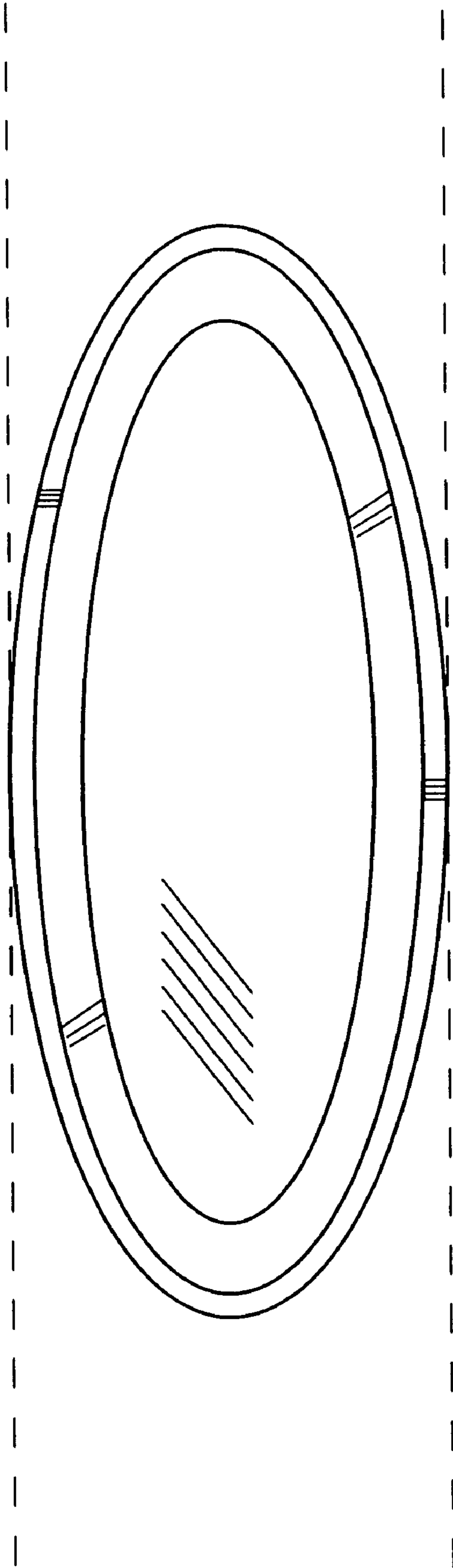
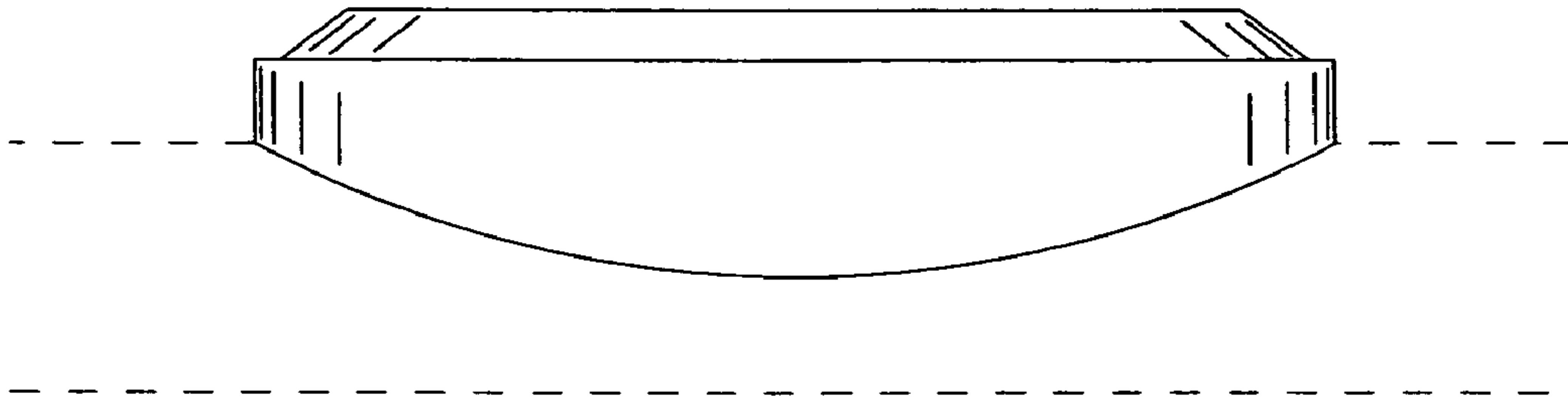

FIG. 2



**FIG. 3**



**FIG. 4**

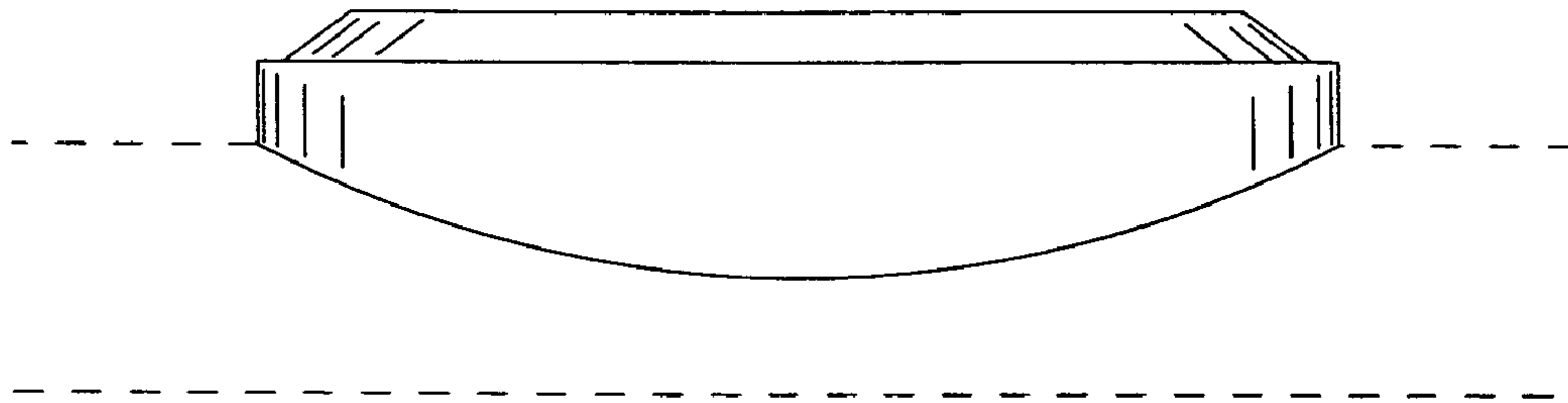

**FIG. 5**

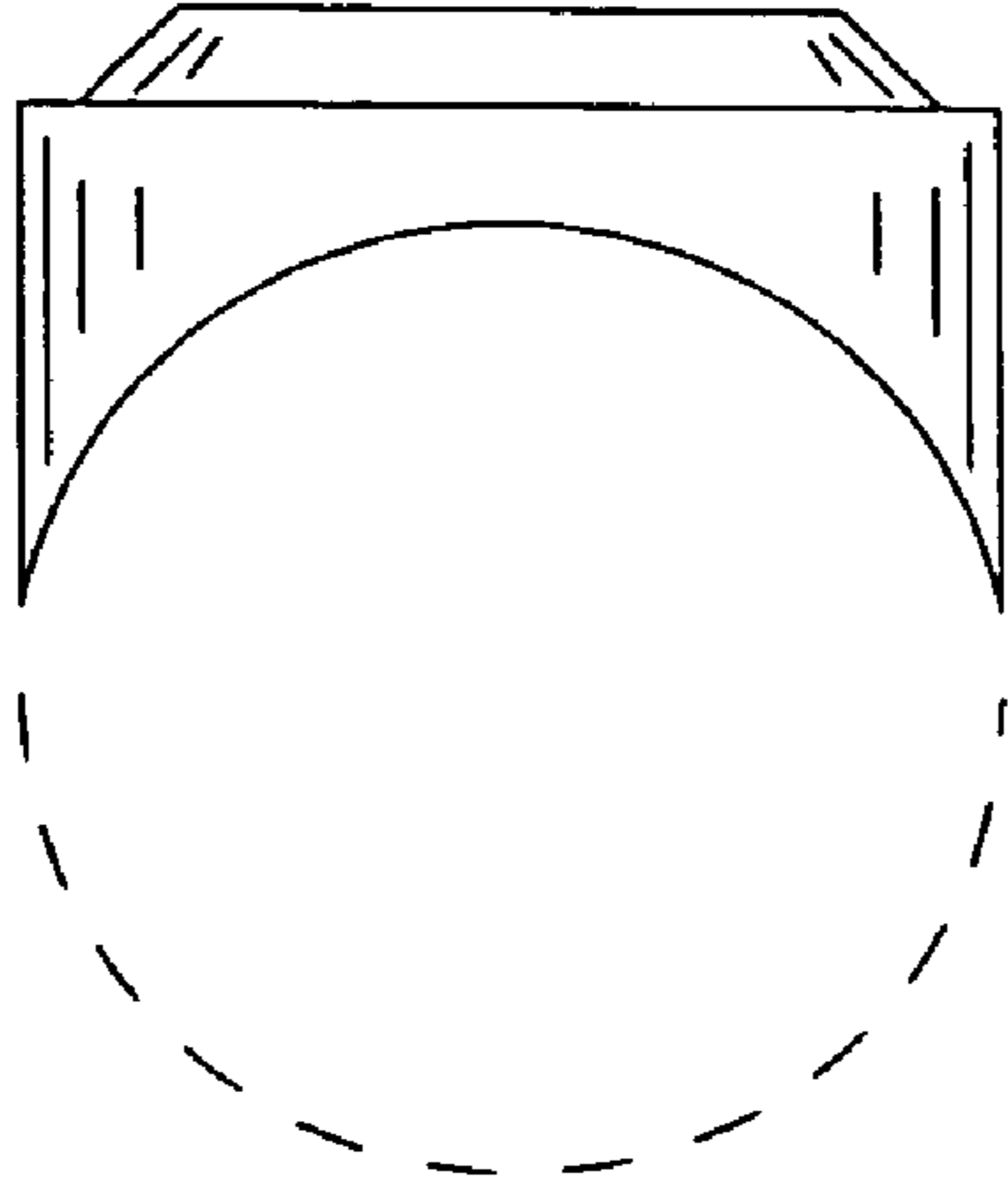

FIG. 6

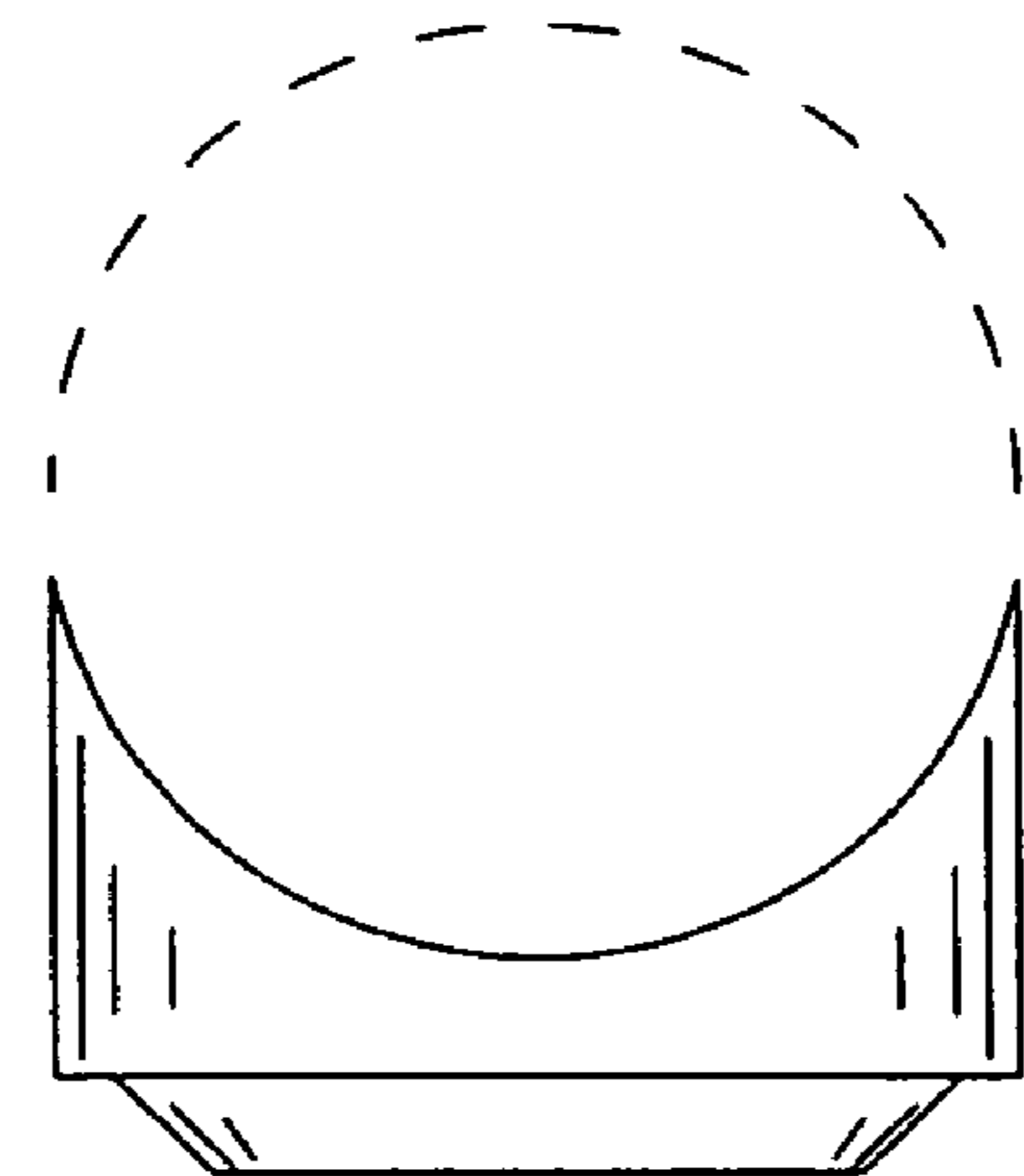

FIG. 7