



US00D562804S

(12) **United States Design Patent**  
**Fujiwara et al.**

(10) **Patent No.:** **US D562,804 S**

(45) **Date of Patent:** **\*\* Feb. 26, 2008**

(54) **SPEAKER**

(75) Inventors: **Satoru Fujiwara**, Yao (JP); **Masahide Suzuki**, Yao (JP); **Yuka Nagata**, Yao (JP)

(73) Assignee: **Hosiden Corporation**, Osaka (JP)

(\*\*) Term: **14 Years**

(21) Appl. No.: **29/275,215**

(22) Filed: **Dec. 18, 2006**

(30) **Foreign Application Priority Data**

Jul. 28, 2006 (JP) ..... 2006-019933

(51) **LOC (8) Cl.** ..... **14-01**

(52) **U.S. Cl.** ..... **D14/214**

(58) **Field of Classification Search** ..... D14/204,  
D14/209–216, 172, 188; 181/143–144, 147–148,  
181/150, 157, 198–199, 151, 153; 381/300–302,  
381/306, 333, 345, 361–364, 386–388, 332,  
381/336

See application file for complete search history.

(56) **References Cited**

**U.S. PATENT DOCUMENTS**

D425,897 S \* 5/2000 Cho ..... D14/214  
D430,141 S \* 8/2000 Liu ..... D14/215

D472,887 S \* 4/2003 Right et al. .... D14/172  
D485,825 S \* 1/2004 Yoneda ..... D14/215  
D487,083 S \* 2/2004 Asahina et al. .... D14/216  
D533,163 S \* 12/2006 Takase et al. .... D14/215  
D534,161 S \* 12/2006 Shimokawatoko et al. D14/216

\* cited by examiner

*Primary Examiner*—Nanda Bondade

(74) *Attorney, Agent, or Firm*—Panitch Schwarze Belisario & Nadel LLP

(57) **CLAIM**

The ornamental design for a speaker, as shown and described.

**DESCRIPTION**

FIG. 1 is a front, right and top perspective view of a speaker showing our new design;

FIG. 2 is rear, left and top perspective view thereof;

FIG. 3 is a front elevational view thereof;

FIG. 4 is a rear elevational view thereof;

FIG. 5 is a left side elevational view thereof;

FIG. 6 is a right side elevational view thereof;

FIG. 7 is a top plan view thereof; and,

FIG. 8 is a bottom plan view thereof.

**1 Claim, 3 Drawing Sheets**

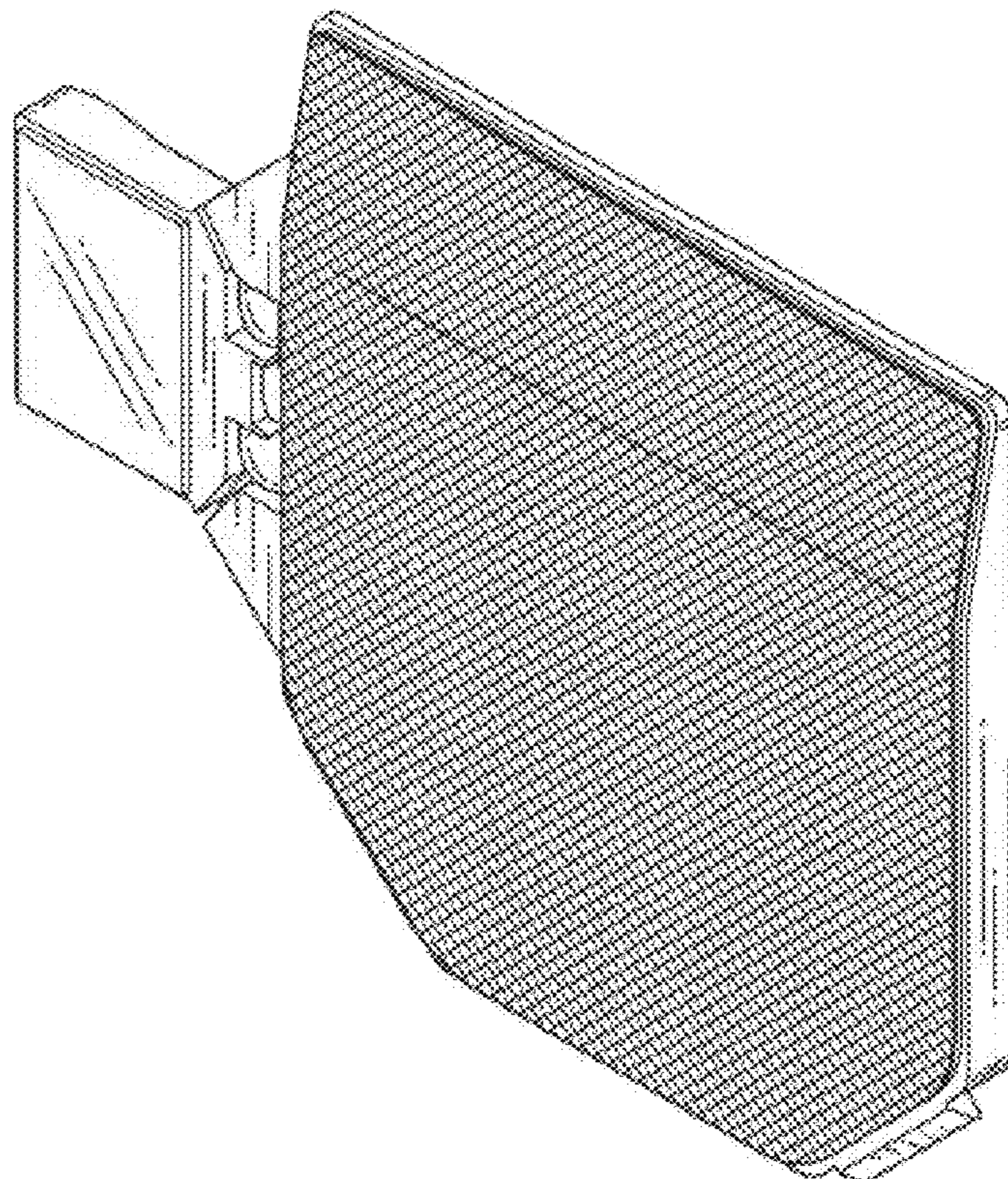

Fig. 1

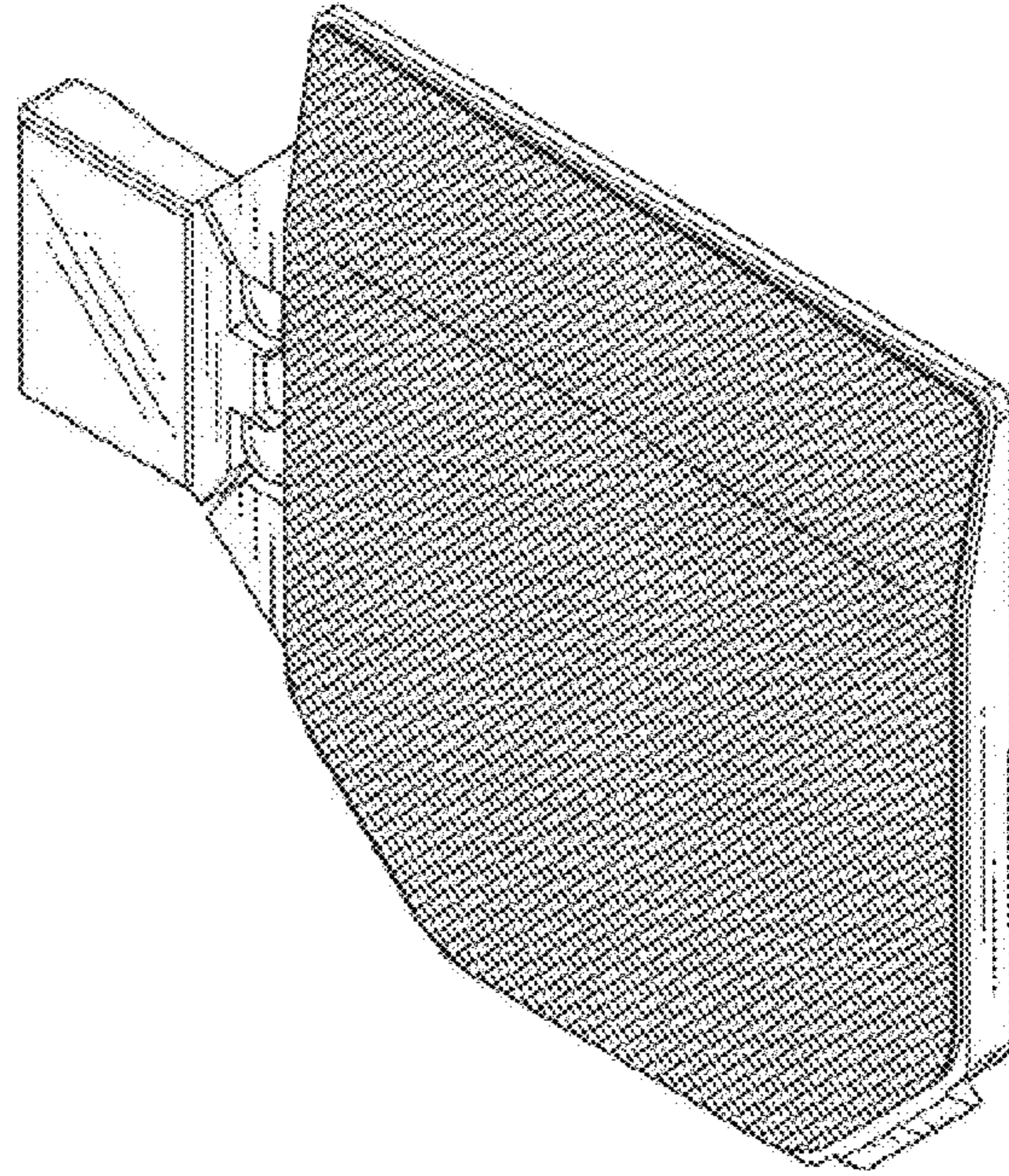

Fig. 2

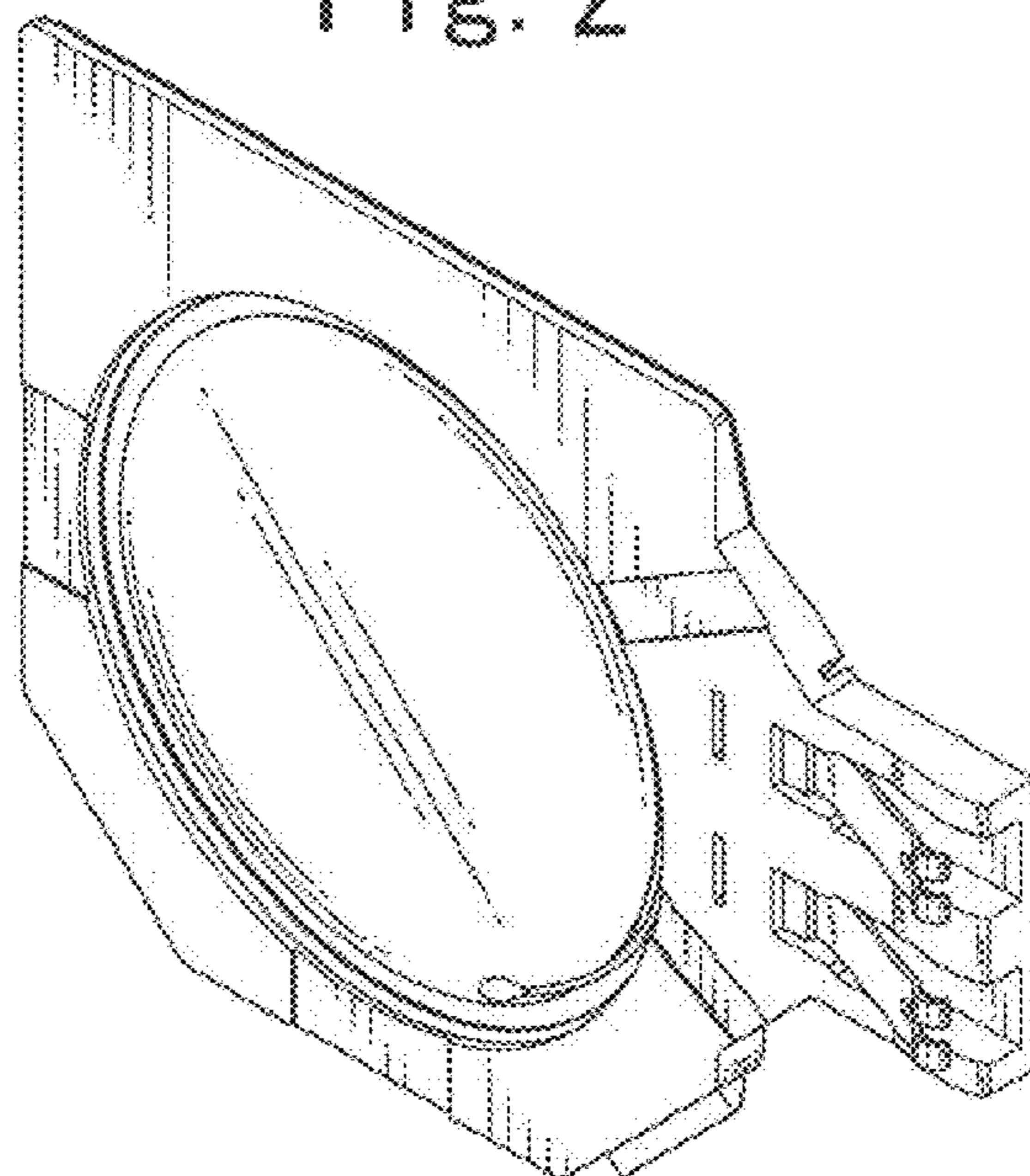

Fig. 3

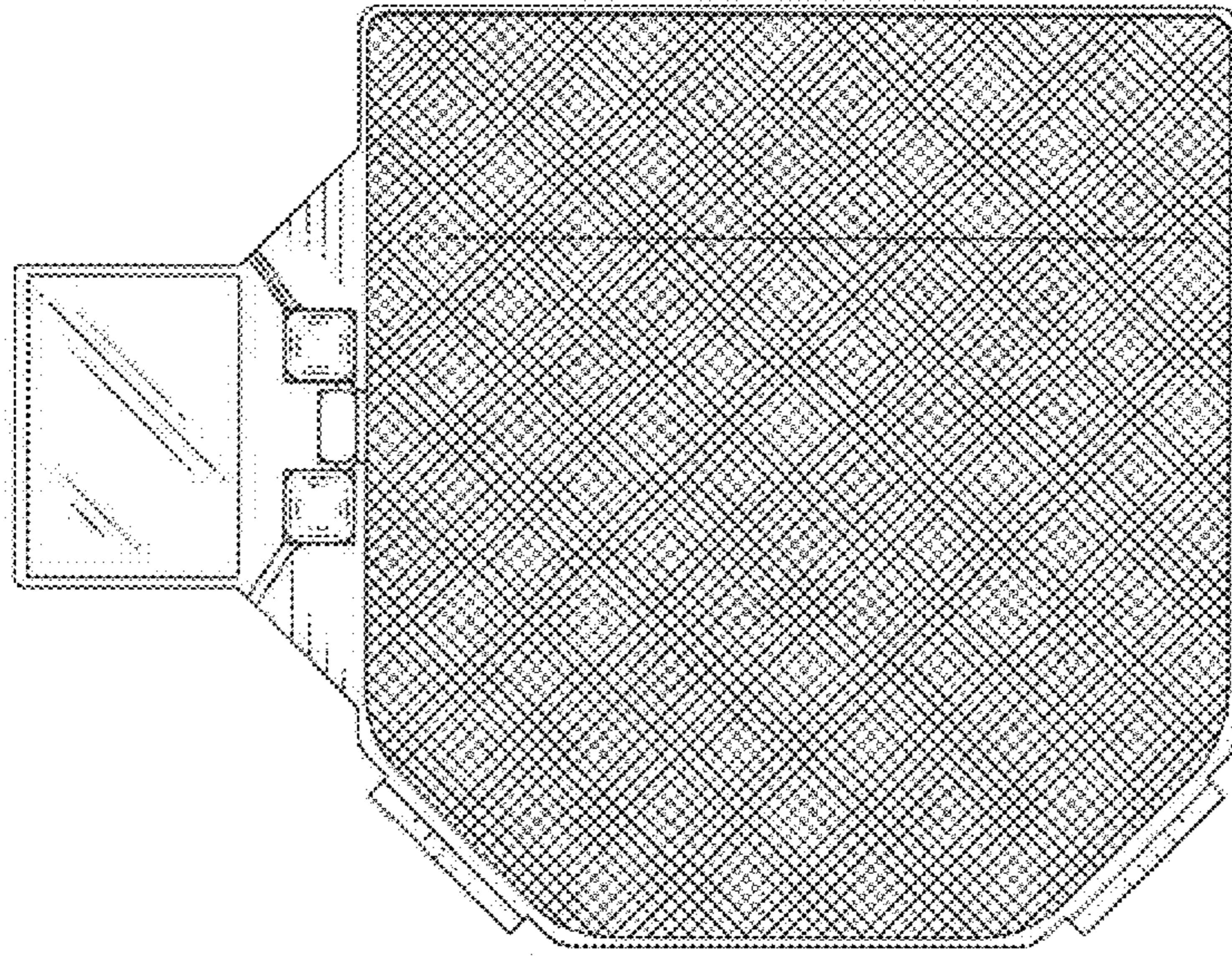

Fig. 4

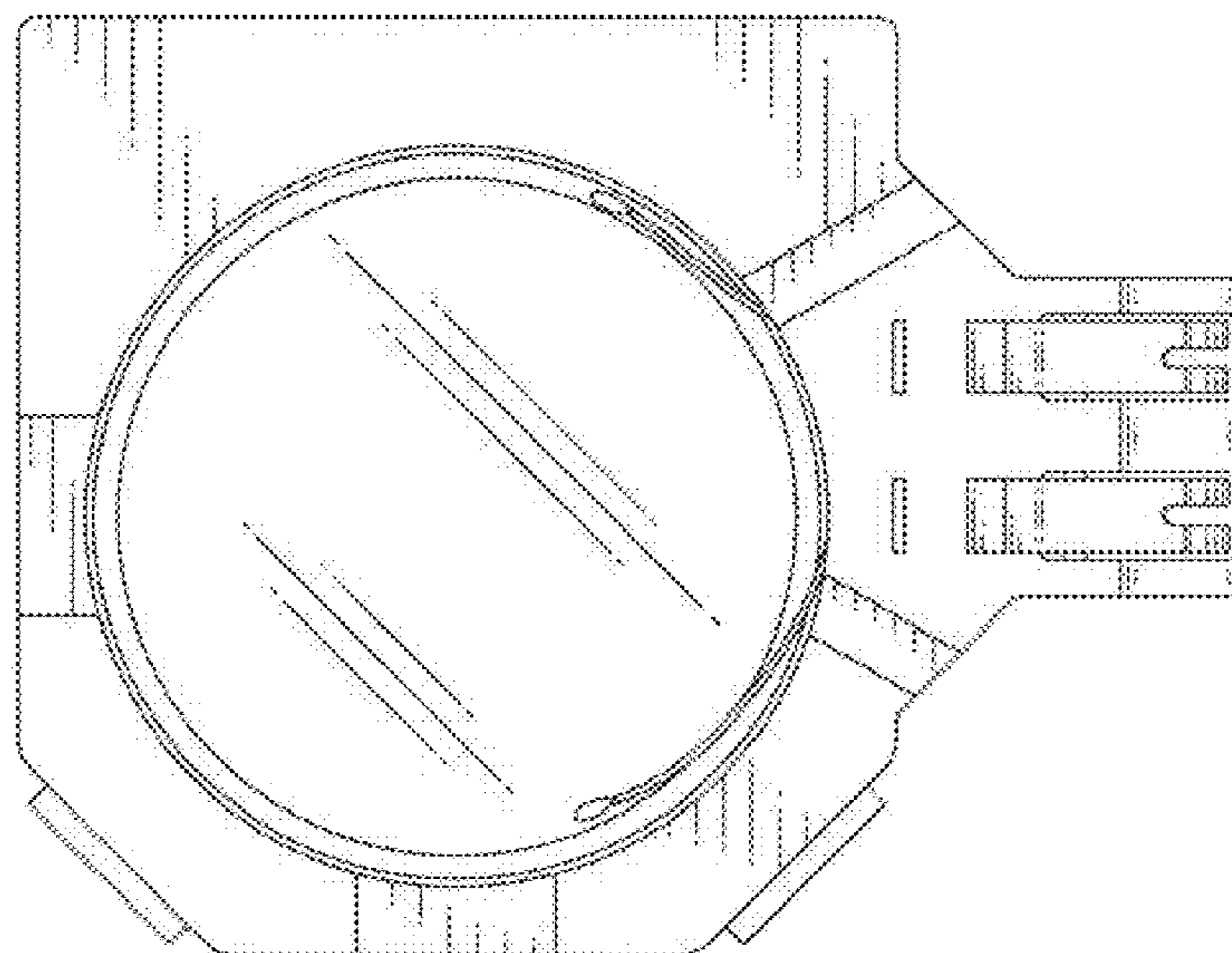

Fig. 5

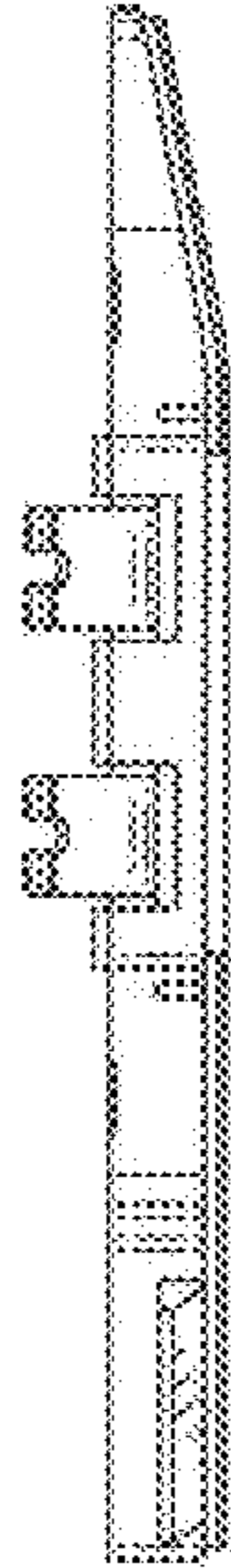

Fig. 6



Fig. 7

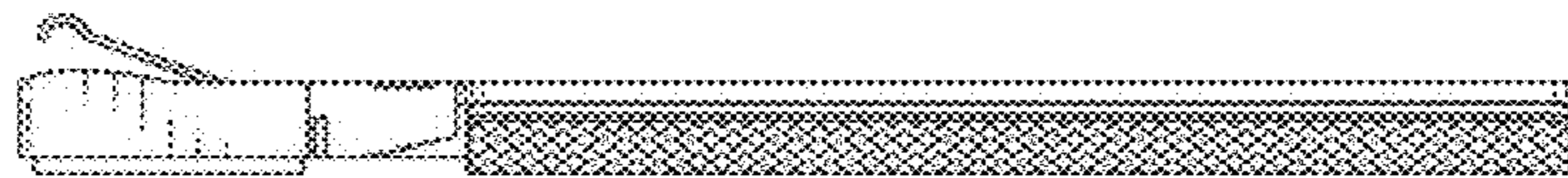

Fig. 8

