



US00D562747S

(12) **United States Design Patent**  
**Golden et al.**

(10) **Patent No.:** **US D562,747 S**  
(45) **Date of Patent:** **\*\* Feb. 26, 2008**

(54) **VEHICLE FENDER**

(75) Inventors: **Edward Golden**, Pinckney, MI (US);  
**George Bucher**, Dearborn, MI (US);  
**David Mahoney**, Orchard Lake, MI  
(US); **Michael Webb**, Harrison  
Township, MI (US)

(73) Assignee: **Ford Global Technologies, LLC**,  
Dearborn, MI (US)

(\*\*) Term: **14 Years**

(21) Appl. No.: **29/250,328**

(22) Filed: **Nov. 10, 2006**

(51) **LOC (8) Cl.** ..... **12-16**

(52) **U.S. Cl.** ..... **D12/184**

(58) **Field of Classification Search** ..... D12/173,  
D12/96, 97, 184; 180/69.2, 89.12, 89.13,  
180/89.67, 89.7; 296/184.1

See application file for complete search history.

(56) **References Cited**

**U.S. PATENT DOCUMENTS**

D489,656 S *	5/2004	Kneefel et al.	.....	D12/184
D493,393 S *	7/2004	Kneefel et al.	.....	D12/184
D514,993 S *	2/2006	Lee	.....	D12/184
D536,648 S *	2/2007	Fujimaki	.....	D12/184
D542,200 S *	5/2007	Levy	.....	D12/184

**OTHER PUBLICATIONS**

Winding Road for Drivers, Oct. 2006 <http://news.windingroad.com/auto-news/ford-still-says-this-car-doesnt-exist-2009-mercury-monticello-spied/>.

Ford Freestyle Limited, Chicago 2004 (14 views).

\* cited by examiner

*Primary Examiner*—Melody N. Brown

(74) *Attorney, Agent, or Firm*—Damian Porcari

(57) **CLAIM**

The ornamental design for a vehicle fender, as shown and described.

**DESCRIPTION**

FIG. 1 is a front elevational view of a vehicle fender as viewed from the left side of a vehicle showing our new design; the vehicle fender as viewed from the right side of a vehicle is a mirror image and is not shown.

FIG. 2 is a left side elevational view thereof;

FIG. 3 is a right side elevational view thereof;

FIG. 4 is a rear elevational view thereof;

FIG. 5 is a top plan view thereof;

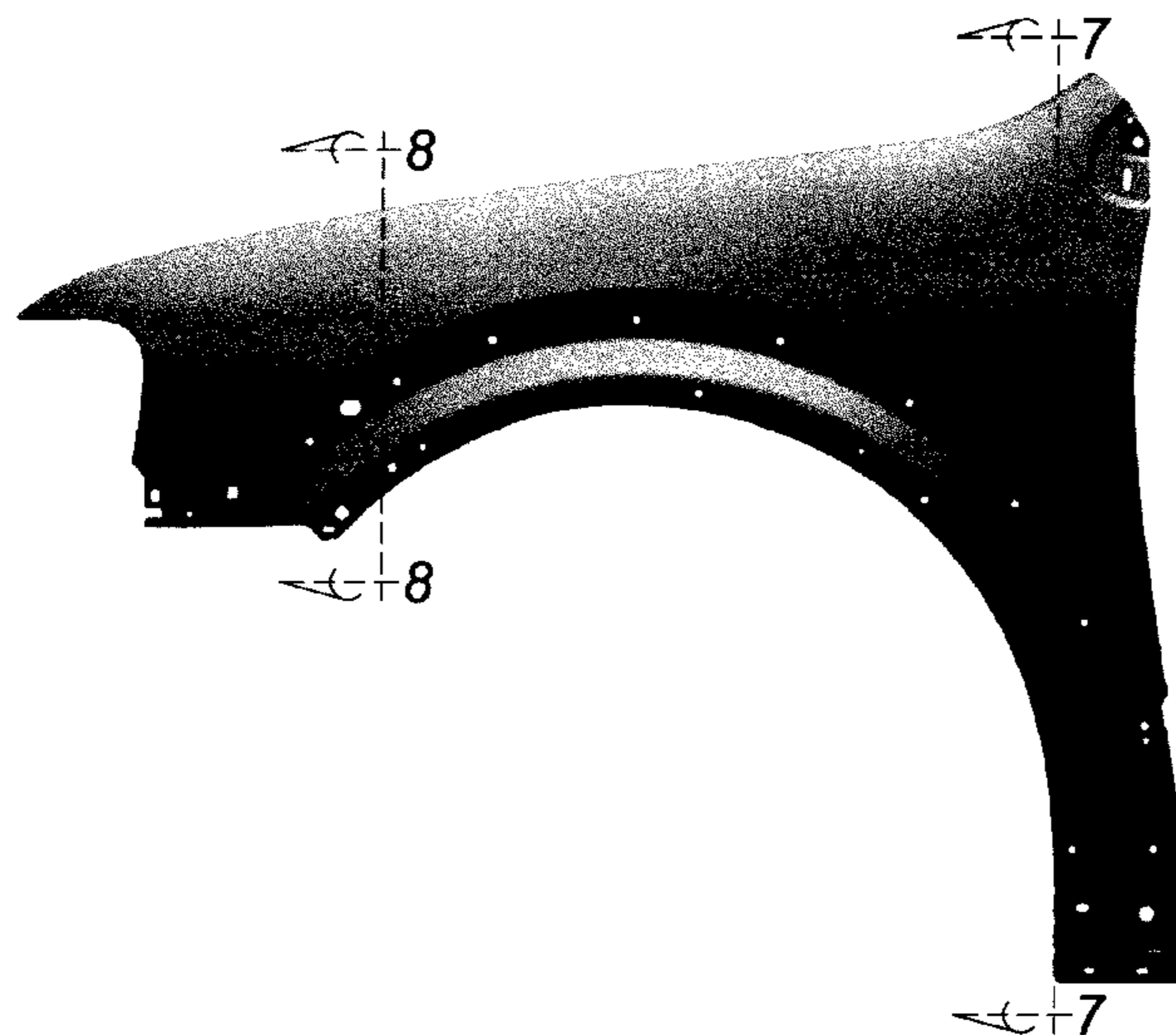
FIG. 6 is a bottom plan view thereof;

FIG. 7 is a cross sectional view taken along the line 7—7 in FIG. 1; and,

FIG. 8 is a cross sectional view taken along the line 8—8 in FIG. 1.

The vehicle fender is styled independently of adjacent vehicle panels. To the extent that any feature lines are illustrated, they are intended to illustrate the crest and valley of the feature and are not necessarily sharp bends in the part. Shading is used to illustrate the curvature of the part and not color. Areas shown in or sounded by broken lines are not claimed. The surface normally visible when the vehicle fender is attached to a vehicle is called the “Class A” surface is claimed. The surface not normally visible when the vehicle fender is attached to a vehicle is called the “Class B” surface and is not claimed. Any functional features of the vehicle fender are not claimed. Views are orthogonal projections unless otherwise noted. The various views are not necessarily to scale in order to better illustrate the design. The drawings were generated using Computer Aided Design tools. Highlights and shading were added to the drawings to better illustrate the three-dimensional features of the part.

**1 Claim, 8 Drawing Sheets**





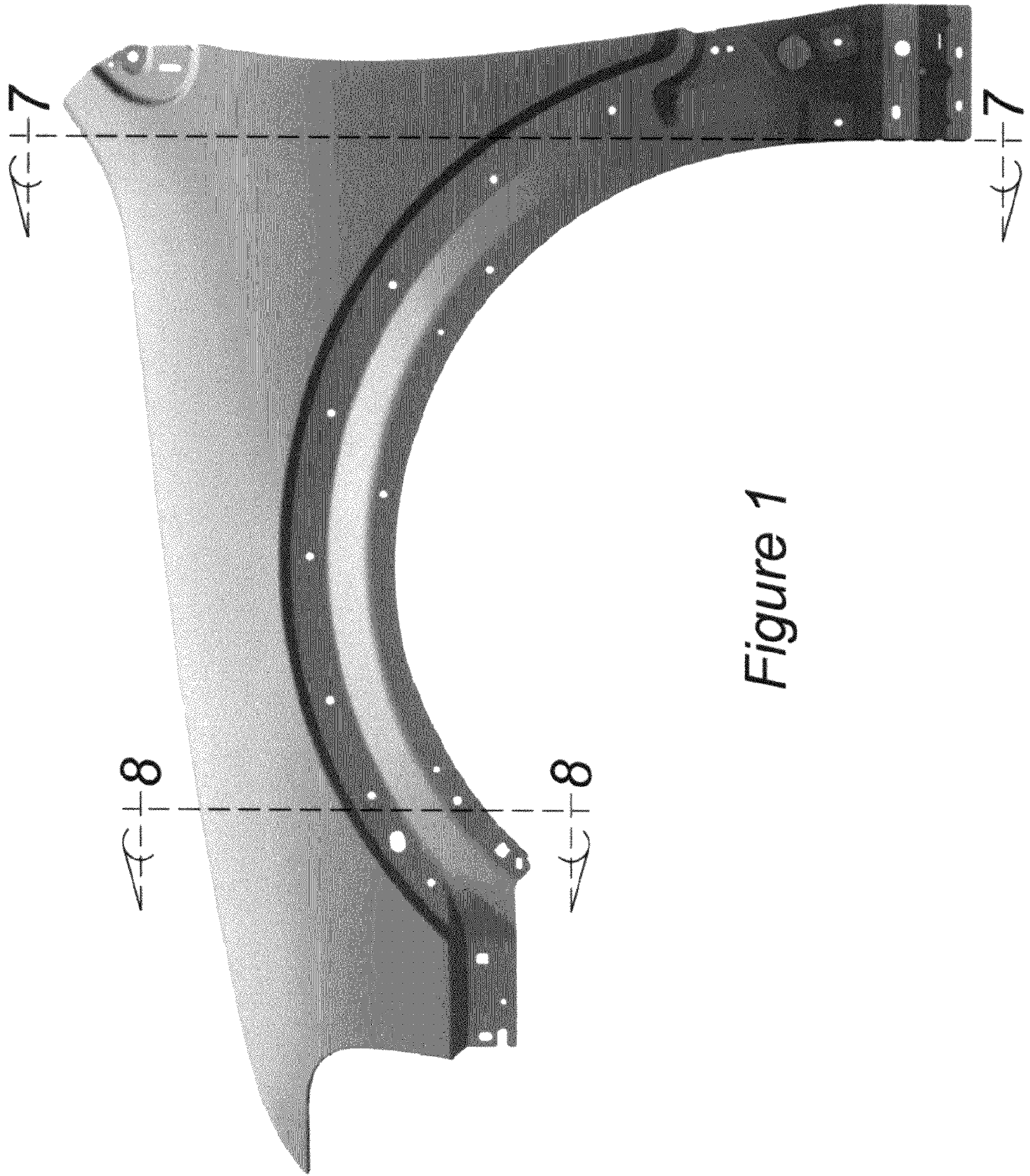
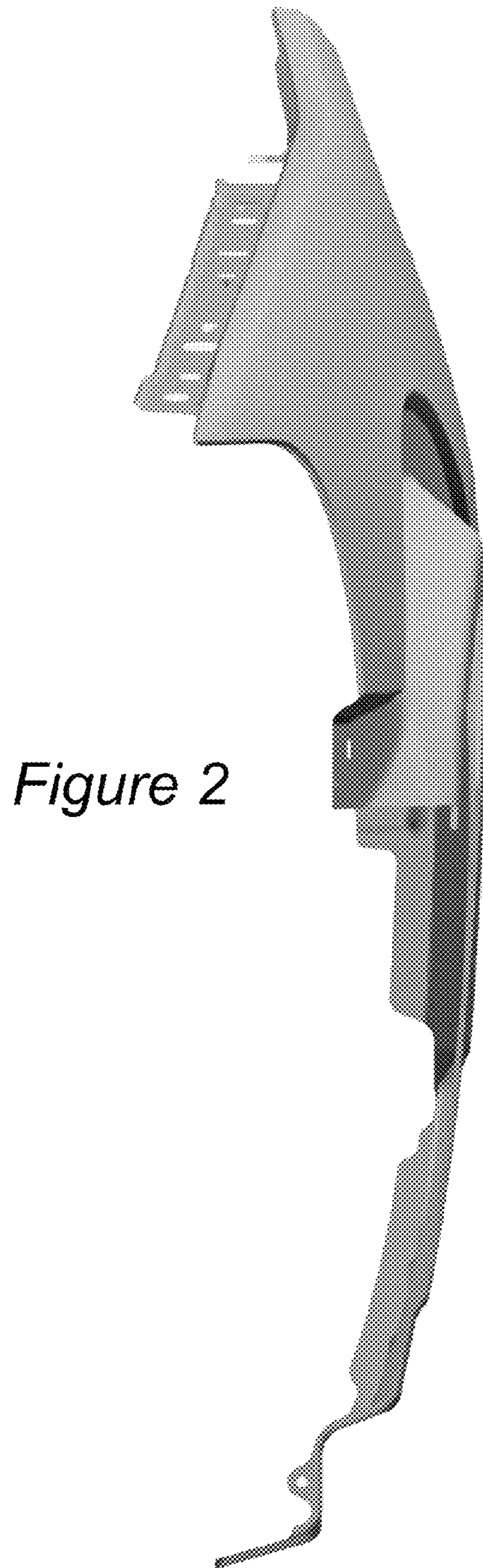
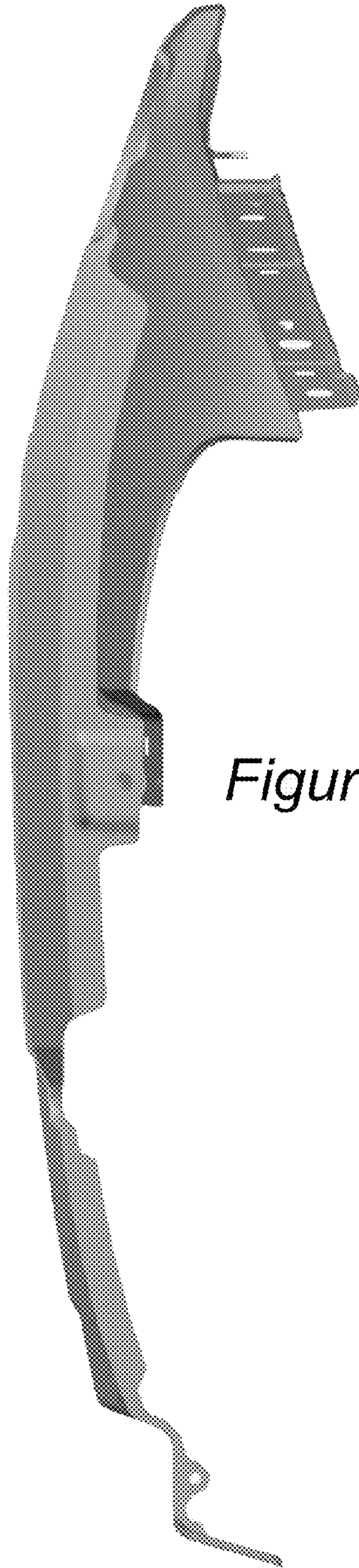


Figure 1







*Figure 3*



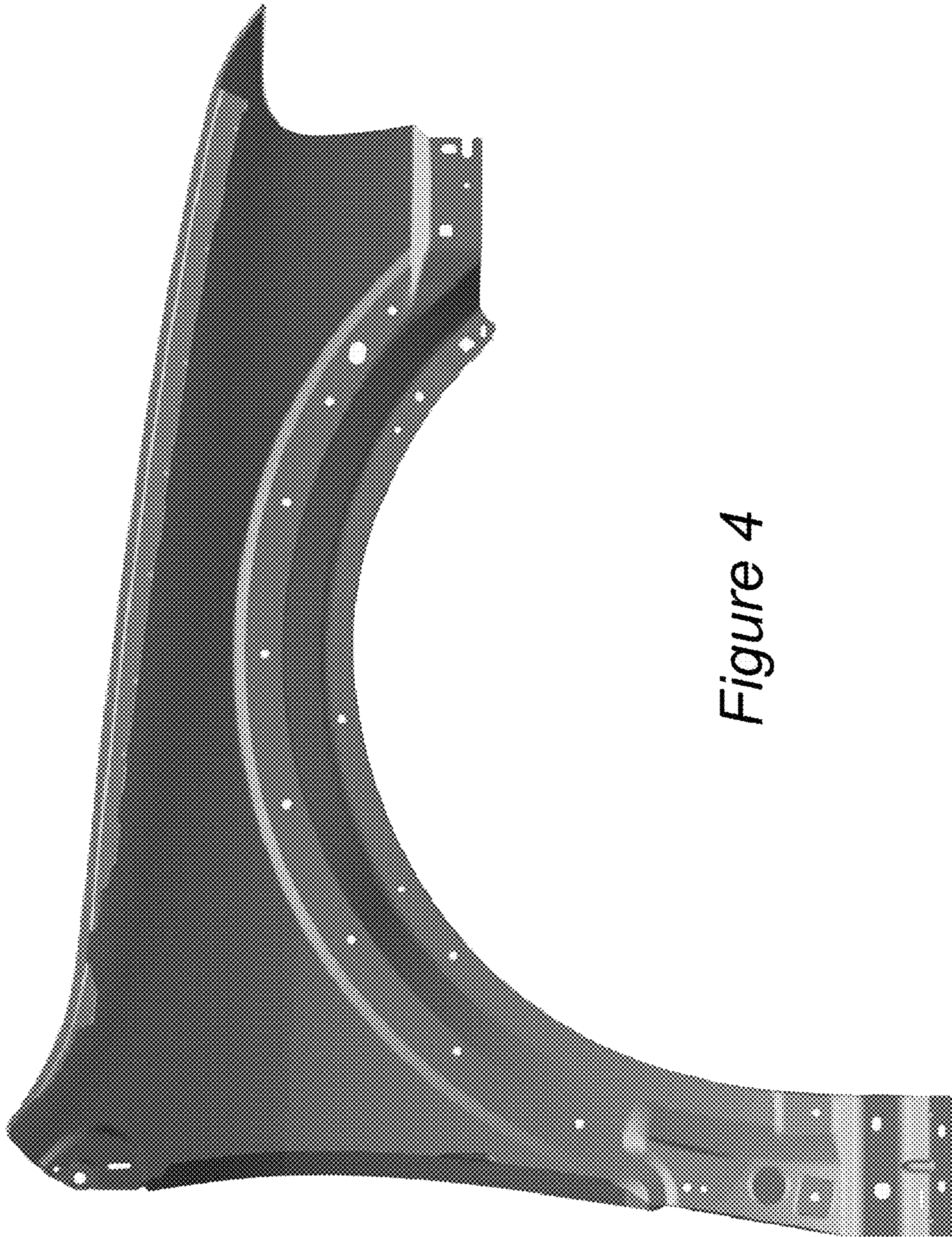
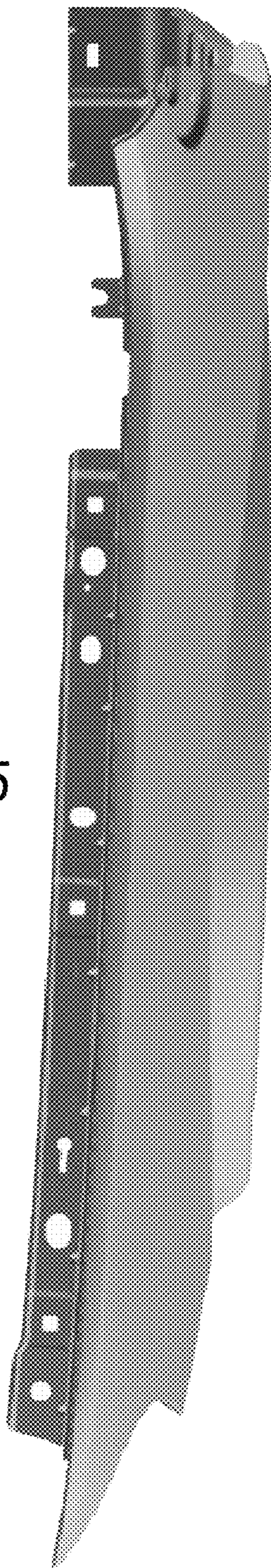


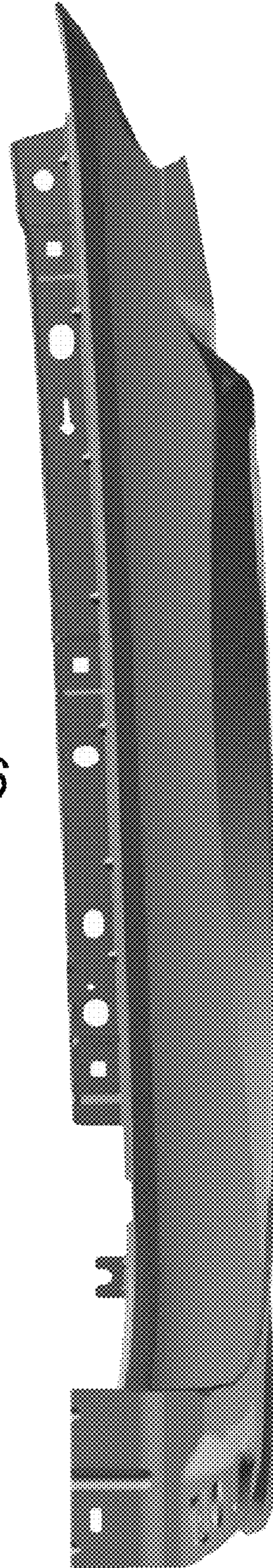
Figure 4



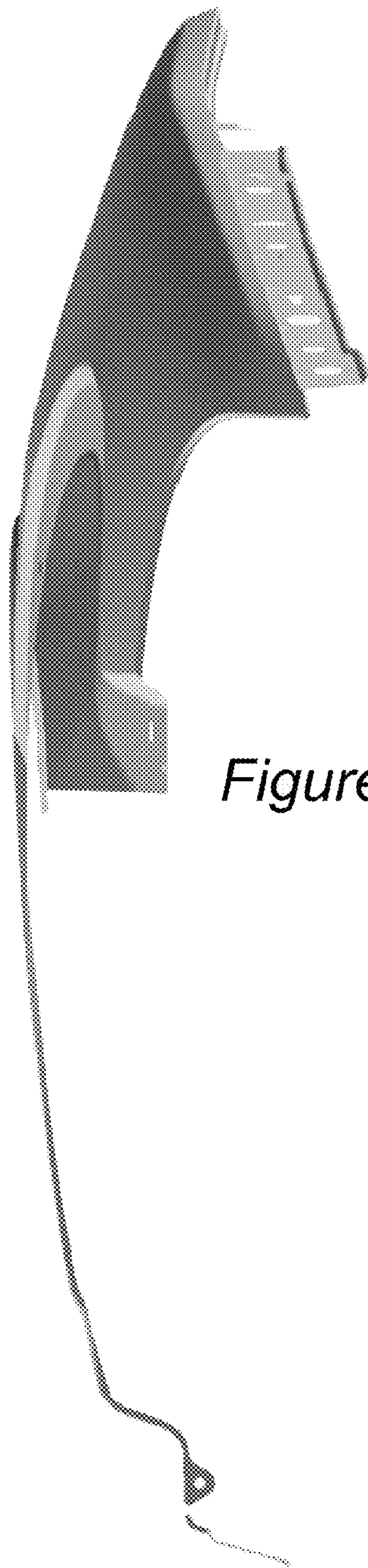


*Figure 5*

*Figure 6*

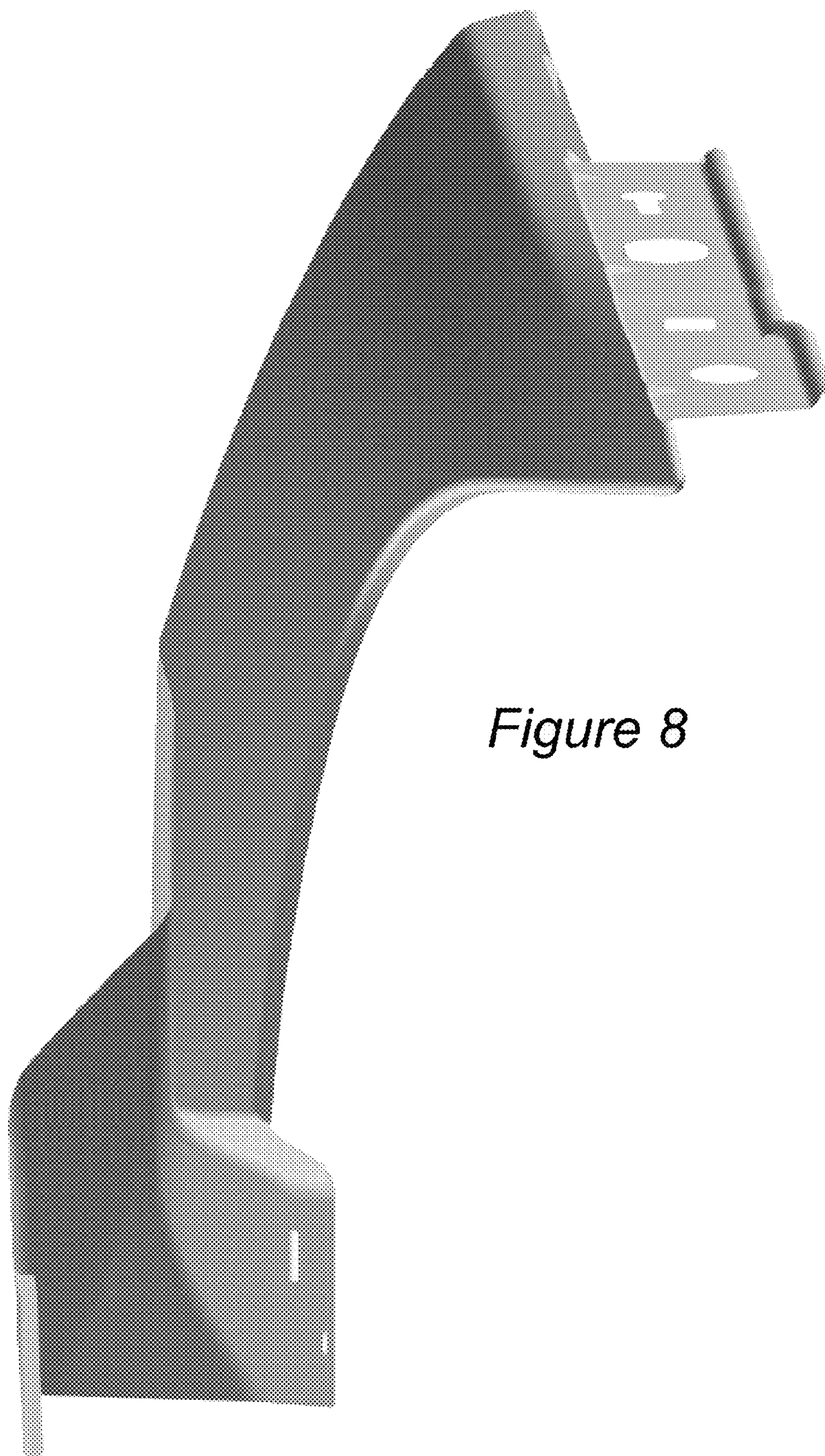






*Figure 7*





*Figure 8*