



US00D562525S

(12) **United States Design Patent**
Graf et al.

(10) **Patent No.:** **US D562,525 S**

(45) **Date of Patent:** **** Feb. 19, 2008**

(54) **LOW LEVEL ORDER PICKER LIFT TRUCK**

(75) Inventors: **Markus Graf**, Karlsfeld (DE); **Michael P. Gallagher**, Greenville, OH (US); **James V. Kraimer**, Celina, OH (US); **Philip D. Palermo**, Marietta, GA (US); **Robert J. Henshaw**, Newnan, GA (US)

(73) Assignee: **Crown Equipment Corporation**, New Bremen, OH (US)

(**) Term: **14 Years**

(21) Appl. No.: **29/250,144**

(22) Filed: **Nov. 3, 2006**

(51) **LOC (8) Cl.** **12-05**

(52) **U.S. Cl.** **D34/34**

(58) **Field of Classification Search** D34/28,
D34/34; 180/89.12, 29.13, 89.17; 187/222,
187/237

See application file for complete search history.

(56) **References Cited**

U.S. PATENT DOCUMENTS

2,354,178	A *	7/1944	Ulinski	187/235
3,265,158	A *	8/1966	Constable	187/232
D222,694	S *	12/1971	Goodacre	D34/34
D373,887	S *	9/1996	Soederberg	D34/34
D373,888	S *	9/1996	Soederberg	D34/34
D492,833	S *	7/2004	Henshaw et al.	D34/34
D539,503	S *	3/2007	Quinlan et al.	D34/35
D542,005	S *	5/2007	Weiner et al.	D34/34
2004/0099486	A1 *	5/2004	Gramatikov et al.	187/237
2005/0016782	A1 *	1/2005	Gallagher et al.	180/89.12

OTHER PUBLICATIONS

Crown specification brochure VFS-GPC-05-GB Sep. 2005, entitled Low Level Order Picker, Series GPC 2000, Germany.

Crown specification brochure No. SF14641 Mar. 2006, entitled Crown TR 3600 Series, Tow Tractor, U.S.A.

Crown specification brochure No. GPC2000 SL Broch Jun. 2005 30-M01353-006-00, entitled Crown 2000 Scissors Lift Series, Germany.

Crown specification brochure VFS-GPC-Tow-02-GB Jun. 2003, entitled Crown GPC-Tow Series, Tow Tractor, Germany.

* cited by examiner

Primary Examiner—Cynthia E Ramirez

(74) *Attorney, Agent, or Firm*—Stevens & Showalter LLP

(57) **CLAIM**

The ornamental design for a low level order picker lift truck, as shown.

DESCRIPTION

FIG. 1 is a perspective view of a low level order picker lift truck as seen from the top, back and left sides showing our new design;

FIG. 2 is a perspective view of a low level order picker lift truck as seen from the top, front and right sides;

FIG. 3 is a top plan view thereof;

FIG. 4 is a left side elevational view thereof, the right side elevational view being a mirror image;

FIG. 5 is a rear elevational view thereof; and,

FIG. 6 is a front elevational view thereof.

The broken line showings in the figures are for illustrative purposes only and form no part of the claimed design.

1 Claim, 4 Drawing Sheets

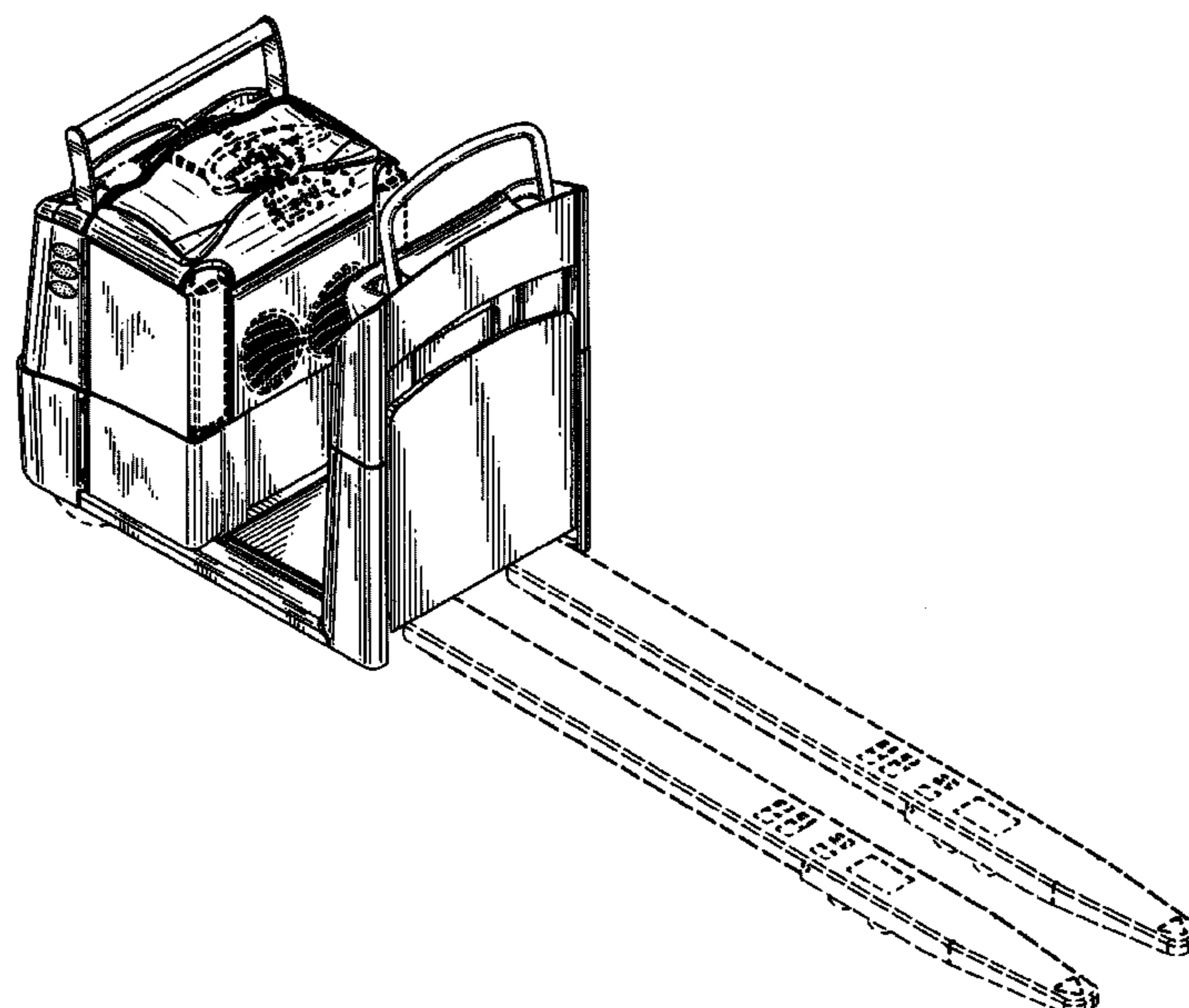
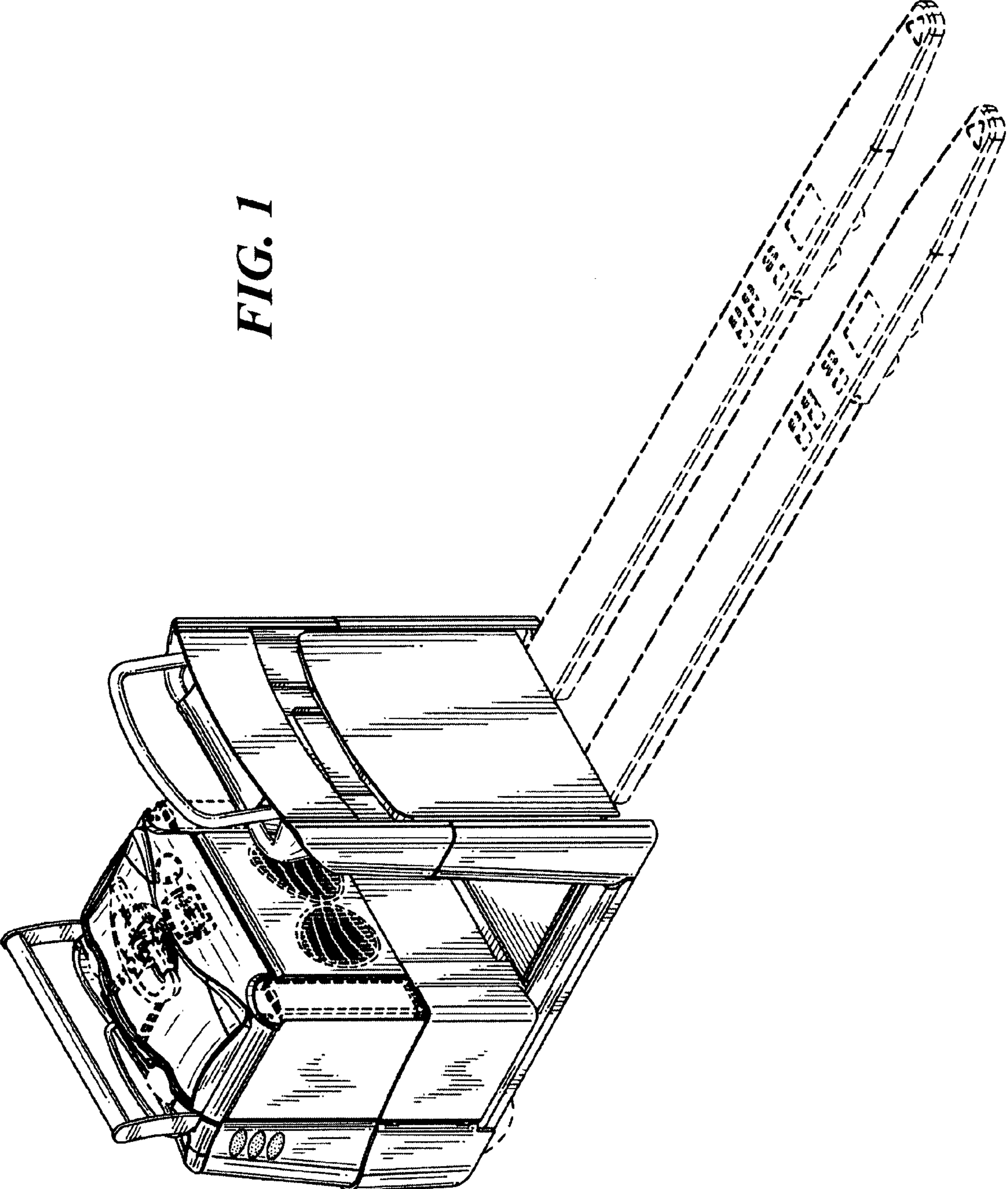

FIG. 1



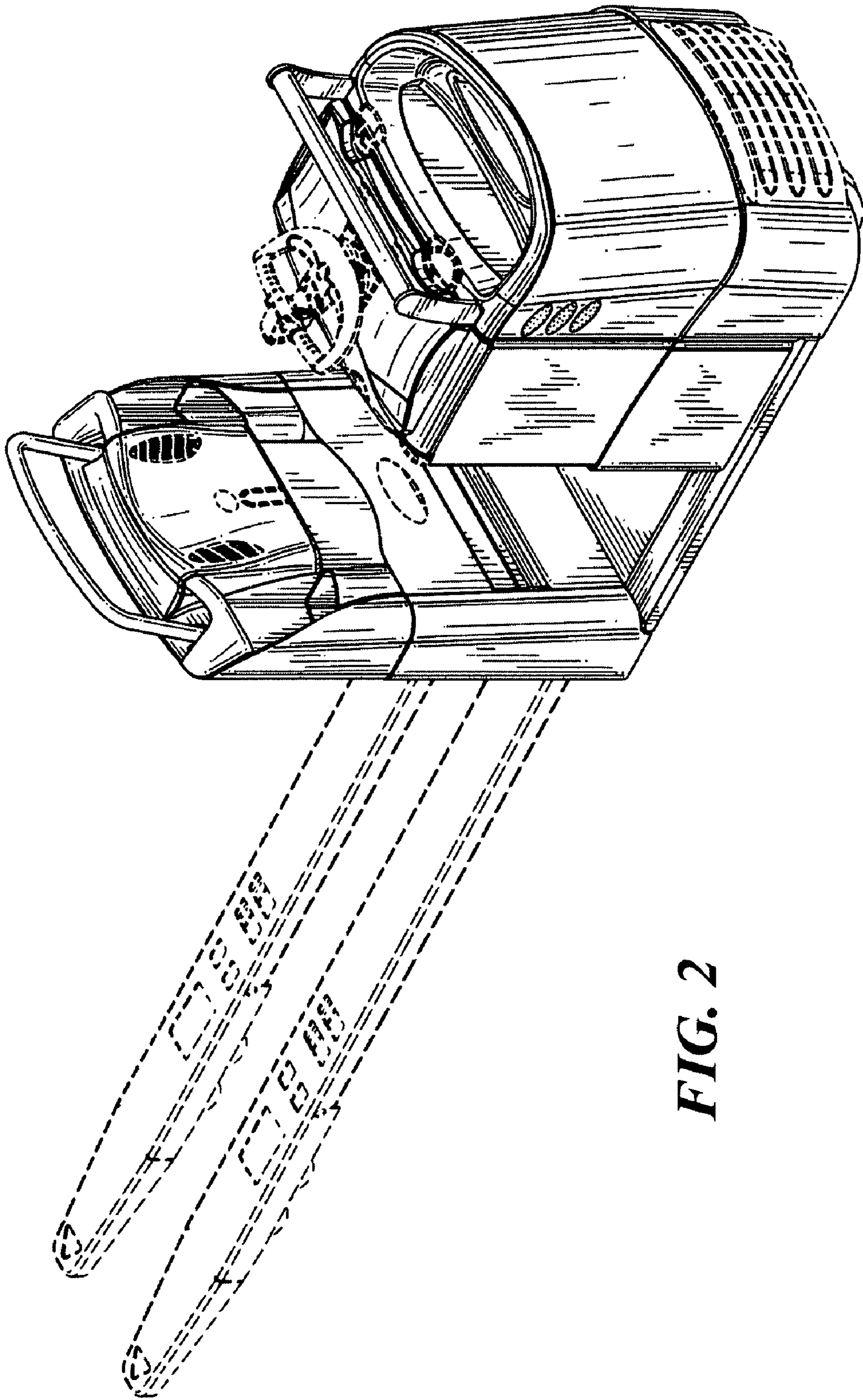

FIG. 2

FIG. 3

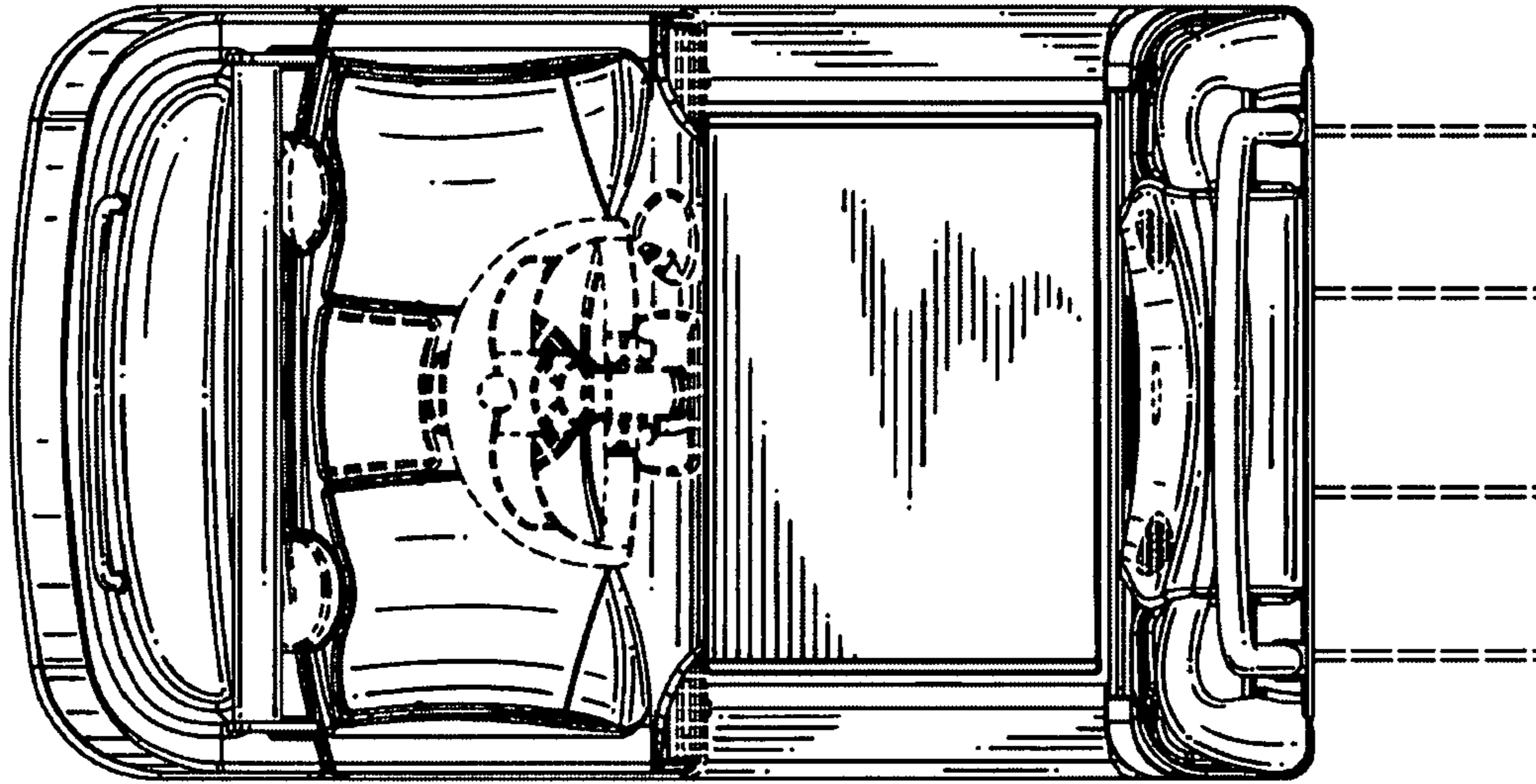

FIG. 4

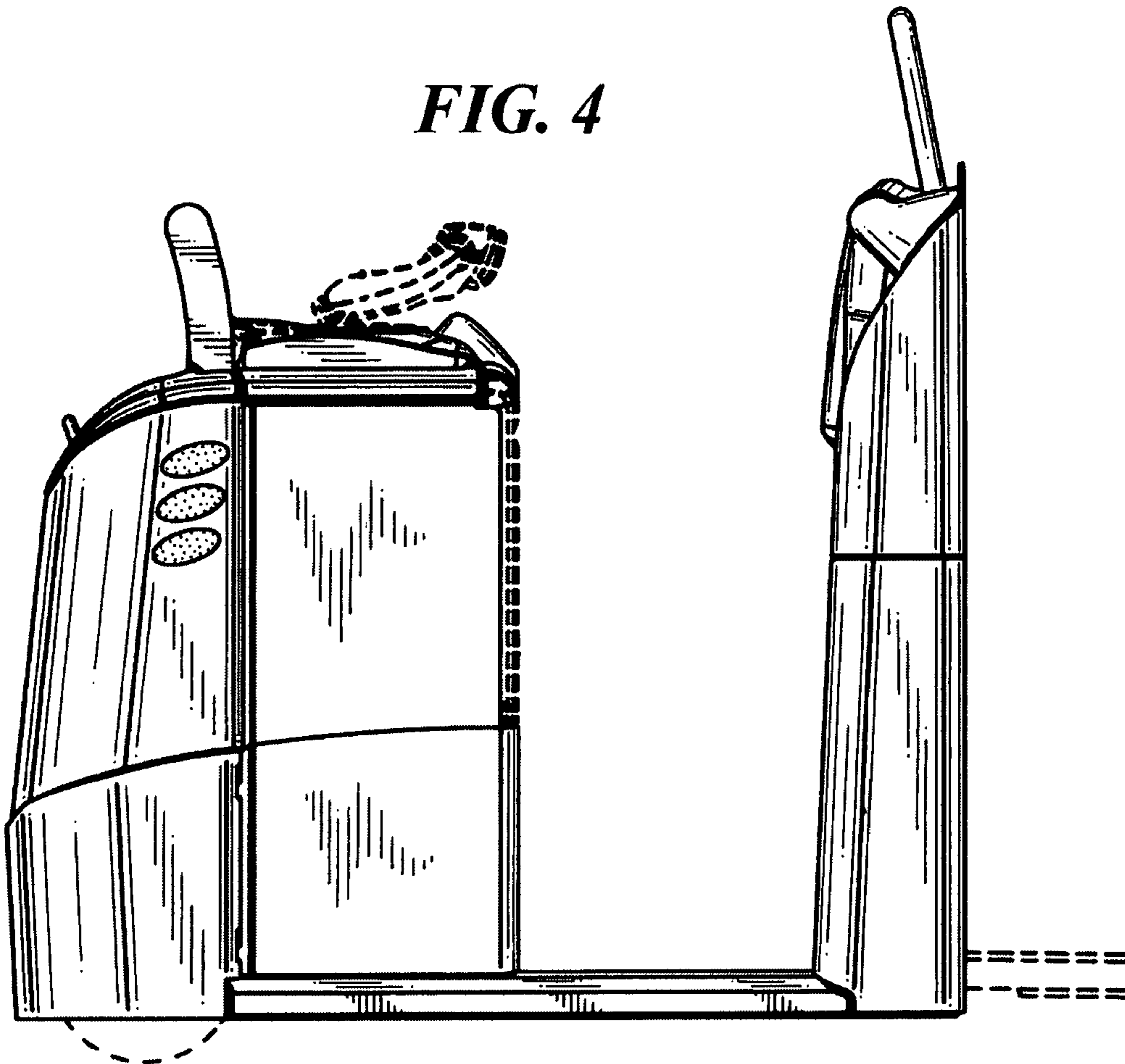

FIG. 5

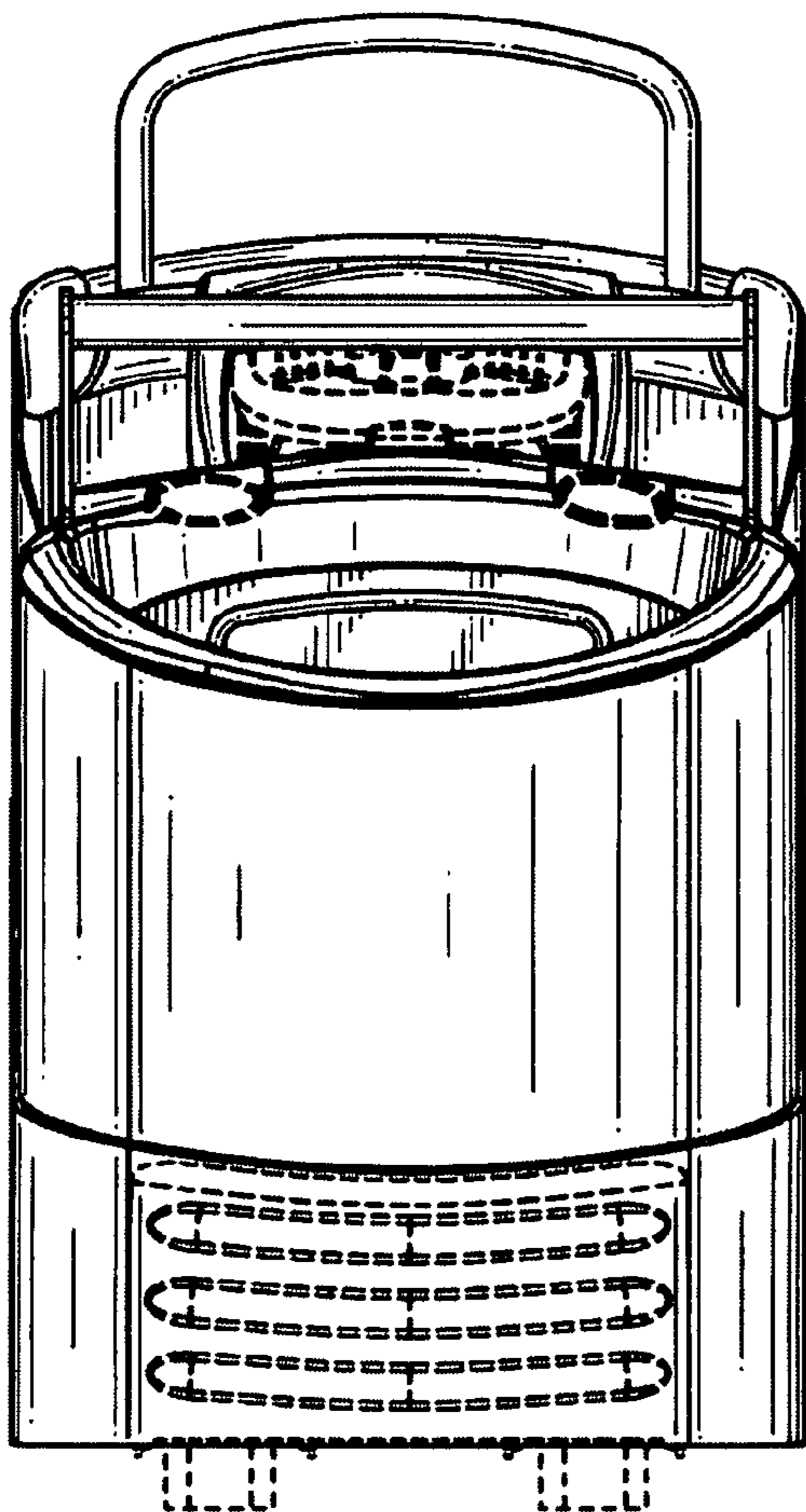
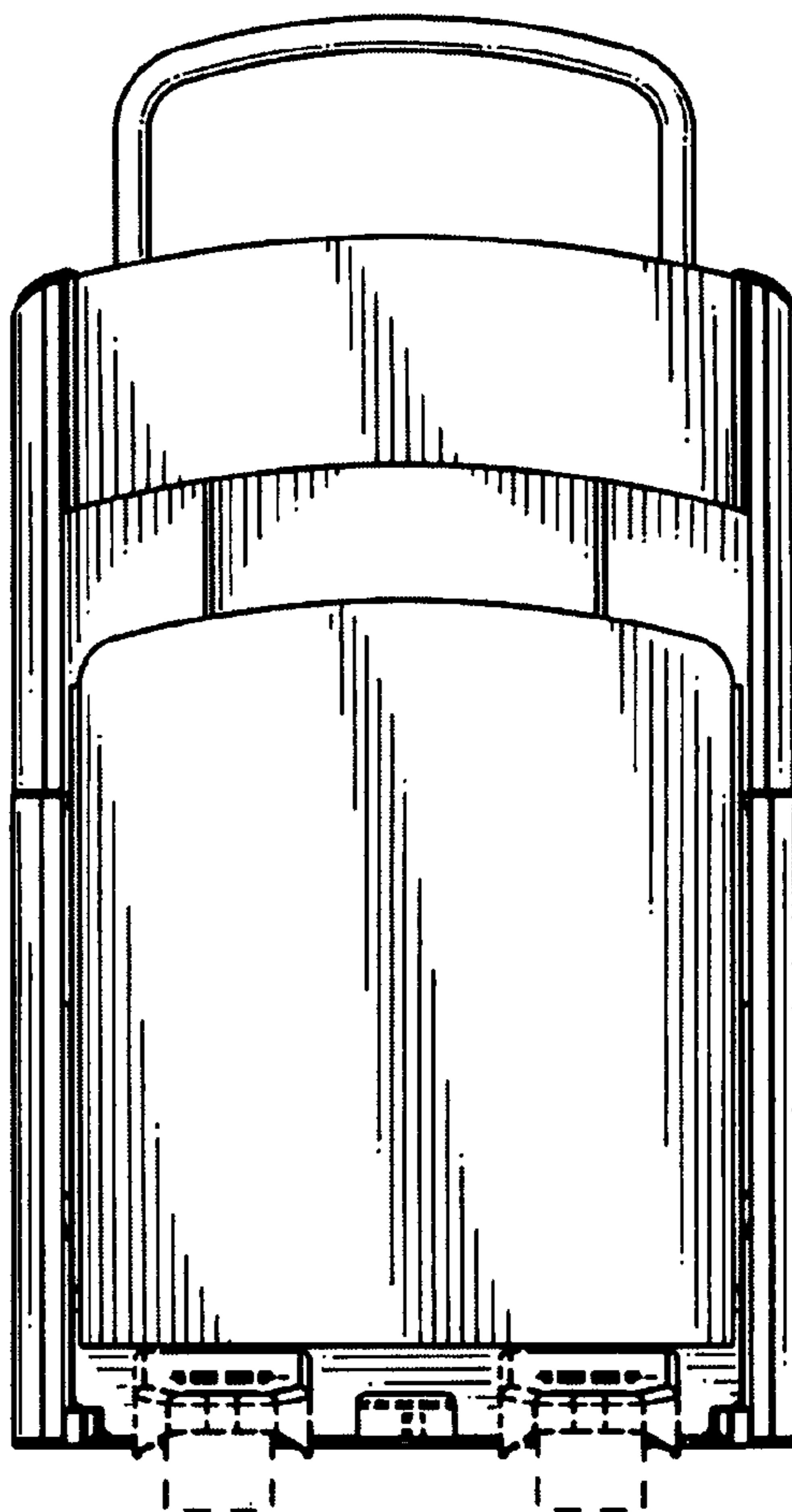

FIG. 6