



US00D562435S

(12) **United States Design Patent**
Turnbull

(10) **Patent No.:** **US D562,435 S**

(45) **Date of Patent:** **** *Feb. 19, 2008**

(54) **SPRAY GUN TRIGGER**

(75) Inventor: **Clifford W. Turnbull**, Auburn, WA
(US)

(73) Assignee: **Trade Associates, Inc.**, Kent, WA (US)

(*) Notice: This patent is subject to a terminal disclaimer.

(**) Term: **14 Years**

(21) Appl. No.: **29/237,861**

(22) Filed: **Sep. 6, 2005**

(51) **LOC (8) Cl.** **23-01**

(52) **U.S. Cl.** **D23/226**

(58) **Field of Classification Search** D23/213,
D23/223, 226; 239/525-527; 222/402.1,
222/402.15

See application file for complete search history.

(56) **References Cited**

U.S. PATENT DOCUMENTS

3,734,406 A	5/1973	Runstadler, Jr. et al.	239/8
3,896,994 A	7/1975	Walberg	239/3
4,456,180 A	6/1984	Lury	239/397
4,483,483 A	11/1984	Grime	239/526
4,537,357 A	8/1985	Culbertson et al.	239/290
4,739,933 A	4/1988	Hanano	239/304
4,805,814 A	2/1989	Allen, Sr.	222/538
4,817,872 A	4/1989	Mattson	239/300
4,959,159 A	9/1990	Mattson	239/526
5,094,402 A	3/1992	Perret, Jr. et al.	239/526
5,271,564 A	12/1993	Smith	239/532

5,469,993 A	11/1995	Hauf et al.	222/383.3
D376,318 S *	12/1996	Hildebrand	D9/448
5,609,302 A	3/1997	Smith	239/526
6,029,909 A	2/2000	Smith	239/318
6,168,093 B1	1/2001	Greer, Jr. et al.	239/332
6,319,453 B1	11/2001	Klima, Jr. et al.	264/504
D488,535 S *	4/2004	Foster et al.	D23/226
D495,779 S *	9/2004	Turnbull et al.	D23/226
D504,493 S *	4/2005	Huang	D23/226
D505,072 S	5/2005	Turnbull et al.	D9/448

* cited by examiner

Primary Examiner—Robin V Webster

(74) *Attorney, Agent, or Firm*—Dorsey & Whitney, LLP

(57) **CLAIM**

The ornamental design for a spray gun trigger, as shown and described.

DESCRIPTION

FIG. 1 is a front isometric view of a spray gun apparatus showing our new design.

FIG. 2 is a right side elevational view thereof.

FIG. 3 is a left side elevational view thereof.

FIG. 4 is a top plan view thereof.

FIG. 5 is a bottom plan view thereof.

FIG. 6 is a front elevational view thereof; and,

FIG. 7 is a back elevational view thereof.

The broken line showing is included for the purpose of illustrating and forms no part of the claimed design.

1 Claim, 6 Drawing Sheets

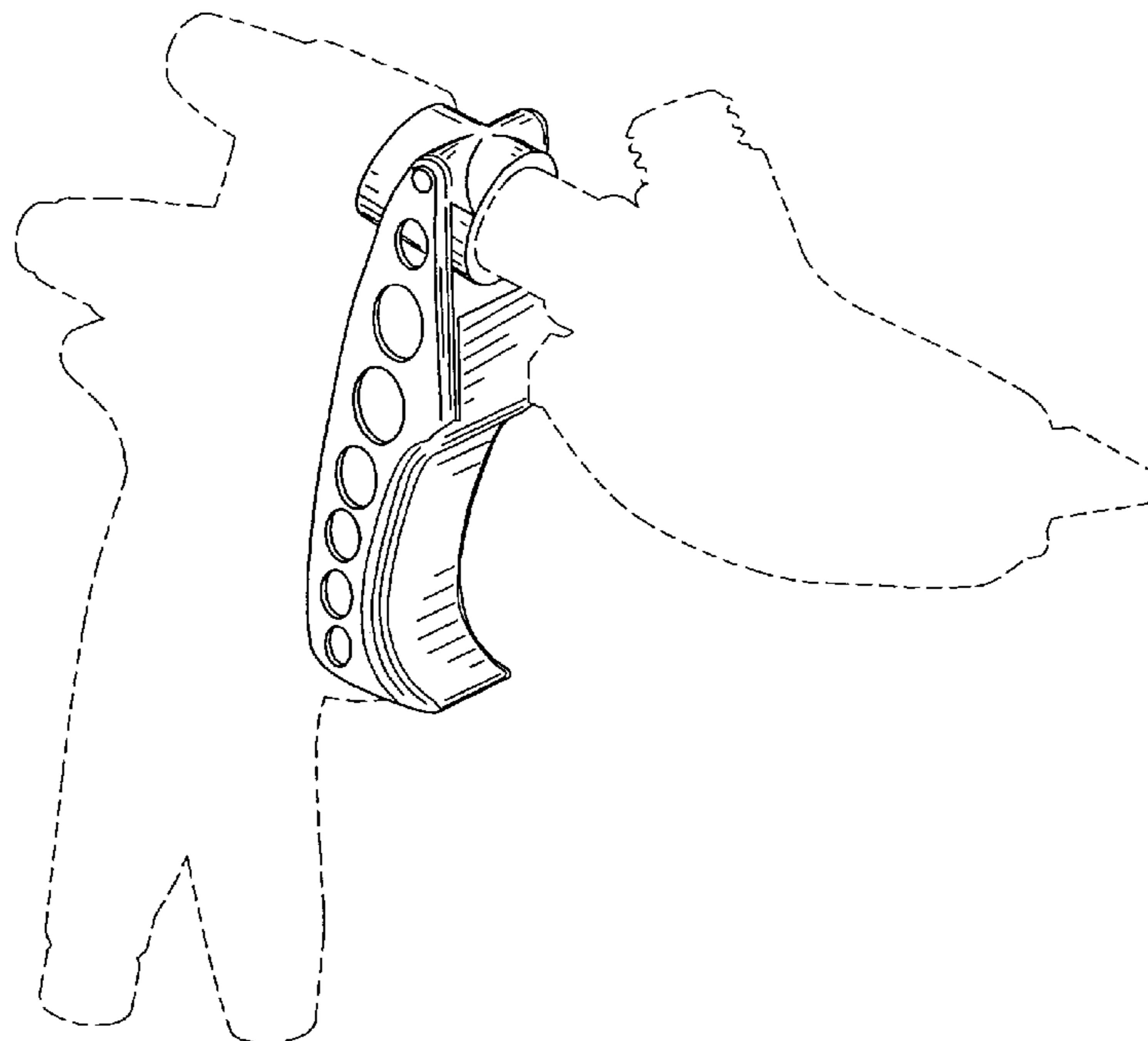

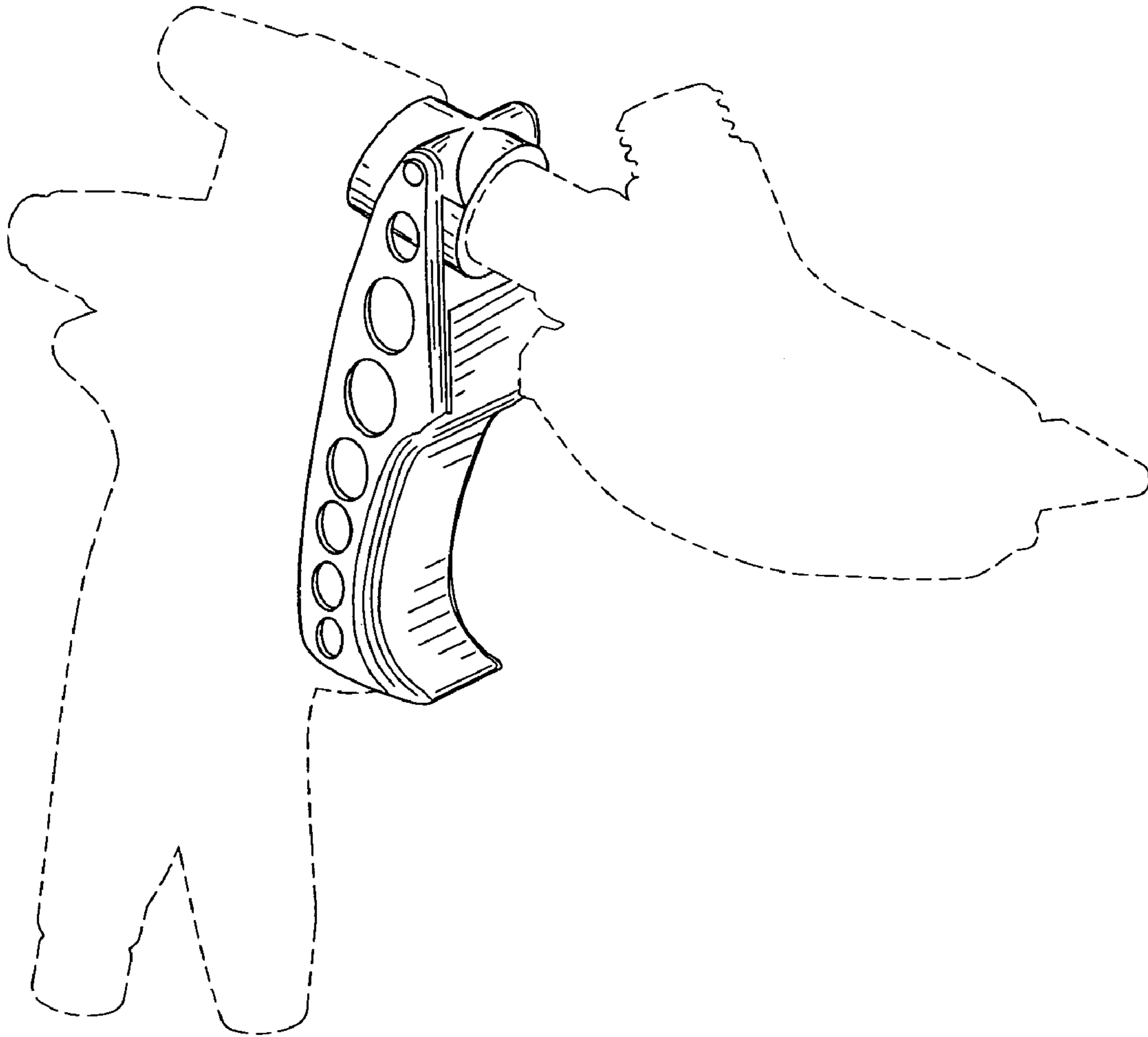

FIG.1

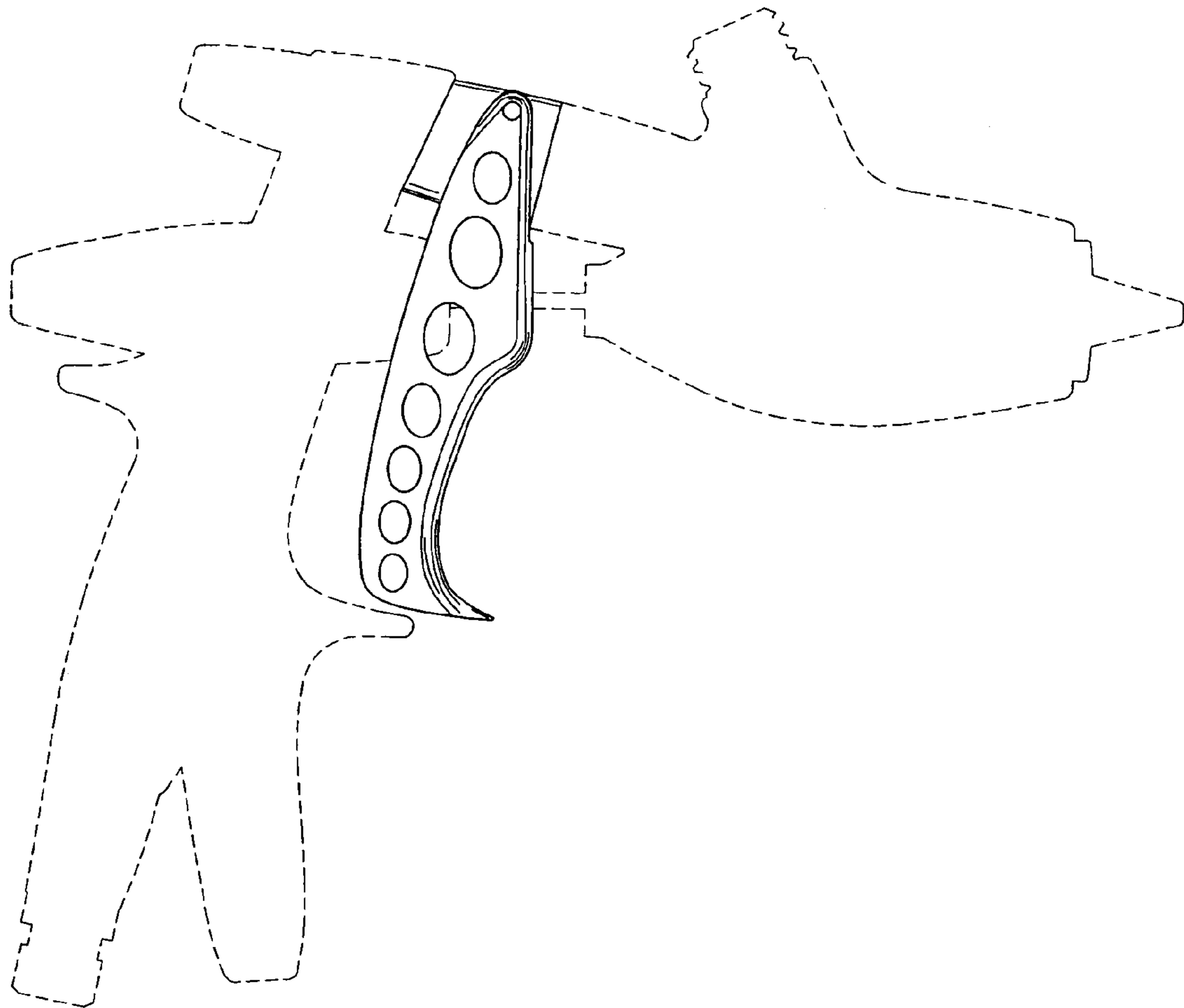

FIG.2

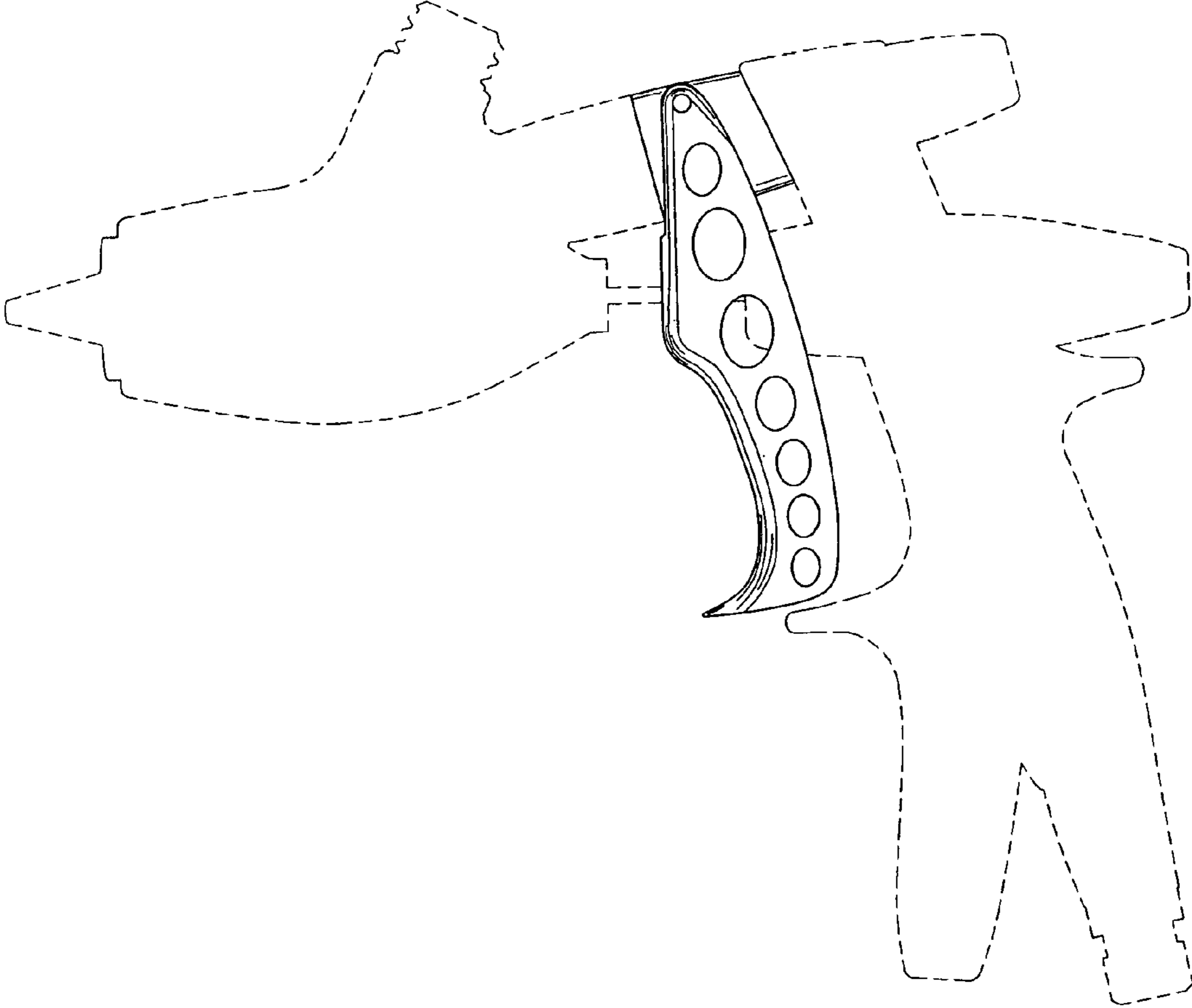

FIG. 3

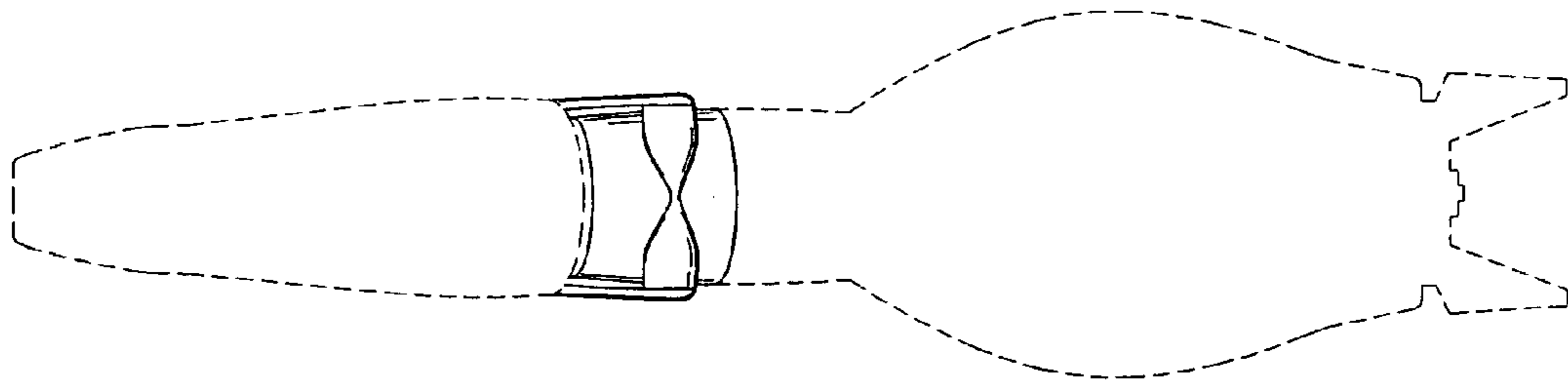

FIG. 4

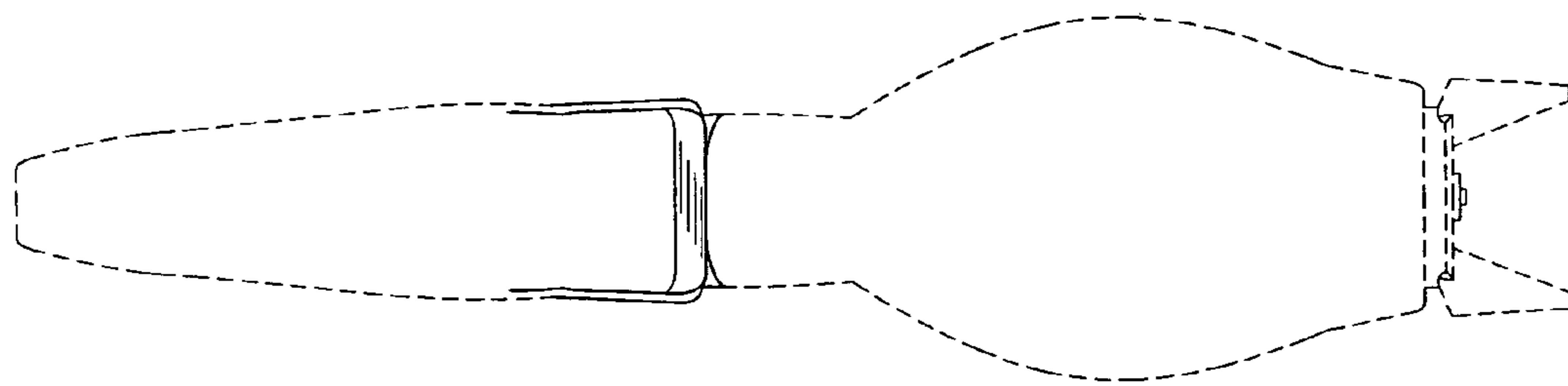

FIG. 5

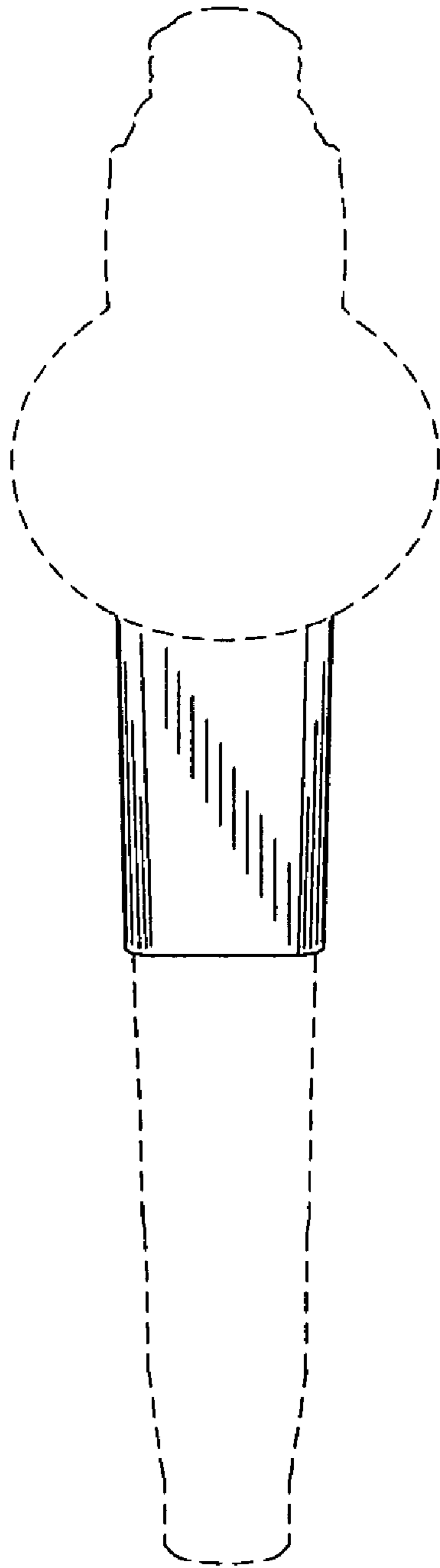

FIG. 6

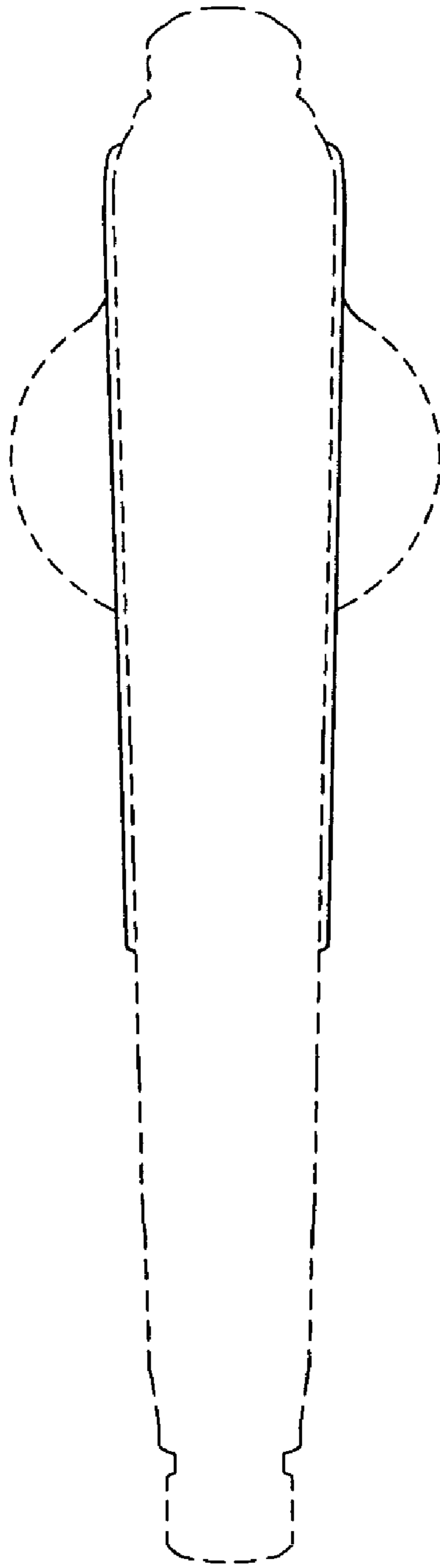

FIG. 7