

US00D562238S

(12) **United States Design Patent**
Nozaki et al.

(10) **Patent No.:** **US D562,238 S**
(45) **Date of Patent:** **** *Feb. 19, 2008**

(54) **HYDRAULIC GENERATOR**

(75) Inventors: **Takashi Nozaki**, Ise (JP); **Yoshinori Takahashi**, Ise (JP); **Nobuhiro Saito**, Ise (JP); **Hideki Sakurai**, Ise (JP); **Akira Ishikura**, Ise (JP); **Tsuyoshi Muraoka**, Ise (JP)

D285,077 S * 8/1986 Moody D15/1
D309,288 S * 7/1990 Haverly D13/114
D416,537 S * 11/1999 Imai et al. D13/116
6,039,009 A * 3/2000 Hirose 123/2
6,492,740 B2 * 12/2002 Suzuki 290/1 A
D494,928 S * 8/2004 Fan D13/112

(73) Assignee: **Shinko Electric Co., Ltd.**, Tokyo (JP)

* cited by examiner

(*) Notice: This patent is subject to a terminal disclaimer.

Primary Examiner—Prabhakar Deshmukh

Assistant Examiner—Derrick Holland

(**) Term: **14 Years**

(74) *Attorney, Agent, or Firm*—Steptoe & Johnson LLP

(21) Appl. No.: **29/262,735**

(57) **CLAIM**

(22) Filed: **Jul. 11, 2006**

The ornamental design for a hydraulic generator, as shown and described.

(30) **Foreign Application Priority Data**

DESCRIPTION

Jan. 11, 2006 (JP) 2006-000306

(51) **LOC (8) Cl.** **13-01**

FIG. 1 is a perspective view of a hydraulic generator.

(52) **U.S. Cl.** **D13/114**

FIG. 2 is a front elevation view thereof.

(58) **Field of Classification Search** D13/114,
D13/112, 122; 290/1 A; 361/679, 725, 727,
361/730

FIG. 3 is a rear elevation view thereof.

FIG. 4 is a top plan view thereof.

See application file for complete search history.

FIG. 5 is a bottom plan view thereof.

FIG. 6 is a left side elevation view thereof; and,

FIG. 7 is a right side elevation view thereof.

(56) **References Cited**

U.S. PATENT DOCUMENTS

D194,490 S * 1/1963 Winslow et al. D15/1

1 Claim, 7 Drawing Sheets

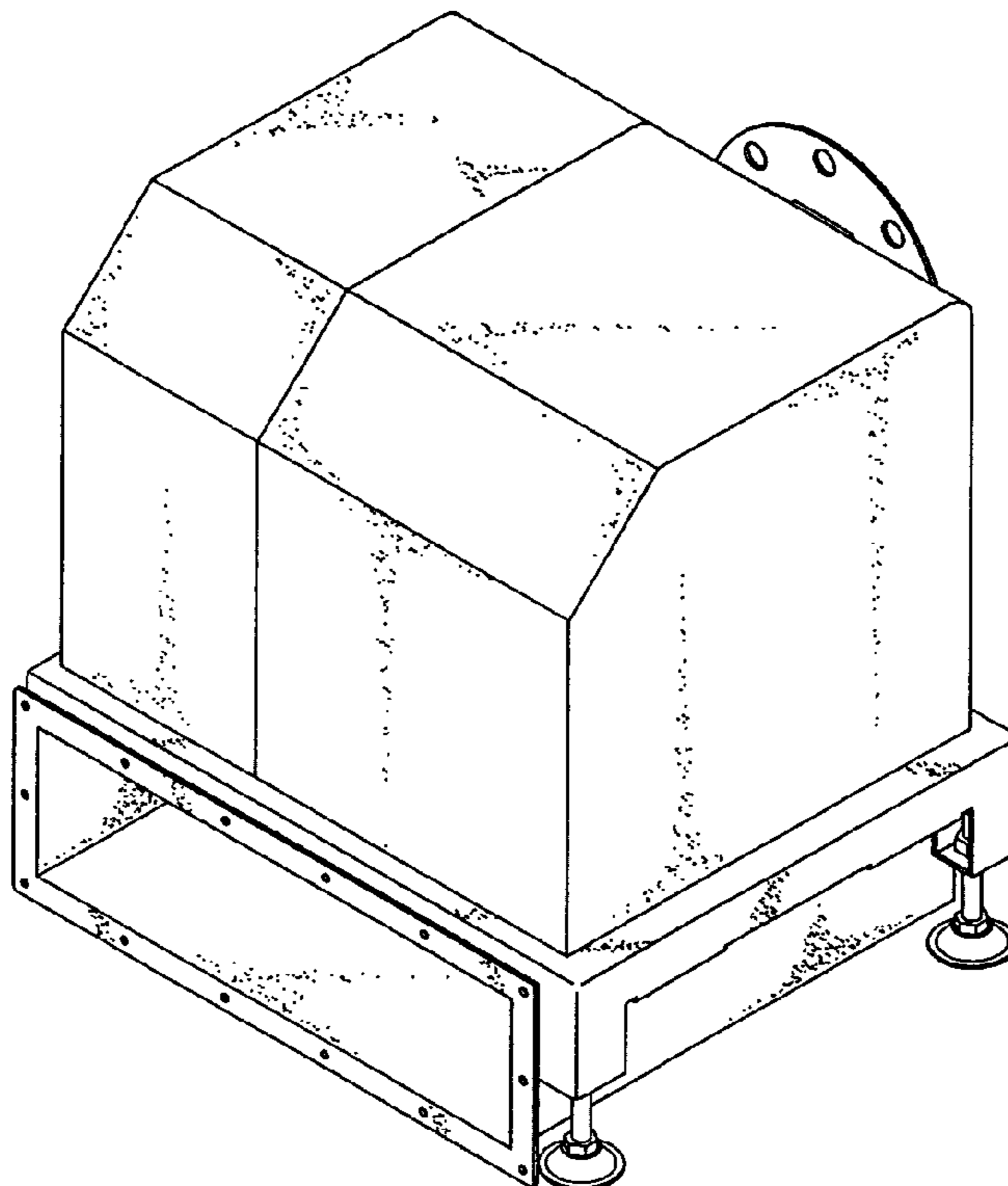

FIG. 1

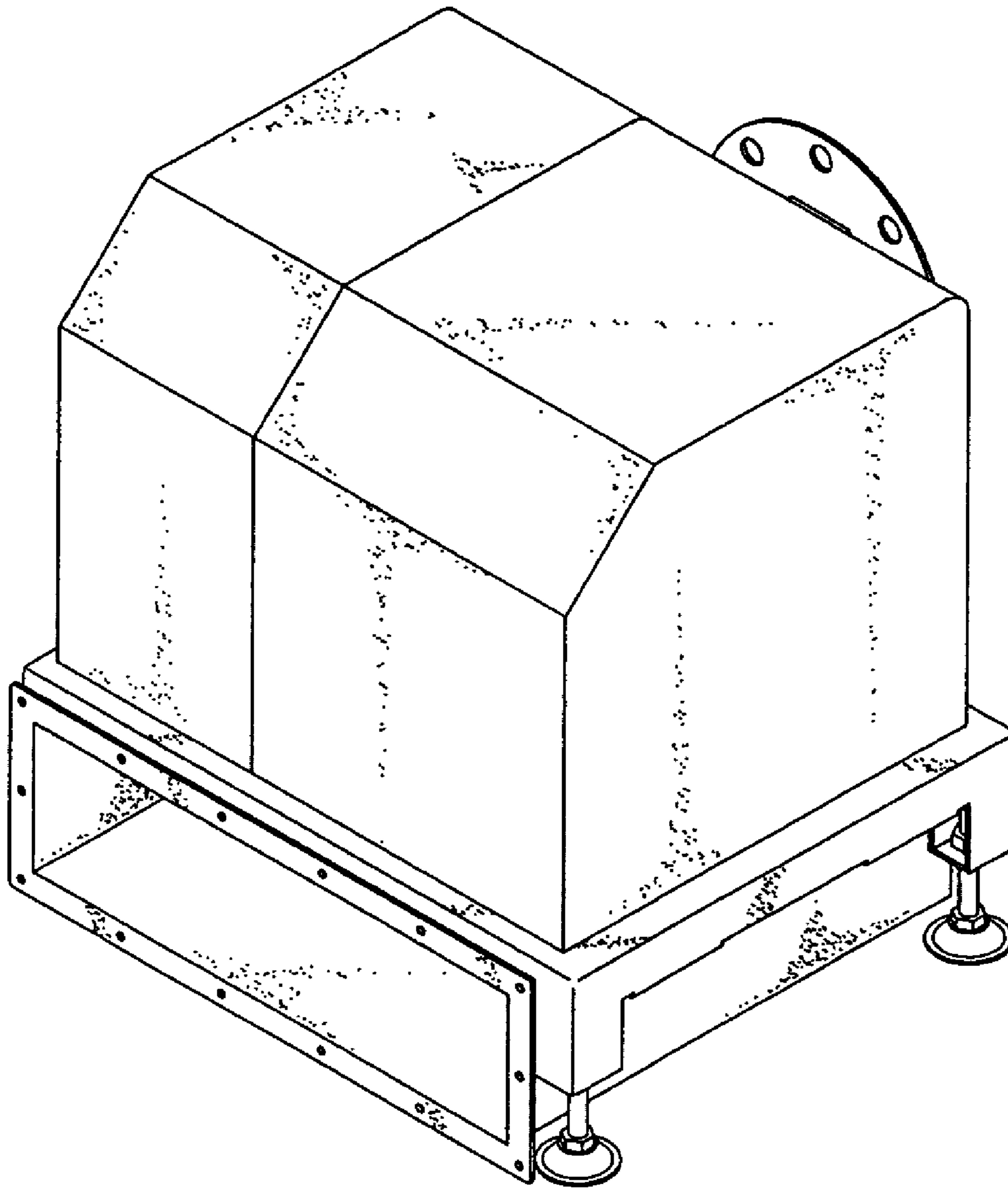

FIG. 2

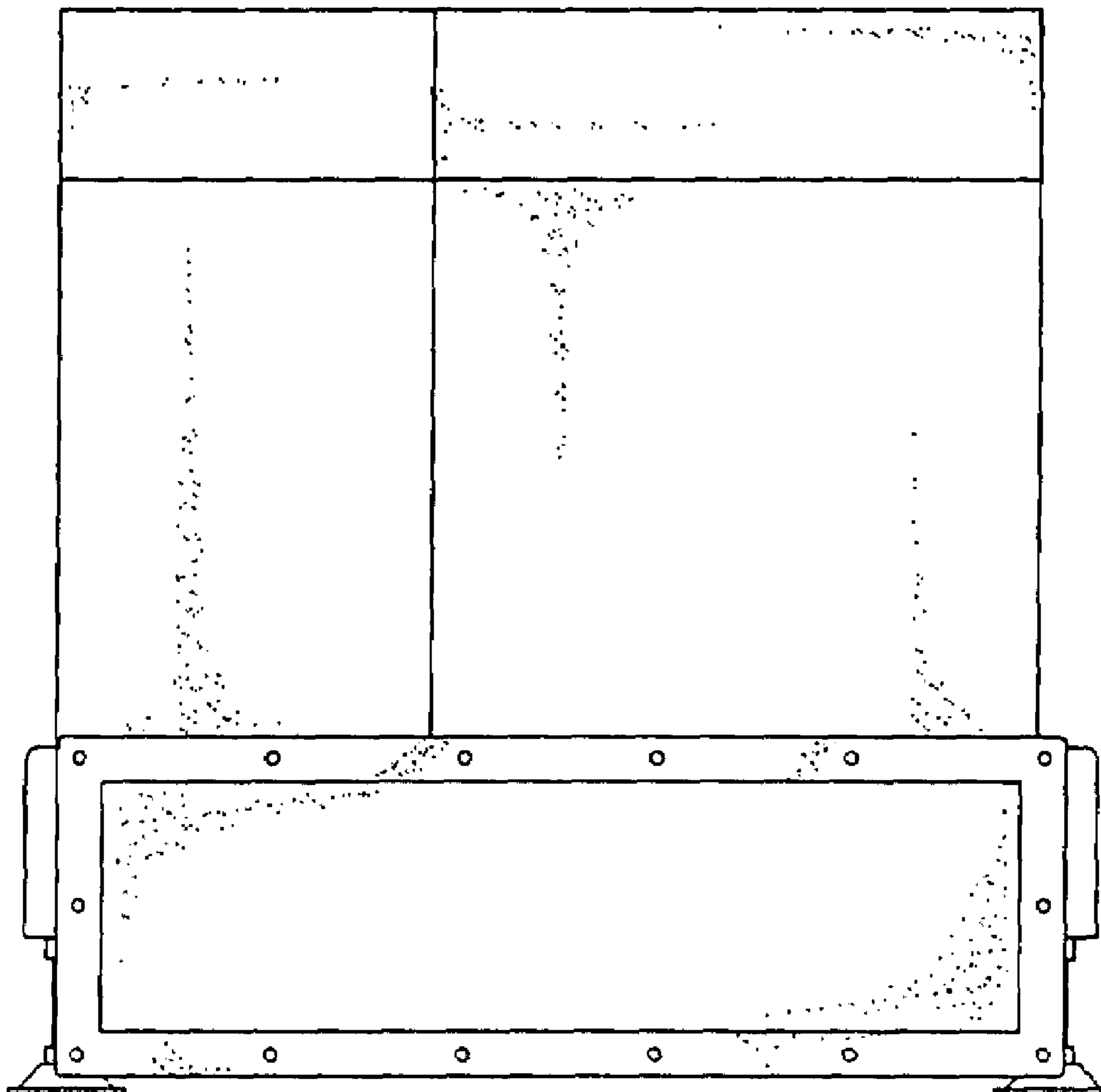

FIG. 3

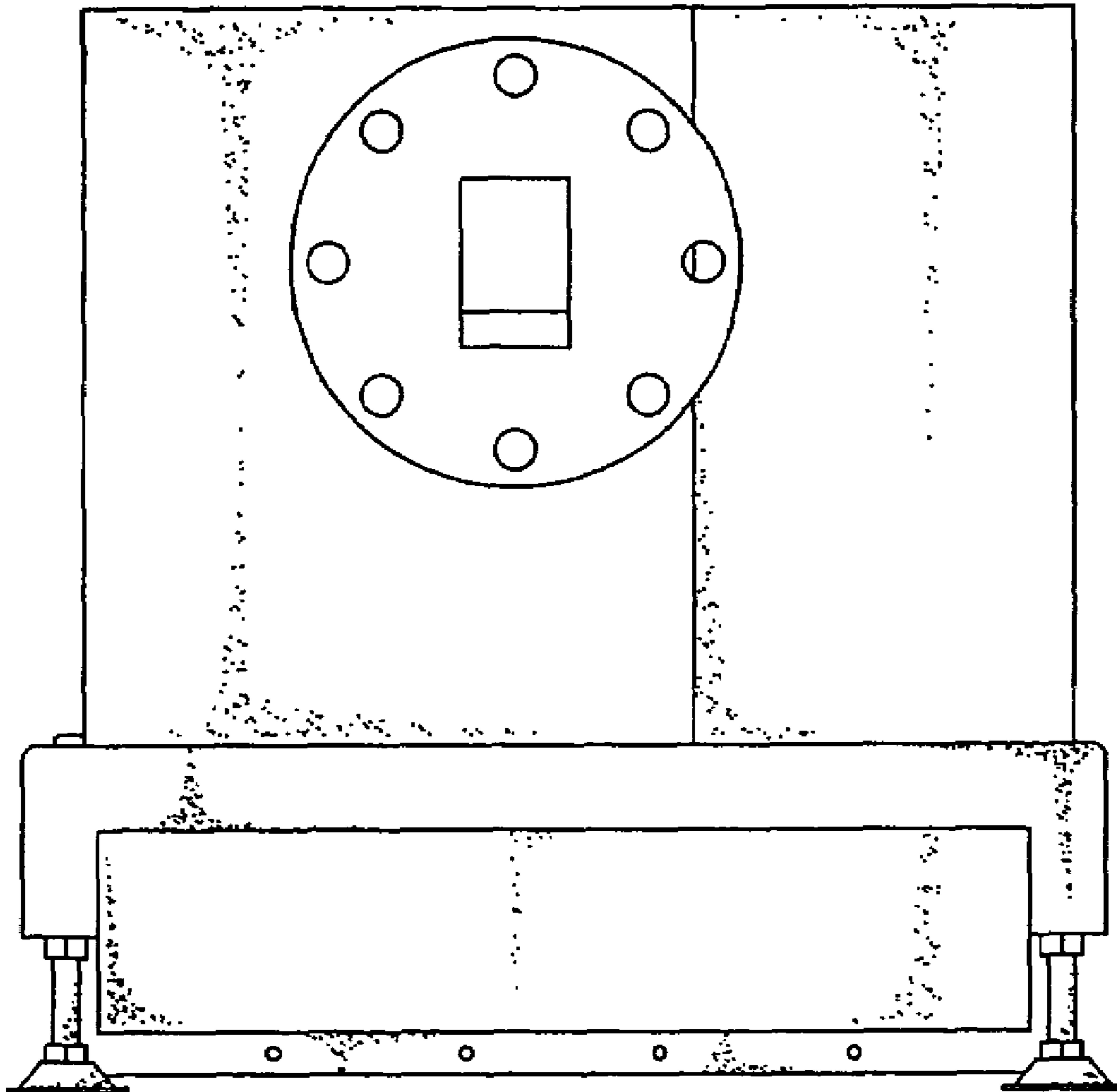

FIG. 4

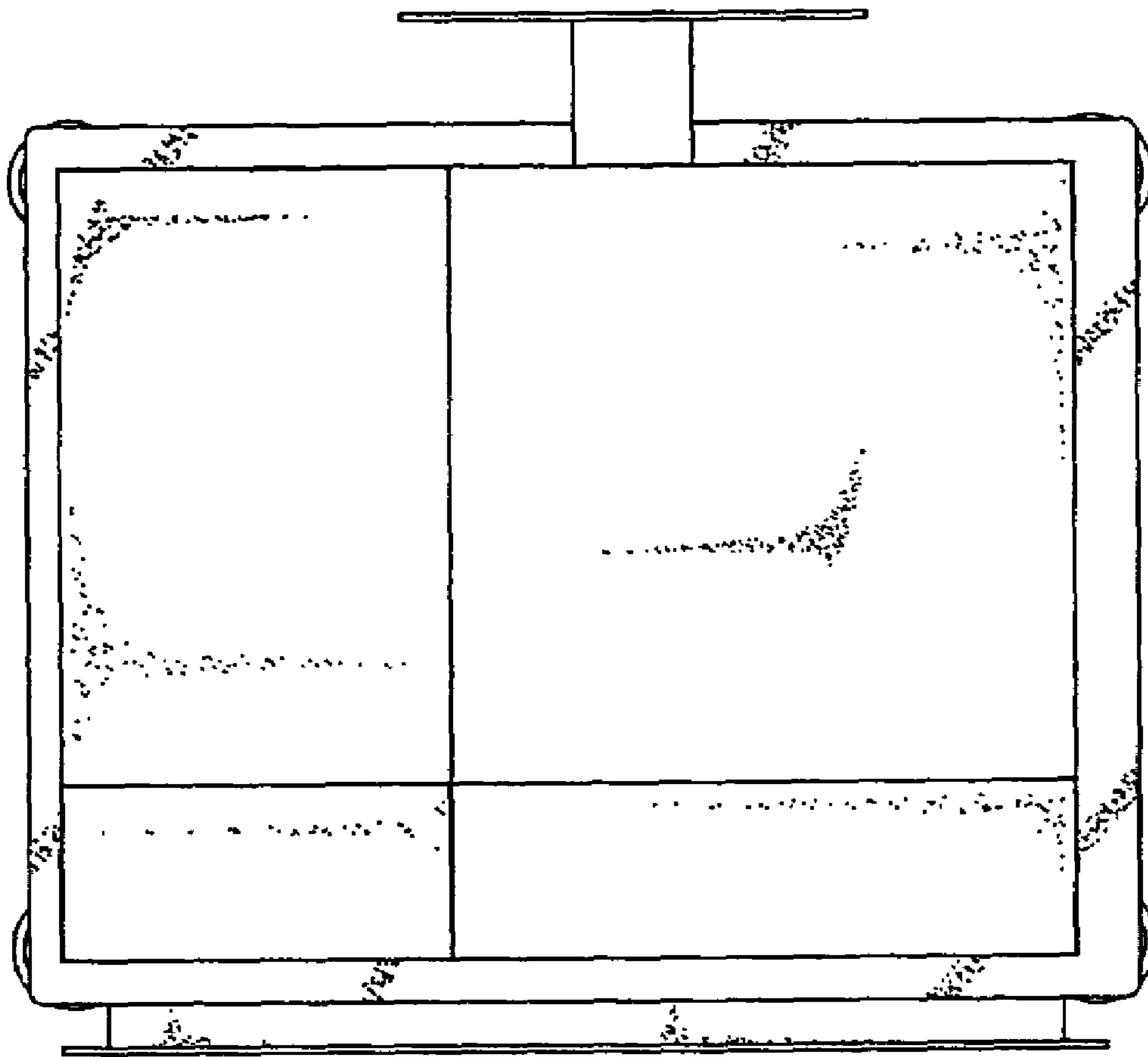

FIG. 5

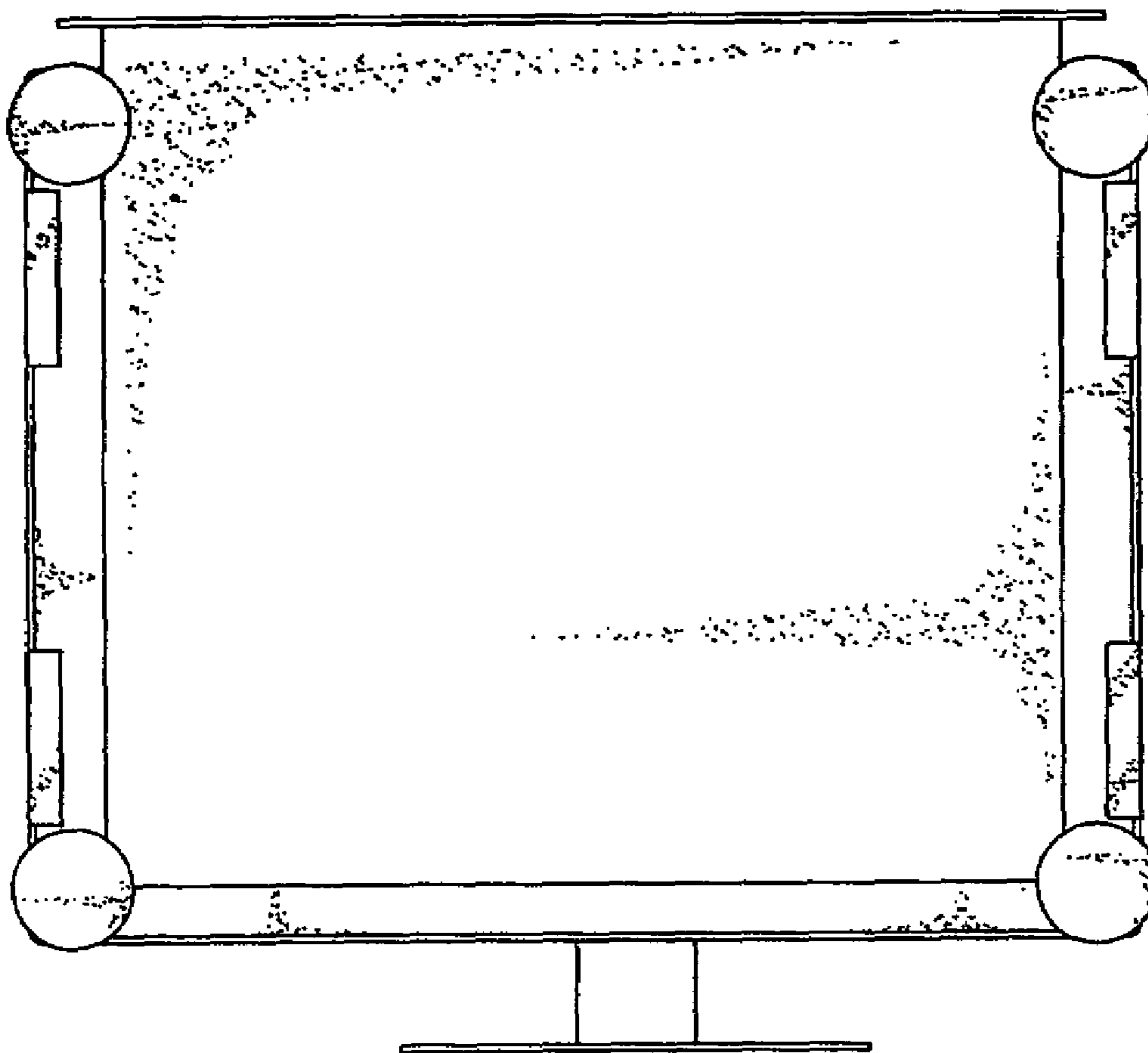

FIG. 6

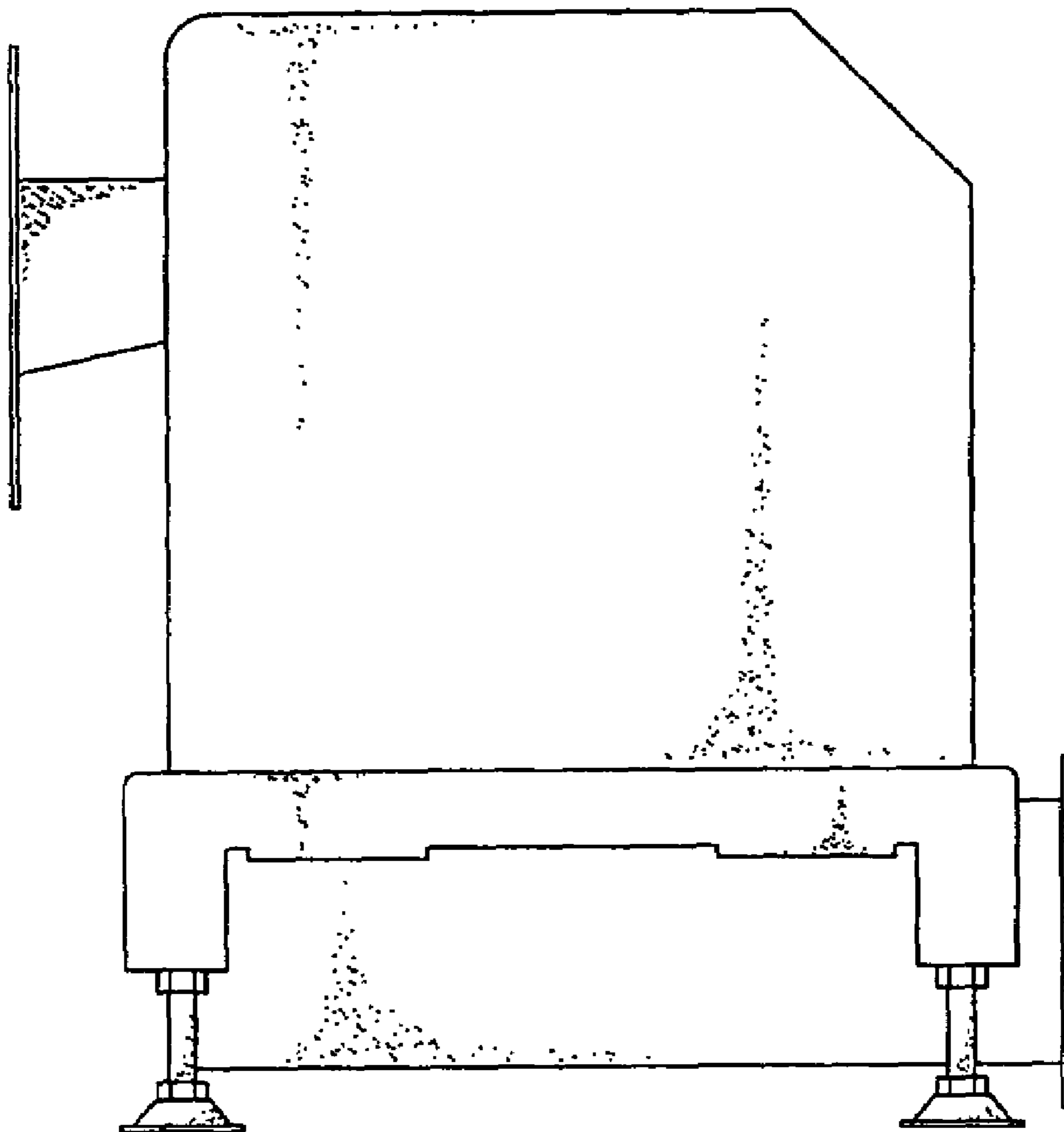

FIG. 7

