



US00D562230S

(12) **United States Design Patent**
Houghton

(10) **Patent No.:** **US D562,230 S**

(45) **Date of Patent:** **** Feb. 19, 2008**

(54) **CHARGING UNIT FOR TWO BATTERY PACKS**

D550,615 S * 9/2007 Tong D13/107
D551,617 S * 9/2007 Houghton D13/108

(75) Inventor: **Stephen Houghton**, High West
Jesmond (GB)

* cited by examiner

(73) Assignee: **Black & Decker Inc.**, Newark, DE
(US)

Primary Examiner—Cathron Brooks

Assistant Examiner—Rosemary K Tarcza

(74) *Attorney, Agent, or Firm*—John Yun; Bruce S. Shapiro;
Wesley Muller

(**) Term: **14 Years**

(57) **CLAIM**

(21) Appl. No.: **29/273,888**

The ornamental design for a charging unit for two battery packs, as shown and described.

(22) Filed: **Mar. 15, 2007**

(30) **Foreign Application Priority Data**

DESCRIPTION

Sep. 18, 2006 (EM) 000589304

FIG. 1 is a top perspective view of a charging unit for two battery packs showing my new design;

(51) **LOC (8) Cl.** **13-02**

FIG. 2 is a top view of a charging unit for two battery packs according to FIG. 1;

(52) **U.S. Cl.** **D13/107**

(58) **Field of Classification Search** D13/107–110,
D13/118–119, 184; D14/251, 253, 432,
D14/434; 320/107–115

FIG. 3 is a bottom view of a charging unit for two battery packs according to FIG. 1;

See application file for complete search history.

FIG. 4 is a right side view of a charging unit for two battery packs according to FIG. 1;

(56) **References Cited**

FIG. 5 is a left side view of a charging unit for two battery packs according to FIG. 1;

U.S. PATENT DOCUMENTS

D322,061 S *	12/1991	Watanabe	D13/108
D408,352 S *	4/1999	Tashiro	D13/107
D455,397 S *	4/2002	Weiner et al.	D13/108
D506,725 S *	6/2005	Watson	D13/108
D506,972 S *	7/2005	Parel et al.	D13/107
D507,525 S *	7/2005	Heun	D13/107
D507,526 S *	7/2005	Ohta	D13/108
D522,963 S *	6/2006	Hayes et al.	D13/108
D530,667 S *	10/2006	Viduya et al.	D13/107

FIG. 6 is a front view of a charging unit for two battery packs according to FIG. 1;

FIG. 7 is a rear view of a charging unit for two battery packs according to FIG. 1; and,

FIG. 8 is a bottom perspective view of a charging unit for two battery packs of FIG. 1.

1 Claim, 8 Drawing Sheets

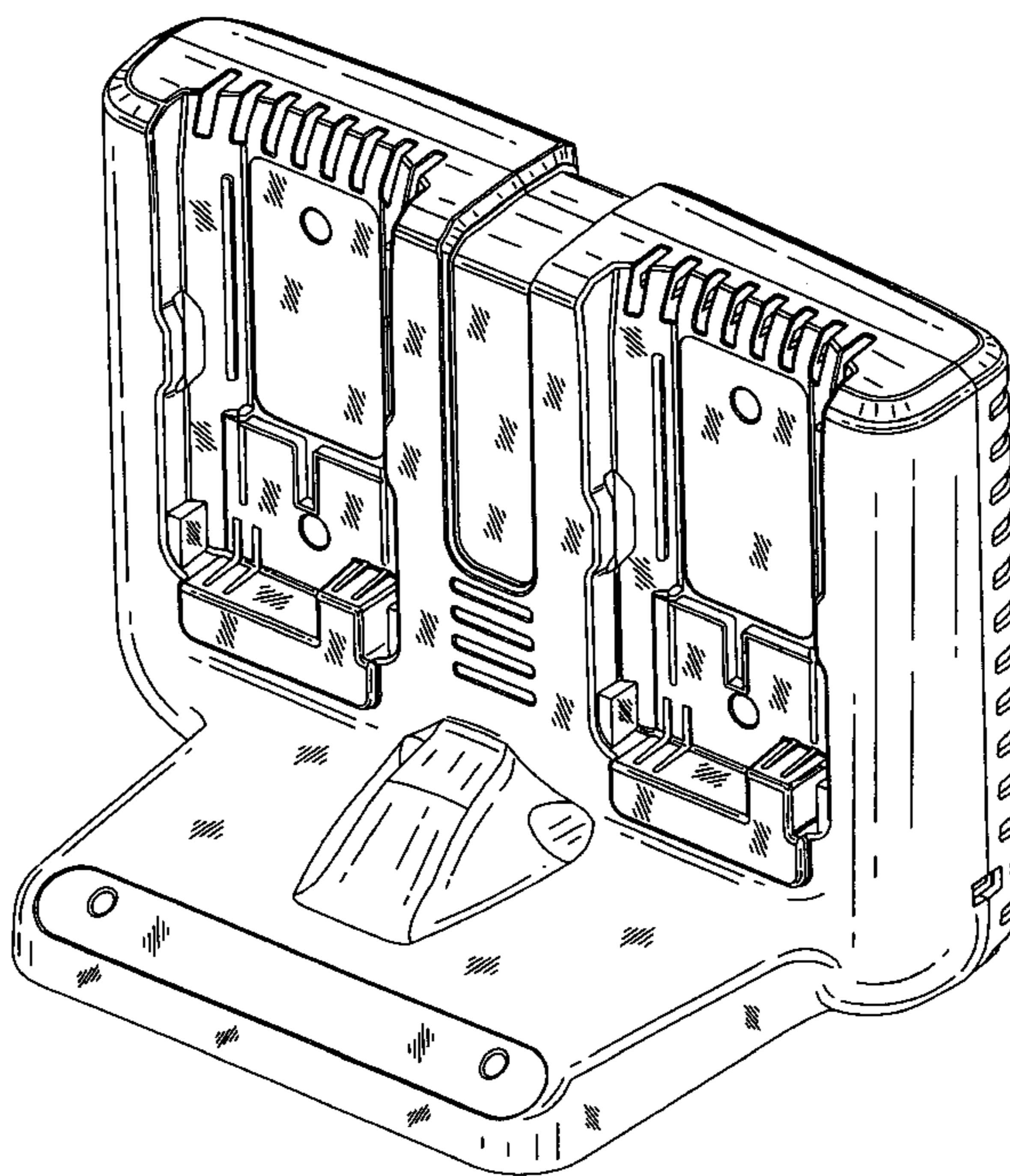

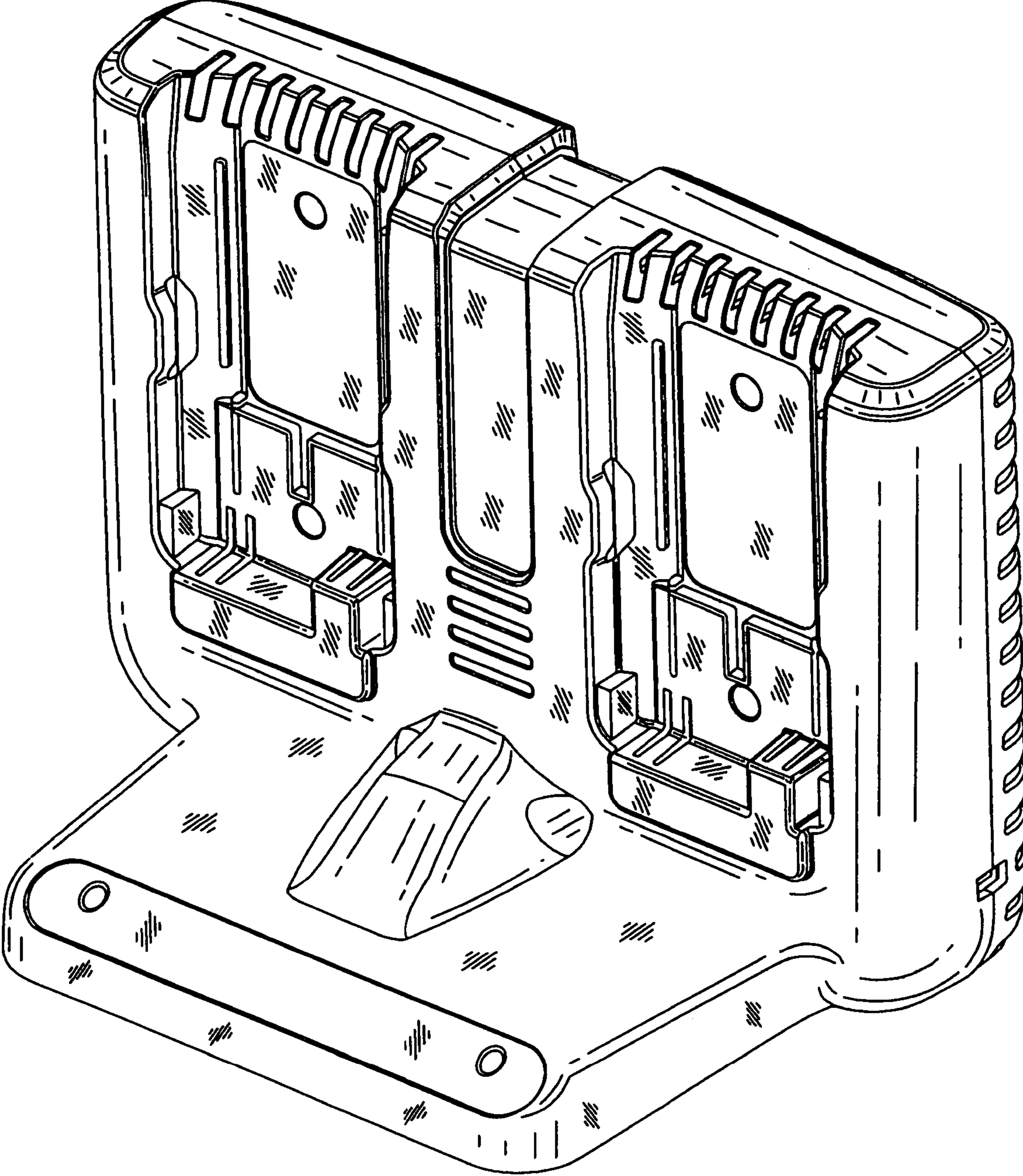

FIG.1

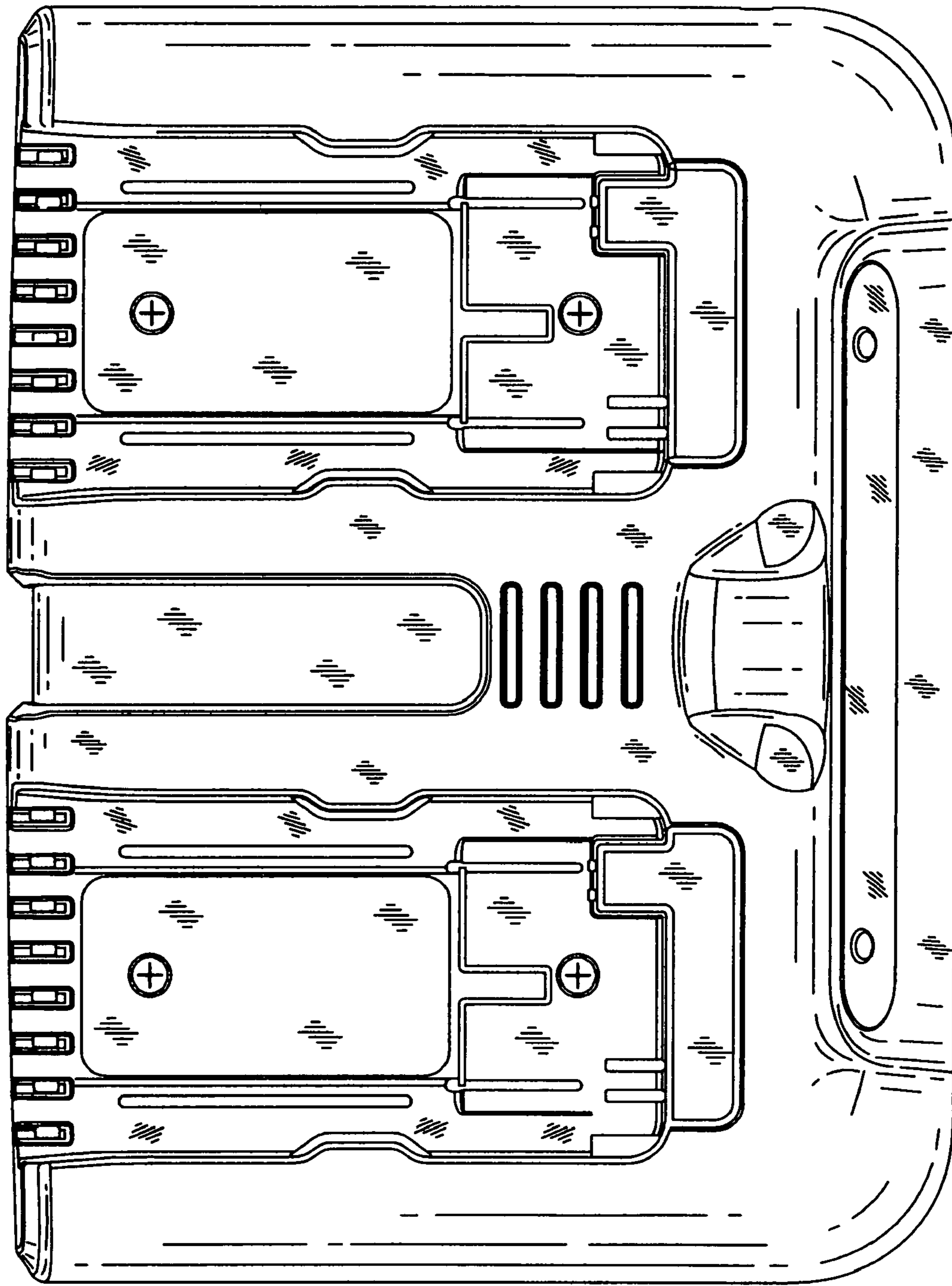

FIG.2

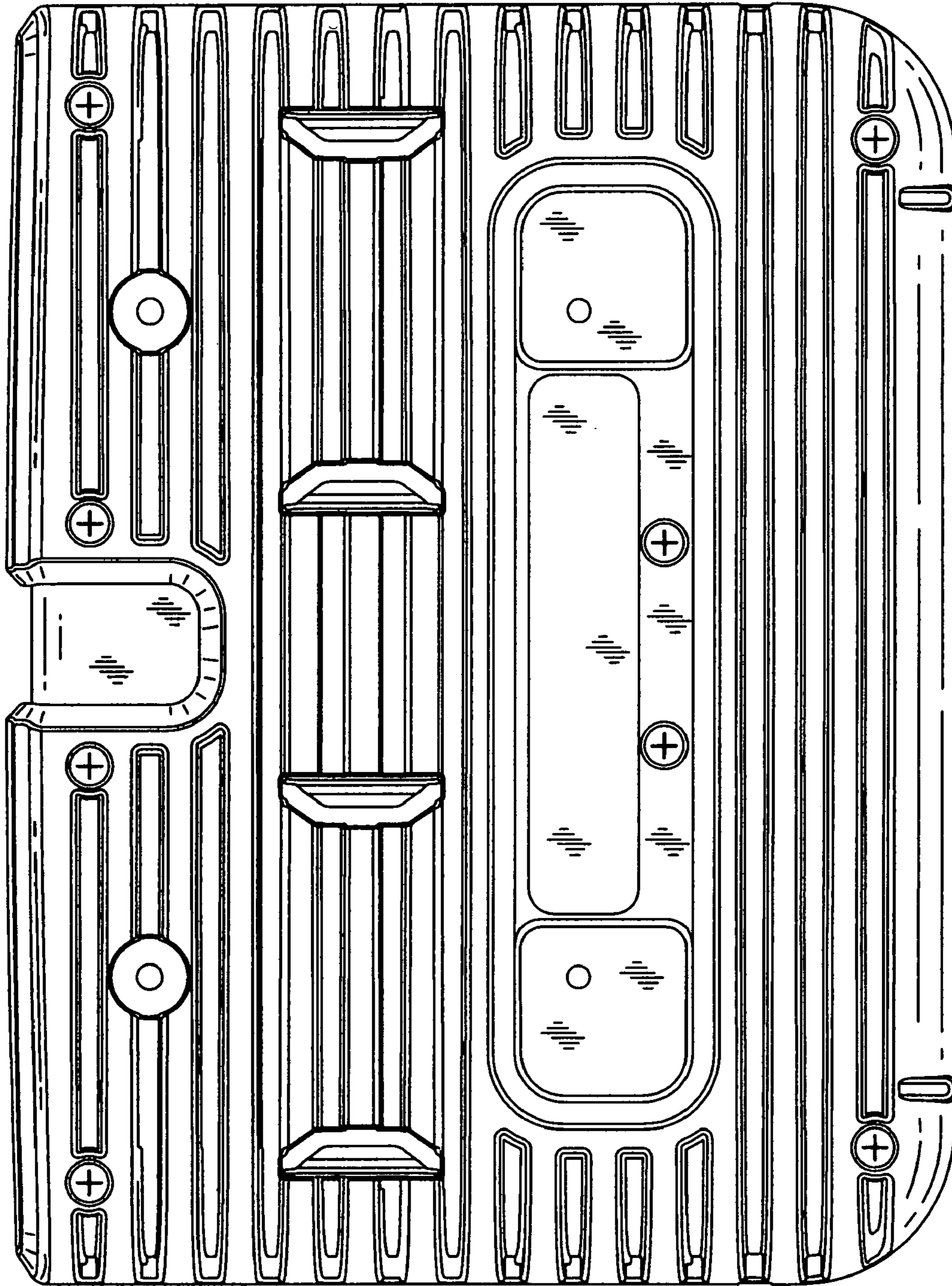

FIG.3

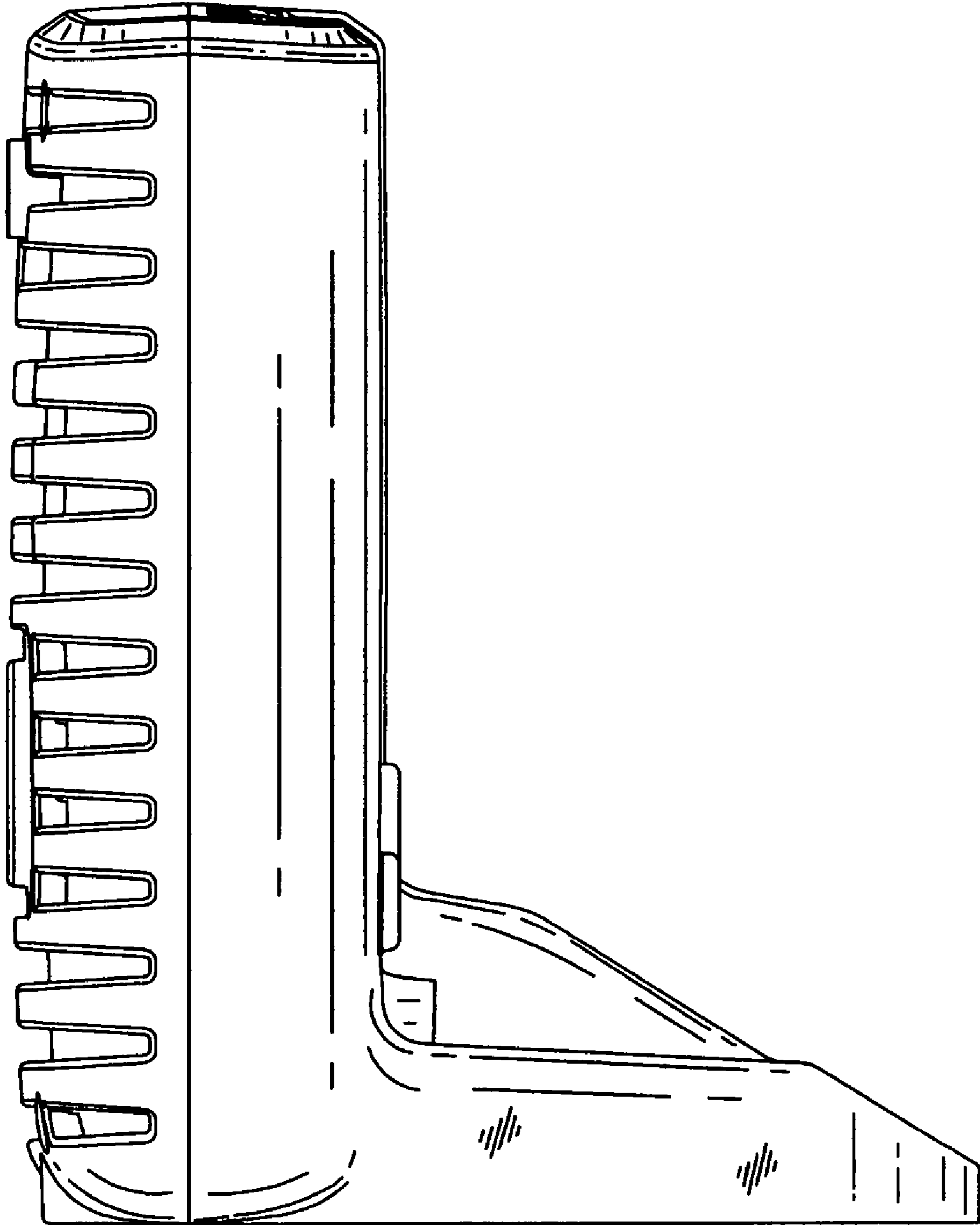

FIG.4

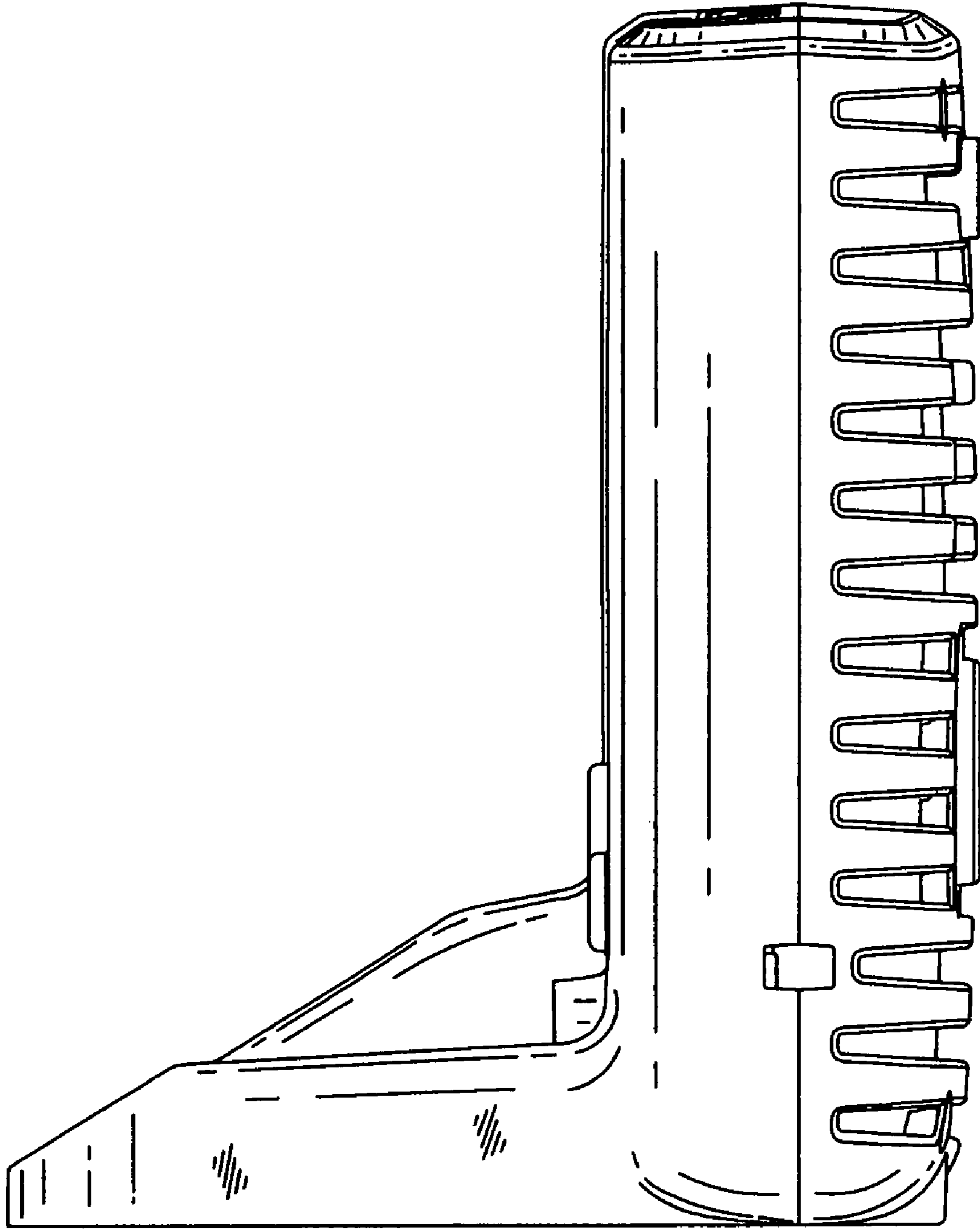

FIG.5

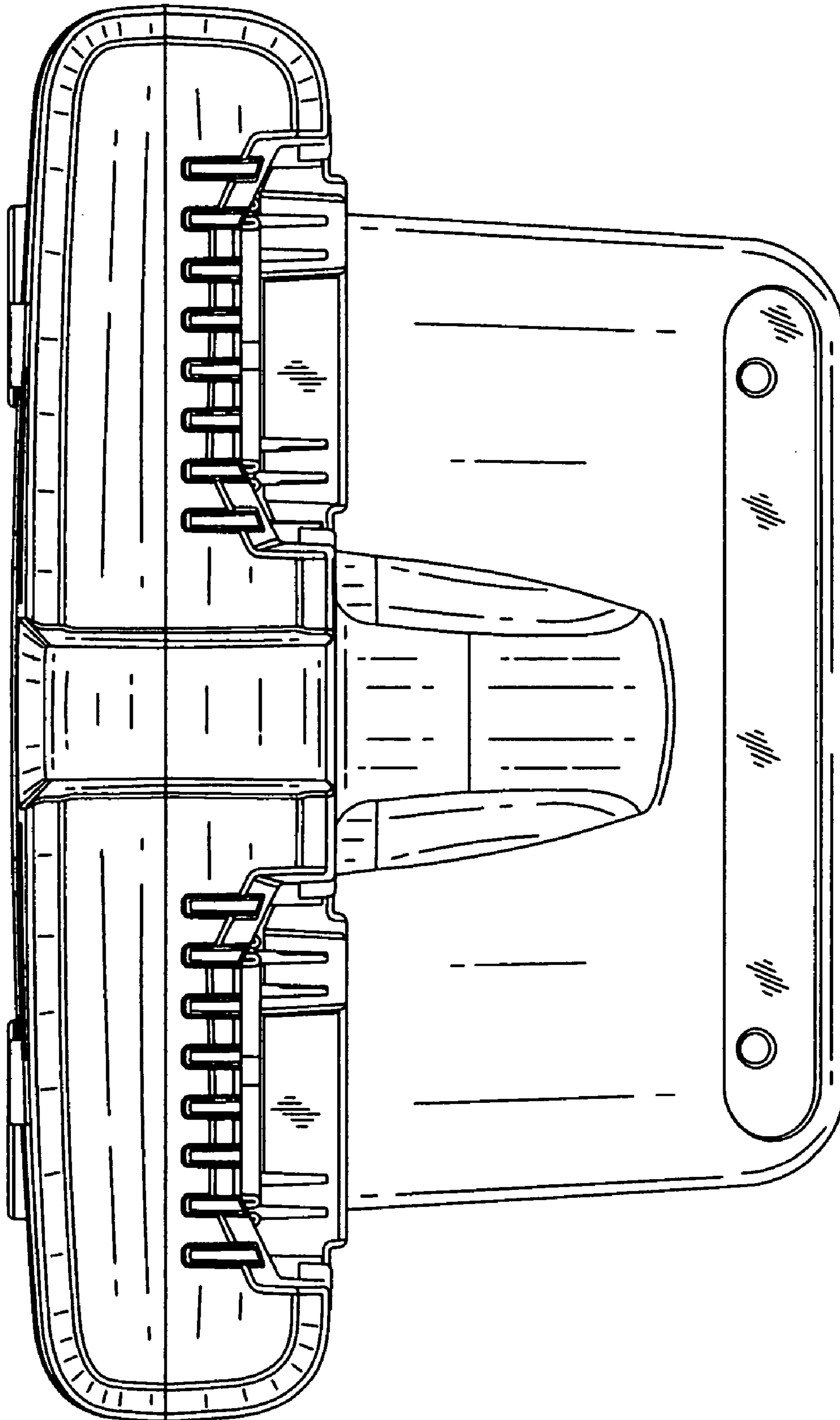

FIG.6

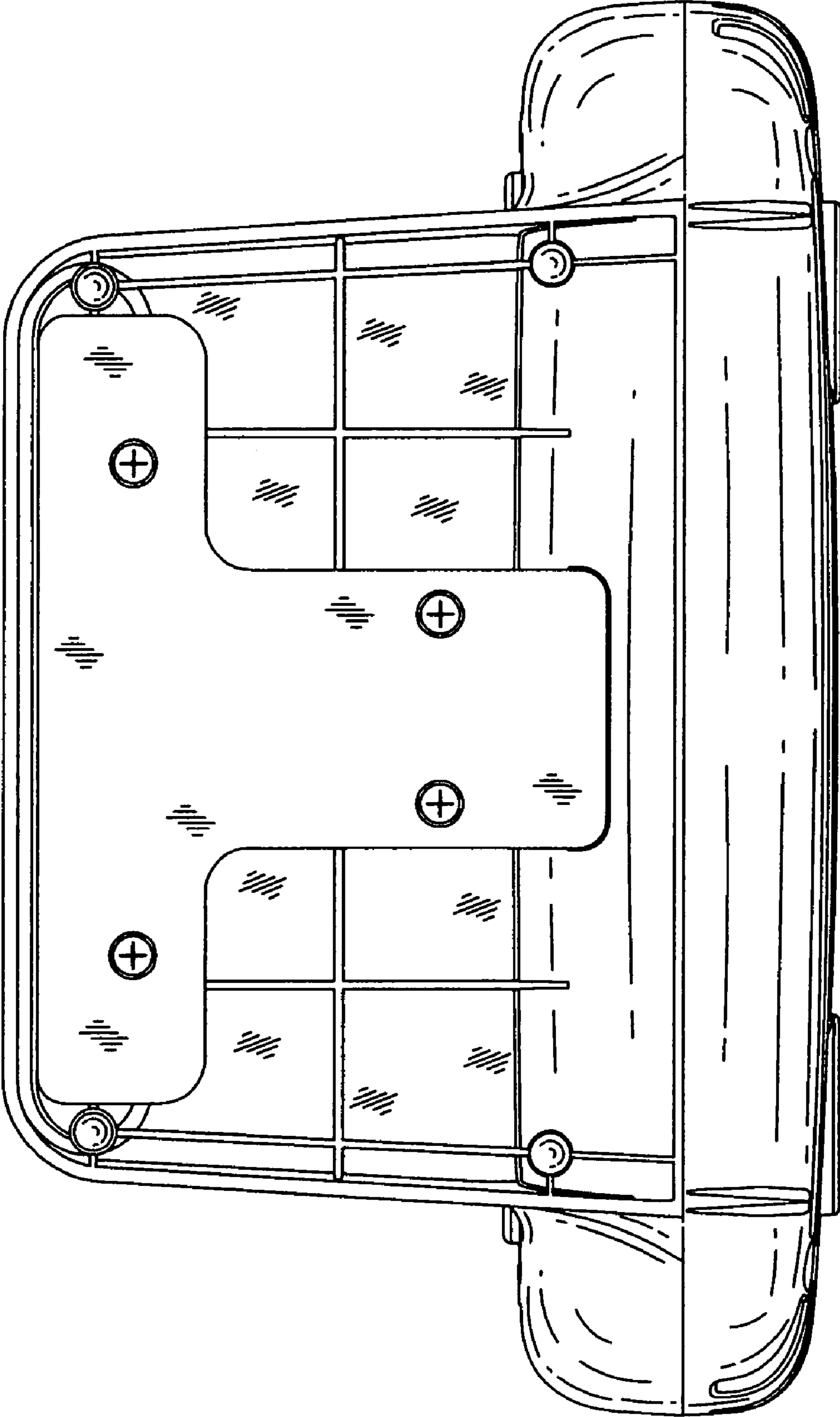

FIG.7

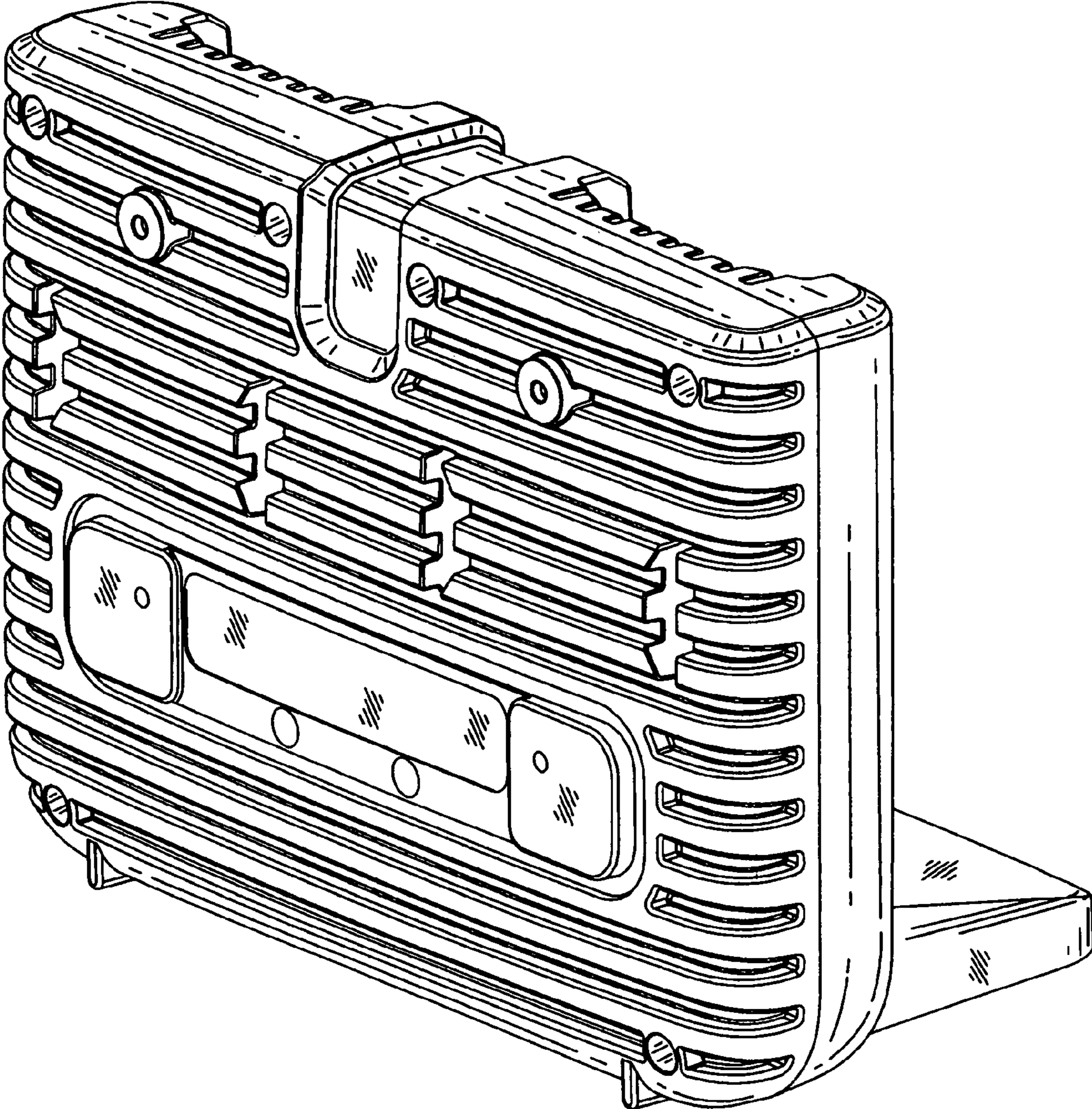

FIG.8