



US00D562217S

(12) **United States Design Patent**
Davis et al.

(10) **Patent No.:** **US D562,217 S**
(45) **Date of Patent:** **** Feb. 19, 2008**

(54) **WHEEL GRIPPING BICYCLE CARRIER**

4,524,893 A 6/1985 Cole

(75) Inventors: **Brian F. Davis**, Portland, OR (US);
Aaron J. Foley, Portland, OR (US);
Dominic M. D'Andrea, Portland, OR
(US); **Kevin E. Lesley**, Beaverton, OR
(US)

(Continued)

OTHER PUBLICATIONS

Roof Mounted Bike Racks sold by Bike Racks Plus. [Retrieved on Mar. 20, 2007]. © 2002-2005. Retrieved from the Internet <URL: http://www.bike-racks-plus.com/Roof_Mounted_Bike_Racks_y.htm>.*

(73) Assignee: **Yakima Products, Inc.**, Beaverton, OR
(US)

Primary Examiner—Cathron Brooks

Assistant Examiner—Linda Brooks

(**) Term: **14 Years**

(74) *Attorney, Agent, or Firm*—Kolisch Hartwell, P.C.

(21) Appl. No.: **29/256,750**

(57) **CLAIM**

(22) Filed: **Mar. 23, 2006**

I claim the ornamental design for a wheel gripping bicycle carrier, as shown and described.

(51) **LOC (8) Cl.** **12-11**

(52) **U.S. Cl.** **D12/408**

(58) **Field of Classification Search** D12/407,
D12/408, 412, 115, 120; 224/400, 401, 500-511,
224/522-537, 309-331, 324, 42.11, 42.12,
224/42.27, 42.29, 924; 414/462; 280/304.5,
280/202; 211/17-22

DESCRIPTION

See application file for complete search history.

FIG. 1 is a perspective view of a wheel gripping bicycle carrier;

FIG. 2 is a top view thereof;

FIGS. 3 and 5 are side views thereof;

FIG. 4 is a bottom view thereof;

FIG. 6 is a front view thereof; and,

FIG. 7 is a rear view thereof.

The shading lines shown in the drawing(s) represent the three-dimensional contour of the design, and are not intended to indicate surface decoration.

The broken lines immediately adjacent the shaded areas represent boundaries of the claimed design and form no part thereof, while the other broken lines show environmental elements which form no part of the claimed design.

(56) **References Cited**

U.S. PATENT DOCUMENTS

2,415,286 A	2/1947	Hyde
2,431,400 A	11/1947	Iverson
3,116,836 A	1/1964	McCauley
3,581,962 A	6/1971	Osborn
3,843,001 A	10/1974	Willis
3,861,533 A	1/1975	Radek
4,046,297 A	9/1977	Bland
4,126,228 A	11/1978	Bala et al.
4,437,597 A	3/1984	Doyle
4,442,961 A	4/1984	Bott

1 Claim, 2 Drawing Sheets

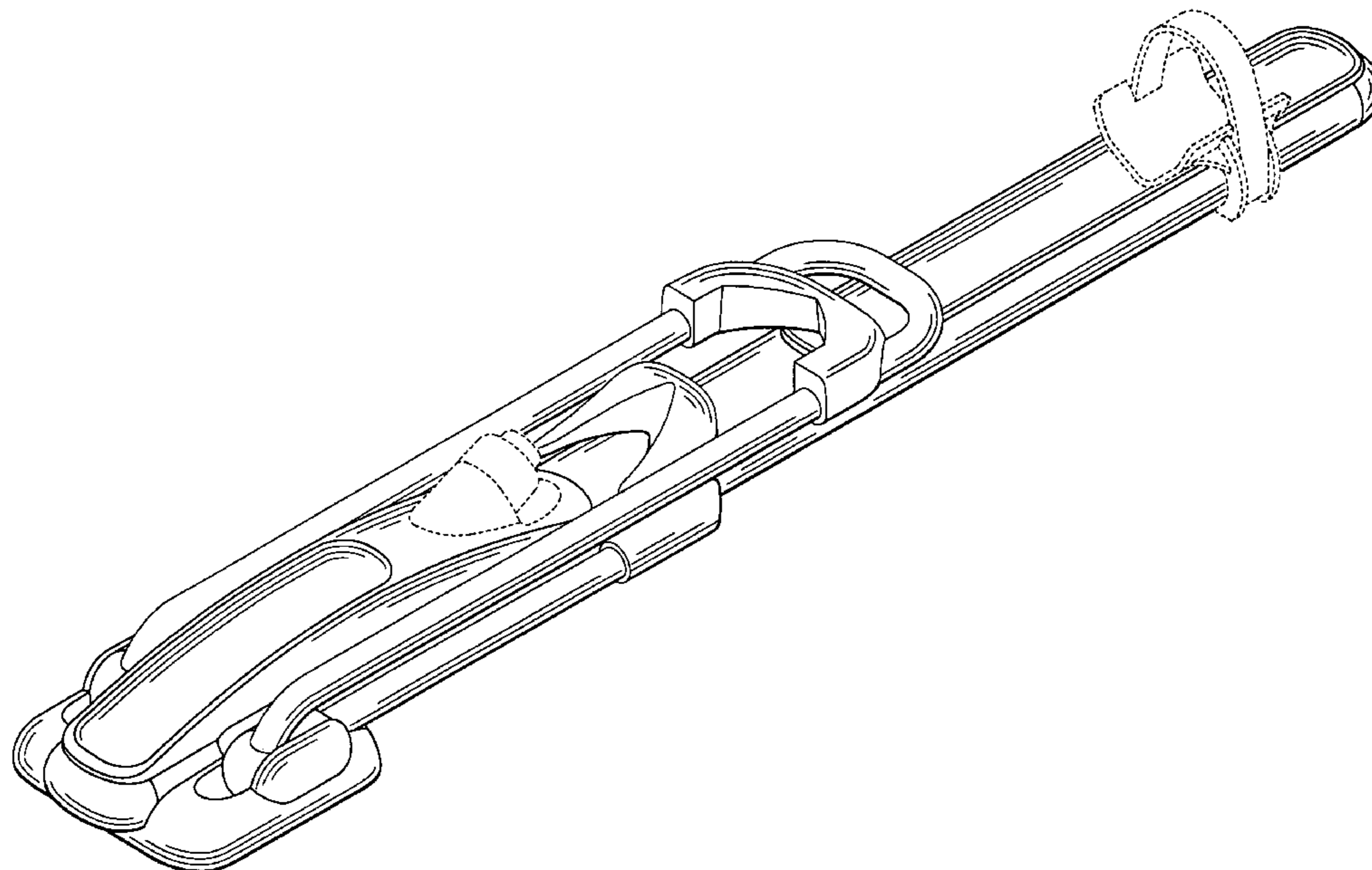

US D562,217 S

Page 2

U.S. PATENT DOCUMENTS

4,629,104 A	12/1986	Jacquet	5,549,231 A	8/1996	Fletcher
4,700,873 A	10/1987	Young	5,692,659 A	12/1997	Reeves
4,702,401 A	10/1987	Graber et al.	5,820,002 A	10/1998	Allen
4,875,608 A	10/1989	Graber	5,833,074 A	11/1998	Phillips
5,025,932 A	6/1991	Jay	5,862,966 A	1/1999	Mehls
5,042,705 A	8/1991	Johansson	5,944,198 A	8/1999	Ihalainen
5,052,605 A	10/1991	Johansson	5,988,403 A	11/1999	Robideau
5,169,044 A	12/1992	Englander	6,244,483 B1	6/2001	McLemore
5,230,449 A	7/1993	Collins	6,460,743 B2	10/2002	Edgerly
5,244,101 A	9/1993	Palmer	6,648,300 B2	11/2003	Chamoun
5,435,475 A	7/1995	Hudson	6,868,998 B2	3/2005	Dean
5,445,300 A	8/1995	Eipper			

* cited by examiner

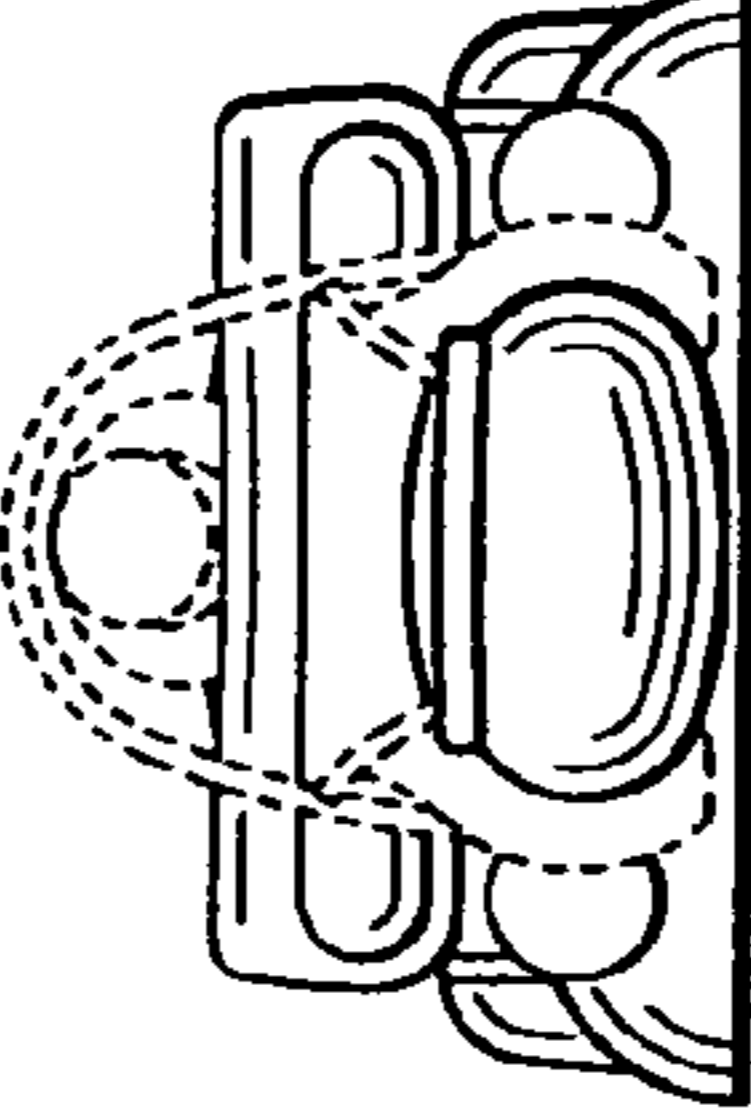
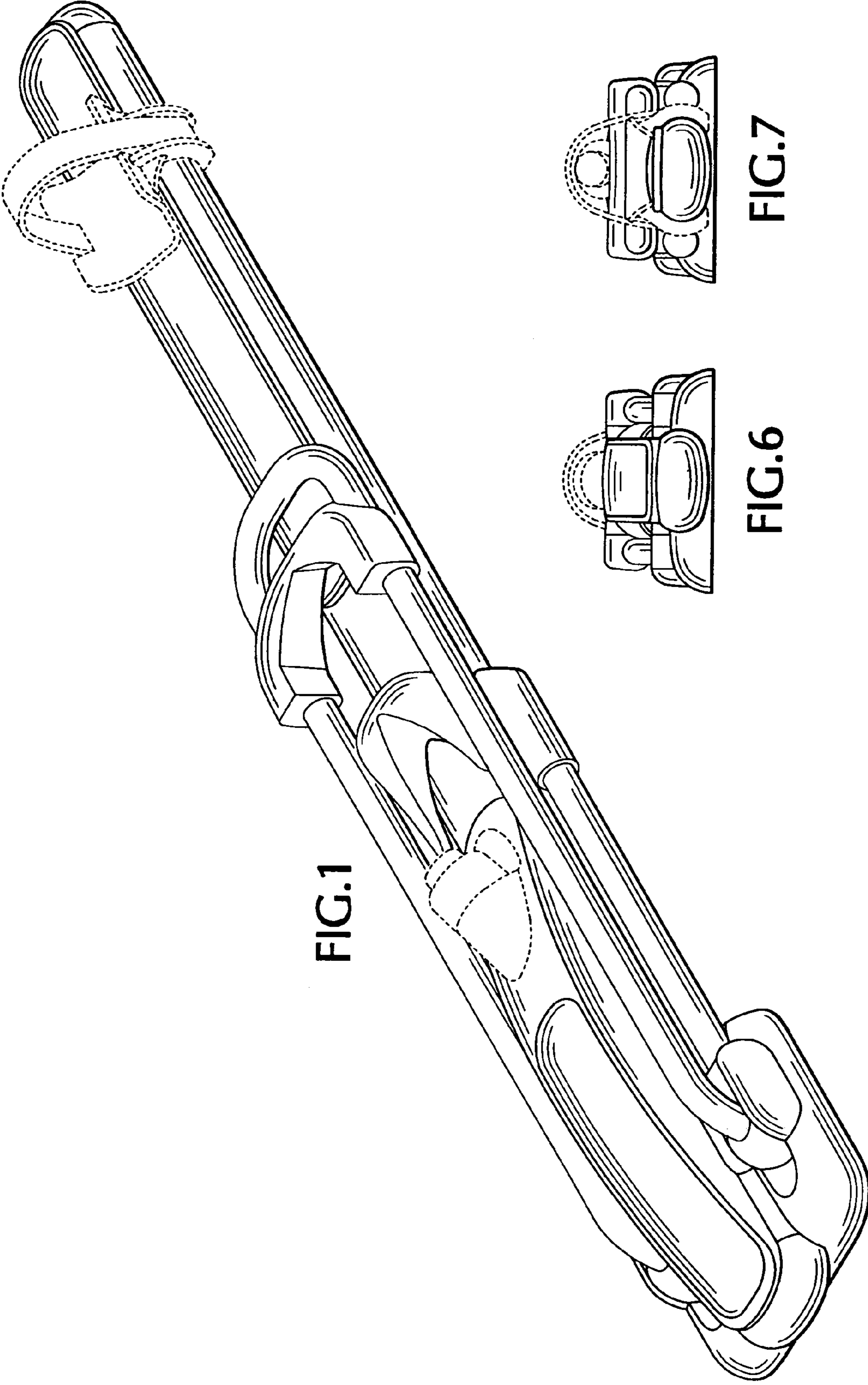

FIG. 7

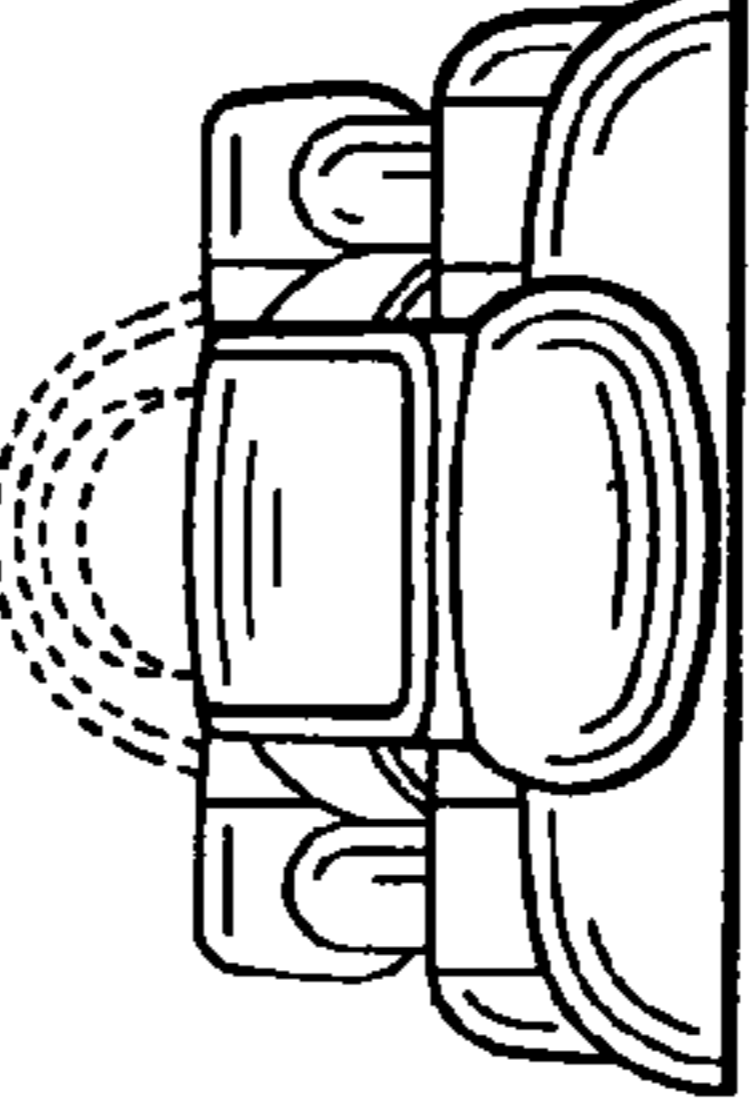

FIG. 6

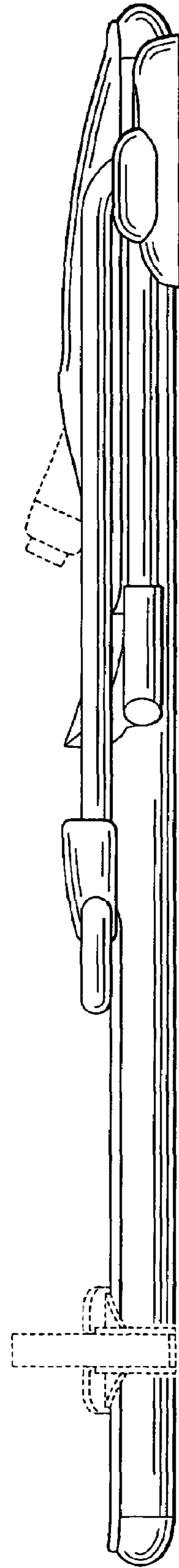
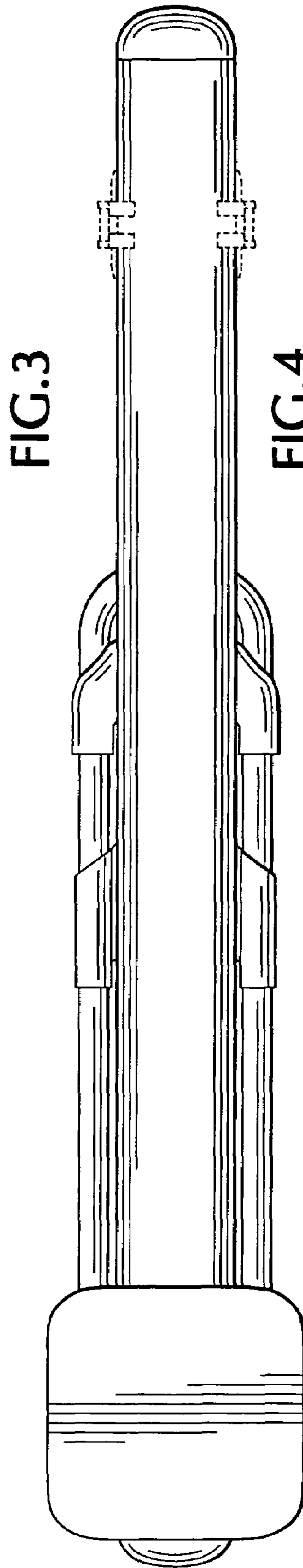
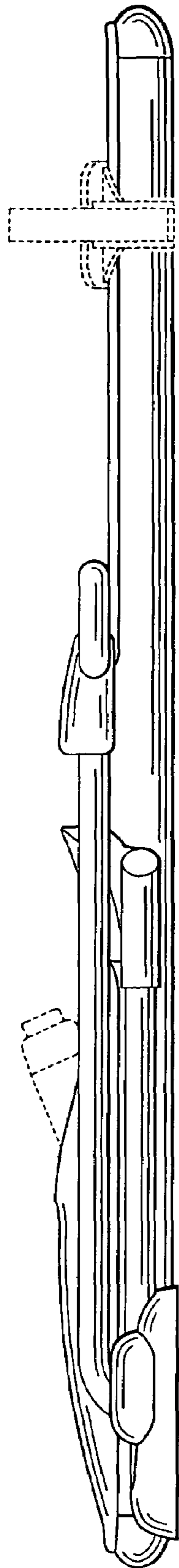
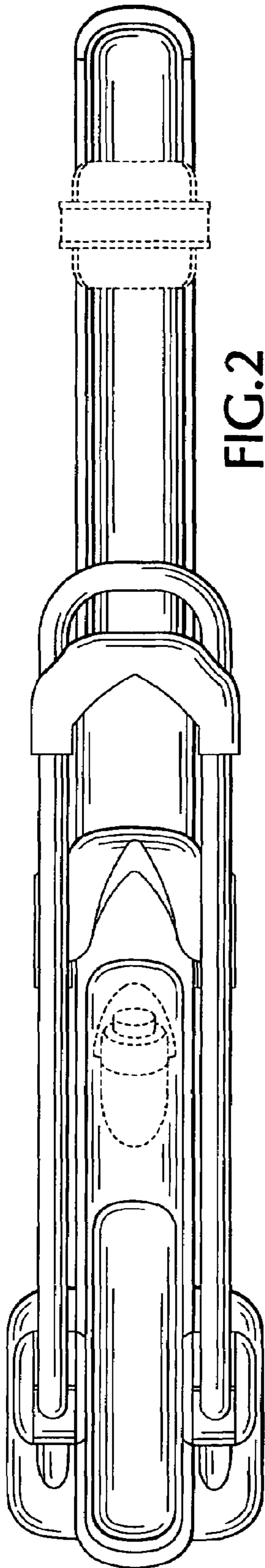

FIG. 2

FIG. 3

FIG. 4

FIG. 5