



US00D562044S

(12) **United States Design Patent**
Brown et al.

(10) **Patent No.: US D562,044 S**
(45) **Date of Patent: ** Feb. 19, 2008**

(54) **MERCHANDISE DISPLAY**

(75) Inventors: **Carrie Brown**, Hermosa Beach, CA (US); **Jason Giffin**, Gardena, CA (US)

(73) Assignee: **Belkin International, Inc.**, Compton, CA (US)

(**) Term: **14 Years**

(21) Appl. No.: **29/225,878**

(22) Filed: **Mar. 22, 2005**

(51) **LOC (8) Cl.** **06-99**

(52) **U.S. Cl.** **D6/553**

(58) **Field of Classification Search** D6/396,
D6/402, 449, 467, 470, 471, 475, 509, 512,
D6/553, 567, 572, 573-4, 635; D20/10,
D20/19, 42-3; 40/508, 661.08; 108/42;
206/459.5, 775, 779; 211/13.1, 59.2, 85.26,
211/88.01; 248/176.1

See application file for complete search history.

(56) **References Cited**

U.S. PATENT DOCUMENTS

D278,109 S *	3/1985	Leeds	D6/419
D304,000 S *	10/1989	Turbeville	D6/310
D306,179 S *	2/1990	Friedman	D20/43
D368,184 S *	3/1996	Eley	D6/449
D391,296 S *	2/1998	Hill, Sr.	D19/90
5,878,982 A *	3/1999	Cumby et al.	248/27.8
6,484,429 B1 *	11/2002	Przylucki	40/661.08
D488,627 S *	4/2004	Stravitz	D6/314
D532,219 S *	11/2006	Sandler et al.	D6/475
D542,582 S *	5/2007	Stafford et al.	D6/553

* cited by examiner

Primary Examiner—Cathron Brooks
Assistant Examiner—Angela J Lee
(74) *Attorney, Agent, or Firm*—Bryan Cave LLP

(57) **CLAIM**

We claim the ornamental design for the merchandise display, as shown and described.

DESCRIPTION

FIG. 1 is a front perspective view of the merchandise display showing our design;

FIG. 2 is a front view of the merchandise display design of FIG. 1;

FIG. 3 is a rear perspective view of the merchandise display of FIG. 1;

FIG. 4 is a left side view of the merchandise display design of FIG. 1 where the right side view is a mirror image of the left side view;

FIG. 5 is a top view of the merchandise display design of FIG. 1;

FIG. 6 is a bottom view of the merchandise display design of FIG. 1; and,

FIG. 7 is a rear view of the merchandise display design of FIG. 1.

The broken line showing of features of the merchandise display is included for the purpose of illustrating portions of the article and forms no part of the claimed design.

1 Claim, 7 Drawing Sheets

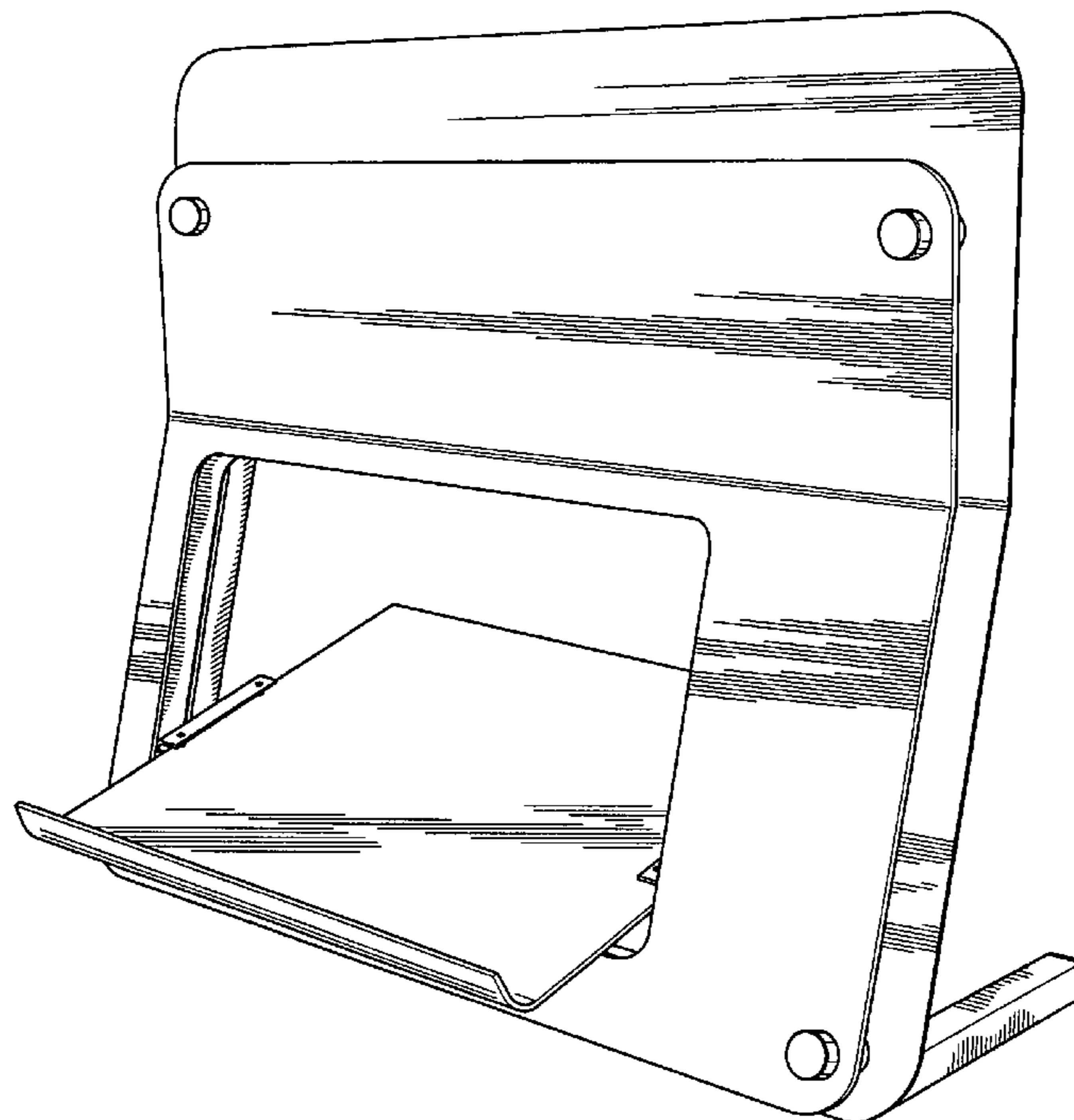

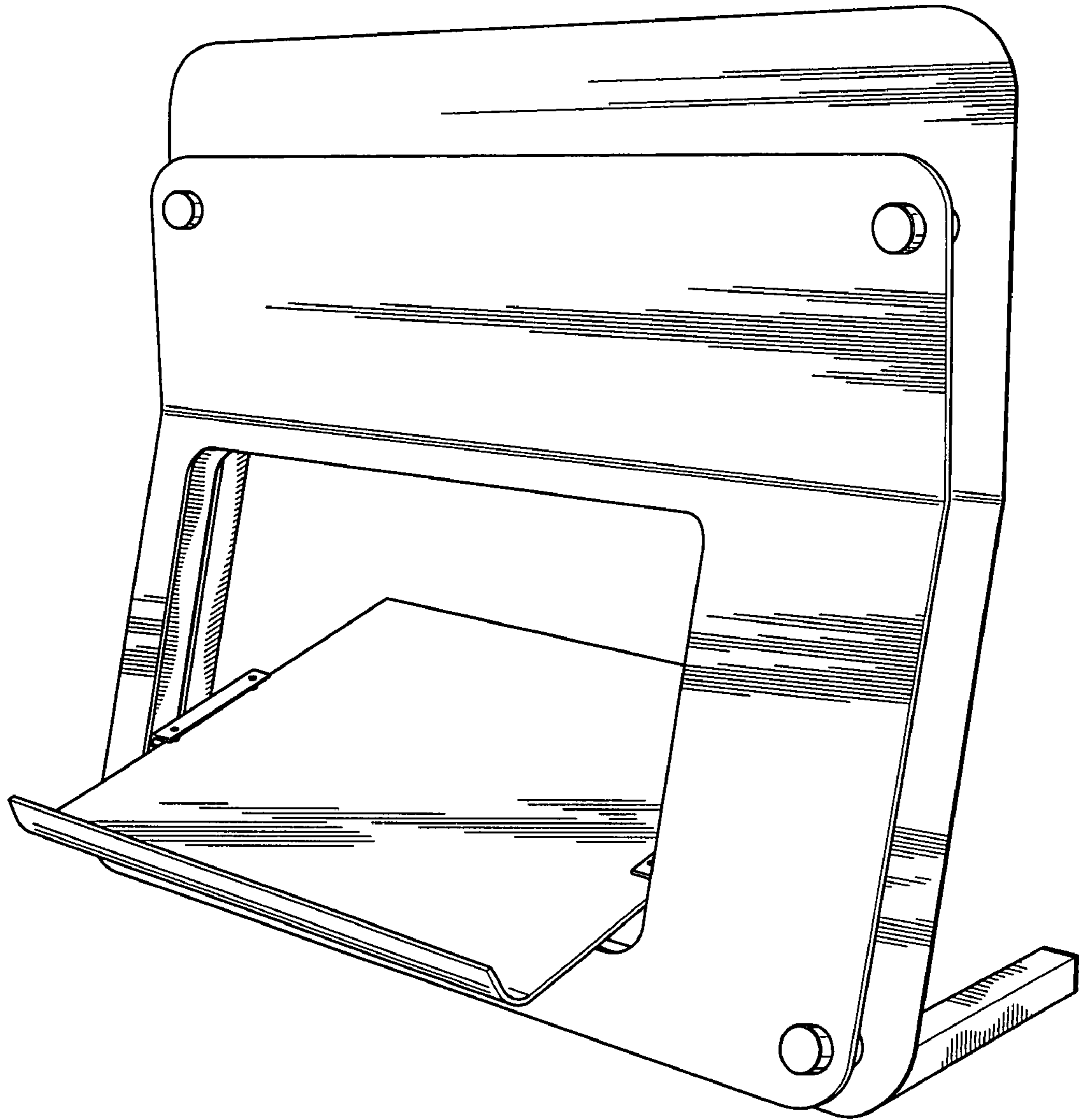

FIG. 1

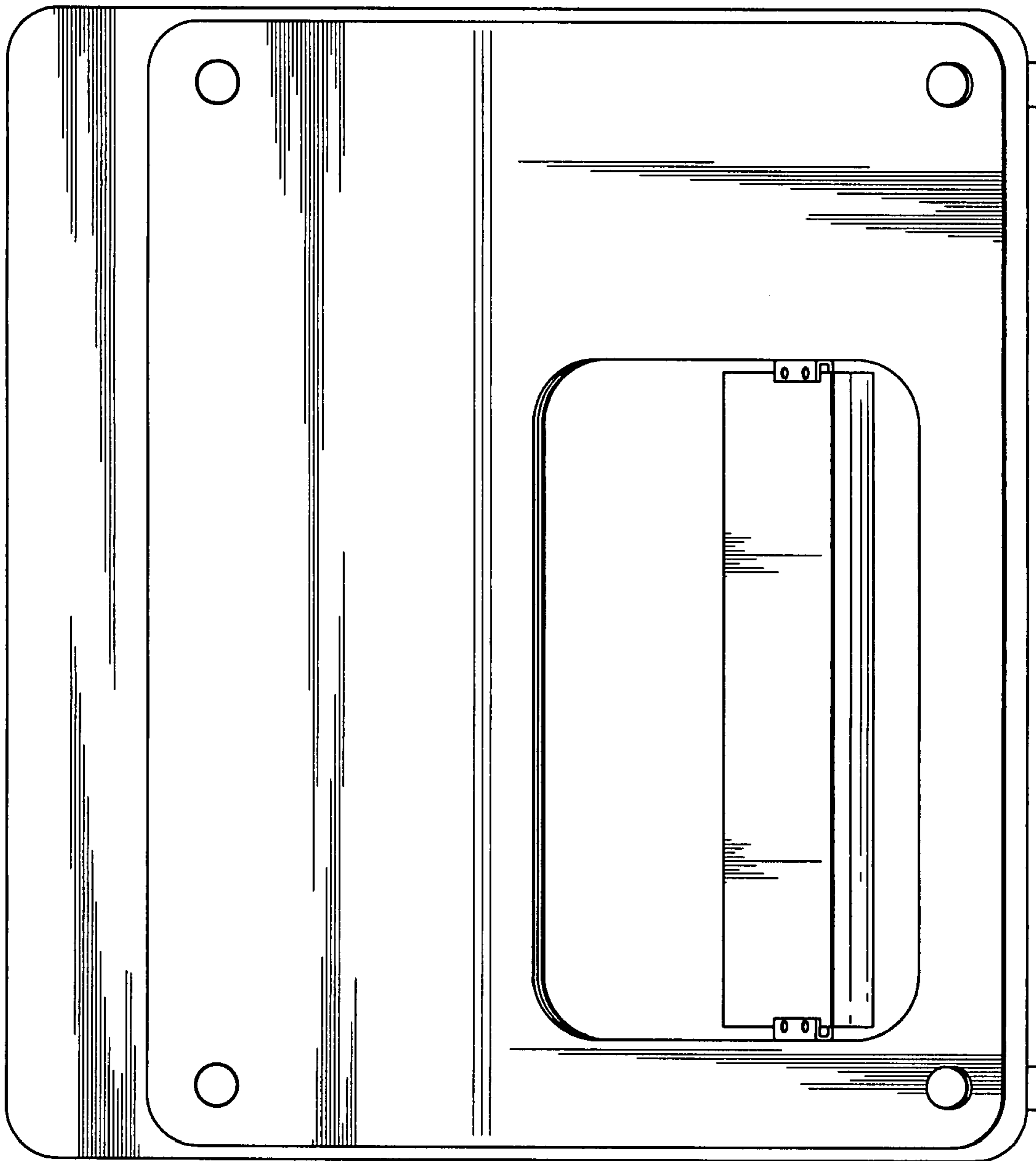

FIG. 2

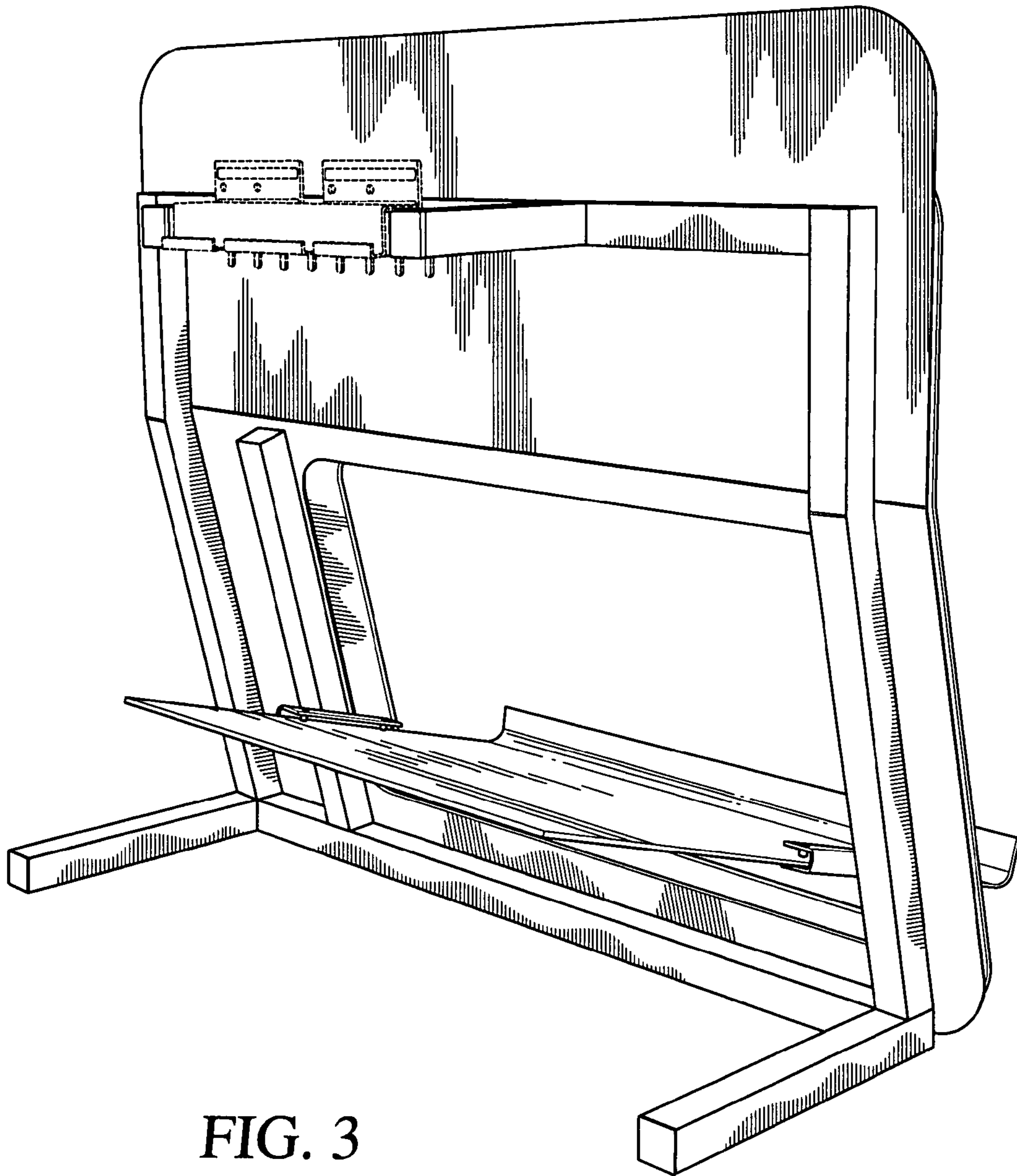

FIG. 3

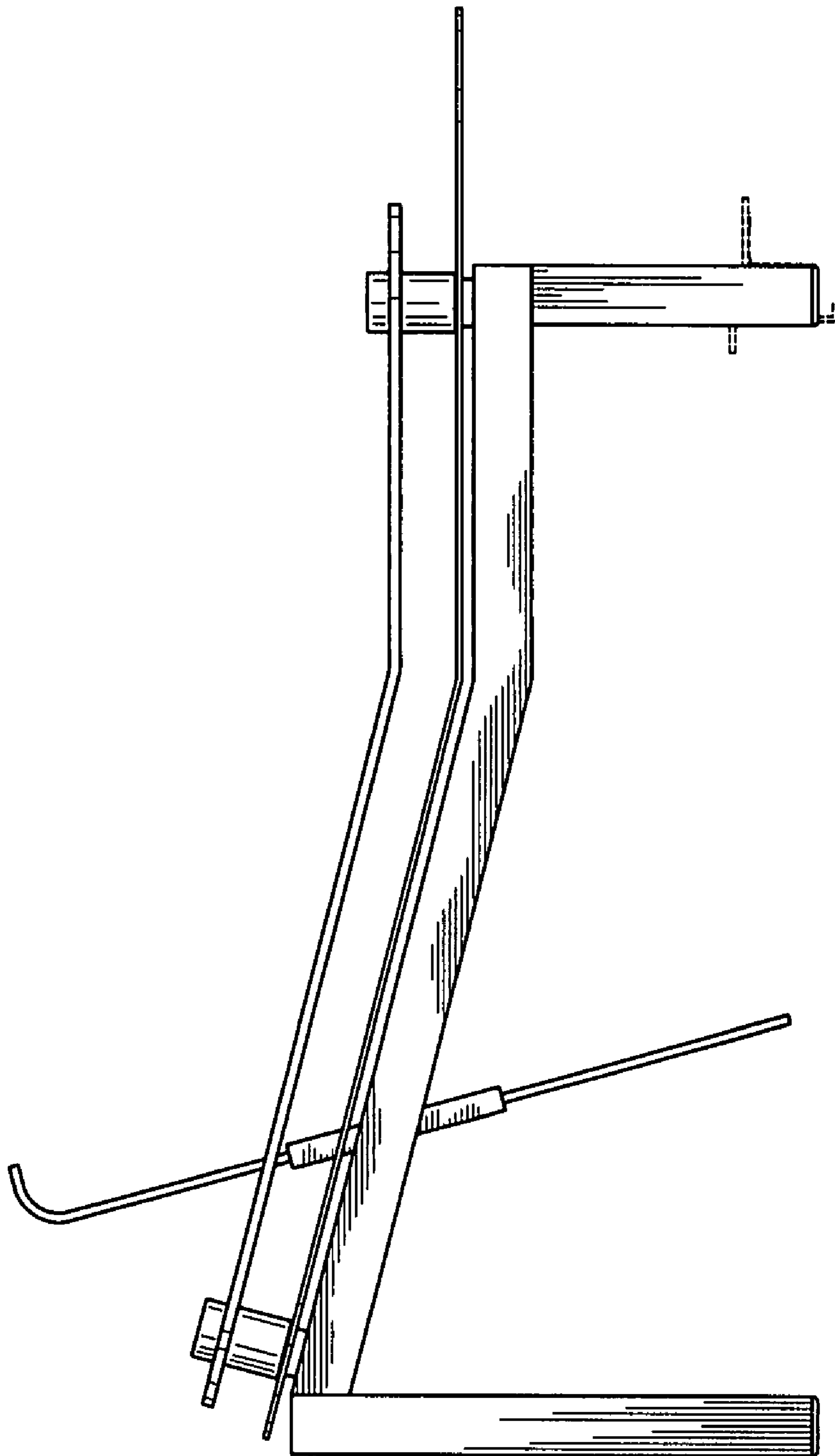

FIG. 4

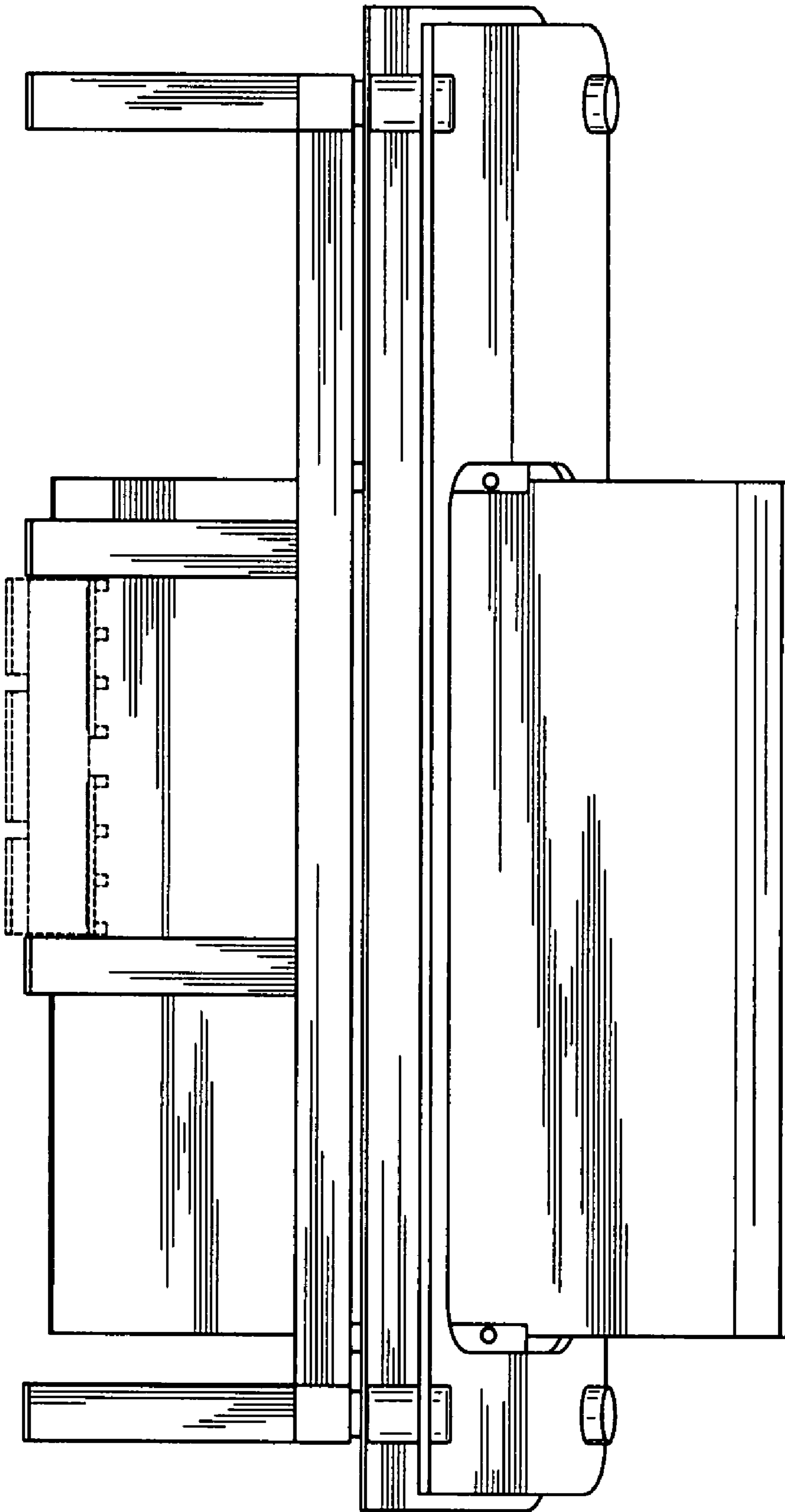
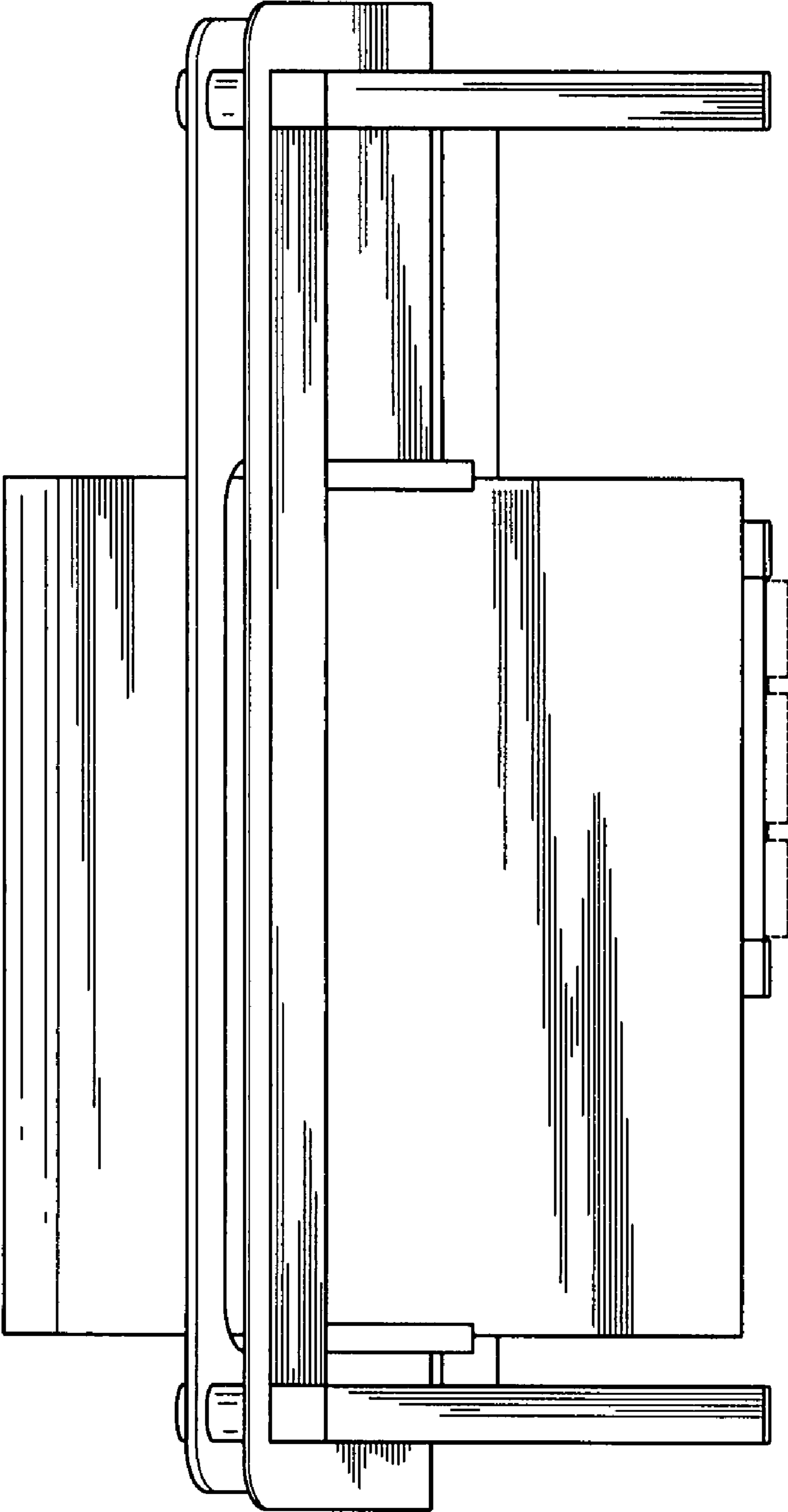

FIG. 5

FIG. 6



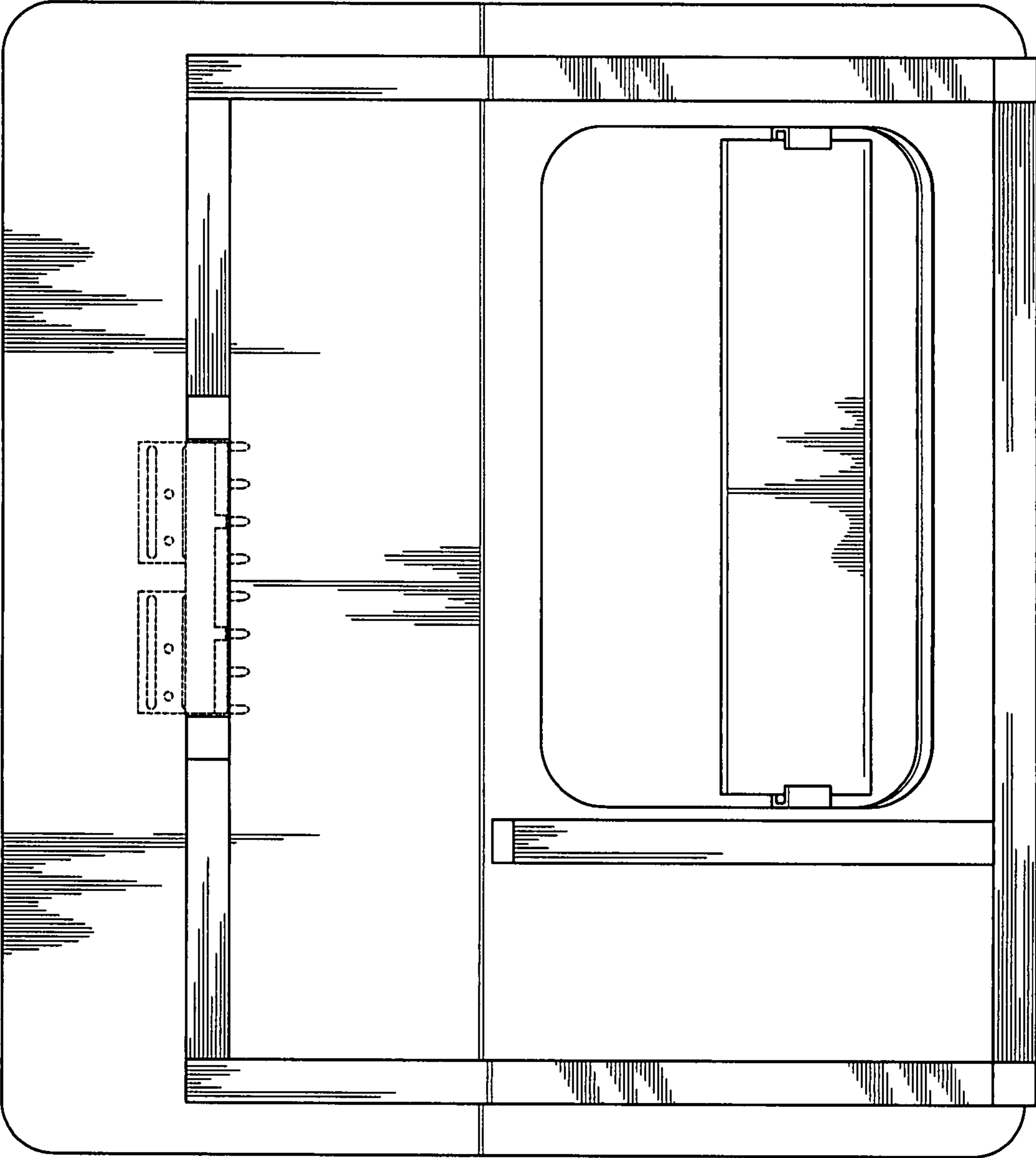

FIG. 7