



US00D561975S

(12) **United States Design Patent** (10) **Patent No.:** **US D561,975 S**
Thompson et al. (45) **Date of Patent:** **** Feb. 12, 2008**

(54) **POSTAL RECEPTACLE**

(75) Inventors: **David Thompson**, St. Charles, IL (US);
Rayanne S. Thompson, St. Charles, IL (US)

(73) Assignee: **David C. Thompson**, St. Charles, IL (US)

(**) Term: **14 Years**

(21) Appl. No.: **29/276,539**

(22) Filed: **Jan. 29, 2007**

Related U.S. Application Data

(63) Continuation of application No. 10/704,124, filed on Nov. 10, 2003, now Pat. No. 7,168,611.

(51) **LOC (8) Cl.** **99-00**

(52) **U.S. Cl.** **D99/30**

(58) **Field of Classification Search** D99/28-29, D99/30, 43; D25/48, 59, 60, 129, 145; 52/210-211, 52/311.2-312, 309.8, 316, 36.3, 217; 232/17, 232/19, 38, 39, 45; 108/152; 126/500; 428/28
See application file for complete search history.

(56) **References Cited**

U.S. PATENT DOCUMENTS

- 827,369 A * 7/1906 Holbein et al. 52/36.3
- D110,454 S * 7/1938 Baum D25/60
- D166,749 S 5/1952 Heinz
- D199,043 S 9/1964 Duncan et al.
- 3,657,848 A * 4/1972 Davidson 52/36.3
- 3,778,945 A * 12/1973 Medow 52/217
- D256,287 S 8/1980 McConnell
- 4,359,185 A 11/1982 Castro
- D291,937 S 9/1987 Fisher
- D296,602 S 7/1988 Klein
- D308,124 S 5/1990 Janzer
- D312,912 S 12/1990 Klahre
- D322,418 S 12/1991 White
- D331,481 S 12/1992 Barlow
- 5,465,540 A * 11/1995 Biernazki 52/211

- D422,773 S 4/2000 Klein
- 6,725,614 B2 * 4/2004 Schiedegger et al. 52/211
- D493,269 S 7/2004 Burgos et al.
- D503,843 S * 4/2005 Murphy et al. D99/30
- 7,168,611 B2 * 1/2007 Thompson et al. 232/38

* cited by examiner

Primary Examiner—Paula A. Greene

(74) *Attorney, Agent, or Firm*—Nixon & Vanderhye, P.C.

(57) **CLAIM**

The ornamental design for a postal receptacle, as shown and described.

DESCRIPTION

FIG. 1 is a front view of an embodiment of a postal receptacle assembly;

FIG. 2 is a top perspective view of the postal receptacle assembly of FIG. 1;

FIG. 3 is a left side view of the postal receptacle assembly of FIG. 1, the right side view being a mirror image of the left side view;

FIG. 4 is a top view of the postal receptacle assembly of FIG. 1;

FIG. 5 is a bottom view of the postal receptacle assembly of FIG. 1;

FIG. 6 is a back view of the postal receptacle assembly of FIG. 1;

FIG. 7 is a front view of a second embodiment of a postal receptacle assembly;

FIG. 8 is a top perspective view of a postal receptacle thereof;

FIG. 9 is a left side view of a postal receptacle assembly, the right side view being a mirror image of the left side view;

FIG. 10 is a top view thereof;

FIG. 11 is a bottom view thereof; and,

FIG. 12 is a back view thereof.

1 Claim, 10 Drawing Sheets

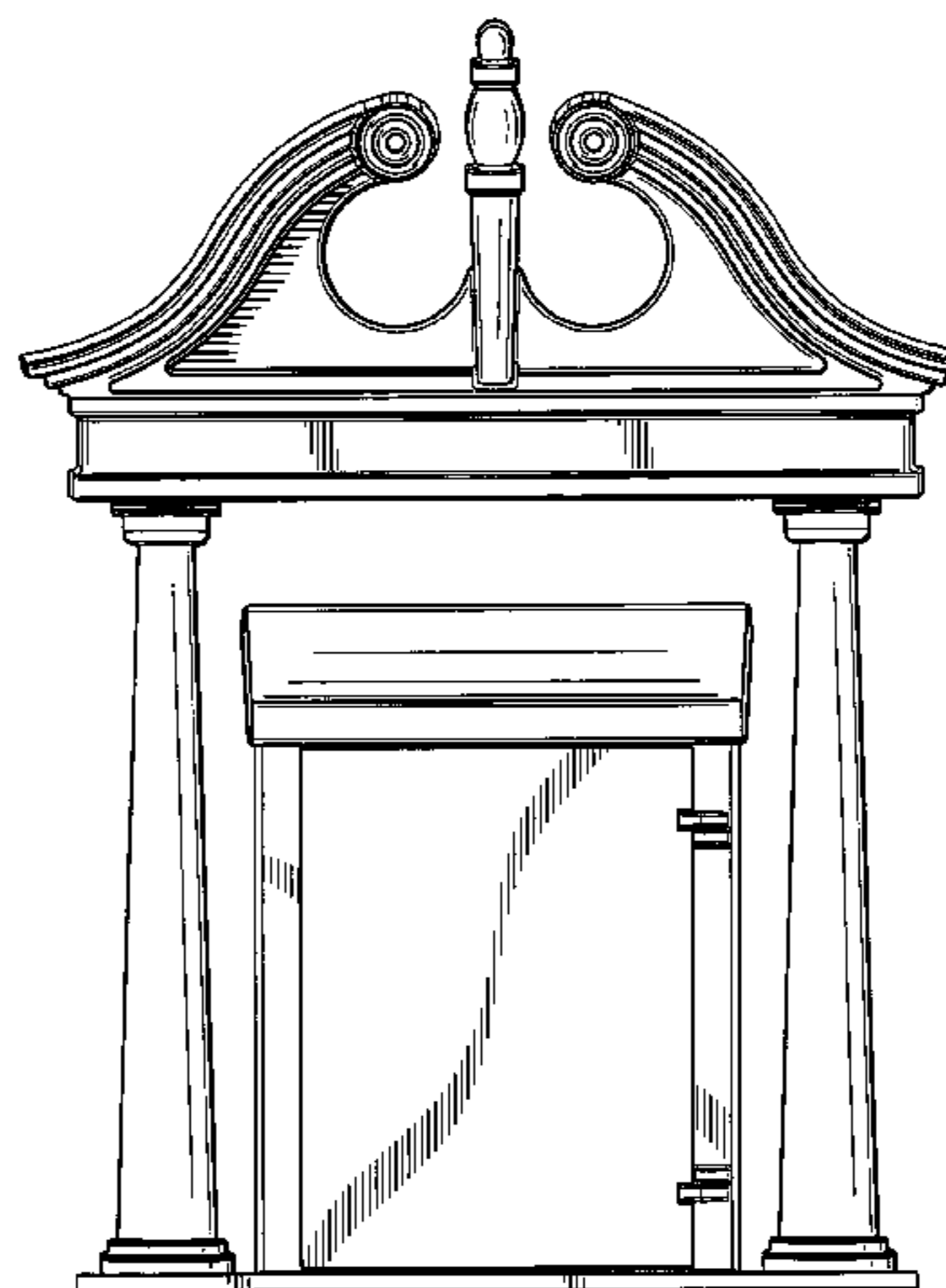
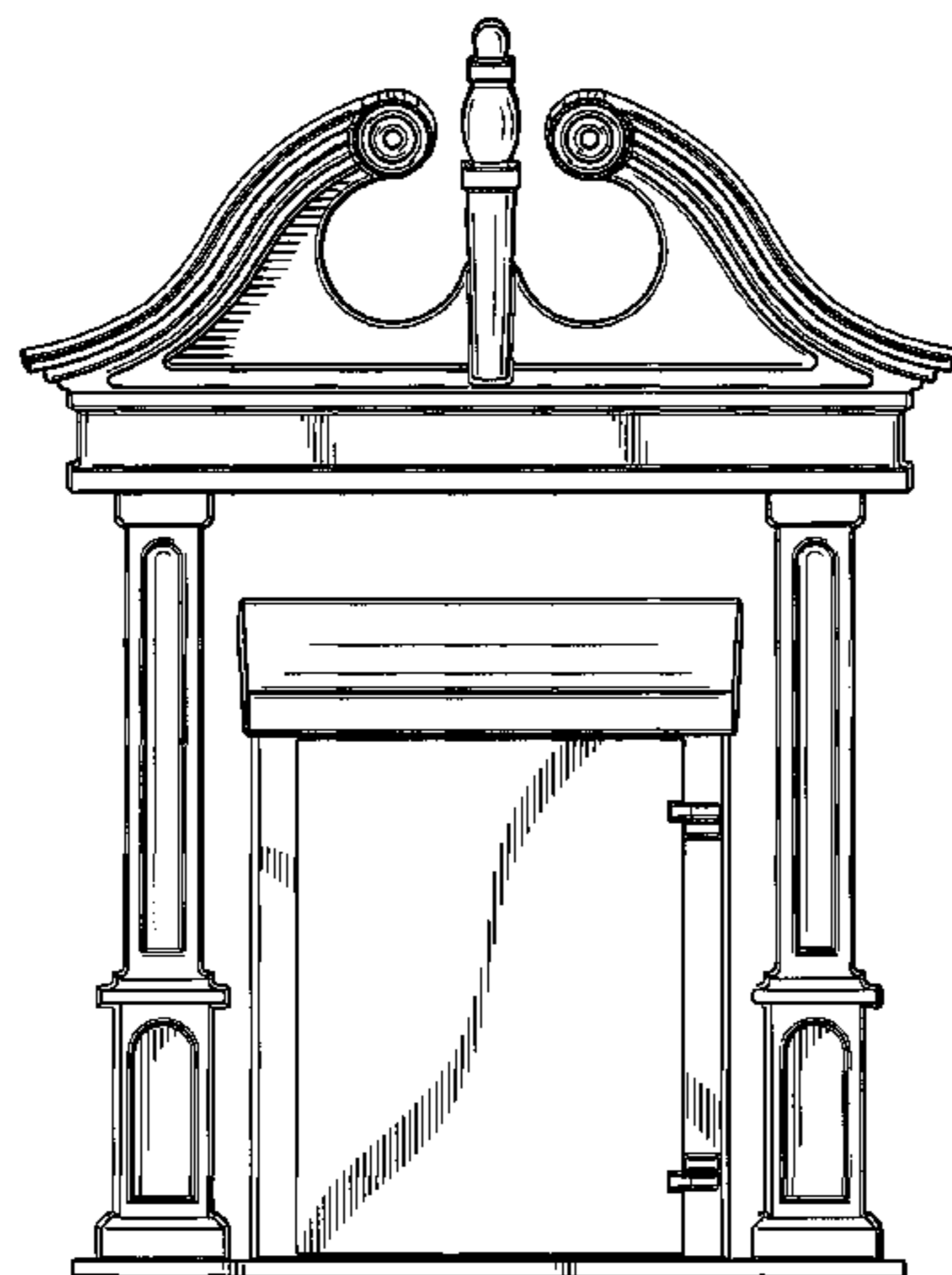

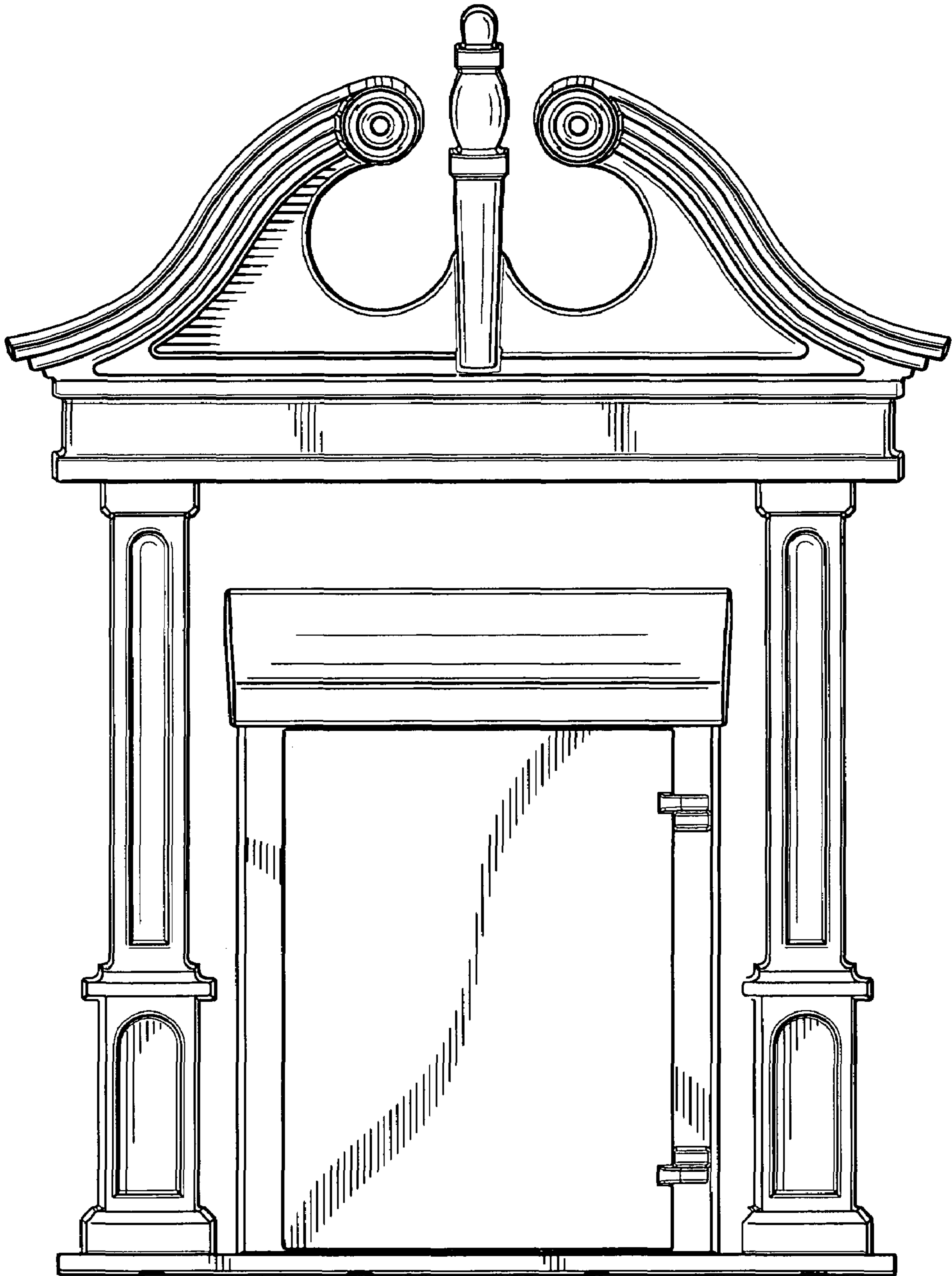

Fig. 1

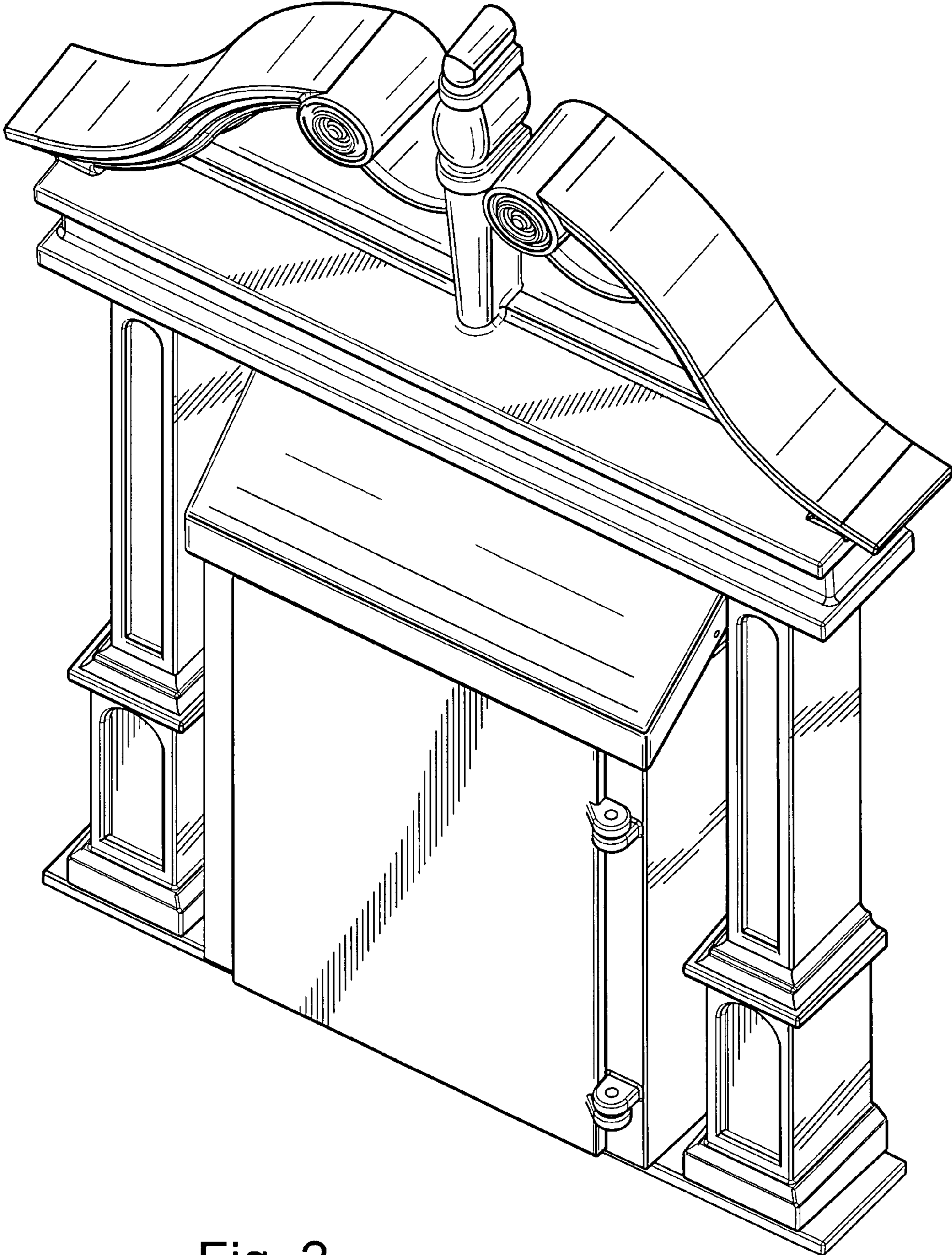

Fig. 2

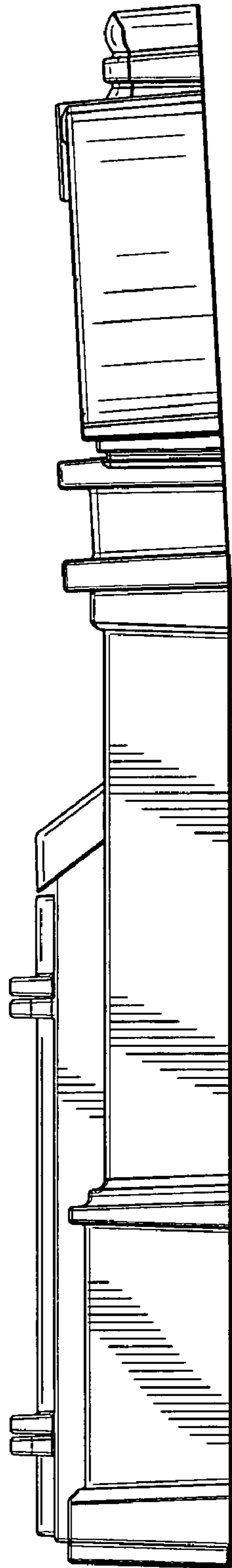

Fig. 3

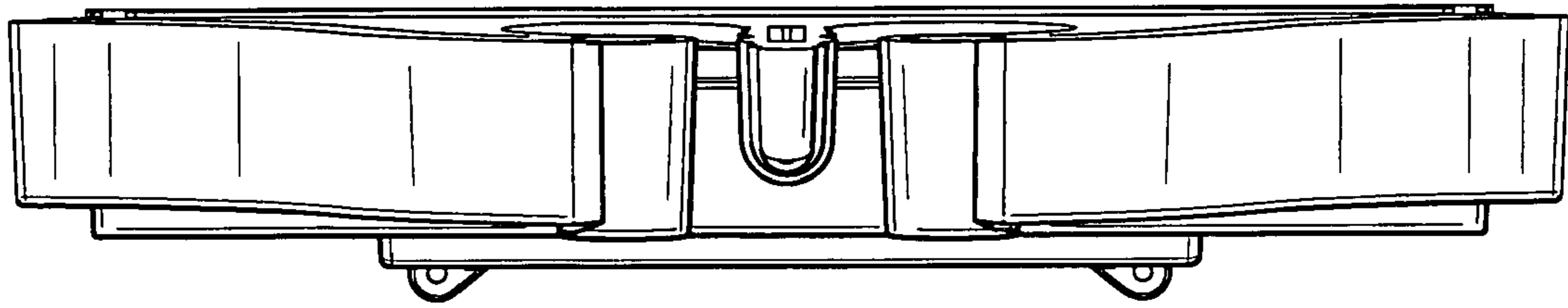

Fig. 4

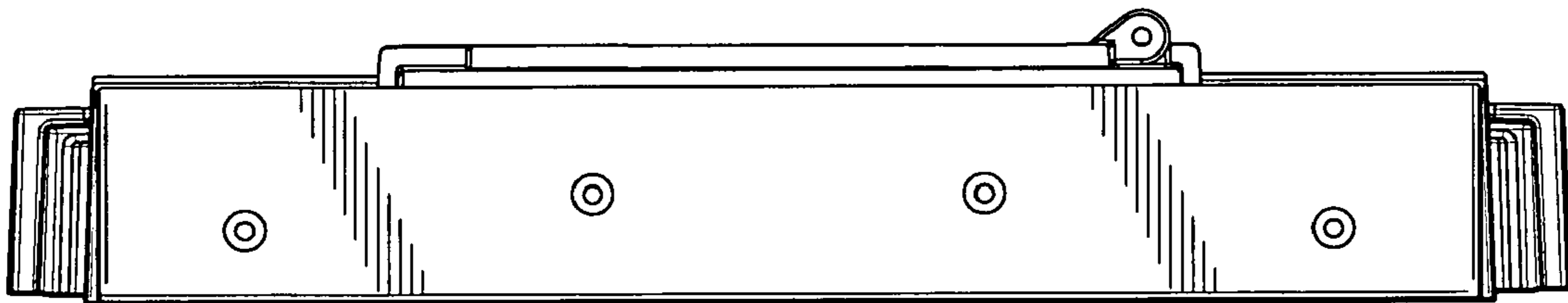

Fig. 5

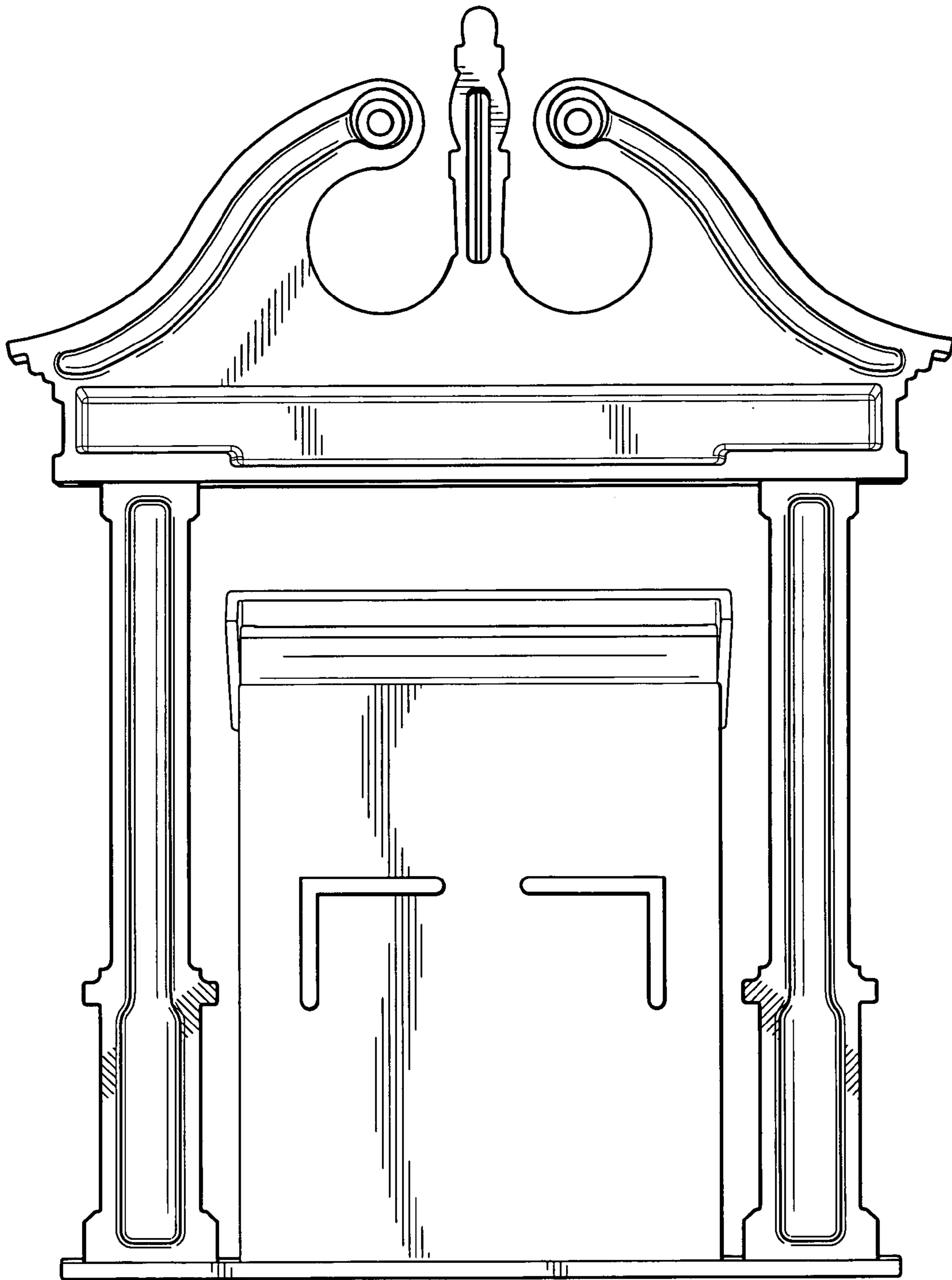

Fig. 6

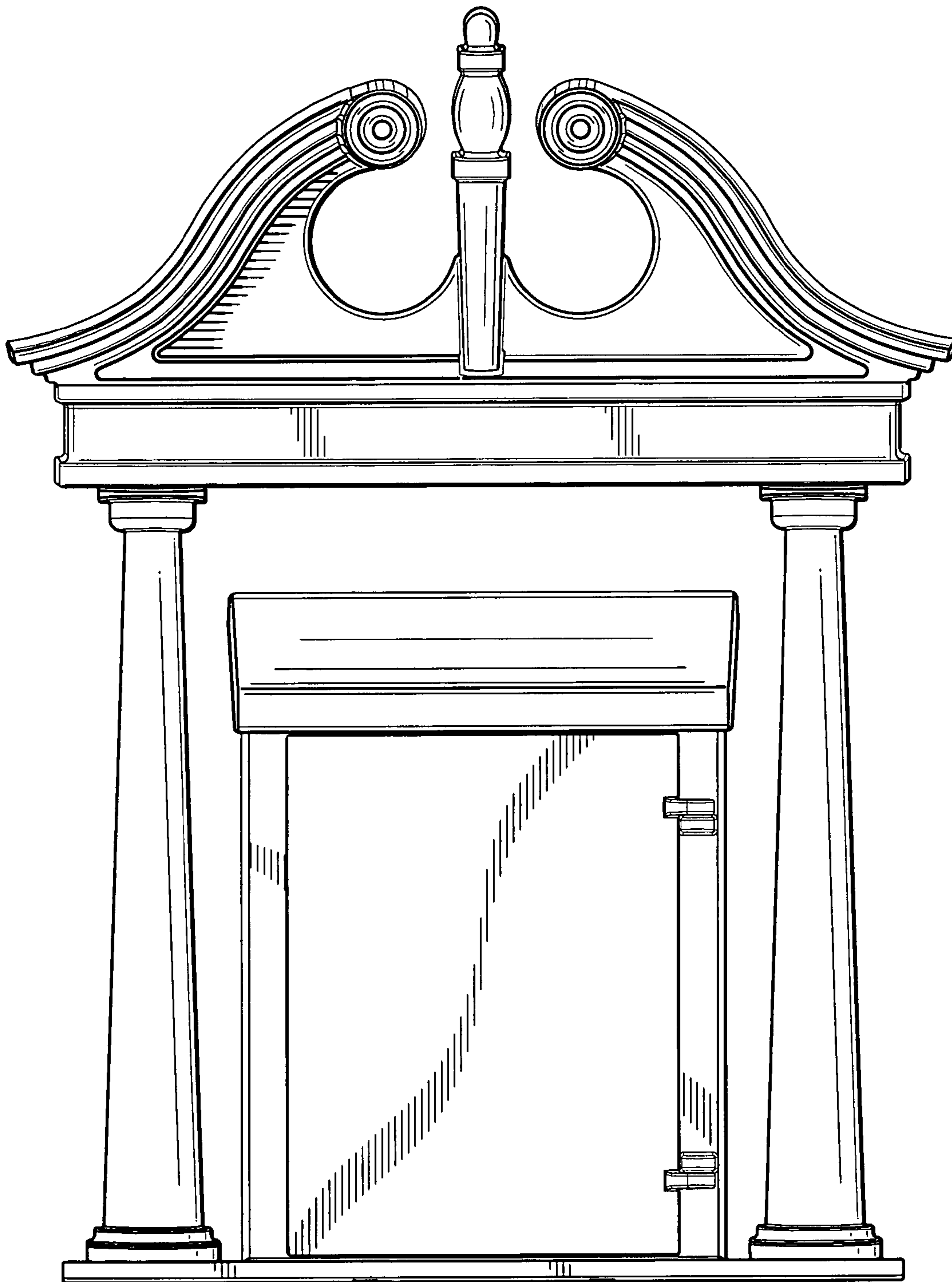

Fig. 7

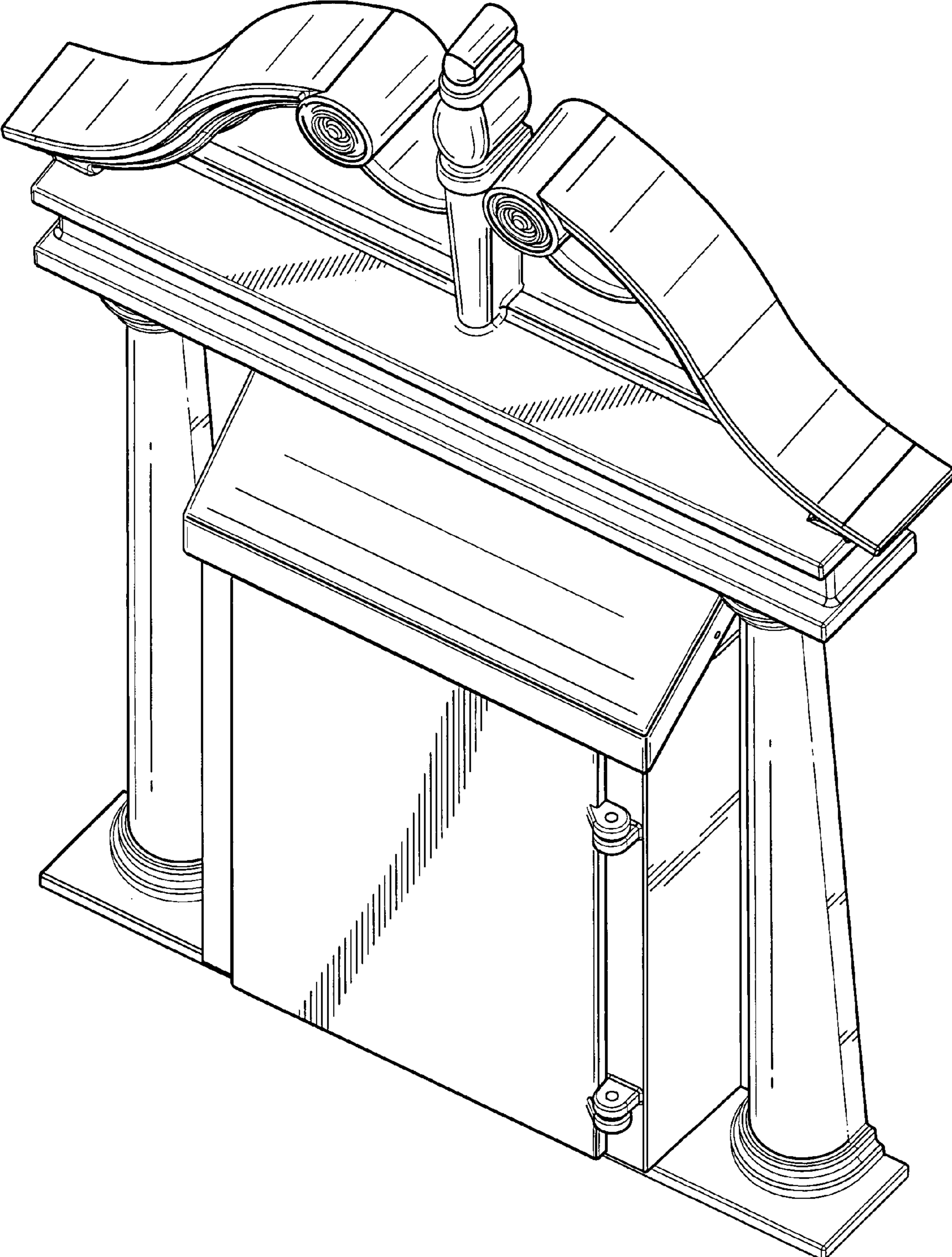

Fig. 8

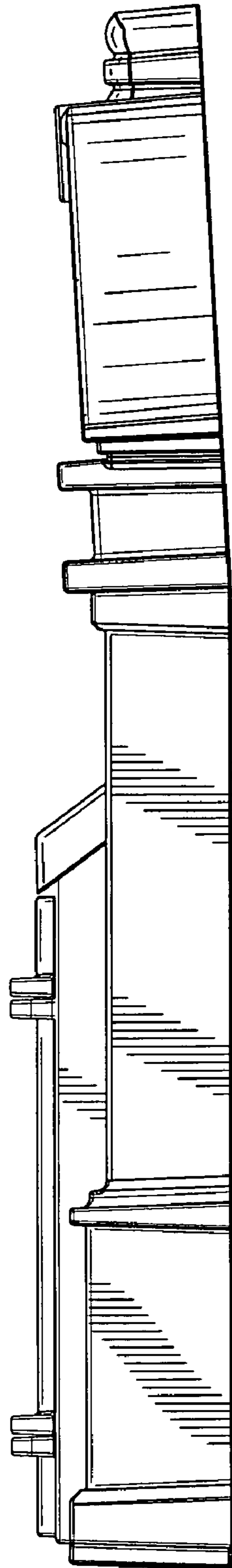

Fig. 9

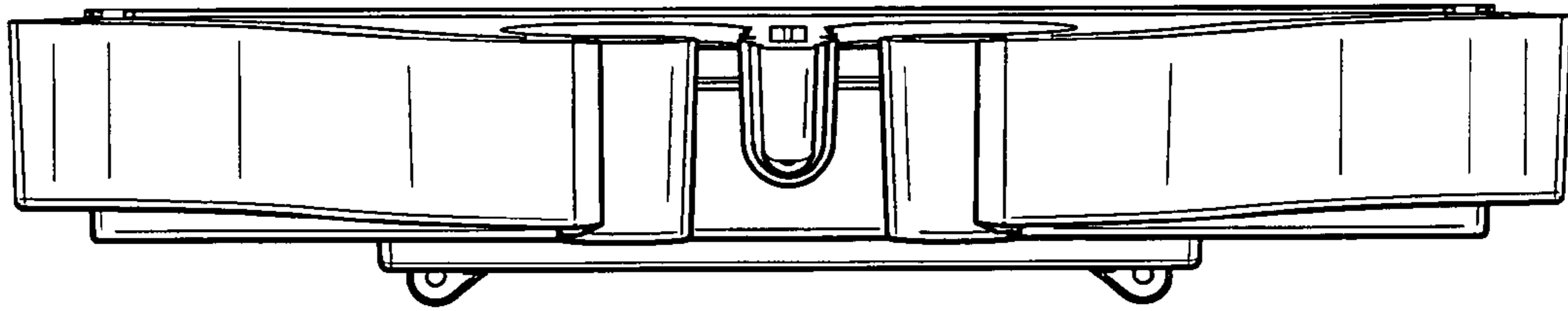

Fig. 10

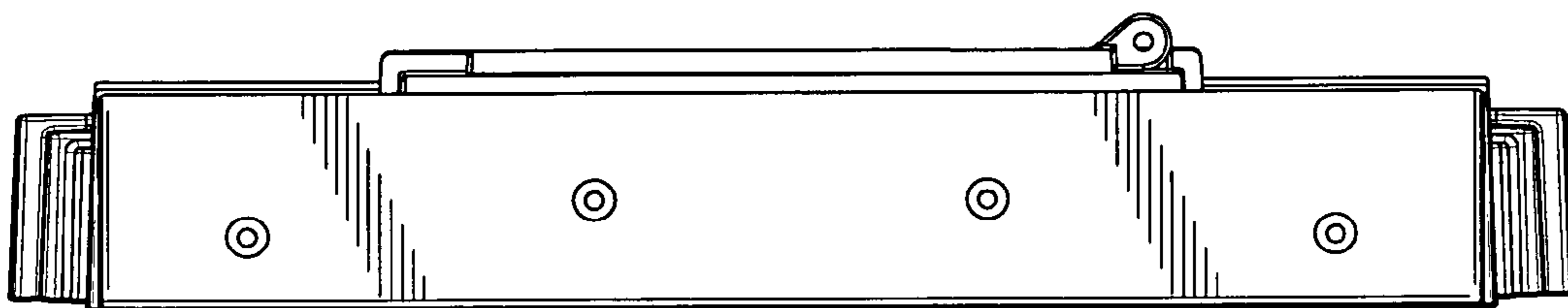

Fig. 11

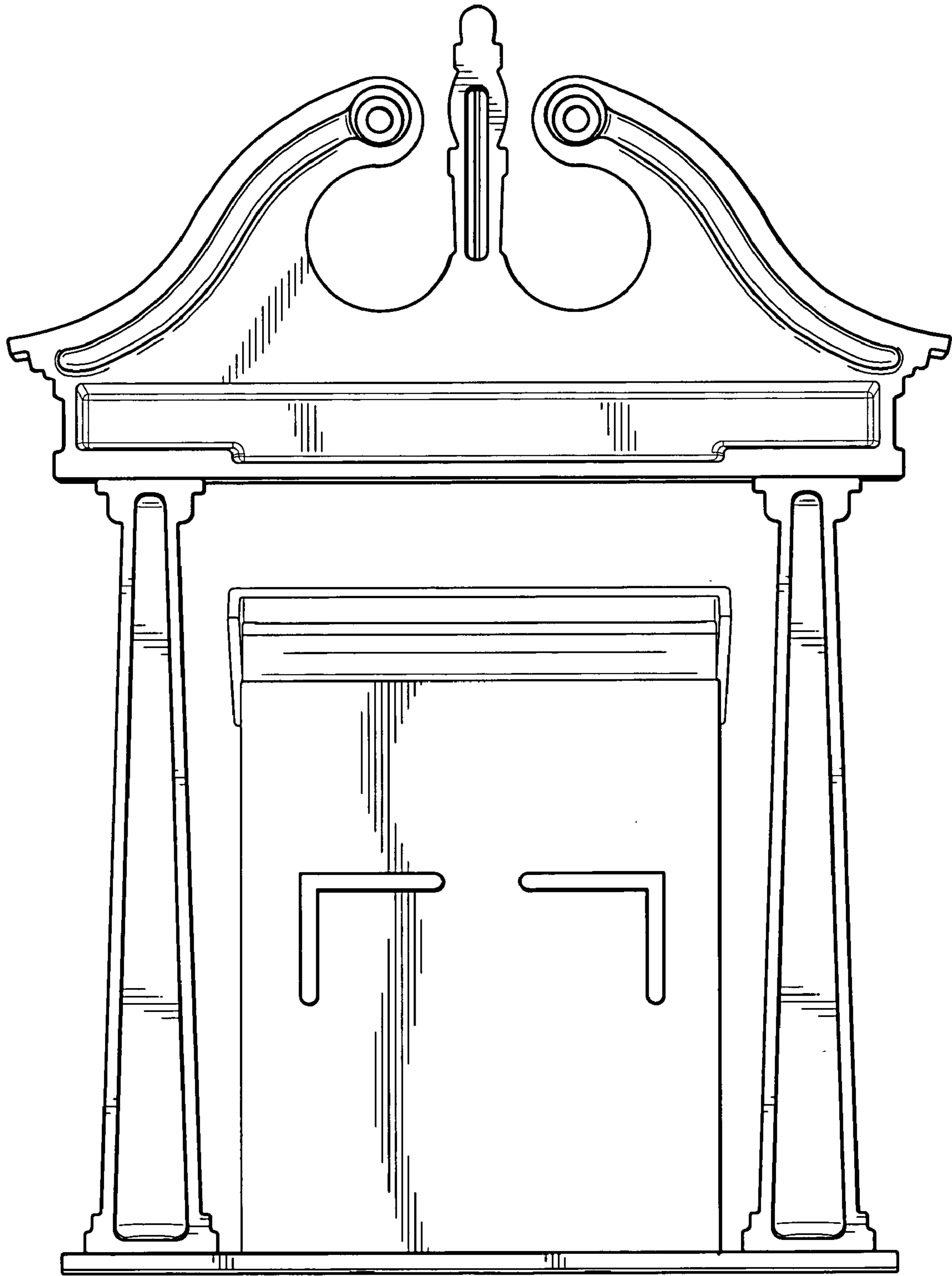

Fig. 12