



US00D561972S

(12) **United States Design Patent**
Roever

(10) **Patent No.:** **US D561,972 S**

(45) **Date of Patent:** **** Feb. 12, 2008**

(54) **KNOCKDOWN CART**

(75) Inventor: **Peter Roever**, West Bend, WI (US)

(73) Assignee: **The Vollrath Company, L.L.C.**,
Sheboygan, WI (US)

(**) Term: **14 Years**

(21) Appl. No.: **29/271,551**

(22) Filed: **Jan. 22, 2007**

(51) **LOC (8) Cl.** **12-02**

(52) **U.S. Cl.** **D34/17**

(58) **Field of Classification Search** D34/12-27;
280/47.34, 47.35, 79.11, 79.2, 79.3

See application file for complete search history.

(56) **References Cited**

U.S. PATENT DOCUMENTS

D199,670	S	*	12/1964	Inglis	D34/21
4,644,876	A	*	2/1987	Thomas	108/192
4,740,010	A	*	4/1988	Moskovitz	280/641
4,763,799	A	*	8/1988	Cohn et al.	211/187
D304,111	S	*	10/1989	Mehalick	D34/18
4,998,023	A	*	3/1991	Kitts	280/47.35
D362,528	S	*	9/1995	Shannon et al.	D34/21
D363,590	S	*	10/1995	Kazmerchek et al.	D34/21
5,653,457	A	*	8/1997	Marmer et al.	280/30
D425,280	S	*	5/2000	vom Braucke et al.	D34/21
D436,239	S	*	1/2001	Walsh	D34/21
D445,229	S	*	7/2001	Stravitz et al.	D34/17
D455,881	S	*	4/2002	Arvans	D34/21

* cited by examiner

Primary Examiner—Cynthia E Ramirez

(74) *Attorney, Agent, or Firm*—Foley & Lardner LLP

(57) **CLAIM**

The ornamental design for a knockdown cart, as shown and described.

DESCRIPTION

FIG. 1 is an isometric view of the knockdown cart showing my new design;

FIG. 2 is a front elevational view thereof;

FIG. 3 is a top plan view thereof;

FIG. 4 is a rear elevational view thereof;

FIG. 5 is a right side elevational view thereof;

FIG. 6 is a left side elevational view thereof;

FIG. 7 is a bottom plan view thereof;

FIG. 8 is an exploded view thereof;

FIG. 9 is another isometric view thereof;

FIG. 10 is another front elevational view thereof;

FIG. 11 is another top plan view thereof;

FIG. 12 is another rear elevational view thereof;

FIG. 13 is another right side elevational view thereof;

FIG. 14 is another left side elevational view thereof; and,

FIG. 15 is another bottom plan view thereof.

The broken lines in FIGS. 1 through 7 are included for the purpose of illustrating environment and form no part of the claimed design.

1 Claim, 11 Drawing Sheets

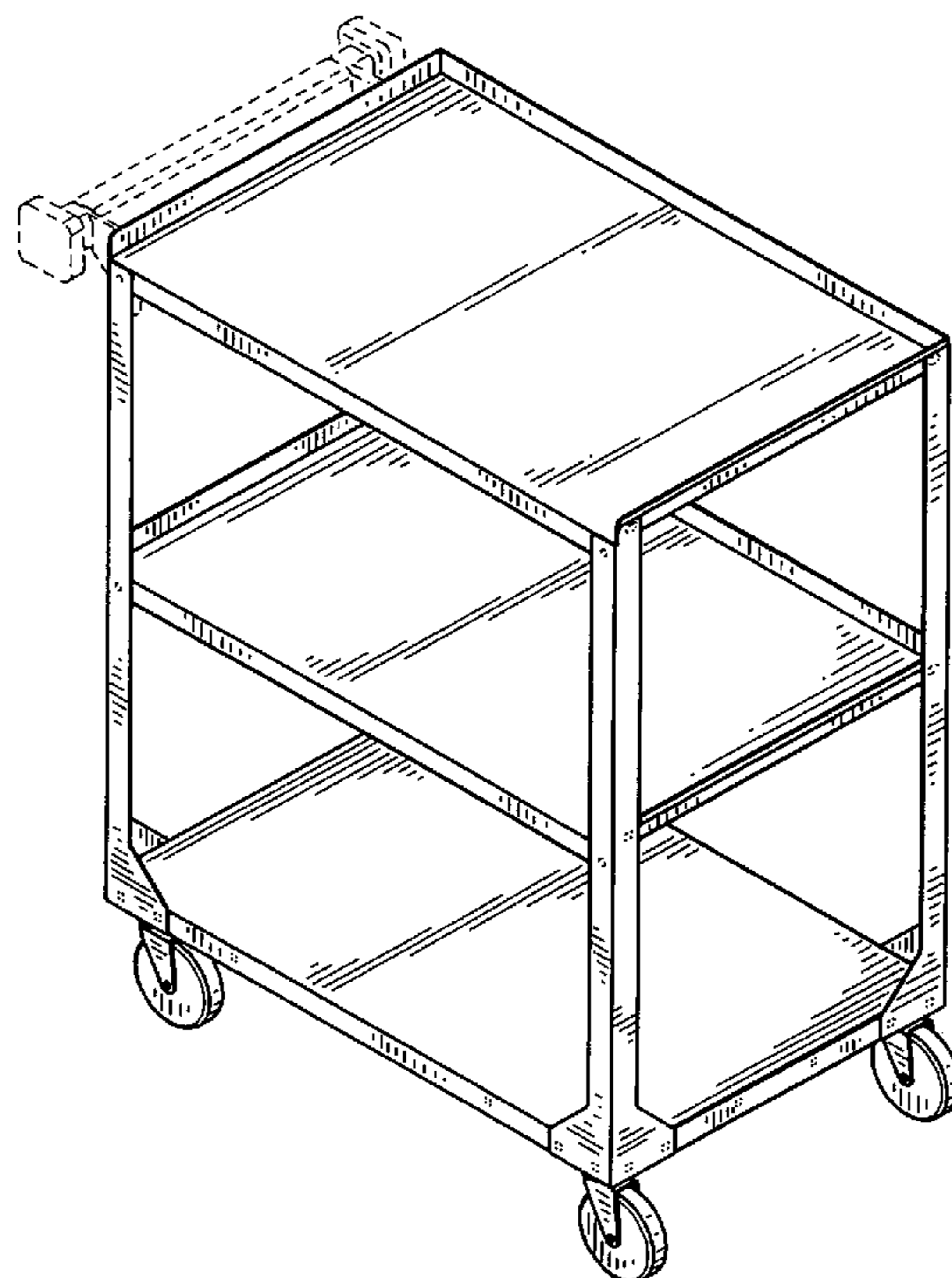

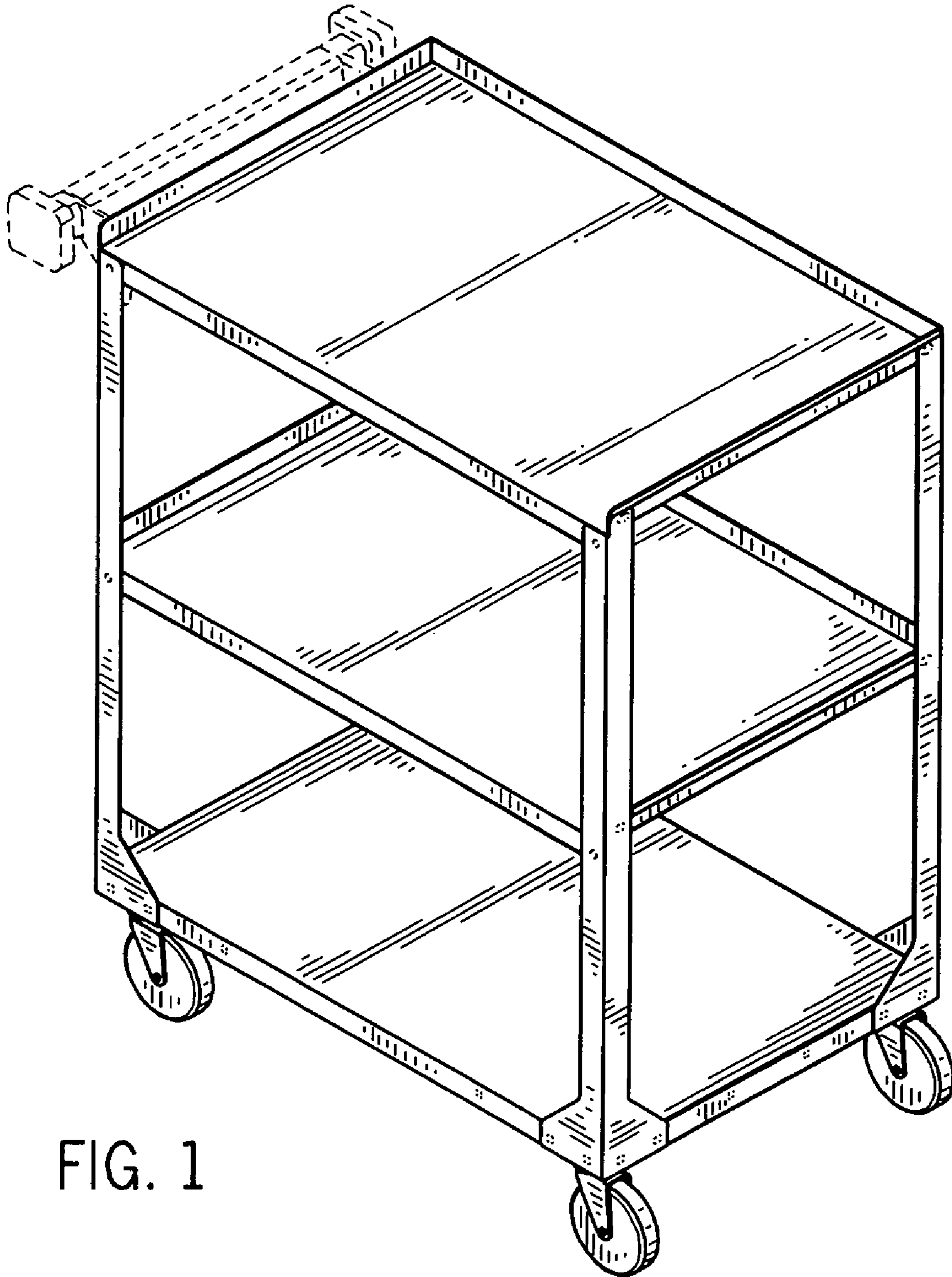

FIG. 1

FIG. 2

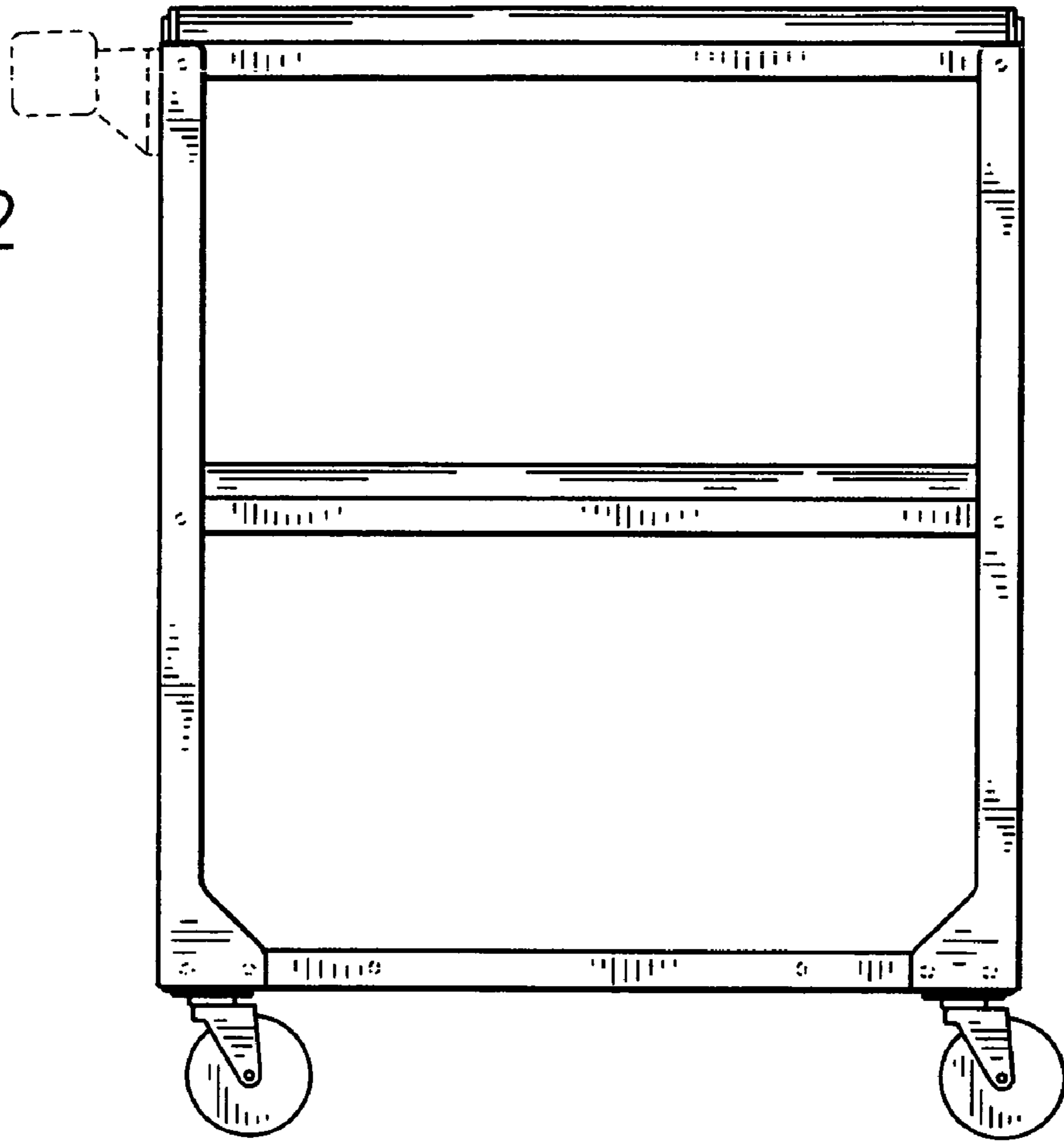
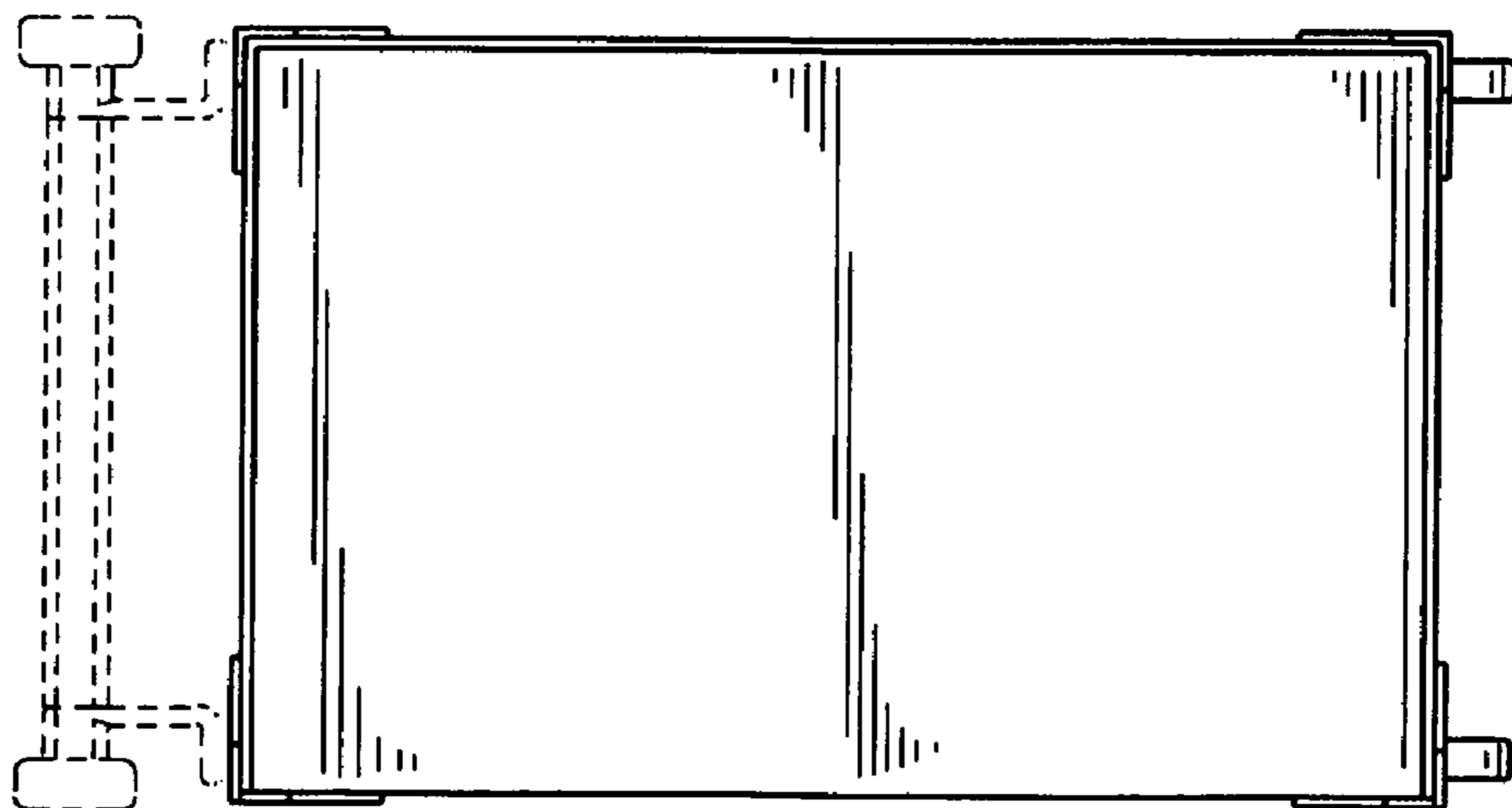

FIG. 3



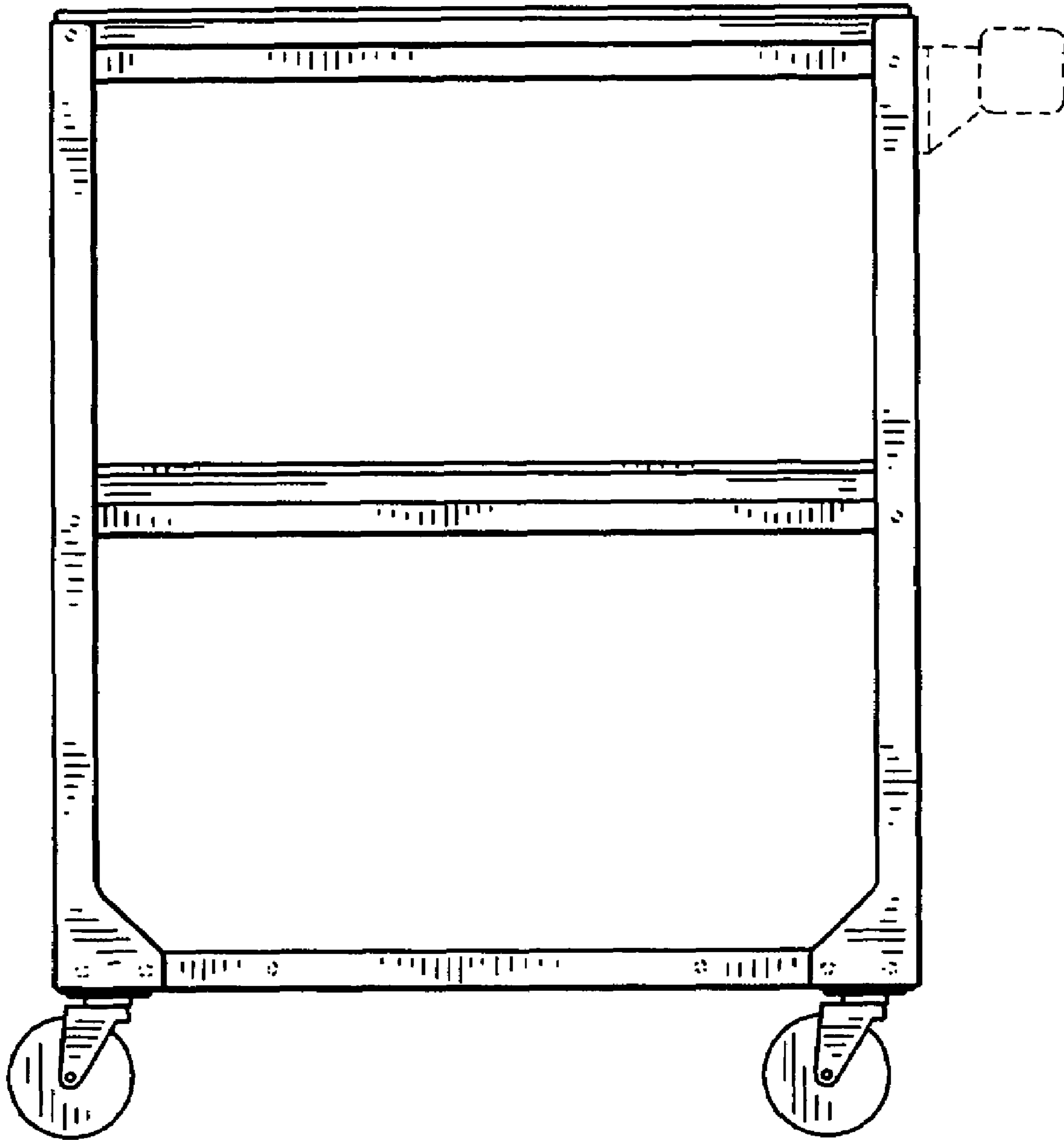

FIG. 4

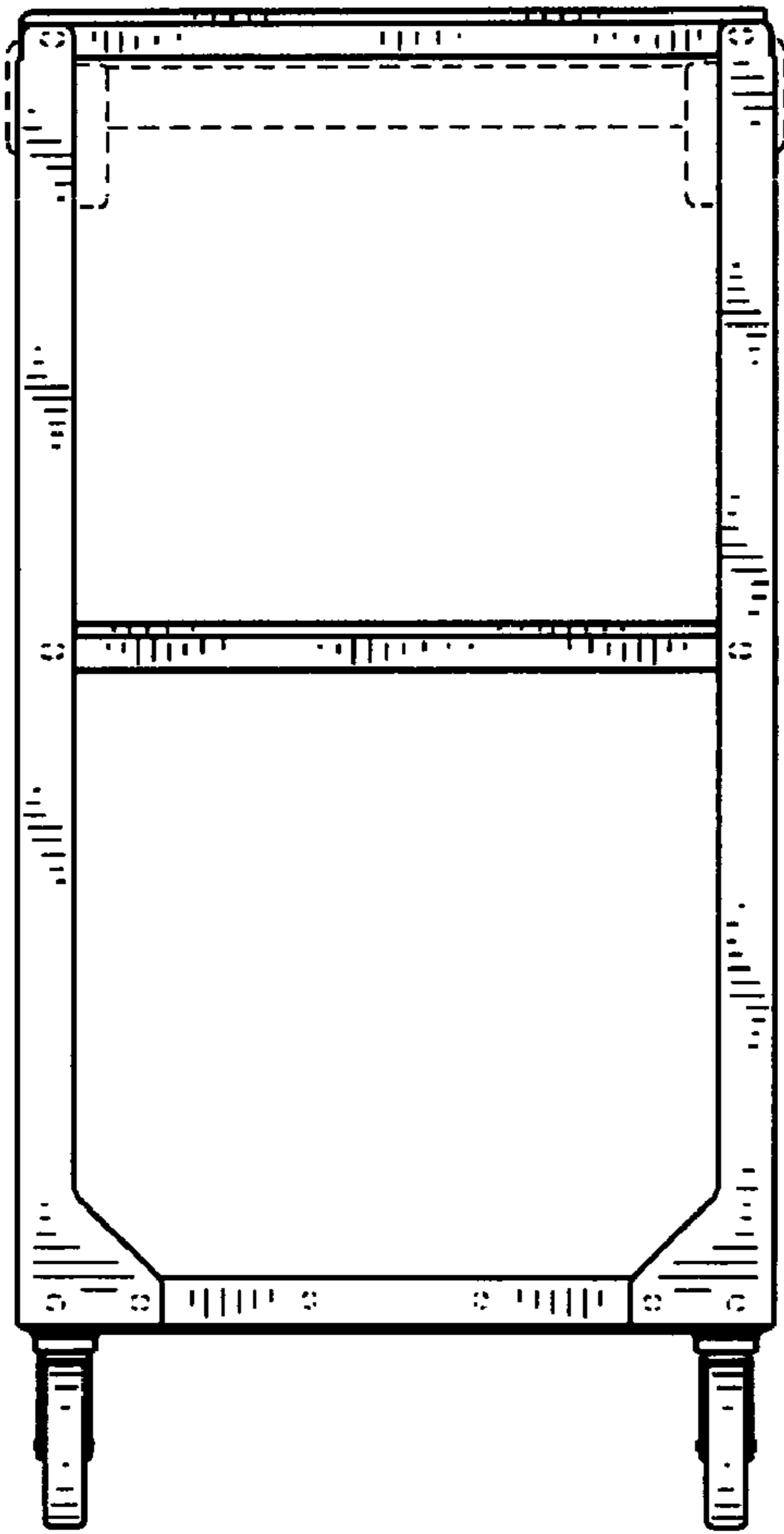

FIG. 5

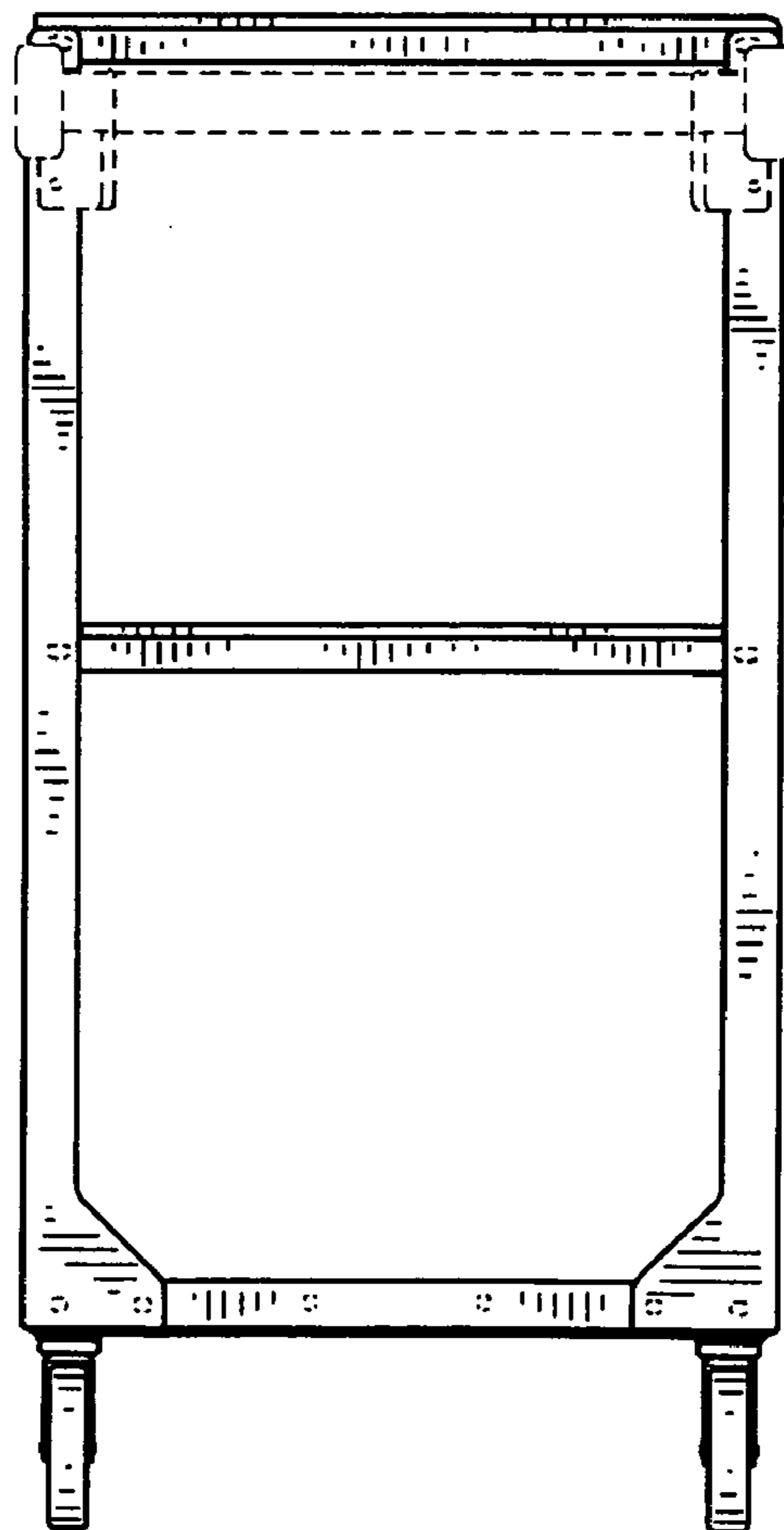

FIG. 6

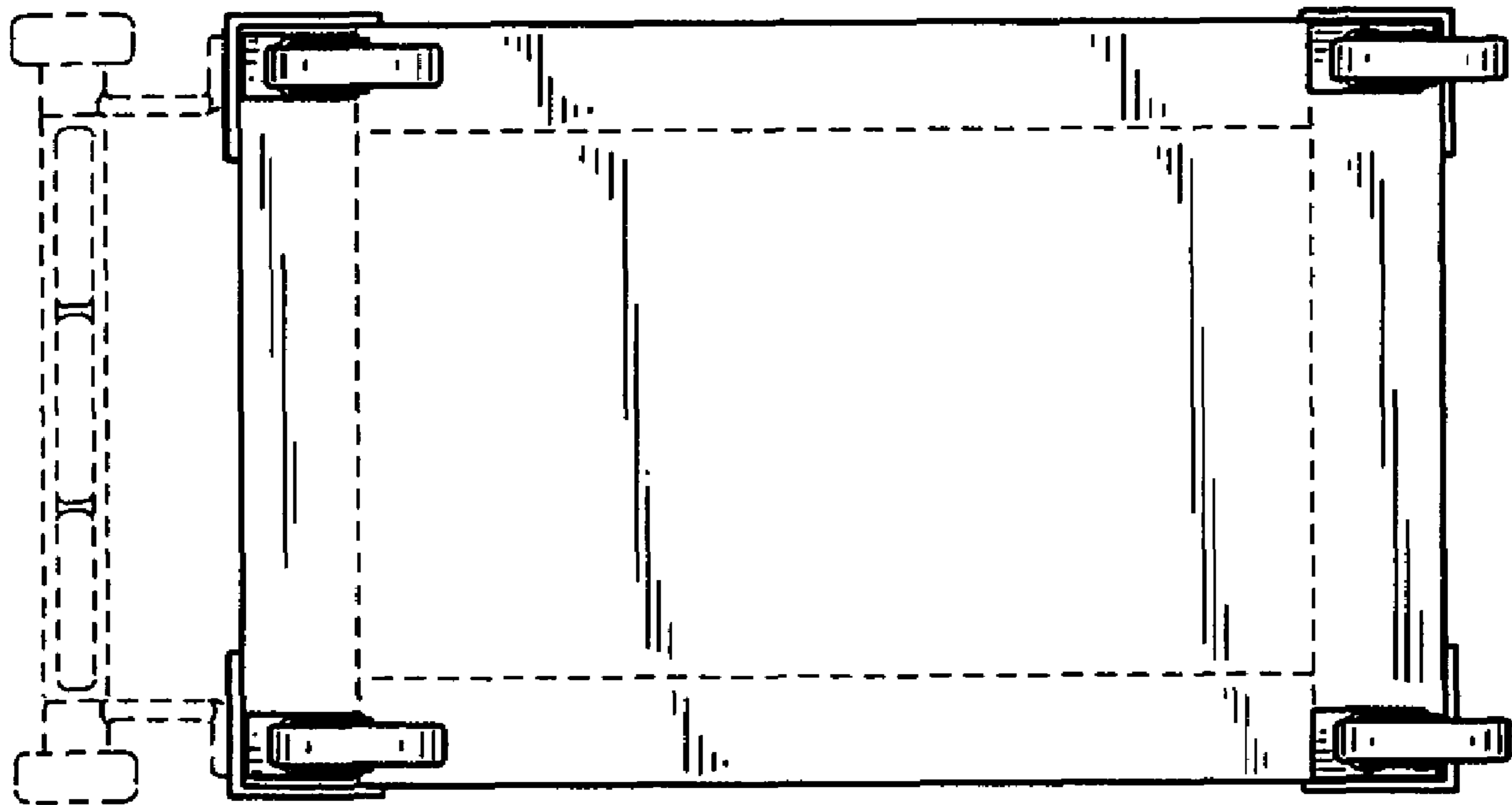

FIG. 7

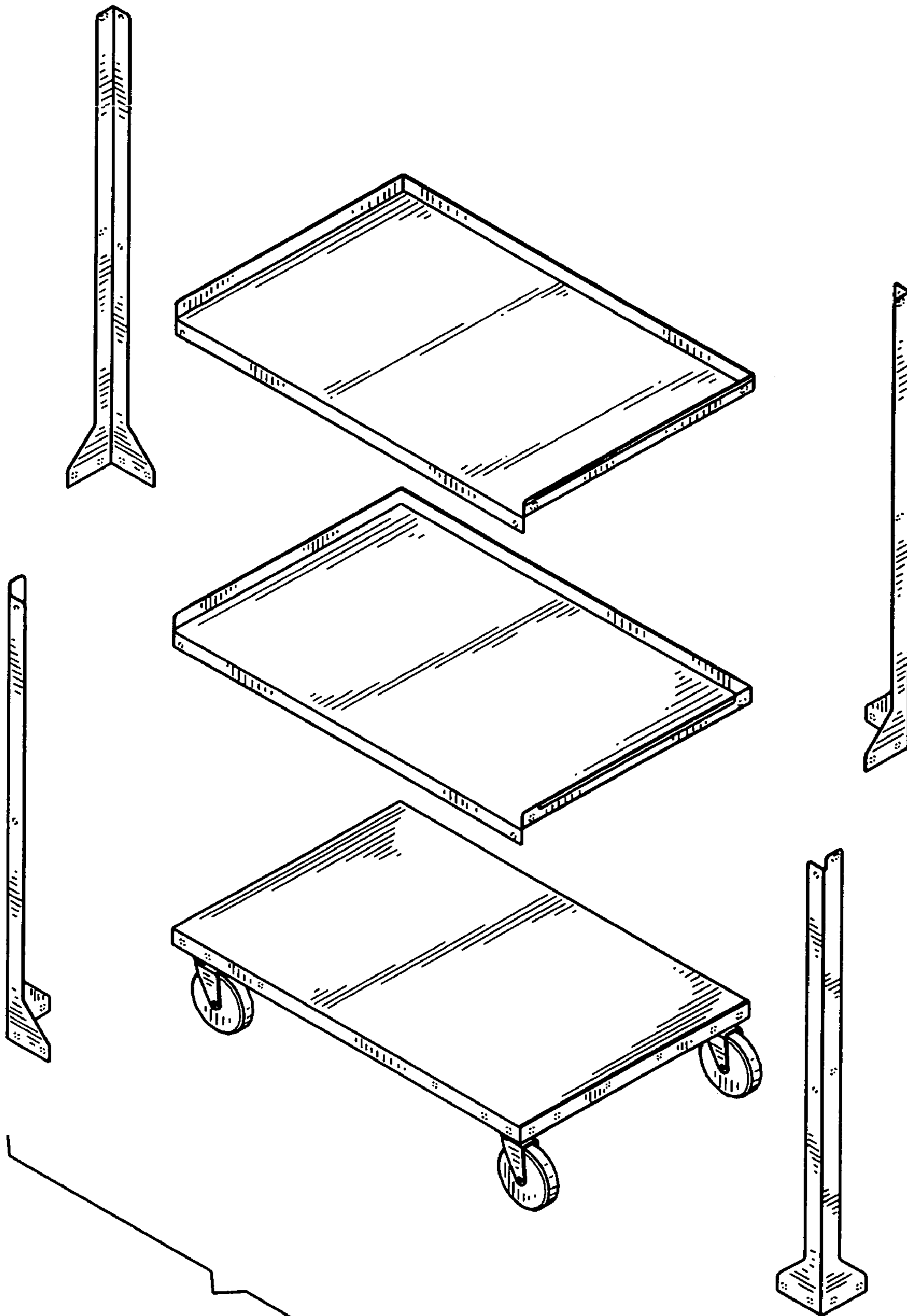

FIG. 8

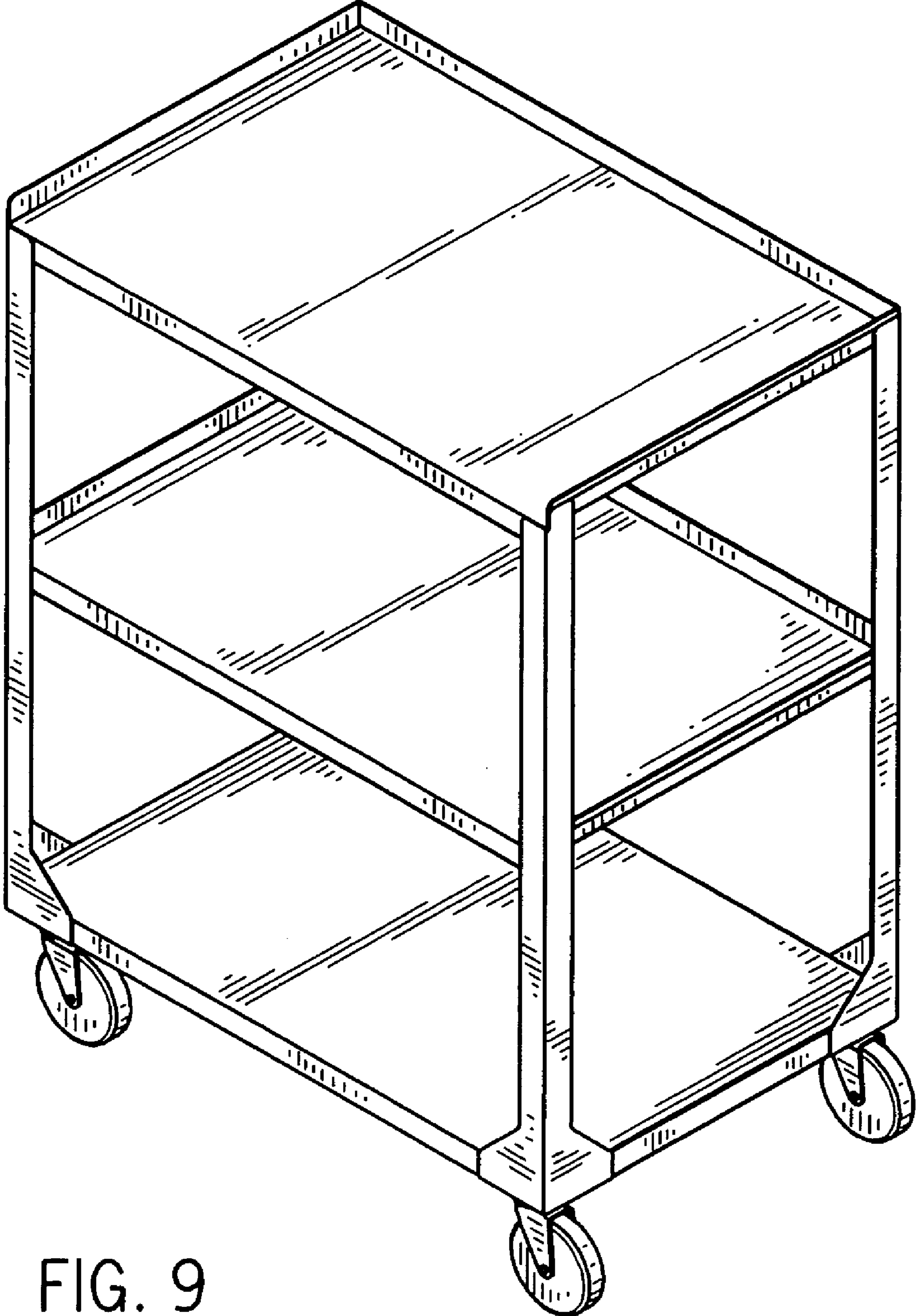

FIG. 9

FIG. 10

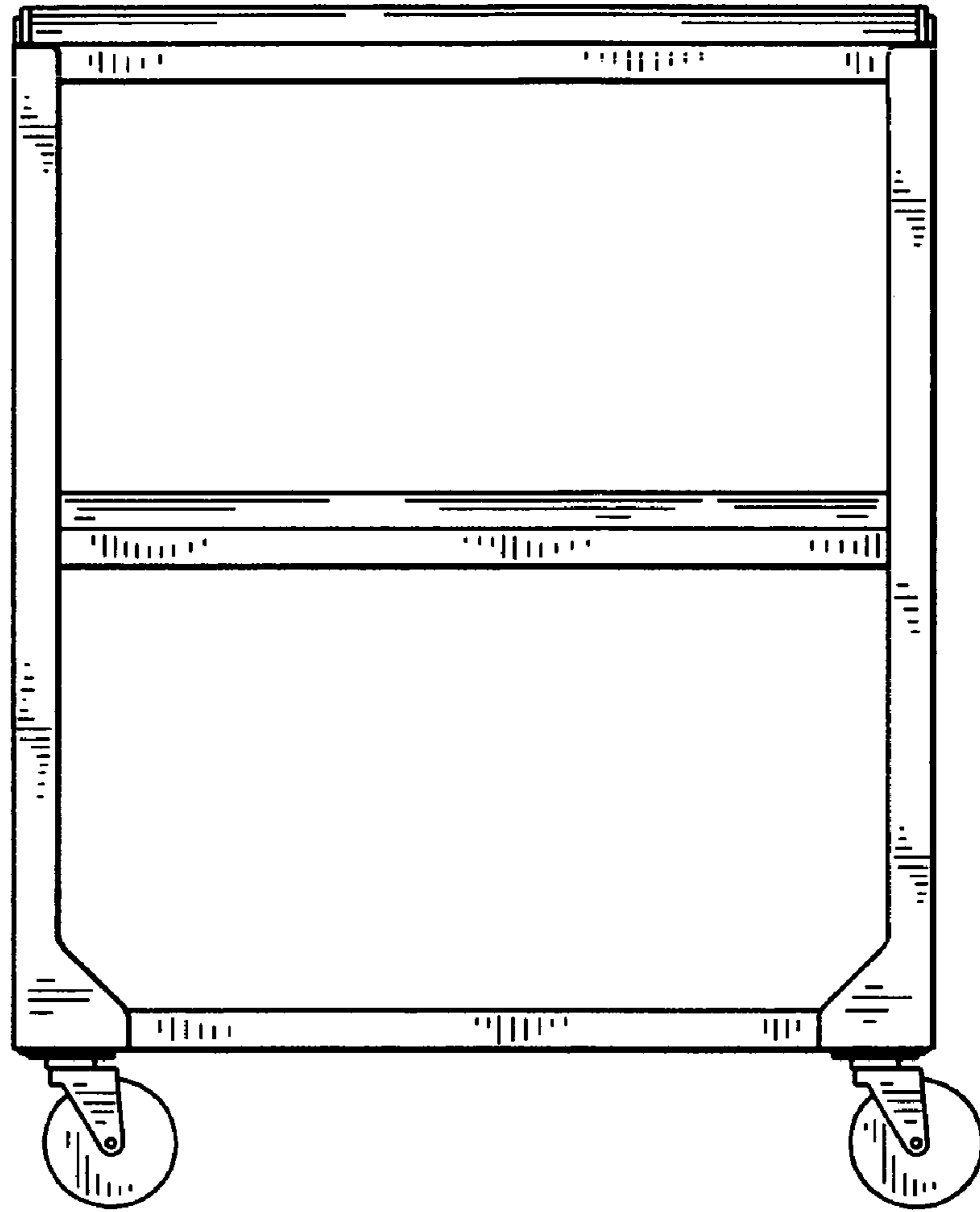
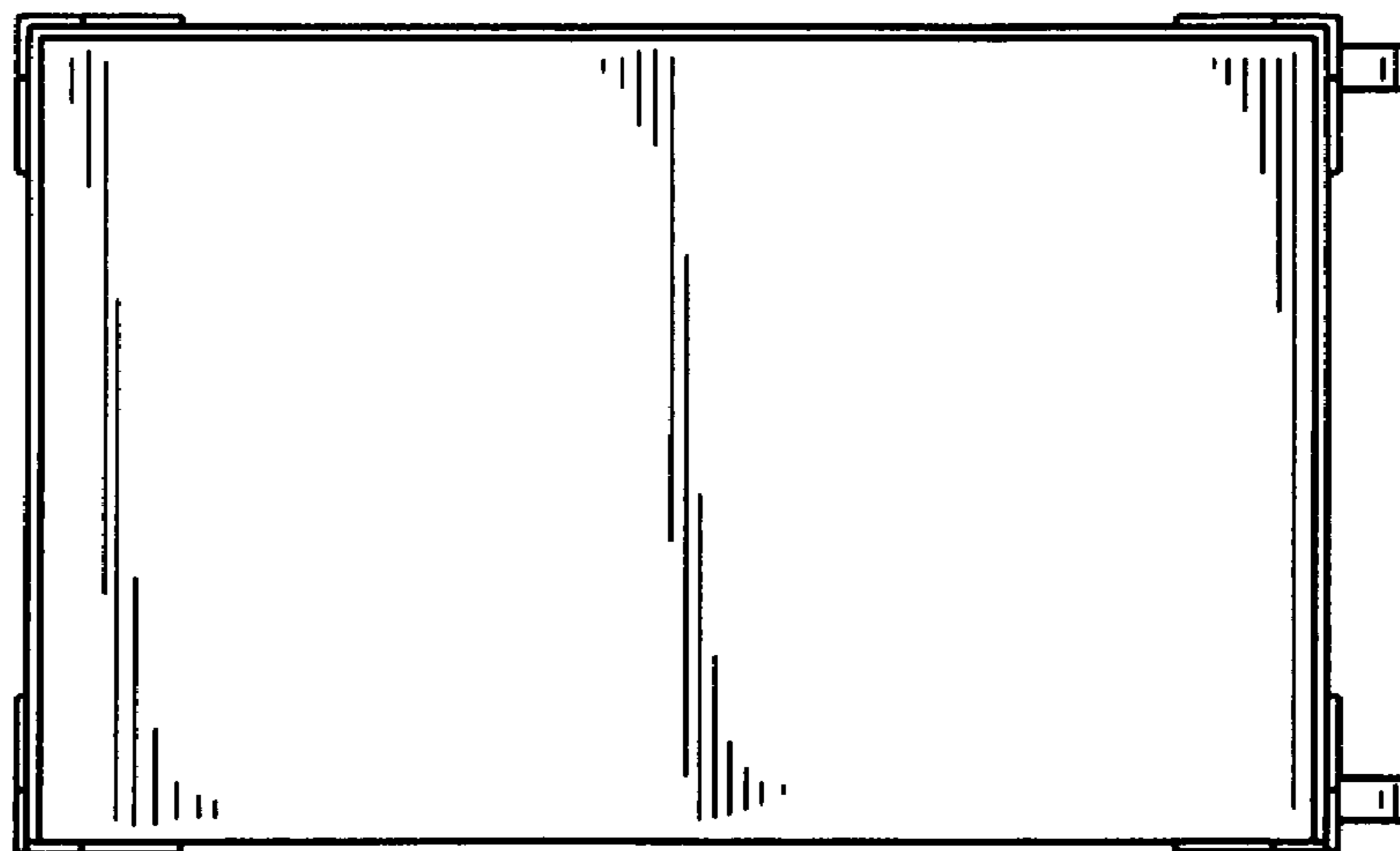

FIG. 11



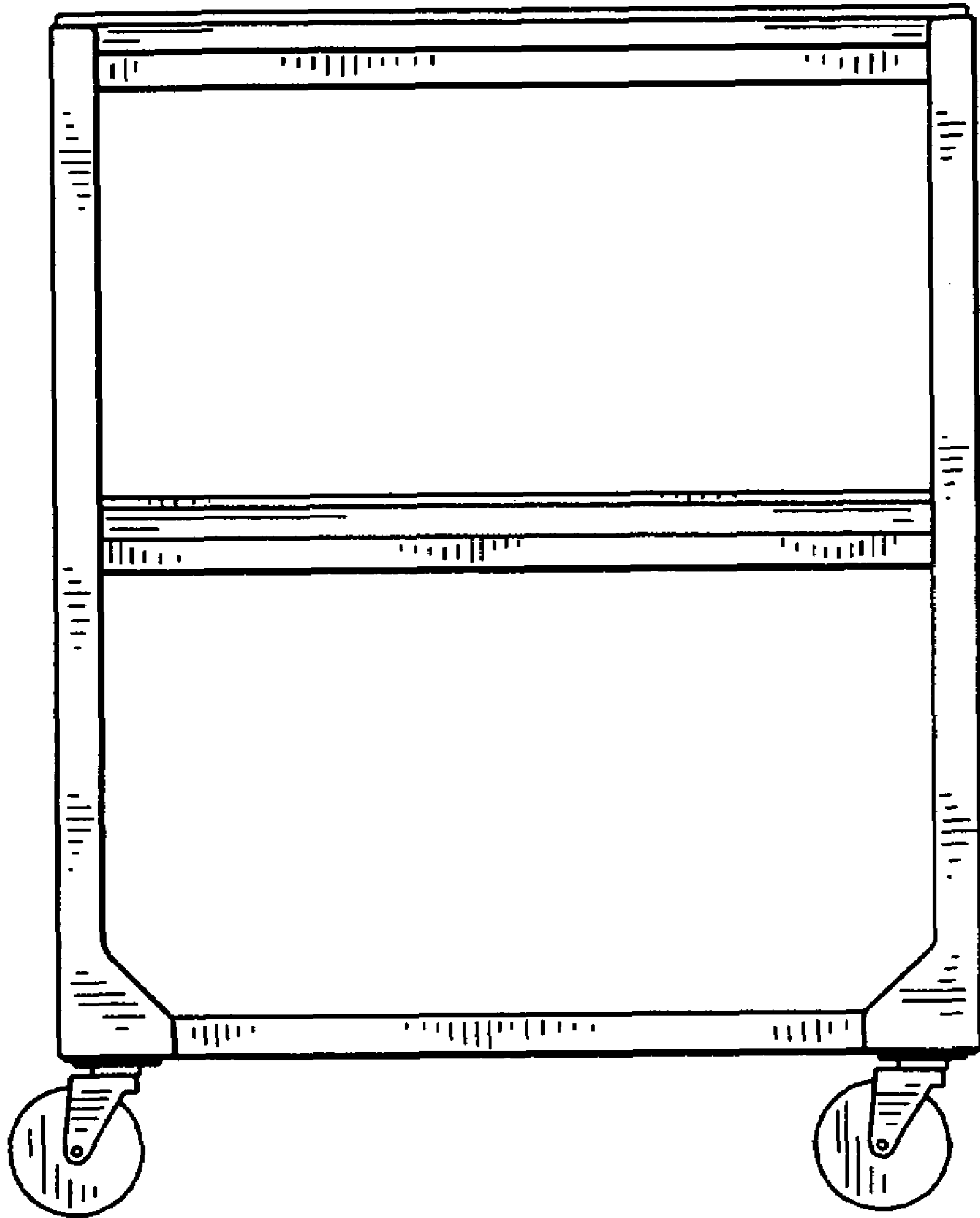

FIG. 12

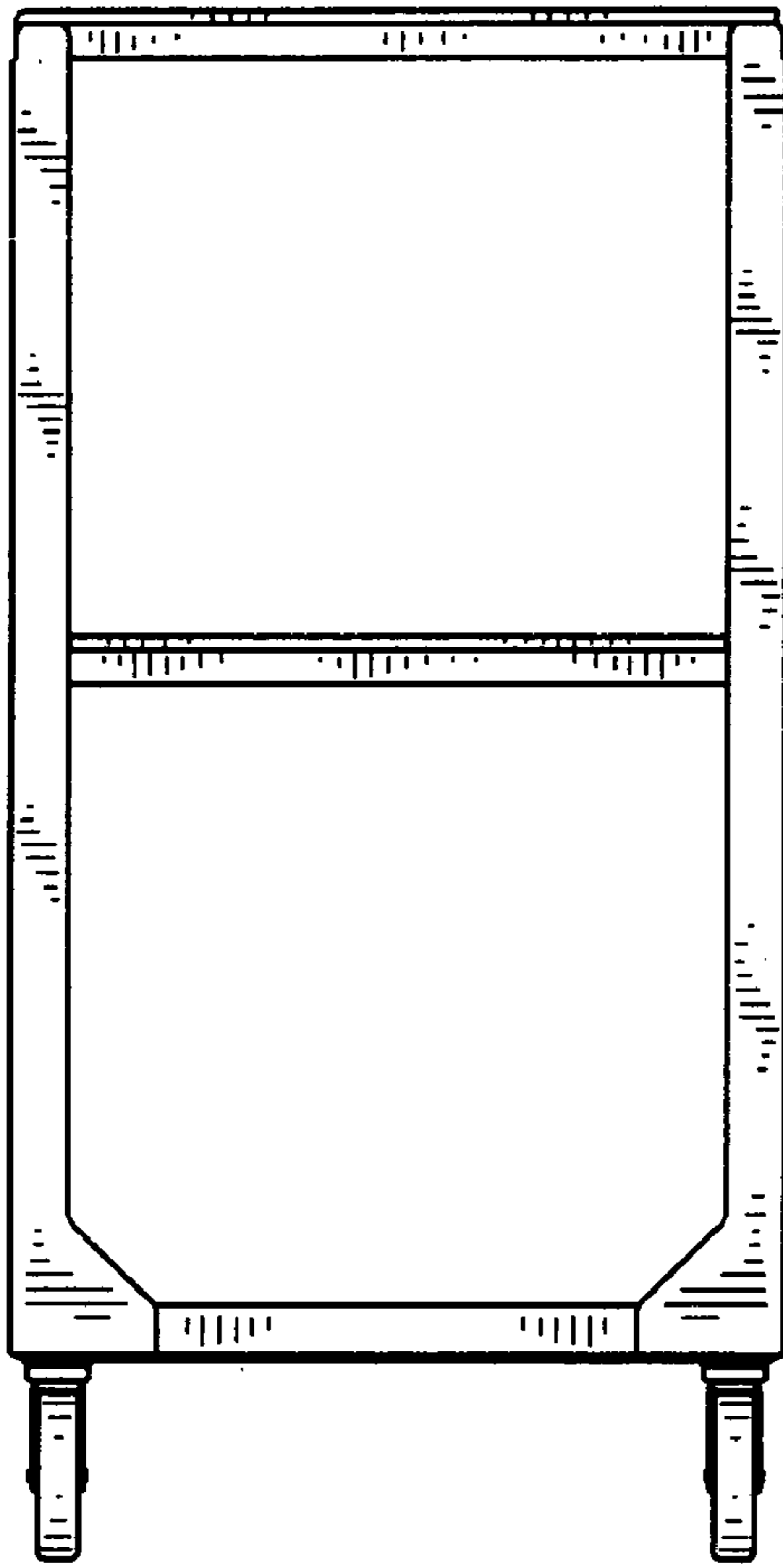

FIG. 13

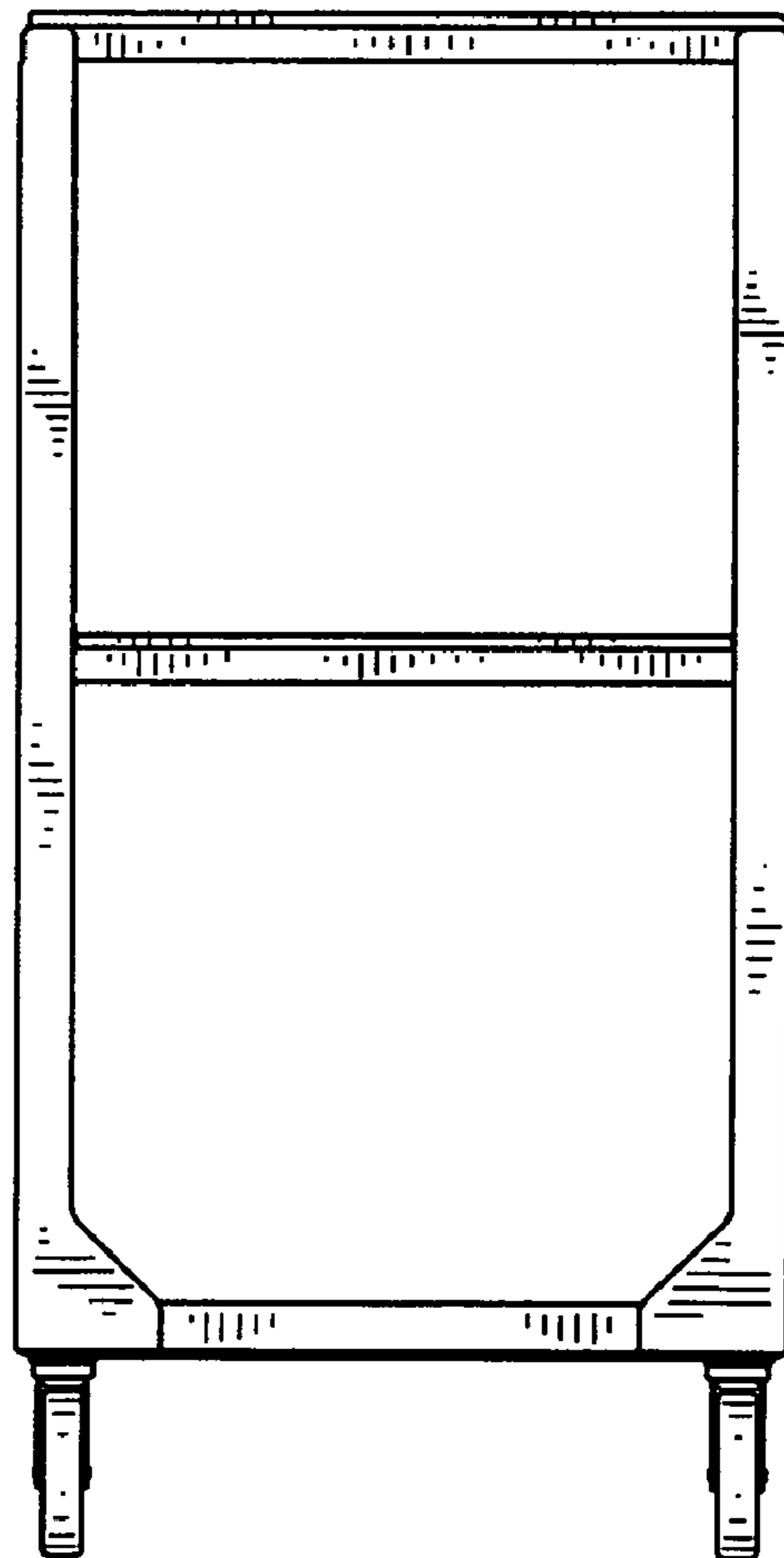

FIG. 14



FIG. 15