



US00D561767S

(12) **United States Design Patent**
Chen et al.

(10) **Patent No.:** **US D561,767 S**

(45) **Date of Patent:** **** Feb. 12, 2008**

(54) **COMPUTER FRONT BEZEL**

(75) Inventors: **Yun-Lung Chen**, Tu-Cheng (TW);
Ning-Bo Pan, Shenzhen (CN)

(73) Assignee: **Hon Hai Precision Industry Co., Ltd.**,
Tu-Cheng, Taipei Hsien (TW)

(**) Term: **14 Years**

(21) Appl. No.: **29/266,511**

(22) Filed: **Sep. 22, 2006**

(51) **LOC (8) Cl.** **14-02**

(52) **U.S. Cl.** **D14/442**

(58) **Field of Classification Search** D14/441-446,
D14/308, 439; D13/162, 184, 199; 312/223.2;
361/680-686, 690-696; 369/14, 34.01, 36.01
See application file for complete search history.

(56) **References Cited**

U.S. PATENT DOCUMENTS

D407,082 S *	3/1999	Waalder	D14/442
D482,695 S *	11/2003	Storti et al.	D14/444
D491,189 S *	6/2004	Williams	D14/439
D499,108 S *	11/2004	Chen et al.	D14/446
D499,421 S *	12/2004	Zhang et al.	D14/445

* cited by examiner

Primary Examiner—Freda S Nunn

(74) *Attorney, Agent, or Firm*—Wei Te Chung

(57) **CLAIM**

The ornamental design for a computer front bezel, as shown and described.

DESCRIPTION

FIG. 1 is a perspective view of the design for the computer front bezel wherein broken lines illustrate environmental features;

FIG. 2 is a front elevational view thereof;

FIG. 3 is a left side elevational view thereof;

FIG. 4 is a right side elevational view thereof;

FIG. 5 is a top plan view thereof;

FIG. 6 is a bottom plan view thereof; and,

FIG. 7 is a perspective view thereof being mounted to a computer case which is shown in broken lines for illustrative purposes only and forms no part of the claimed design.

The broken line showing of computer front bezel is for the purpose of illustrating environmental structures and forms no part of the claimed design.

1 Claim, 6 Drawing Sheets

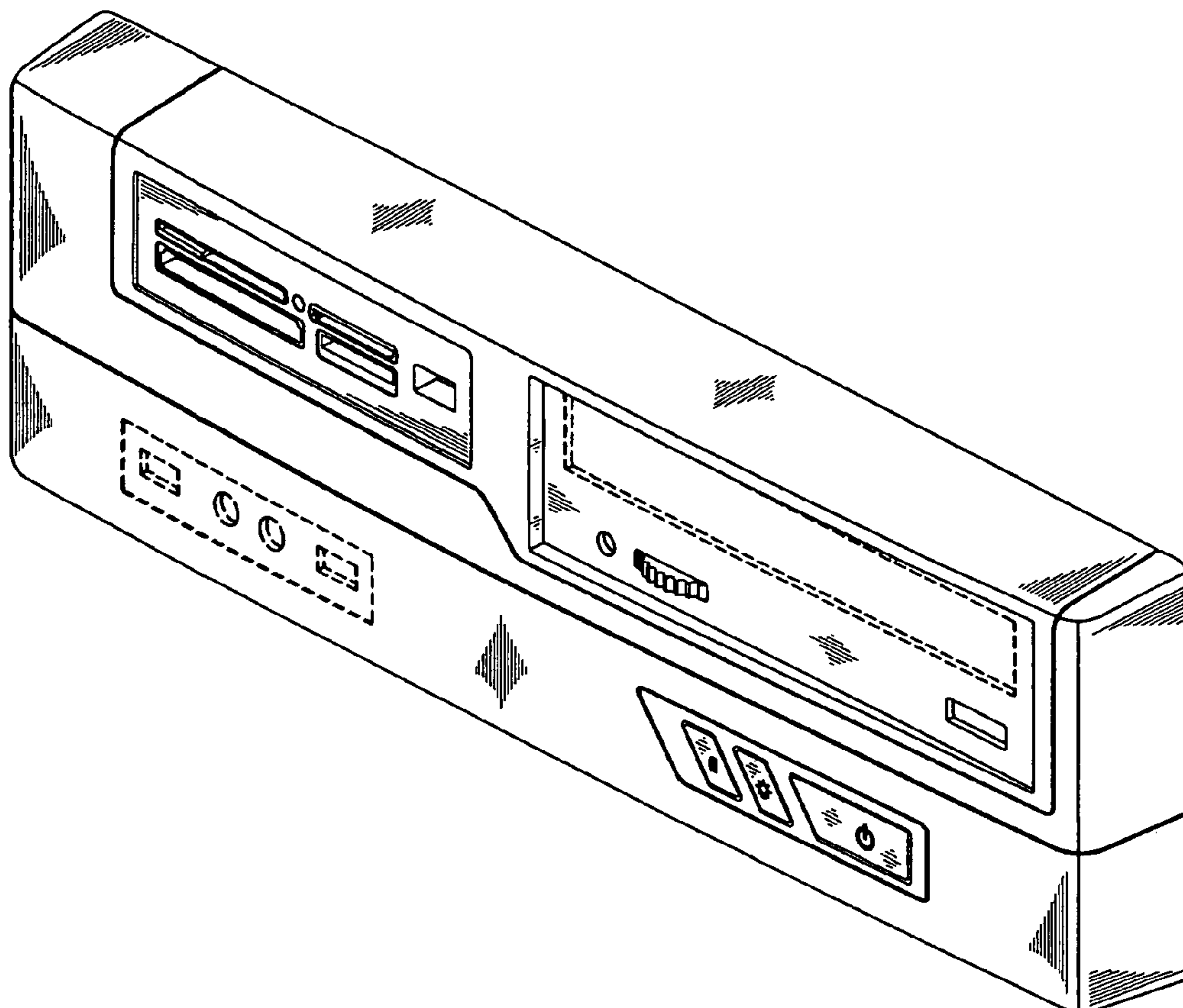

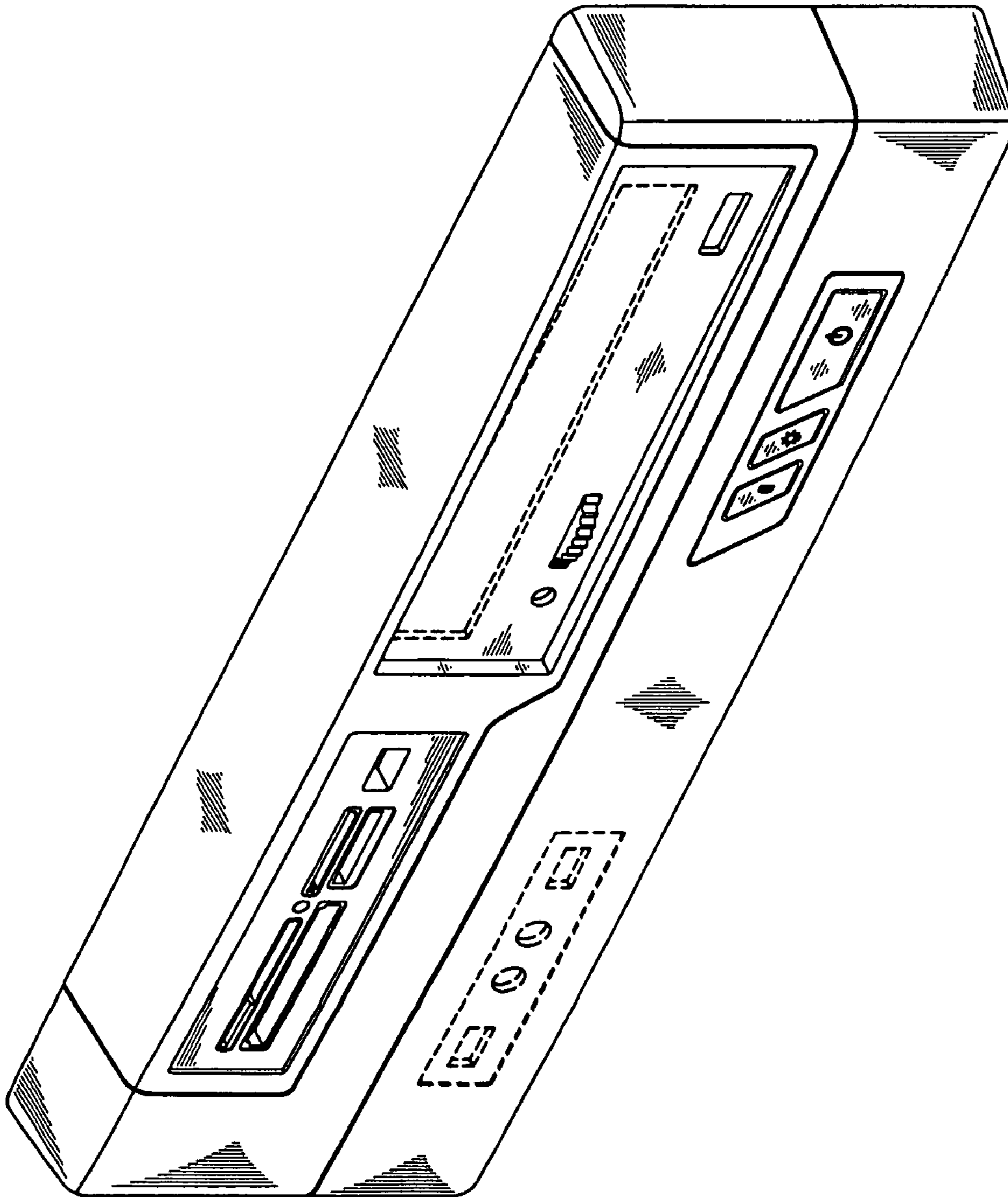

FIG. 1

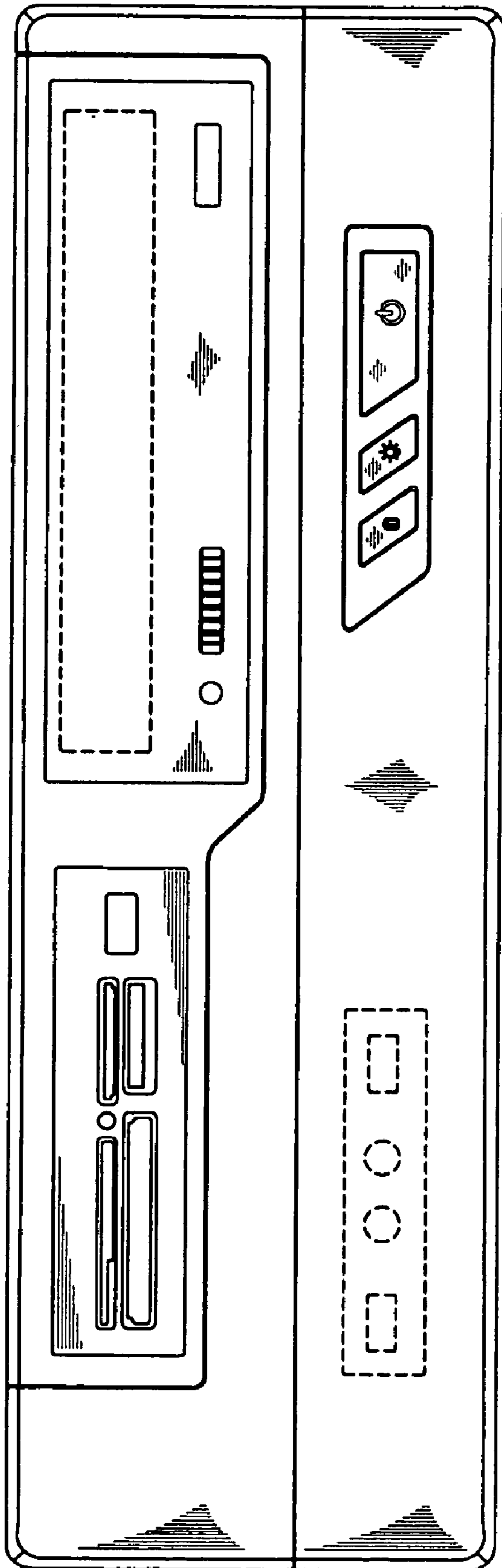

FIG. 2

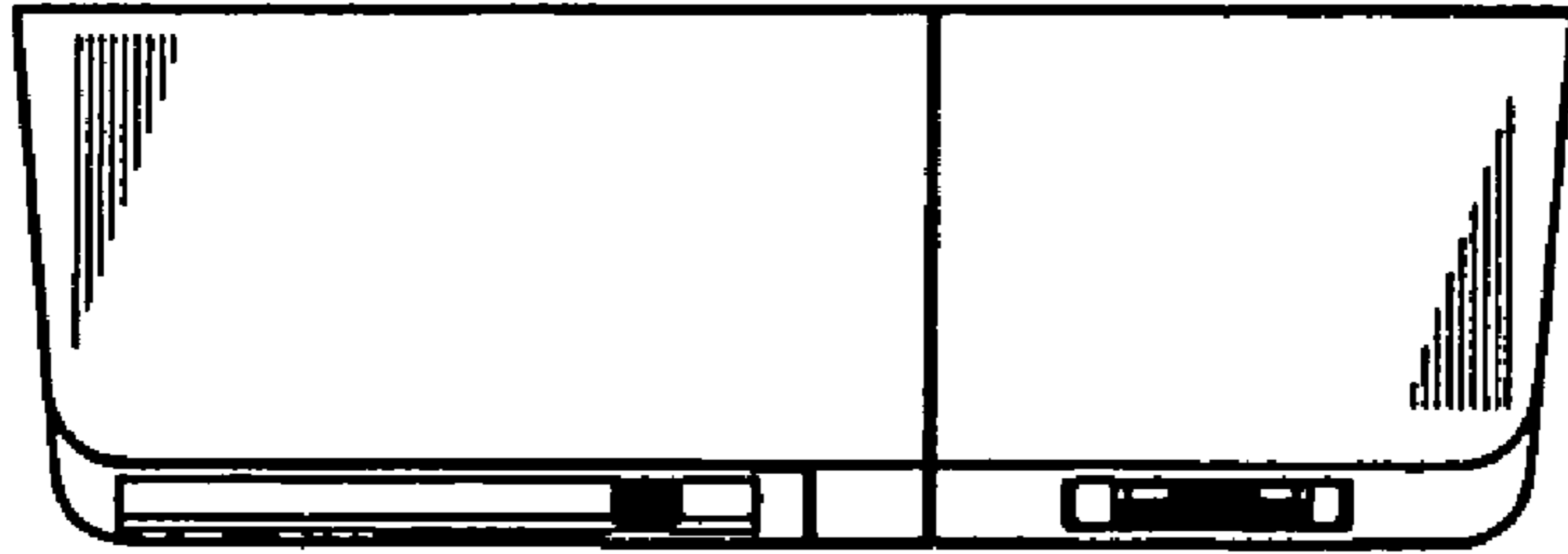

FIG. 4

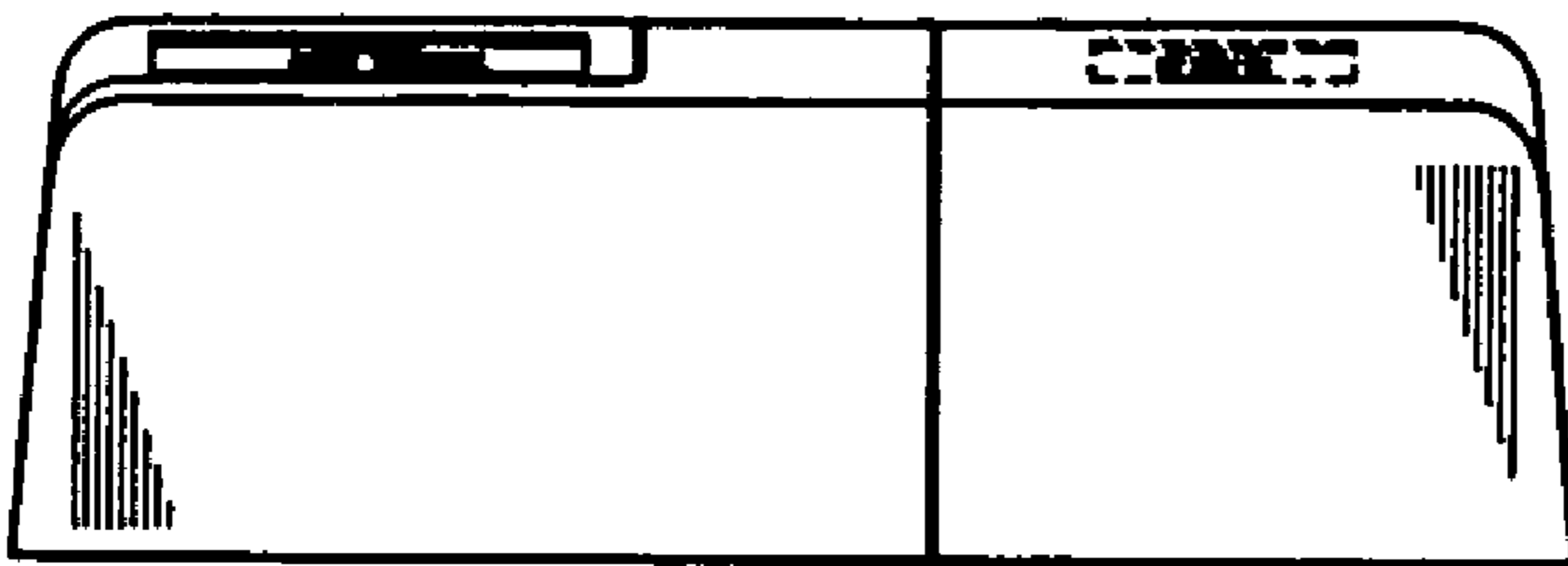

FIG. 3

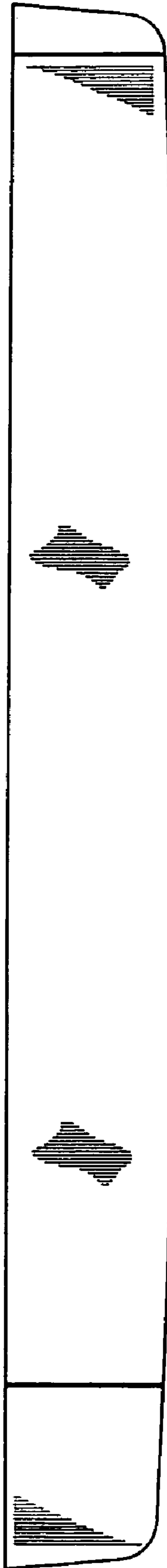

FIG. 5



FIG. 6

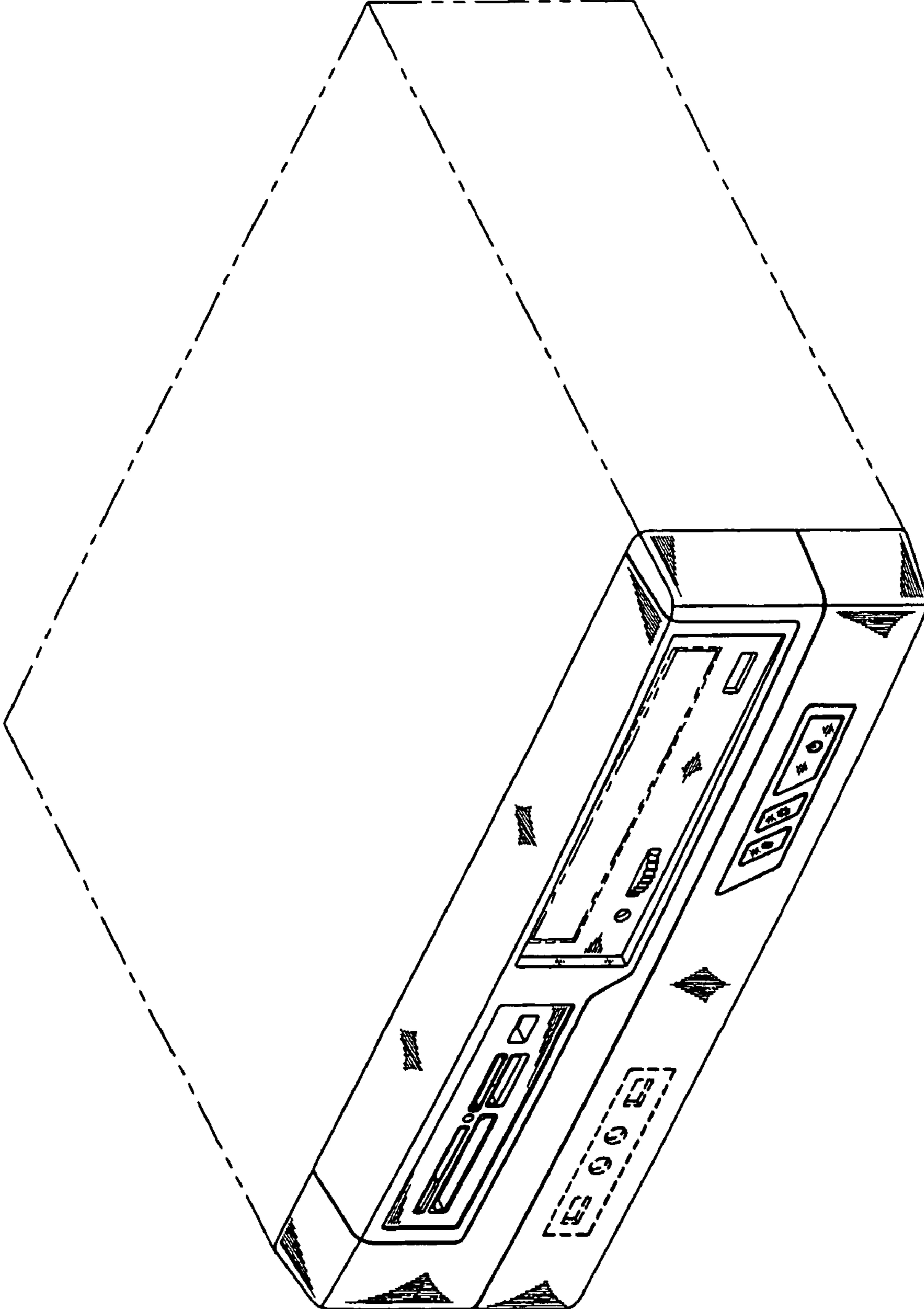

FIG. 7