



US00D561744S

(12) **United States Design Patent** (10) **Patent No.:** **US D561,744 S**
Whiteside et al. (45) **Date of Patent:** **** Feb. 12, 2008**

(54) **RADAR ARRAY**

(75) Inventors: **John B. Whiteside**, Lenexa, KS (US);
James P. Ross, Lenexa, KS (US);
Warren R. Stevens, Olathe, KS (US)

(73) Assignee: **Garmin Ltd.** (KY)

(**) Term: **14 Years**

(21) Appl. No.: **29/283,505**

(22) Filed: **Aug. 16, 2007**

Related U.S. Application Data

(63) Continuation of application No. 29/255,784, filed on Mar. 10, 2006, now Pat. No. Des. 554,110.

(51) **LOC (8) Cl.** **14-03**

(52) **U.S. Cl.** **D14/230**

(58) **Field of Classification Search** D10/68;
D14/230, 234, 235, 236, 237; 342/158, 359;
343/763, 767, 872, 756, 771
See application file for complete search history.

(56) **References Cited**

U.S. PATENT DOCUMENTS

3,196,349	A *	7/1965	Fryklund	342/158
D326,097	S *	5/1992	Ferrario	D14/230
5,134,409	A *	7/1992	De Groot	342/158
D516,060	S *	2/2006	Wu	D14/230

OTHER PUBLICATIONS

Si-Tex Marine Electronics; from <http://www.si-tex.com>, taken from web site Mar. 8, 2006, 13 pages.

Excerpt from Furuno Electronic Co., Ltd. Marine Radar Model 1932 Mark-2/1942 Mark-2 Operator's Manual; Nishinomiya, Japan, 1998, 3 pages.

Excerpt from Furuno Electronic Co., Ltd. Marine Radar Model 1832/1932/1942 Operator's Manual; Nishinomiya, Japan, 1997, 7 pages.

Excerpt from Raymarine Ltd., Pathfinder Radar Scanners Owner's Handbook; 2004, 7 pages.

* cited by examiner

Primary Examiner—Antoine D. Davis

(74) *Attorney, Agent, or Firm*—Kevin E. West; Samuel M. Korte

(57) **CLAIM**

The ornamental design for a radar array, as shown and described.

DESCRIPTION

FIG. 1 is a perspective view of a radar array according to the present invention;

FIG. 2 is a rear elevational view thereof;

FIG. 3 is a front elevational view thereof;

FIG. 4 is a top plan view thereof;

FIG. 5 is a bottom plan view thereof;

FIG. 6 is a left side elevational view thereof; and,

FIG. 7 is a rear elevational view thereof.

Those portions shown in broken lines for illustrative purposes only and forming no part of the claimed design.

1 Claim, 3 Drawing Sheets

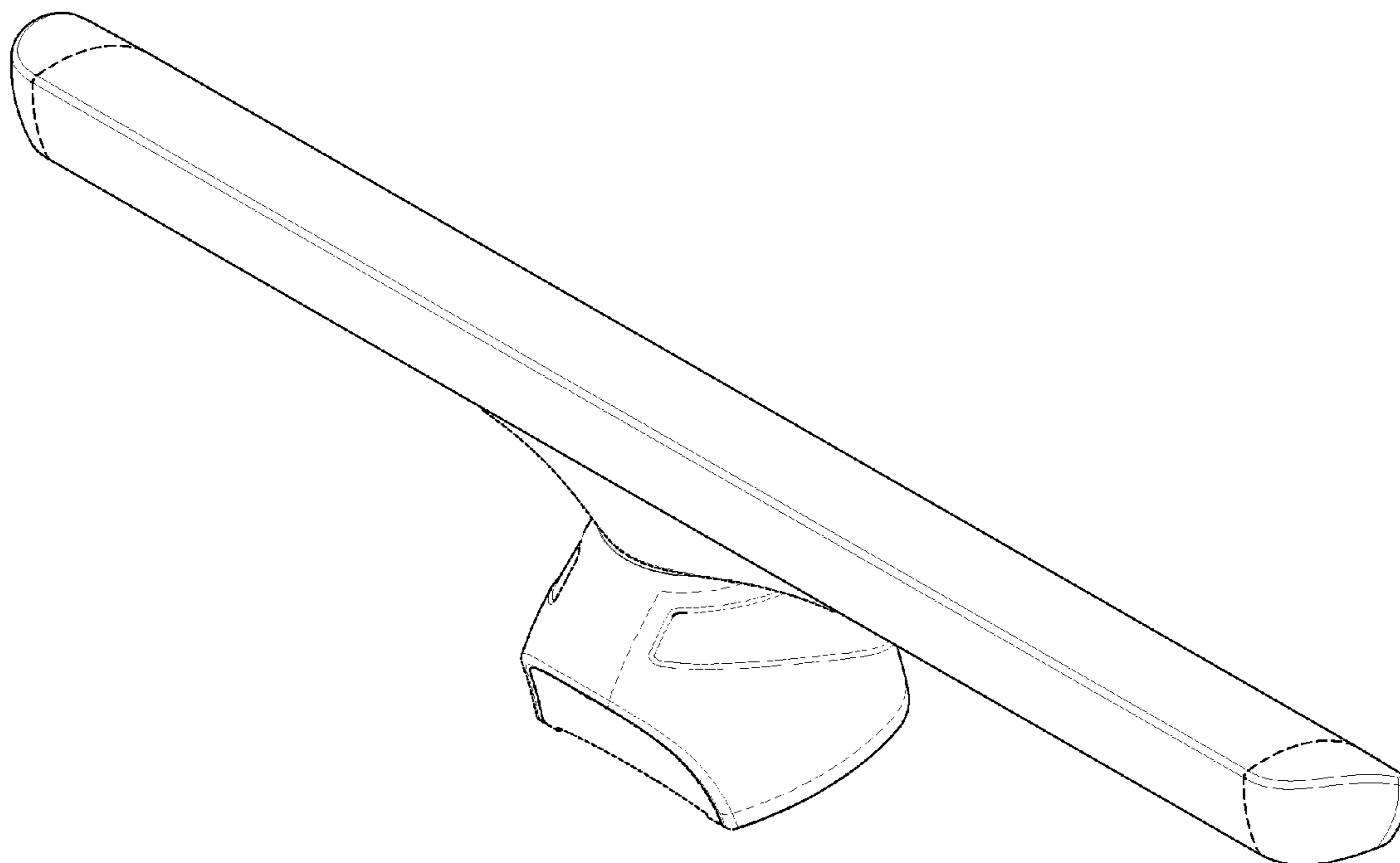

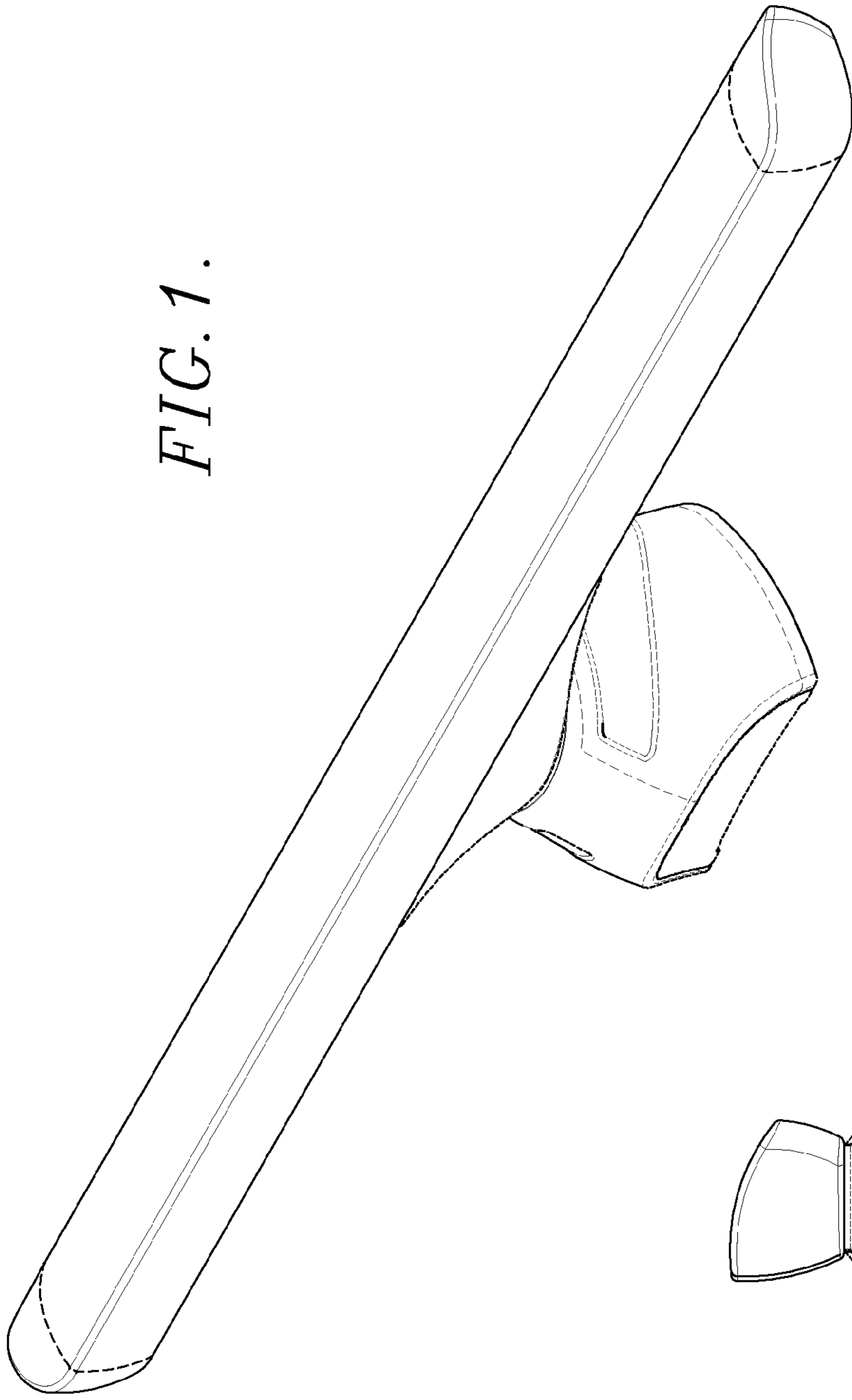

FIG. 1.

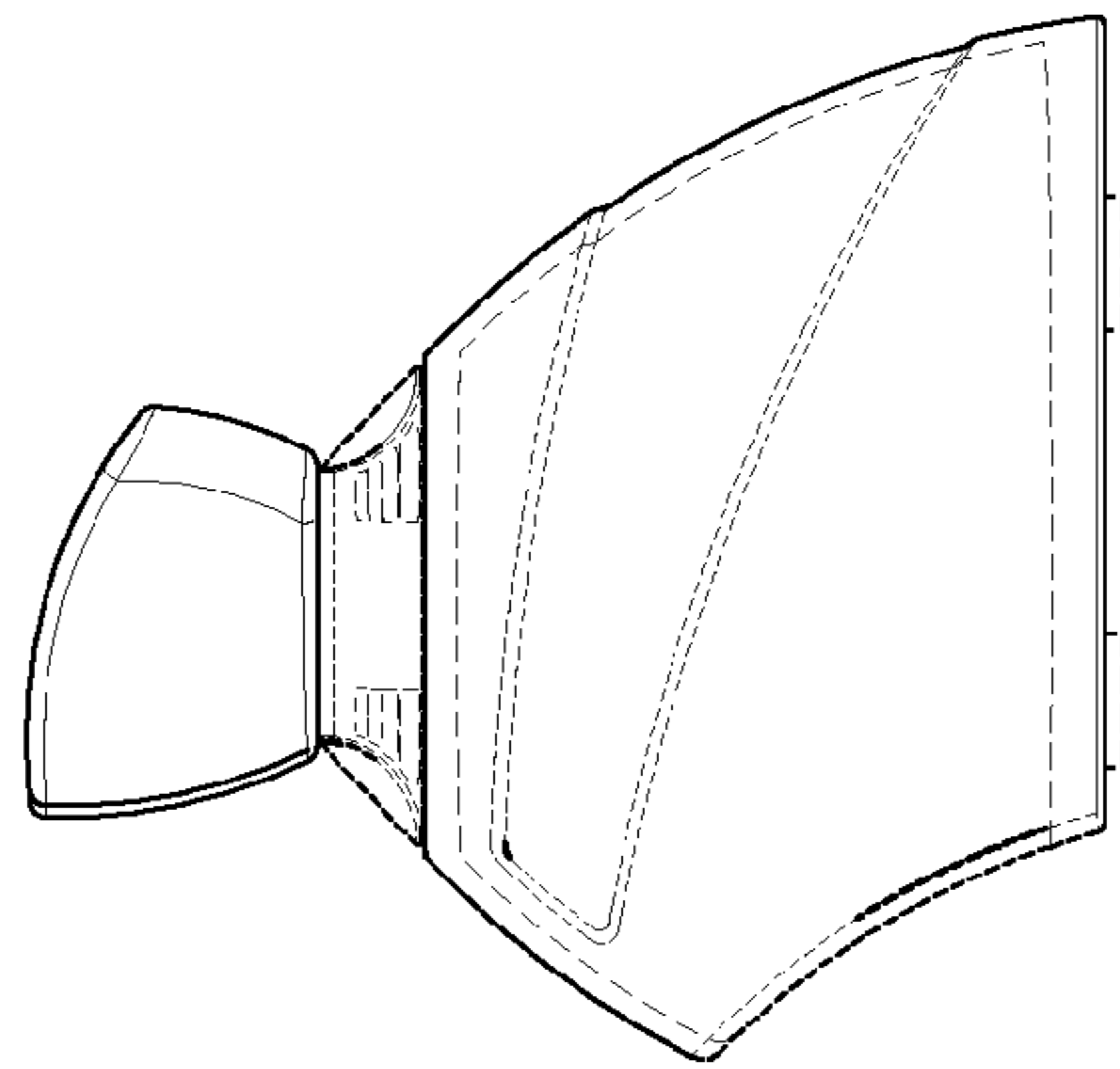

FIG. 6.

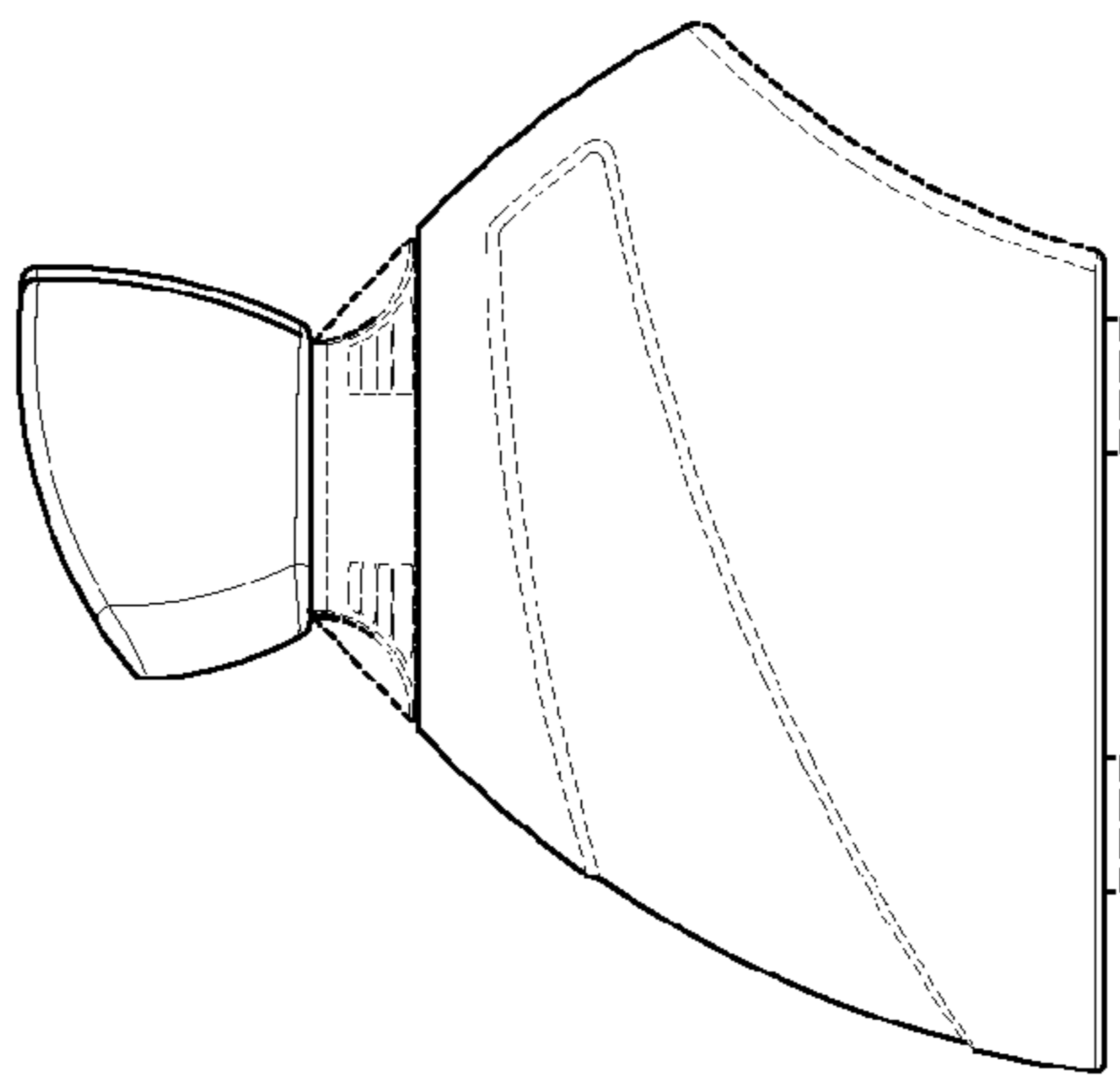

FIG. 7.

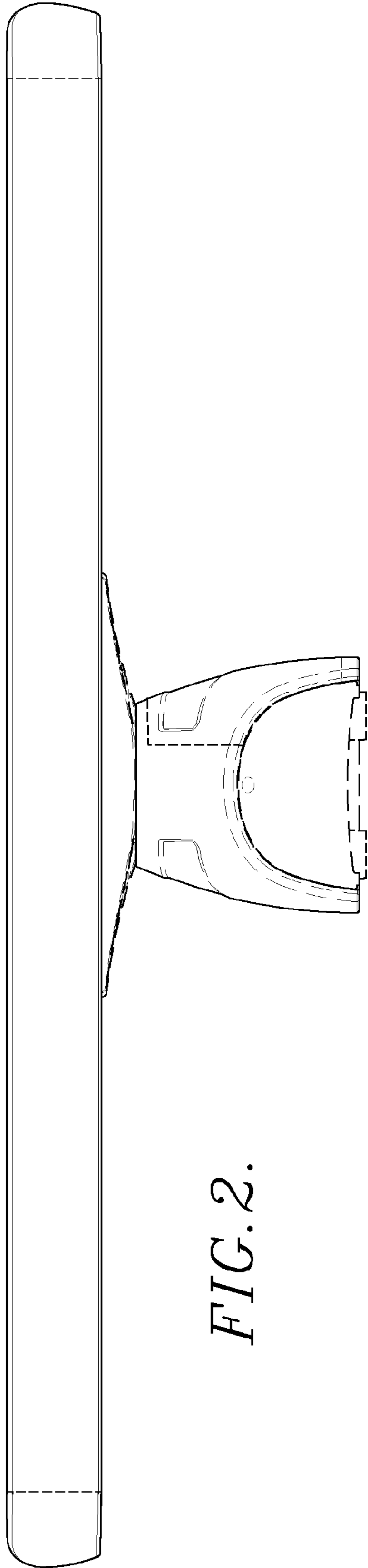

FIG. 2.

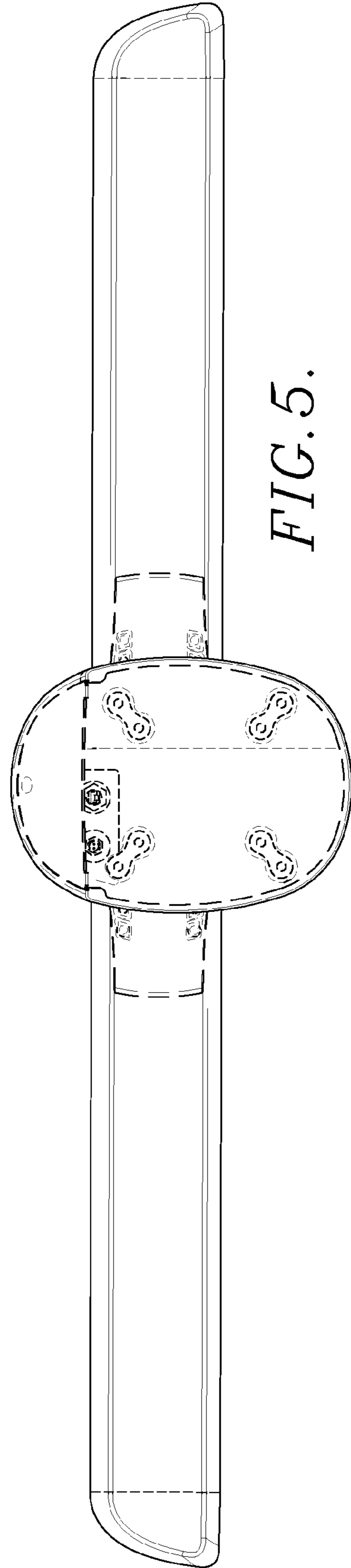

FIG. 5.

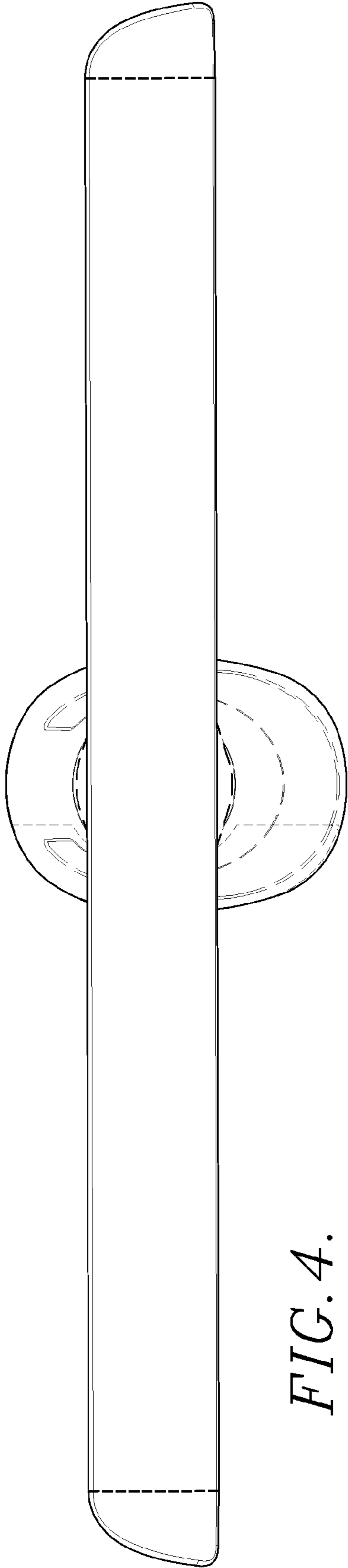

FIG. 4.

FIG. 3.

