



US00D561677S

(12) **United States Design Patent** (10) **Patent No.:** **US D561,677 S**
Wai (45) **Date of Patent:** **** Feb. 12, 2008**

(54) **HELICOPTER** 1,773,281 A 8/1930 Scott
1,800,470 A 4/1931 Oehmichen
(75) Inventor: **Chi Pok Billy Wai**, Quarry Bay (HK)
(73) Assignee: **Silverlit Toys Manufactory, Ltd.**,
Hong Kong (HK)

(Continued)

(**) Term: **14 Years**

(21) Appl. No.: **29/283,034**

FOREIGN PATENT DOCUMENTS

(22) Filed: **Aug. 3, 2007**

BE 338599 12/1926

Related U.S. Application Data

(63) Continuation-in-part of application No. 11/627,919, filed on Jan. 26, 2007, which is a continuation-in-part of application No. 11/465,781, filed on Aug. 18, 2006, which is a continuation-in-part of application No. 11/462,177, filed on Aug. 3, 2006, application No. 29/283,034, and a continuation-in-part of application No. 29/275,322, filed on Dec. 20, 2006, now Pat. No. Des. 546,269, and a continuation-in-part of application No. 29/275,323, filed on Dec. 20, 2006, now Pat. No. Des. 544,825, and a continuation-in-part of application No. 29/275,324, filed on Dec. 20, 2006, now Pat. No. Des. 545,755, and a continuation-in-part of application No. 29/277,652, filed on Mar. 5, 2007, now Pat. No. Des. 552,531, and a continuation-in-part of application No. 29/280,187, filed on May 18, 2007, now Pat. No. Des. 554,040.

(Continued)

OTHER PUBLICATIONS

Photographic prior art reference #1, helicopter.

(Continued)

Primary Examiner—Ian Simmons
Assistant Examiner—Maurice Stevens
(74) *Attorney, Agent, or Firm*—Greenberg Traurig, LLP

(57) **CLAIM**

The ornamental design for a helicopter, as shown and described.

(30) **Foreign Application Priority Data**

Jan. 19, 2006 (BE) 2006/0043

(51) **LOC (8) Cl.** **12-07**

(52) **U.S. Cl.** **D12/326**

(58) **Field of Classification Search** D12/319–345;
244/17.11, 317.27; 446/36–45, 230, 232;
D21/441–442, 450, 453, 650, 553, 578, 585
See application file for complete search history.

(56) **References Cited**

U.S. PATENT DOCUMENTS

1,403,909 A 1/1922 Moir

DESCRIPTION

FIG. 1 is a right side view of a helicopter;
FIG. 2 is a perspective right side view of the helicopter;
FIG. 3 is a left side view of the helicopter;
FIG. 4 is a perspective left side view of the helicopter;
FIG. 5 is a front view of the helicopter; and,
FIG. 6 is a rear view of the helicopter.

Broken lines, if any, are for illustrative purposes only and form no part of the claimed design.

1 Claim, 5 Drawing Sheets

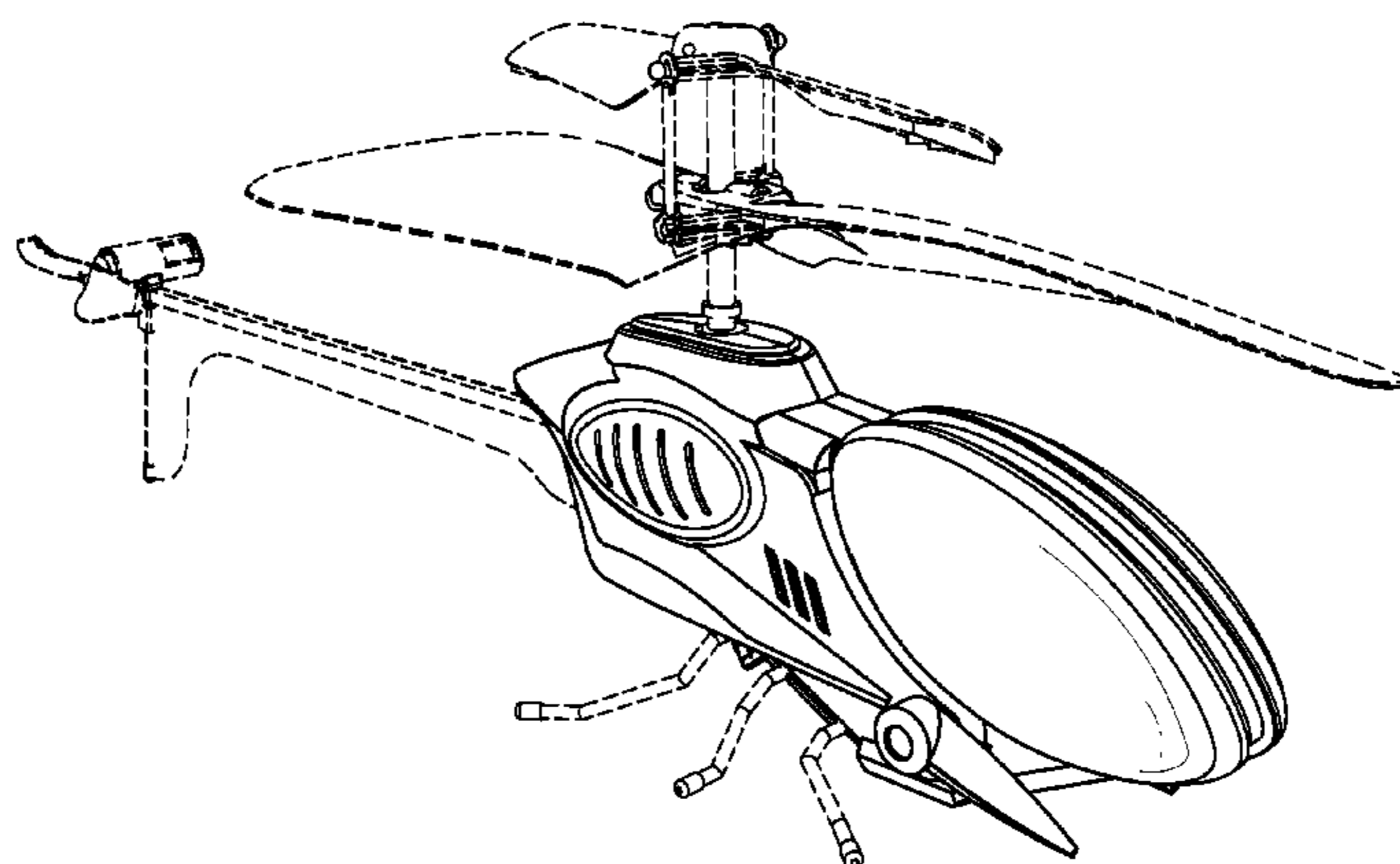

US D561,677 S

Page 2

U.S. PATENT DOCUMENTS

2,030,578 A 2/1936 Flettner
 2,384,516 A 9/1945 Young
 2,481,750 A 9/1949 Hiller, Jr. et al.
 2,532,683 A 12/1950 Traver
 D163,938 S * 7/1951 Douglas D12/329
 2,646,848 A 7/1953 Young
 D171,569 S * 3/1954 Apostolescu D12/328
 D178,081 S 6/1956 Papadakos
 2,750,131 A 6/1956 Thomson
 3,029,048 A 4/1962 Brooks et al.
 3,080,001 A 3/1963 Culver et al.
 3,409,249 A 11/1968 Bergquist et al.
 3,592,559 A 7/1971 Ward
 4,025,230 A 5/1977 Kastan
 4,307,533 A 12/1981 Sims et al.
 4,447,023 A * 5/1984 Reid 244/17.11
 4,629,440 A 12/1986 McKittrick, Jr. et al.
 D294,605 S * 3/1988 Matsumoto D21/583
 5,240,204 A 8/1993 Kunz
 5,255,871 A 10/1993 Ikeda
 D357,894 S 5/1995 Arnold et al.
 5,609,312 A 3/1997 Arlton et al.
 5,628,620 A 5/1997 Arlton
 D388,048 S 12/1997 Taylor et al.
 5,836,545 A 11/1998 Arlton et al.
 5,879,131 A 3/1999 Arlton et al.
 D421,279 S 2/2000 Tsai
 6,032,899 A 3/2000 Mondet et al.
 6,039,541 A * 3/2000 Parker et al. 416/223 R
 D425,853 S 5/2000 Caporaletti
 D467,861 S * 12/2002 Lee D12/326
 6,632,119 B2 10/2003 Chernek et al.
 6,659,721 B1 * 12/2003 Parker et al. 416/5
 6,719,244 B1 4/2004 Gress
 D503,142 S * 3/2005 Rehkemper et al. D12/345
 6,884,034 B1 * 4/2005 Parker et al. 416/1

6,929,215 B2 * 8/2005 Arlton 244/17.11
 D524,229 S * 7/2006 Stille et al. D12/327
 D548,803 S * 8/2007 Zimet D21/442
 2002/0109044 A1 8/2002 Rock
 2004/0087241 A1 5/2004 Agostini et al.
 2005/0121553 A1 6/2005 Isawa et al.
 2006/0231677 A1 10/2006 Zimel et al.
 2007/0012818 A1 1/2007 Miyazawa et al.

FOREIGN PATENT DOCUMENTS

DE 40 17 402 A1 12/1991
 GB 916894 A 1/1963
 GB 1081341 A 8/1967
 JP 2005193905 A 7/2005
 JP 2004121798 A 12/2006

OTHER PUBLICATIONS

Photographic prior art reference #2, helicopter displaying writing in French on tail.
 Photographic prior art reference #3, explanation of the function of a flybar.
 Photographic prior art reference #4, toy helicopter, www.raidentech.com.
 Photographic prior art reference #5, toy helicopter.
 Photographic prior art reference #6, helicopter.
 Photographic prior art reference #7, helicopter with M40297 or MA0297 displayed on tail.
 Photographic prior art reference #8, toy helicopter #AHS-23900, hstoy.en.alibaba.com.
 Photographic prior art reference #9, toy helicopter, toys999.en.alibaba.com.
 Mill, Colin. "Practical Theories, Part 9", W3MH—World Wide Web Model *Helicopter Magazine*, Jul. 1996, <http://www.w3mh.co.uk/articles/html/csm9-11.htm>.
 Day, David. "Moving Swashplates & CCPM", 2001-2006. See <http://www.iroquois.free-online.co.uk>.

* cited by examiner

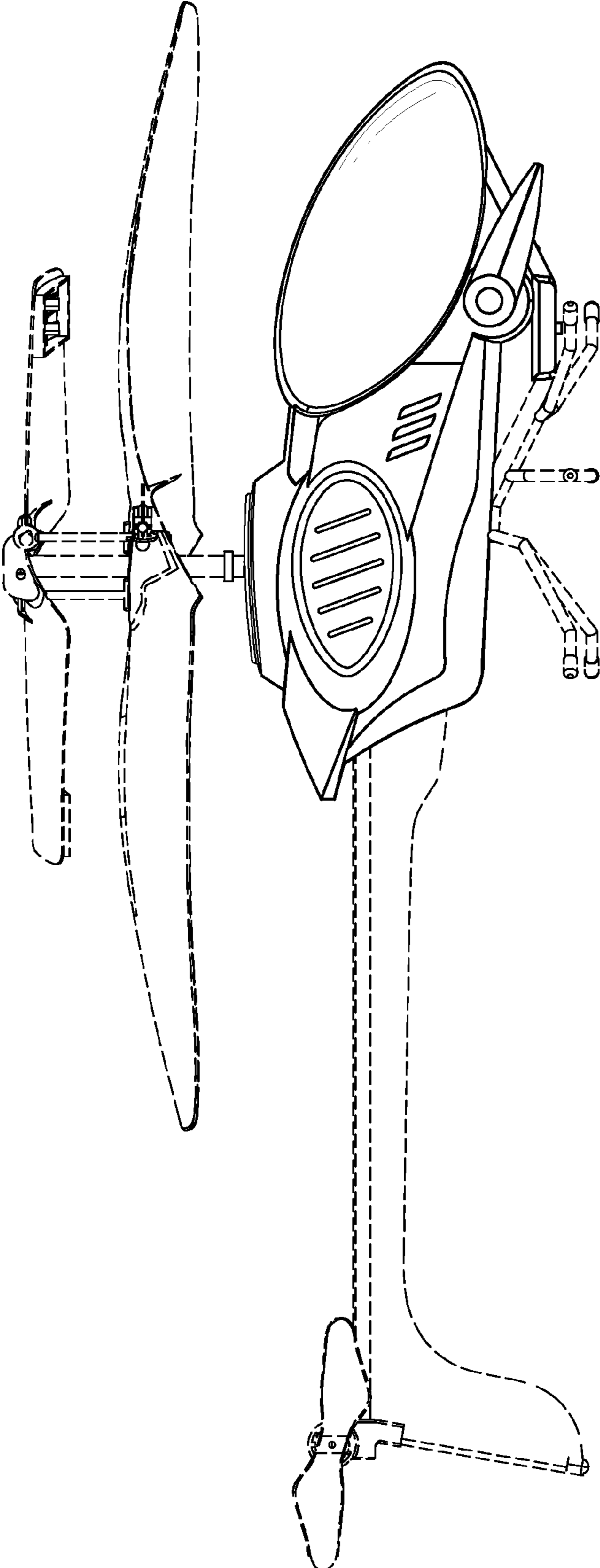

FIG. 1

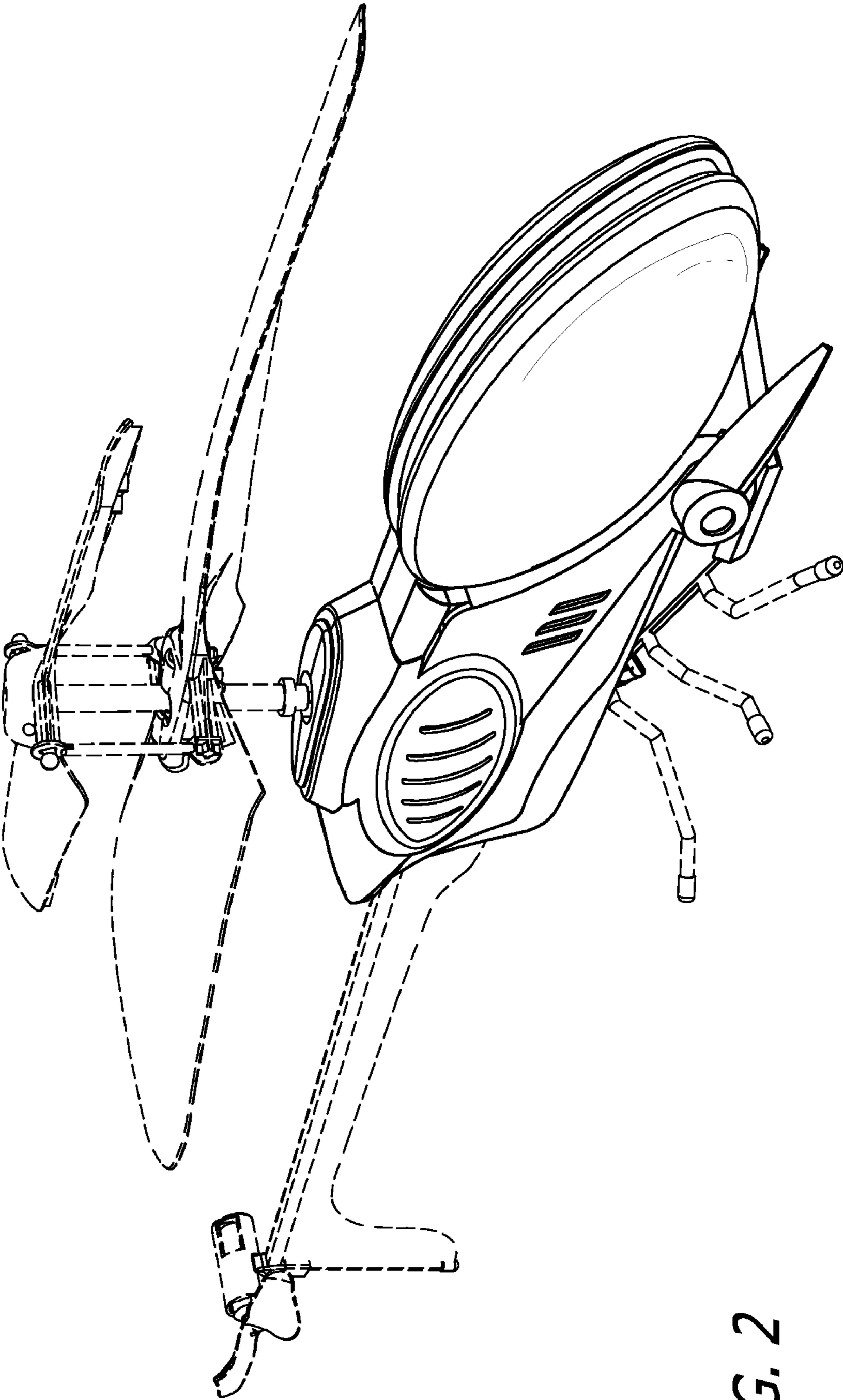

FIG. 2

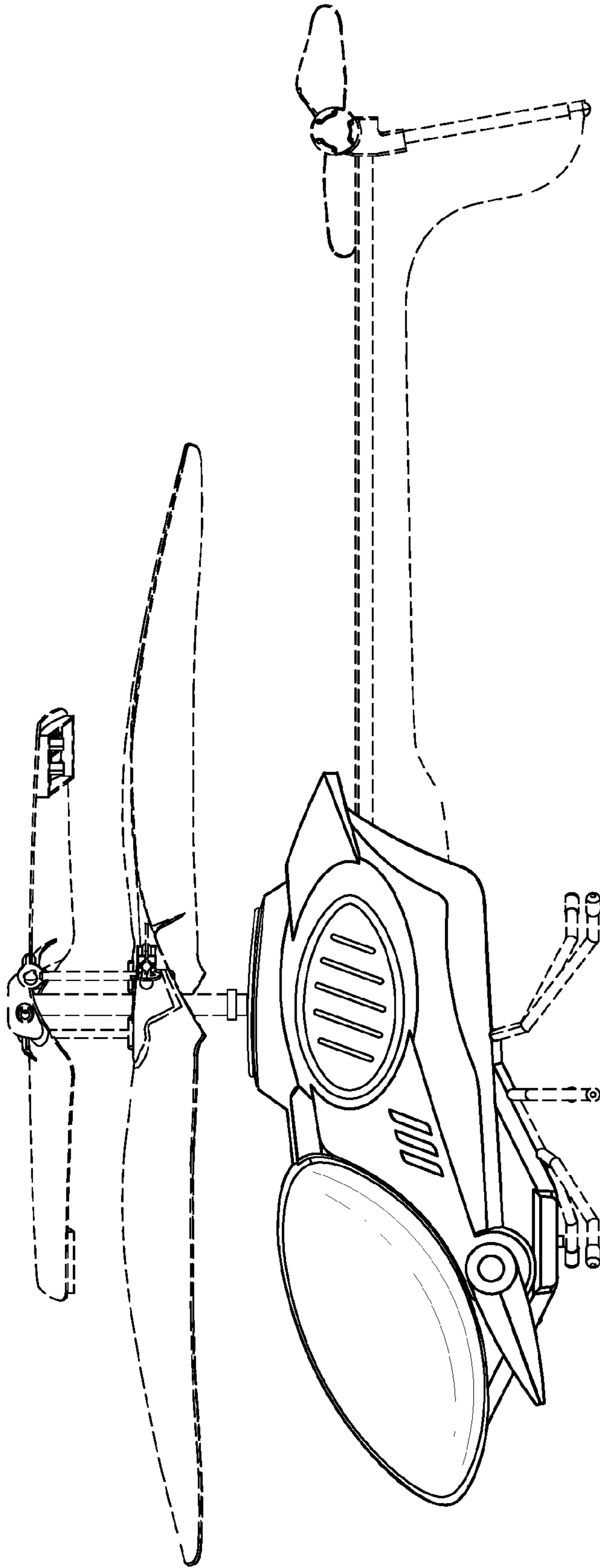

FIG. 3

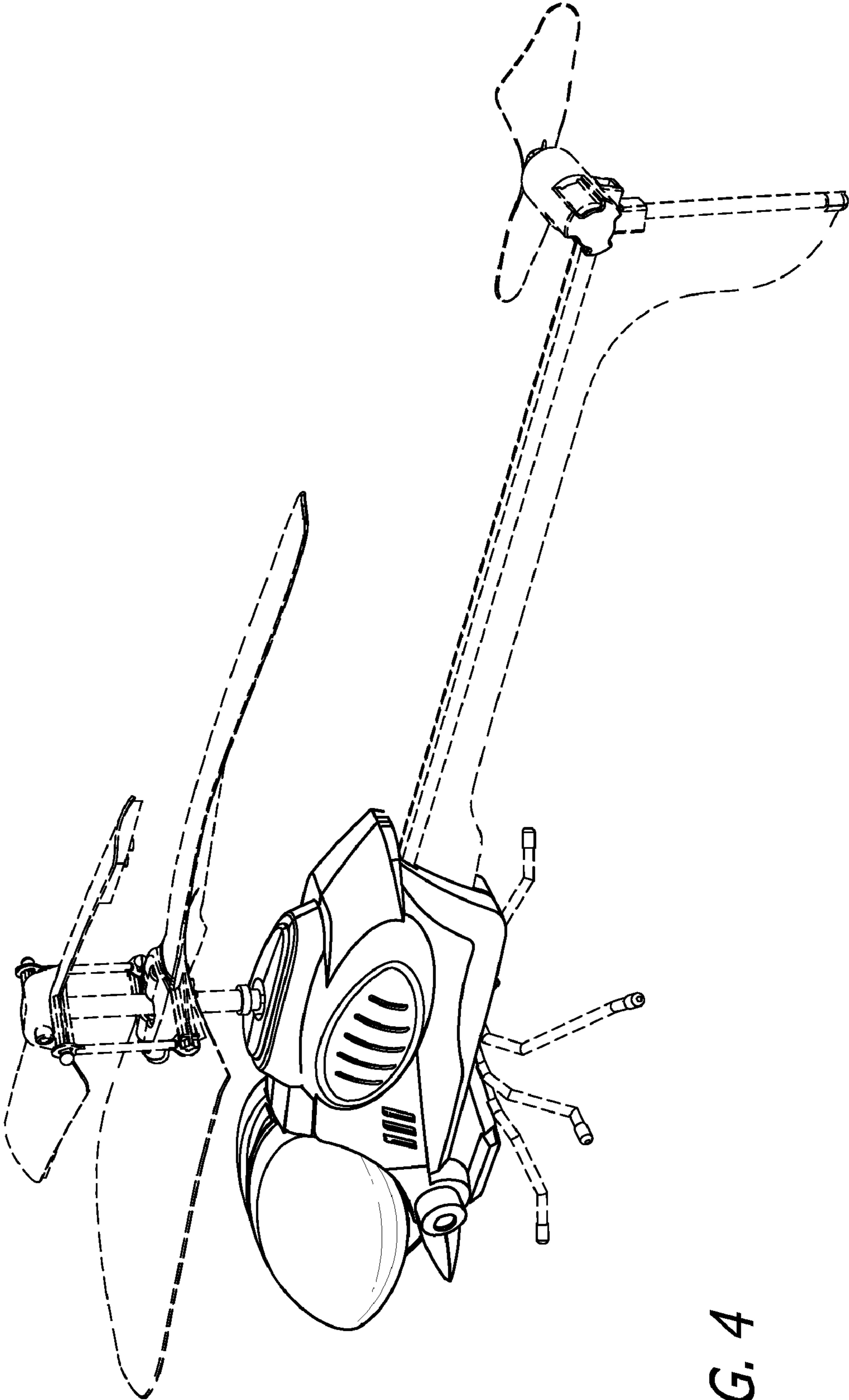

FIG. 4

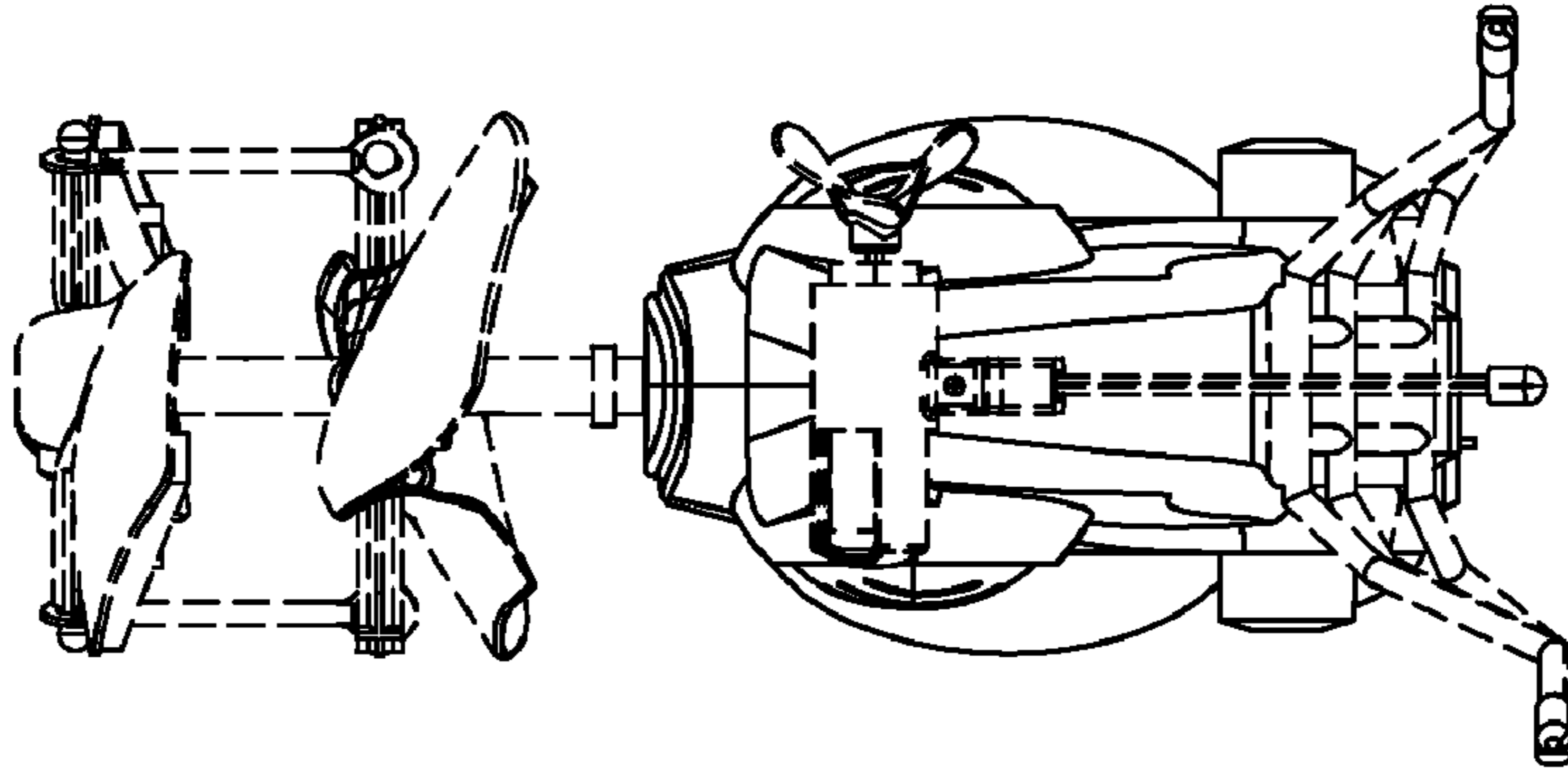

FIG. 5

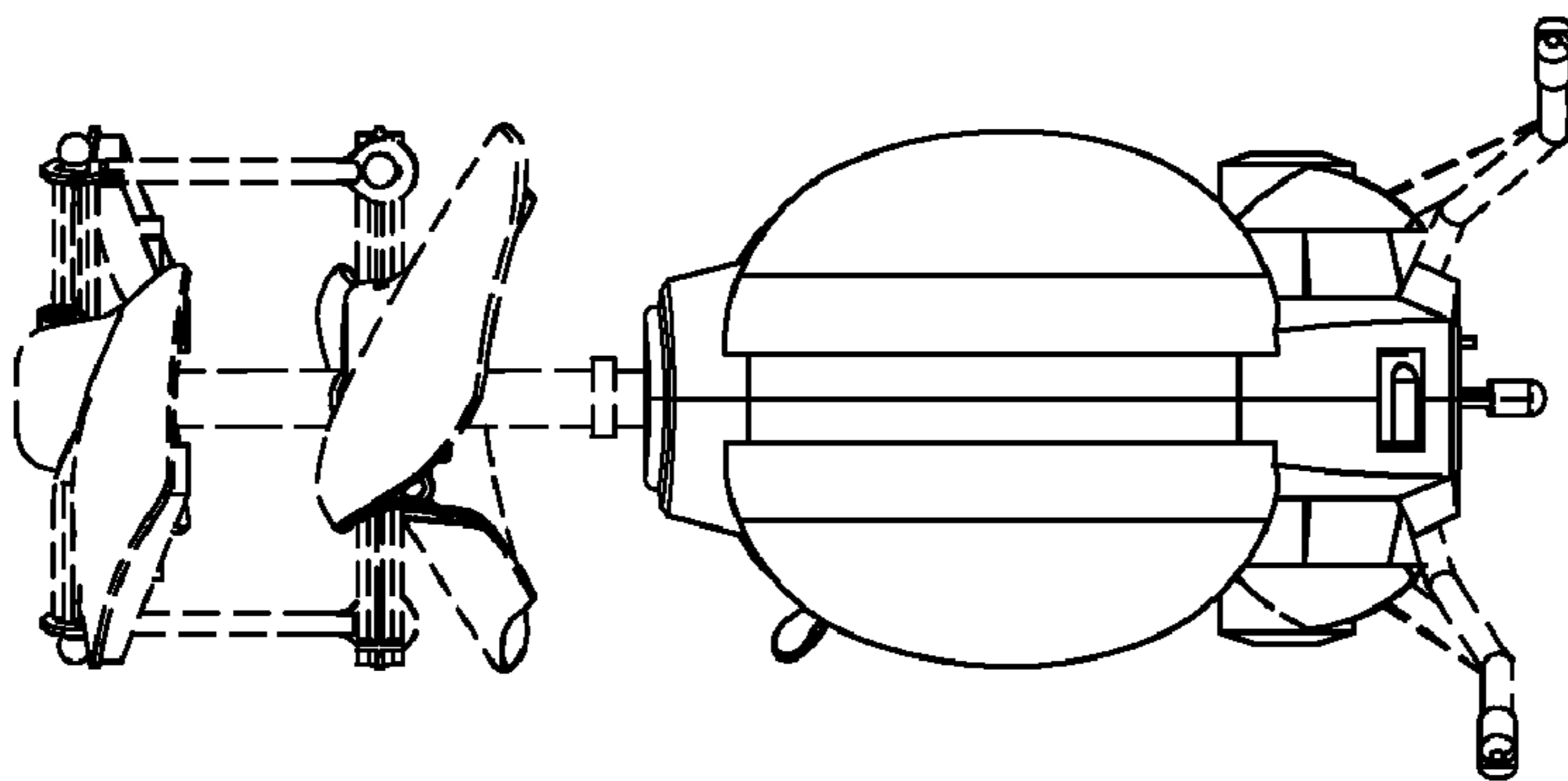

FIG. 6