



US00D561575S

(12) **United States Design Patent**
Nishide et al.

(10) **Patent No.:** **US D561,575 S**

(45) **Date of Patent:** **** Feb. 12, 2008**

(54) **TANDEM TYPE ROD END**

(75) Inventors: **Tetsuhiro Nishide**, Tokyo (JP);
Toshihisa Sakamoto, Tokyo (JP)

(73) Assignee: **THK Co., Ltd**, Tokyo (JP)

(**) Term: **14 Years**

(21) Appl. No.: **29/274,120**

(22) Filed: **Mar. 29, 2007**

(30) **Foreign Application Priority Data**

Sep. 29, 2006 (JP) 2006-026387

(51) **LOC (8) Cl.** **08-09**

(52) **U.S. Cl.** **D8/400**

(58) **Field of Classification Search** D8/400,
D8/499; D12/174, 179-180, 100, 111, 114;
D15/3, 143, 138; 188/266.1, 266.2, 281,
188/284, 290, 306, 308, 310; 280/271, 272,
280/270, 276

See application file for complete search history.

(56) **References Cited**

U.S. PATENT DOCUMENTS

2,478,660 A * 8/1949 Keahey 384/211

D443,285 S * 6/2001 Sasaki et al. D15/143
D447,157 S * 8/2001 Sasaki et al. D15/143
2005/0087969 A1 * 4/2005 Okazaki et al. 280/771

* cited by examiner

Primary Examiner—Cathron Brooks

Assistant Examiner—Barbara Fox

(74) *Attorney, Agent, or Firm*—Young & Thompson

(57) **CLAIM**

The ornamental design for a tandem type rod end, as shown and described.

DESCRIPTION

FIG. 1 is a front elevational view of a tandem type rod end, showing our new design;

FIG. 2 is a rear elevational view thereof;

FIG. 3 is a top plan view thereof;

FIG. 4 is a bottom plan view thereof;

FIG. 5 is a left side view thereof;

FIG. 6 is a right side view thereof; and,

FIG. 7 is a perspective view thereof.

This article is related to a tandem type rod end that constitutes a steering damper for a vehicle.

1 Claim, 4 Drawing Sheets

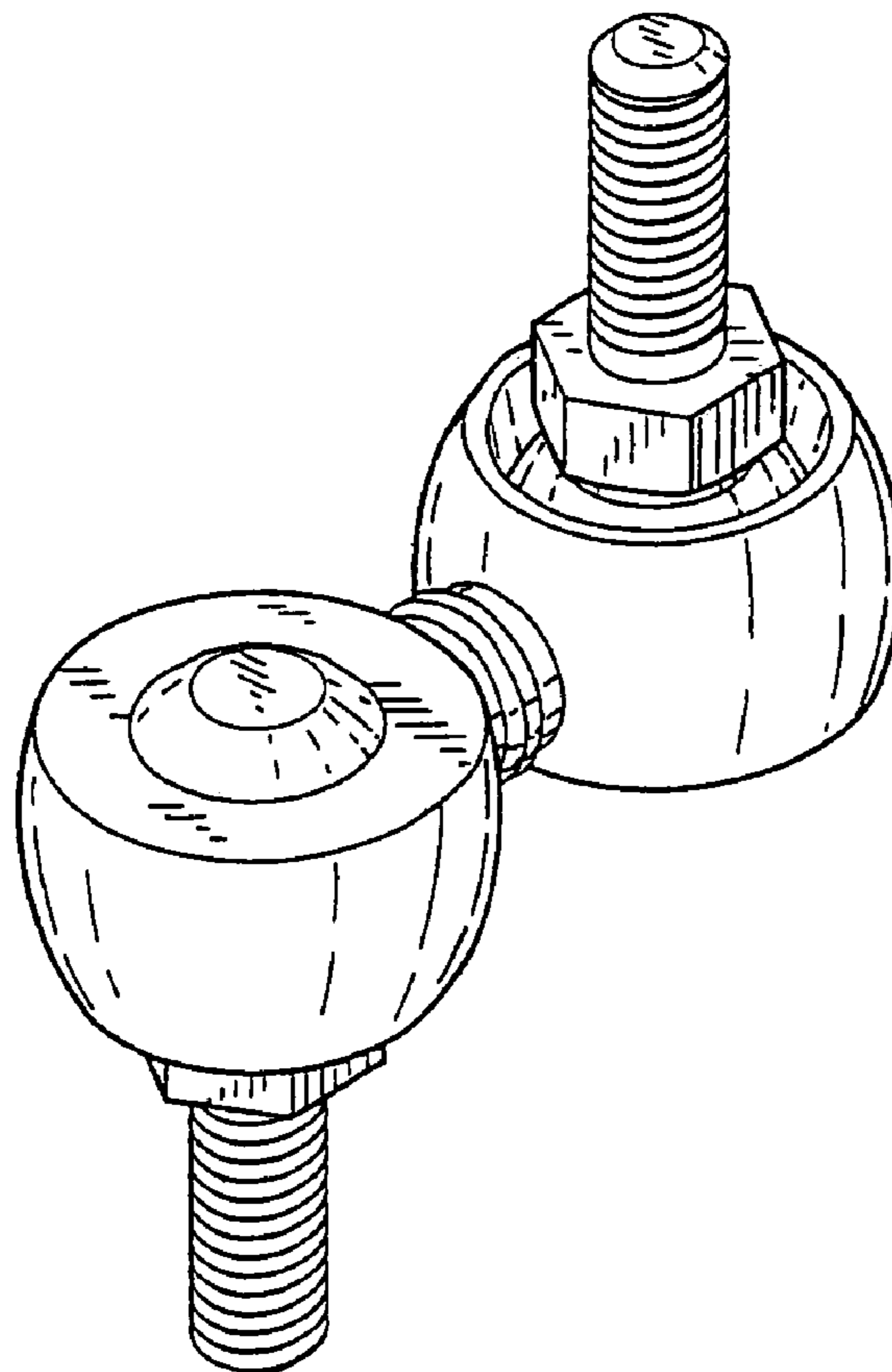

FIG.1

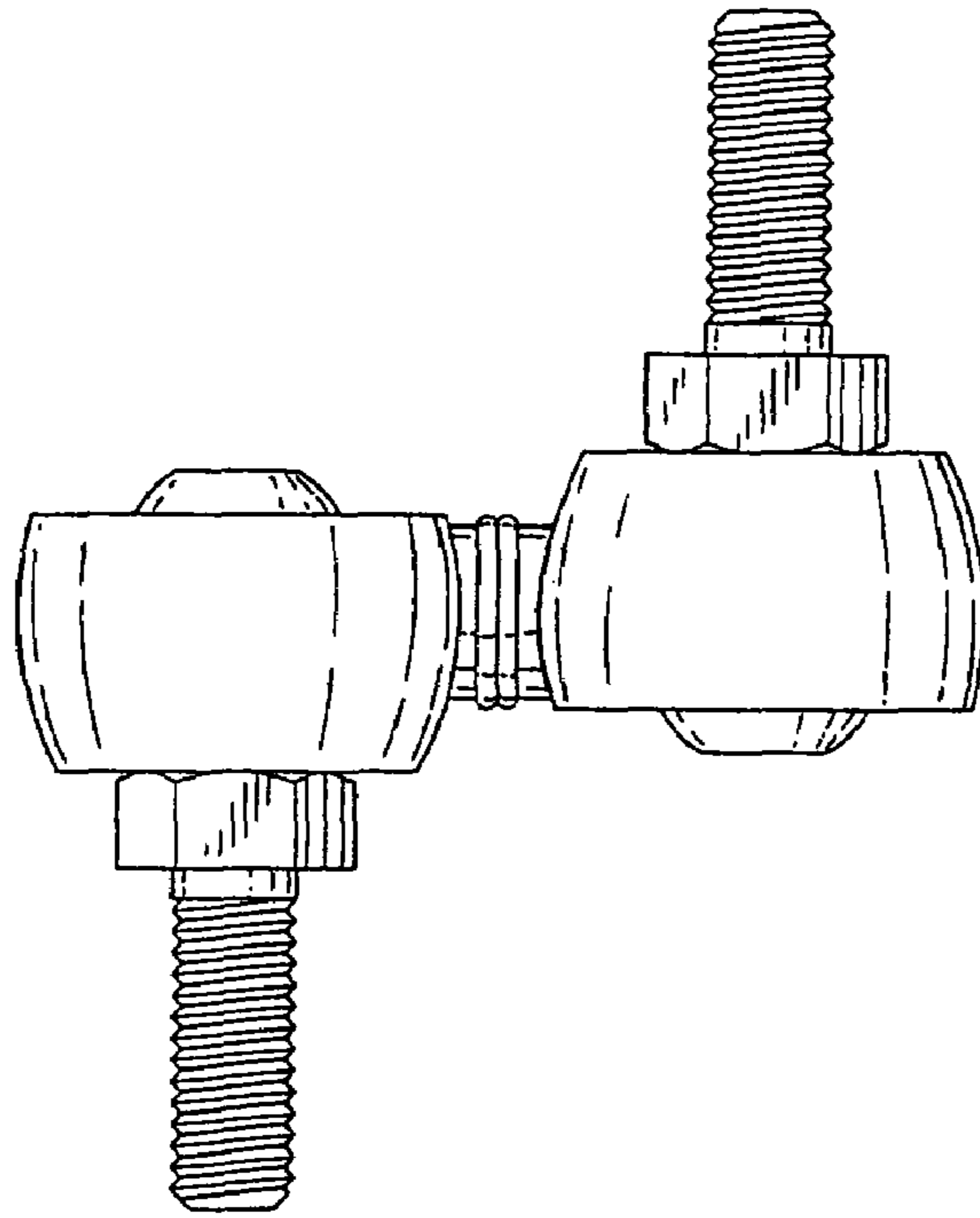

FIG.2

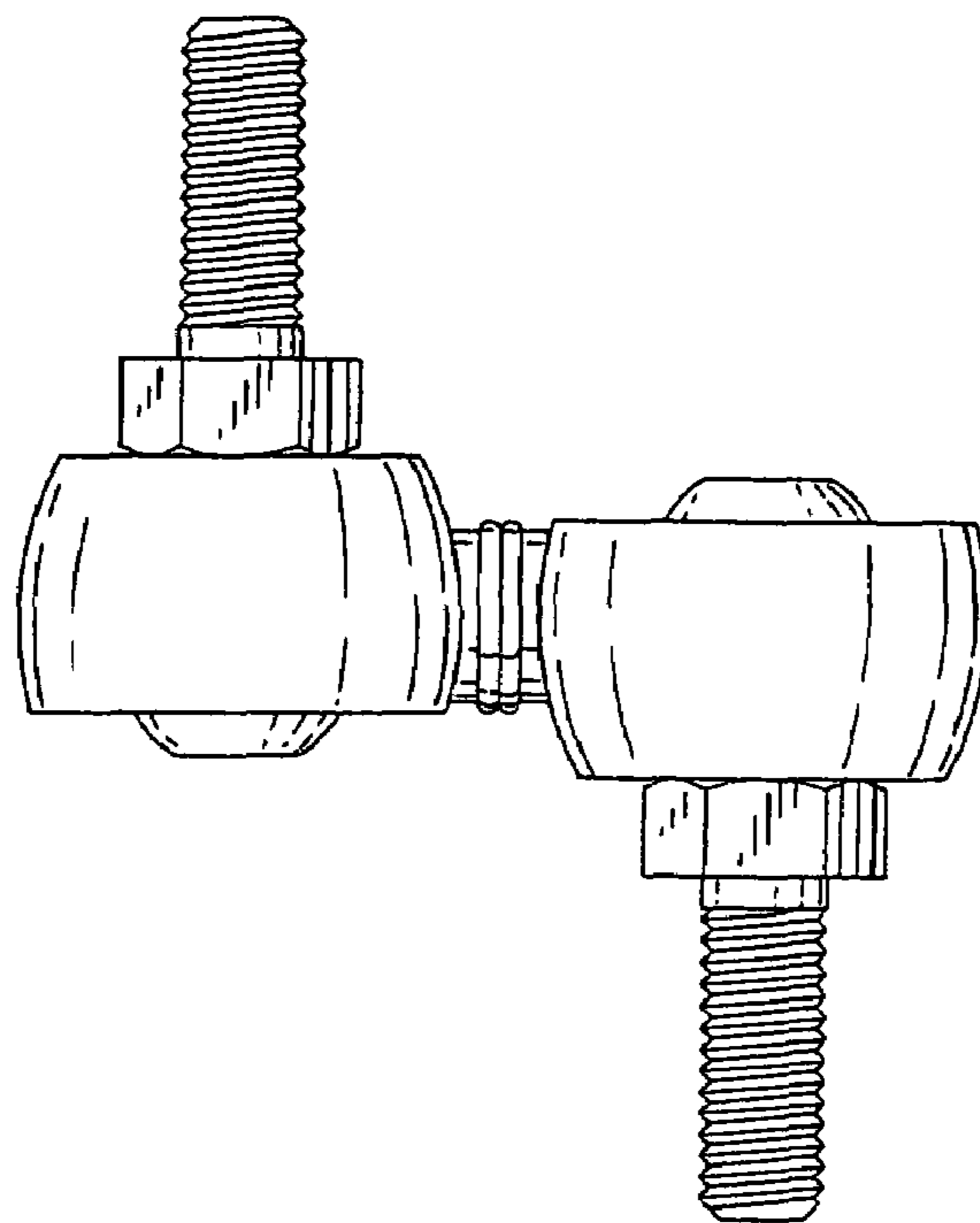

FIG.3

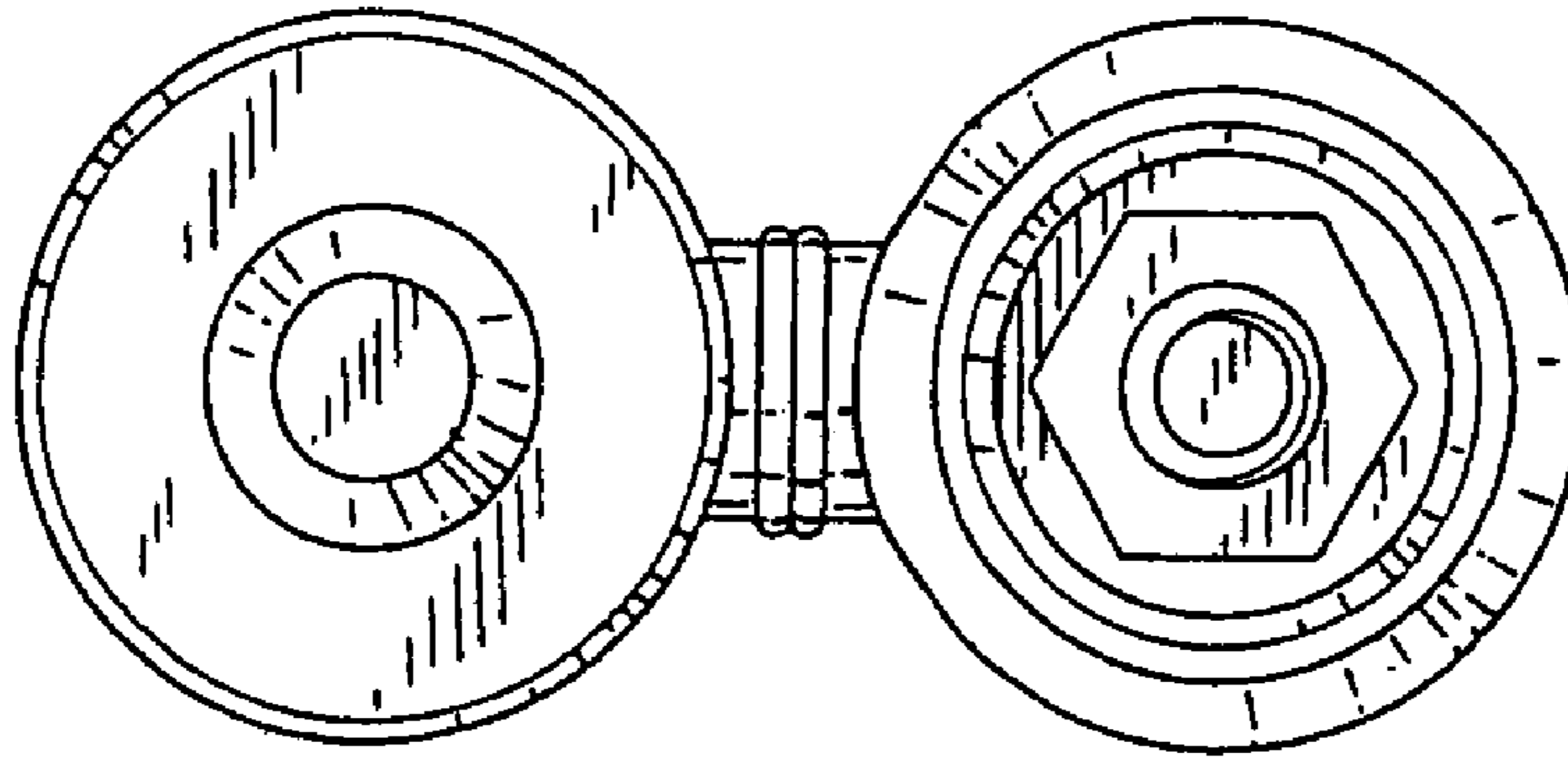

FIG.4

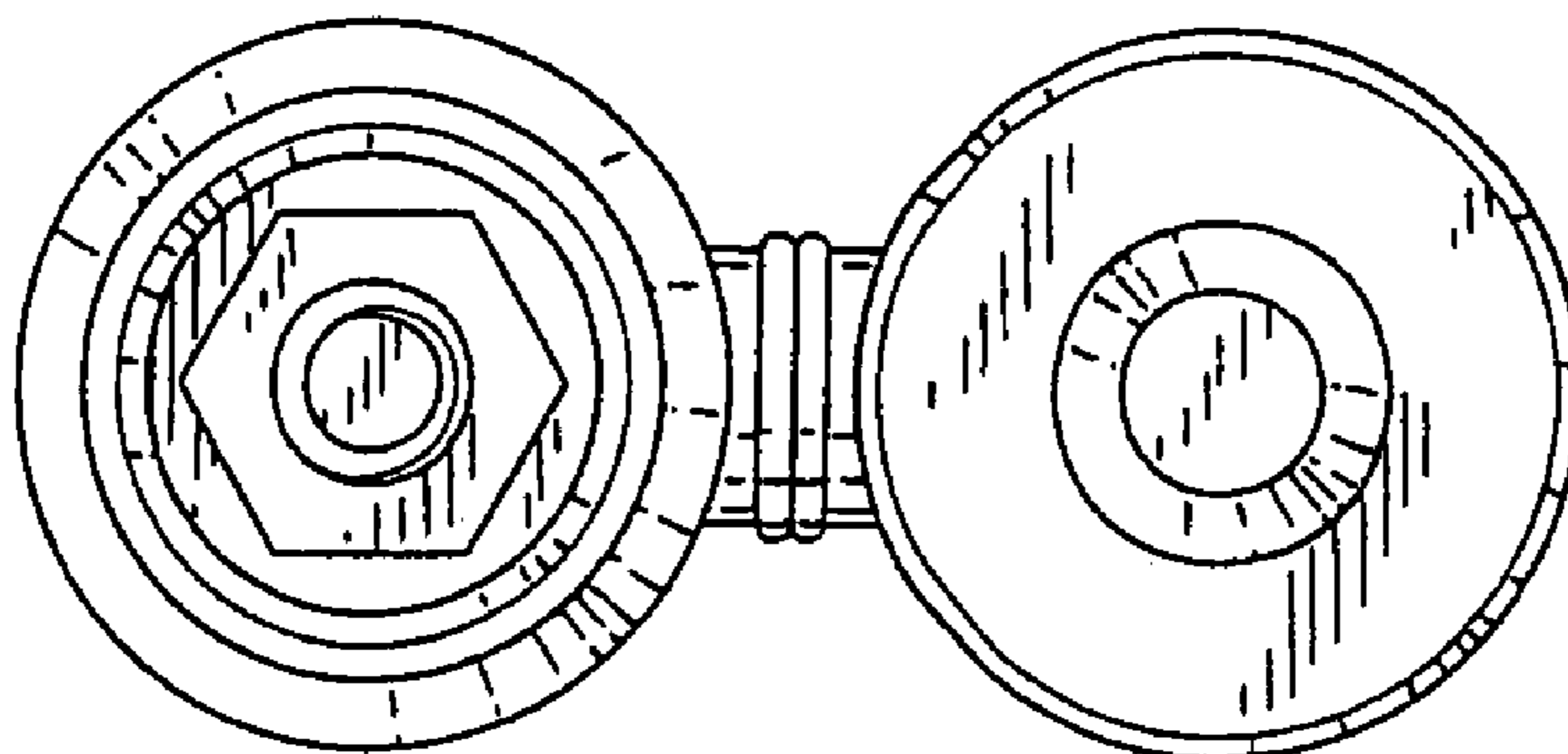

FIG.5

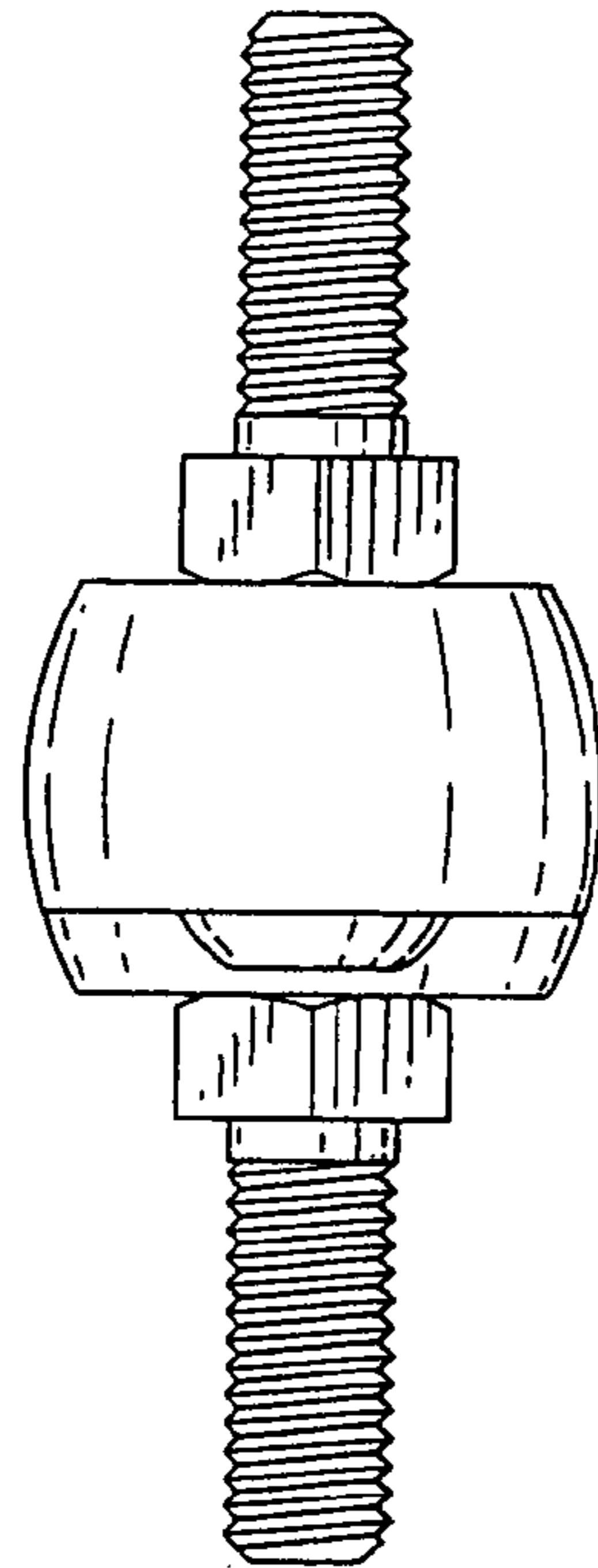

FIG.6

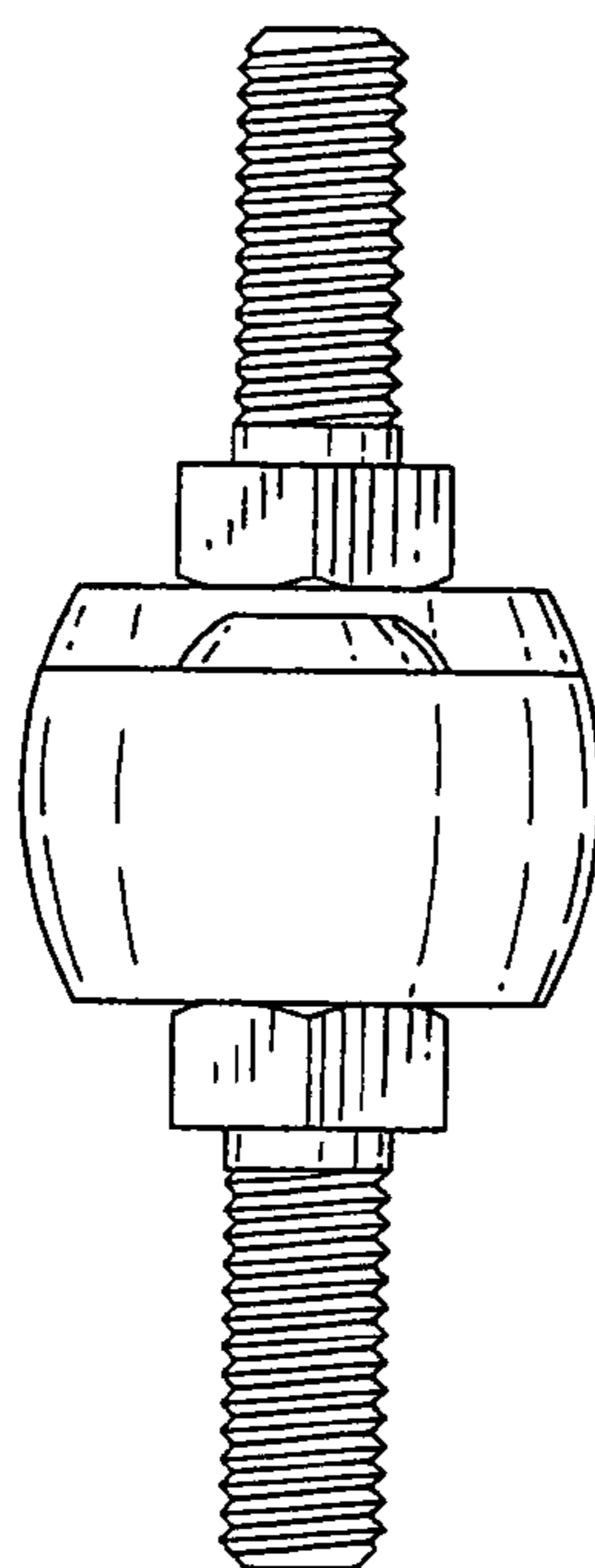

FIG. 7

