



US00D561486S

(12) **United States Design Patent**  
**Ricci**

(10) **Patent No.:** **US D561,486 S**

(45) **Date of Patent:** **\*\* Feb. 12, 2008**

(54) **SEAT**

(75) Inventor: **Luca Ricci**, Bertinoro-Fc (IT)

(73) Assignee: **DeCoro Limited**, Hong Kong (HK)

(\*\*) Term: **14 Years**

(21) Appl. No.: **29/256,301**

(22) Filed: **Mar. 17, 2006**

(30) **Foreign Application Priority Data**

Nov. 18, 2005 (CN) ..... 2005 3 0147648

(51) **LOC (8) Cl.** ..... **06-01**

(52) **U.S. Cl.** ..... **D6/381**

(58) **Field of Classification Search** ..... D6/334-336,  
D6/371, 381, 500-502, 349, 369, 370, 372,  
D6/376, 379, 380; 297/232, 445.1, 451.3,  
297/451.9; 5/12.1

See application file for complete search history.

(56) **References Cited**

**U.S. PATENT DOCUMENTS**

D392,809 S *	3/1998	Natuzzi et al.	.....	D6/381
D393,377 S *	4/1998	Nicoletti	.....	D6/381
D399,362 S *	10/1998	Natuzzi et al.	.....	D6/381
D447,883 S *	9/2001	Meier et al.	.....	D6/381
D469,264 S *	1/2003	Natuzzi et al.	.....	D6/334
D470,326 S *	2/2003	Ricci	.....	D6/381
D470,676 S *	2/2003	Ricci	.....	D6/381
D474,910 S *	5/2003	Ricci	.....	D6/381
D483,196 S *	12/2003	Ricci	.....	D6/381
D495,159 S *	8/2004	Ricci	.....	D6/381
D495,889 S *	9/2004	Ricci	.....	D6/334
D509,674 S *	9/2005	Ricci	.....	D6/381
D520,773 S *	5/2006	Natuzzi	.....	D6/381
D528,321 S *	9/2006	Adair et al.	.....	D6/381

**OTHER PUBLICATIONS**

Natuzzi sofa #1512, International Home Furnishings Market, High Point, NC, Oct. 1996, 2 pgs.\*

Natuzzi sofa #1585, International Home Furnishings Market, High Point, NC, Apr. 1997, 2 pgs.\*

Natuzzi sofa #1590, International Home Furnishings Market, High Point, NC, Apr. 1997, 2 pgs.\*

Natuzzi sofa #9522, International Home Furnishings Market, High Point, NC, Sep. 1999, 1 pg.\*

Natuzzi sofa #9284, International Home Furnishings Market, High Point, NC, Apr. 1999, 1 pg.\*

\* cited by examiner

*Primary Examiner*—Sandra Snapp

(74) *Attorney, Agent, or Firm*—Ropes & Gray LLP

(57) **CLAIM**

I claim the ornamental design for a seat, as shown and described.

**DESCRIPTION**

FIG. 1 is a front view of one embodiment of my new seat design in the form of a sofa.

FIG. 2 is a side view of this embodiment of the seat.

FIG. 3 is a perspective view of this embodiment of the seat.

FIG. 4 is a rear view of this embodiment of the seat.

FIG. 5 is a side view of this embodiment of the seat.

FIG. 6 is a top view of this embodiment of the seat.

FIG. 7 is a front view of a further embodiment of my new seat design in the form of a chair.

FIG. 8 is a side view of this further embodiment of the seat.

FIG. 9 is a perspective view of this further embodiment of the seat.

FIG. 10 is a rear view of this further embodiment of the seat.

FIG. 11 is a side view of this further embodiment of the seat; and,

FIG. 12 is a top view of this further embodiment of the seat.

As shown in the drawings herein, broken (dotted) lines are used to indicate stitching.

**1 Claim, 12 Drawing Sheets**

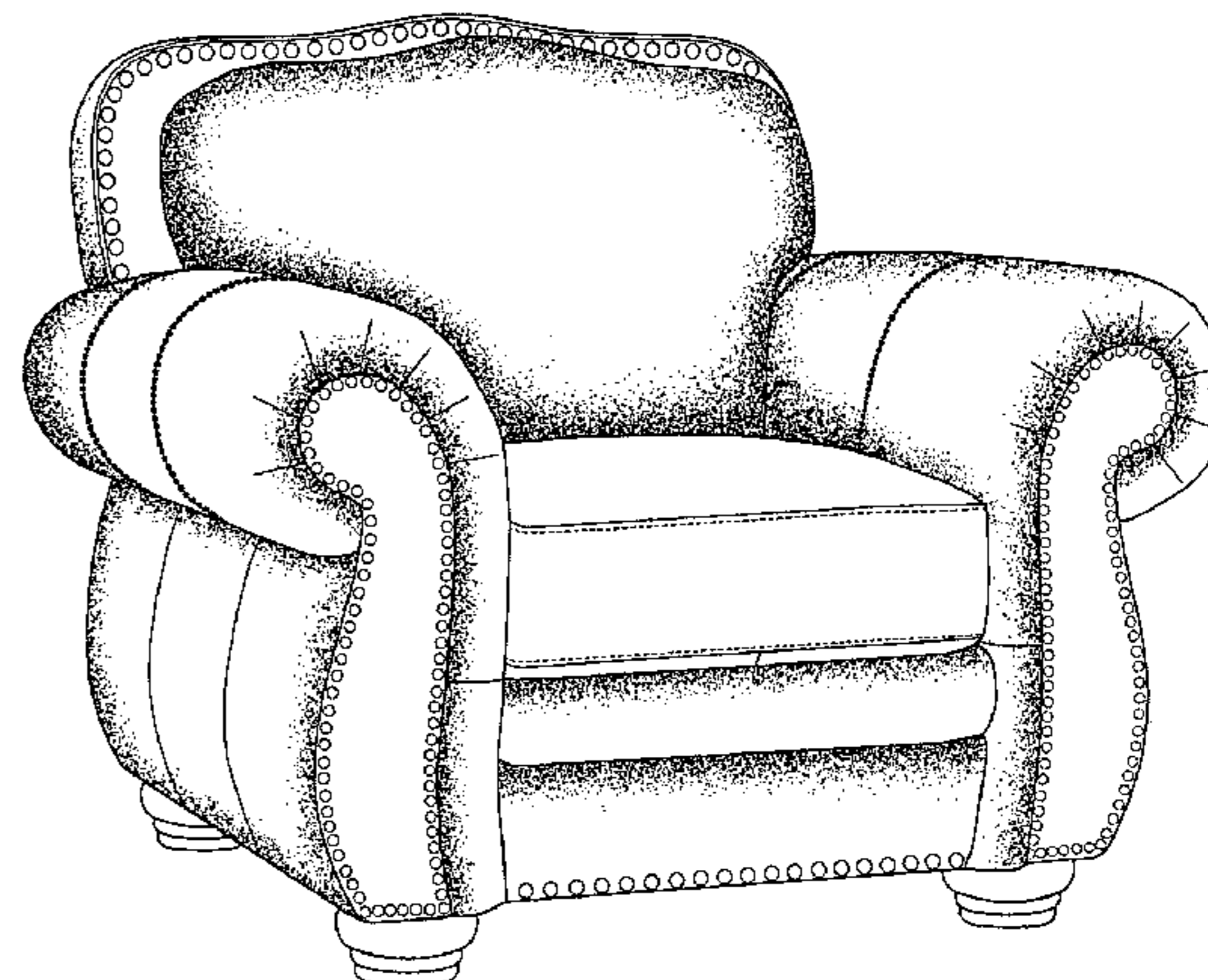
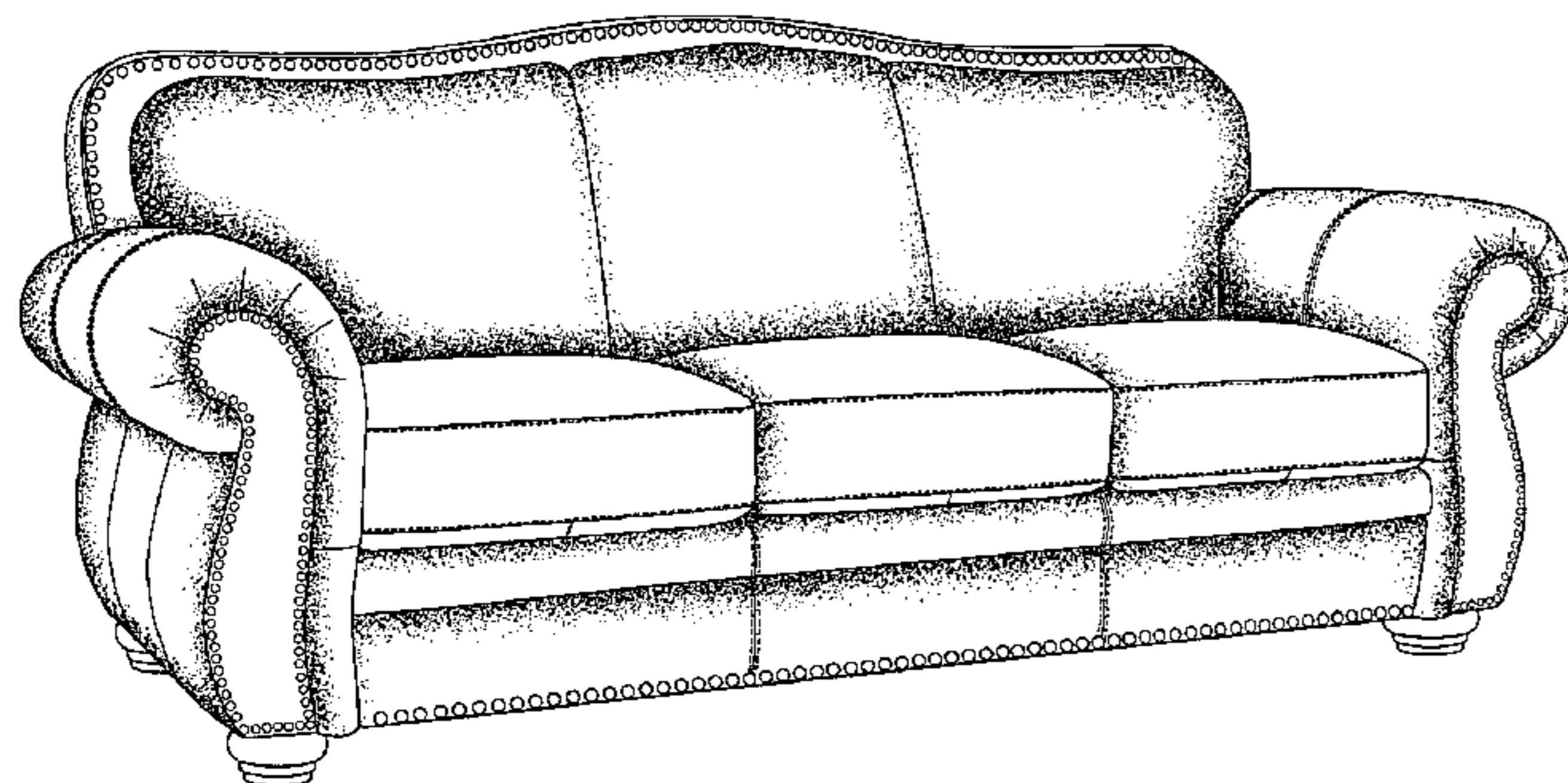

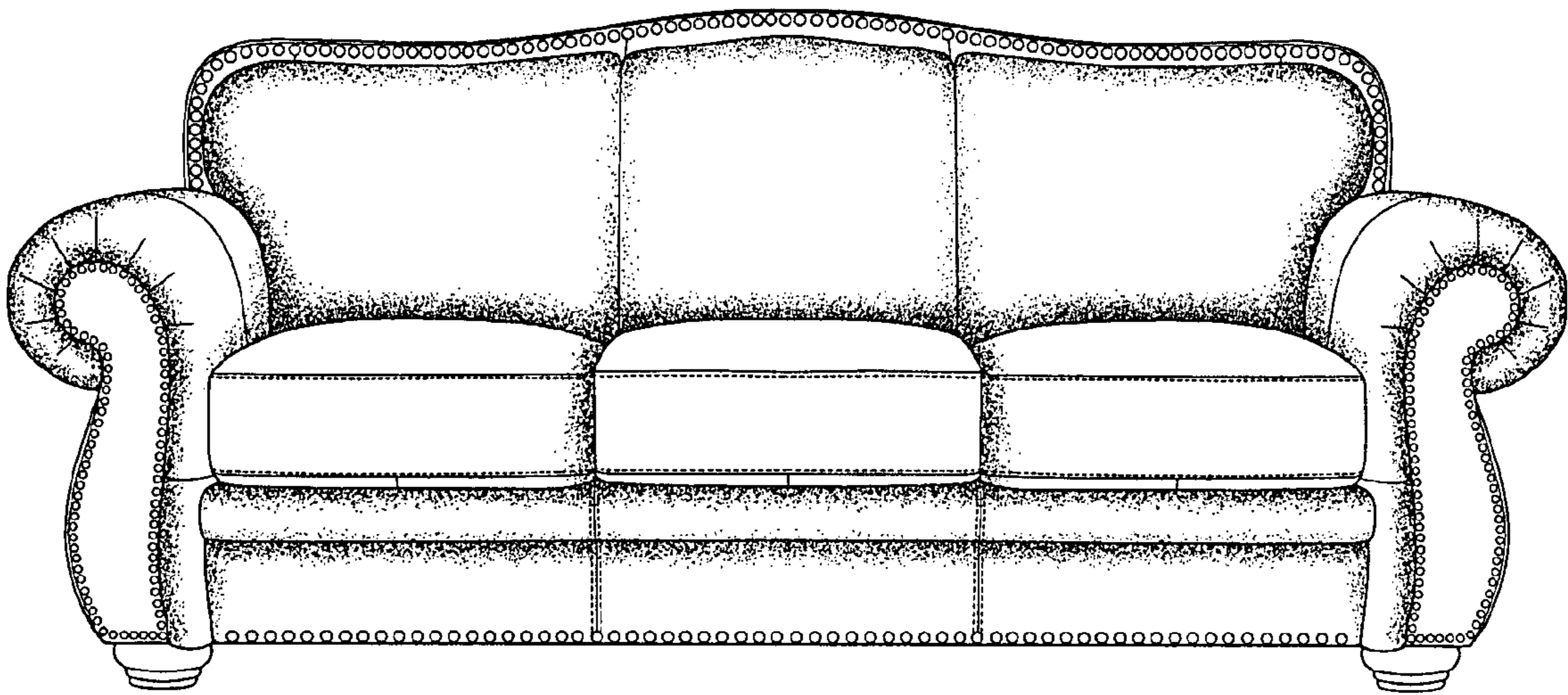

FIGURE 1



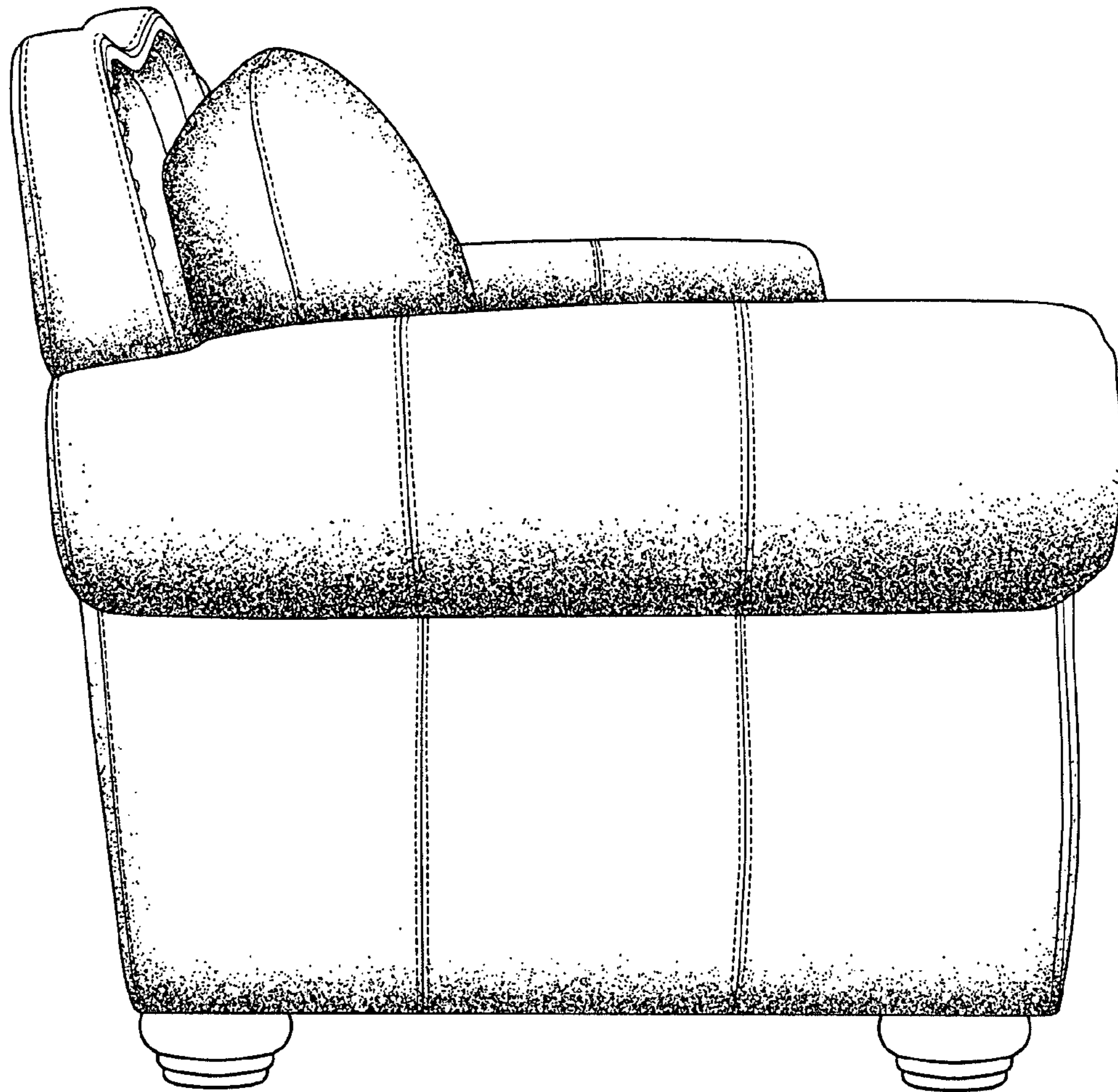

FIGURE 2

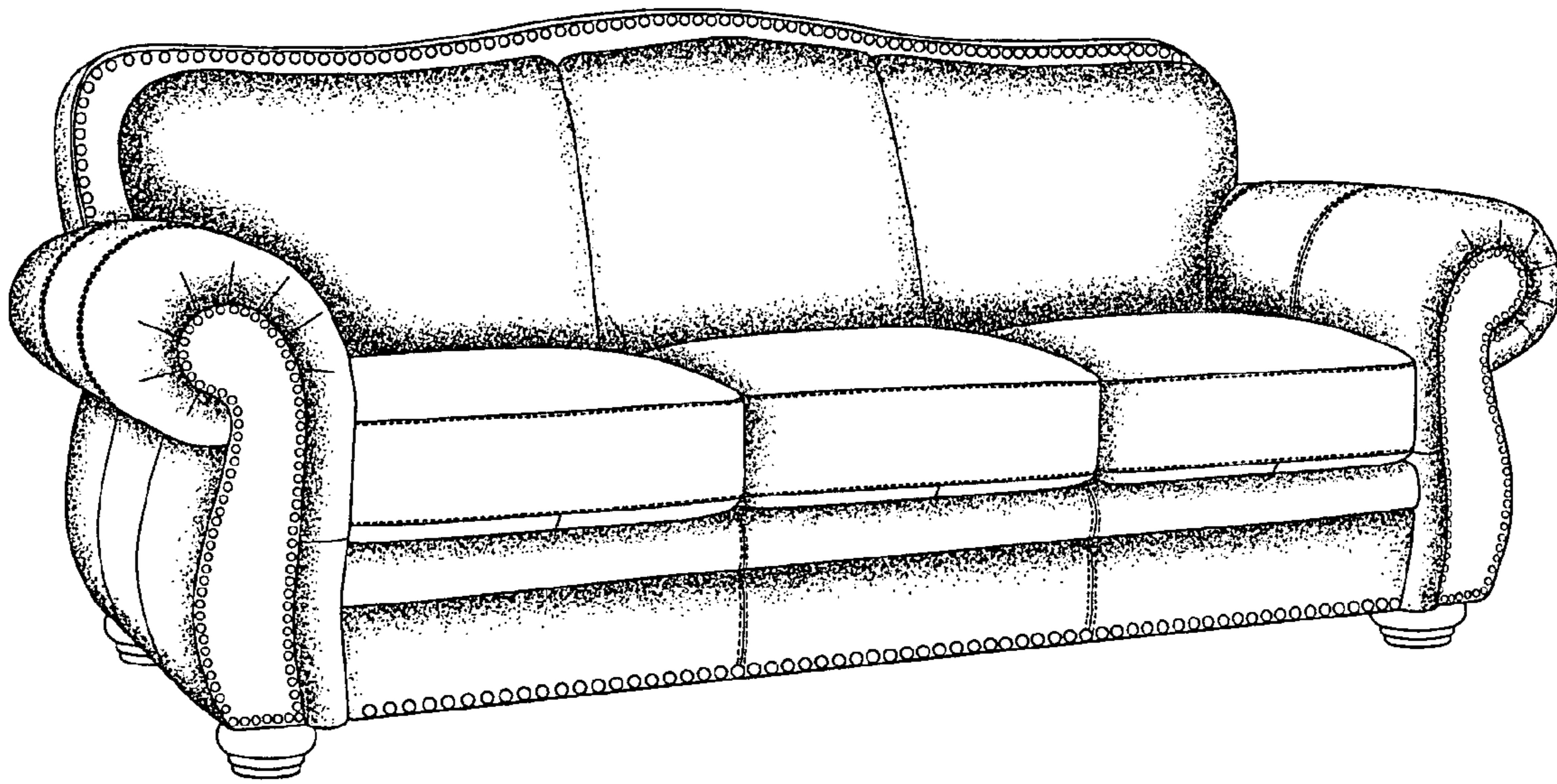

FIGURE 3

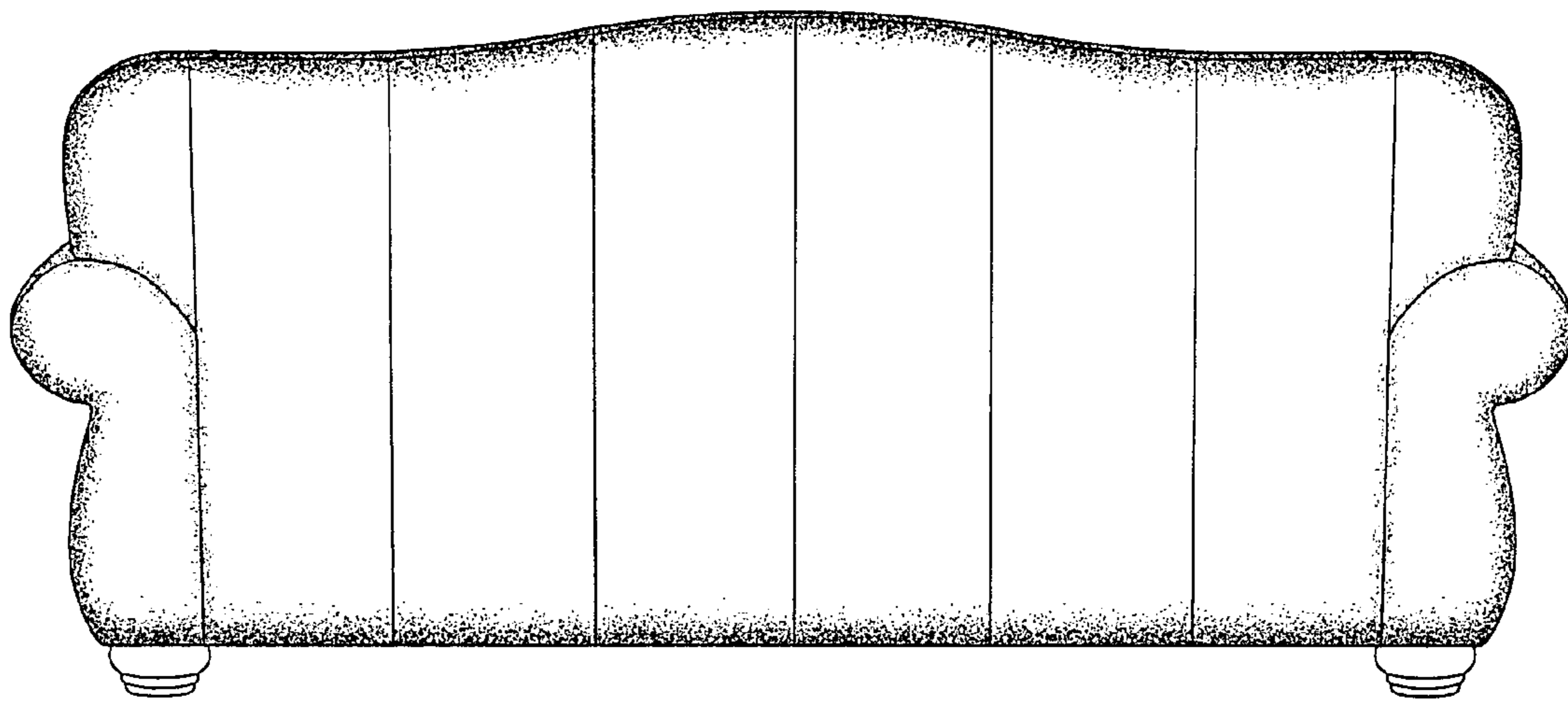

FIGURE 4

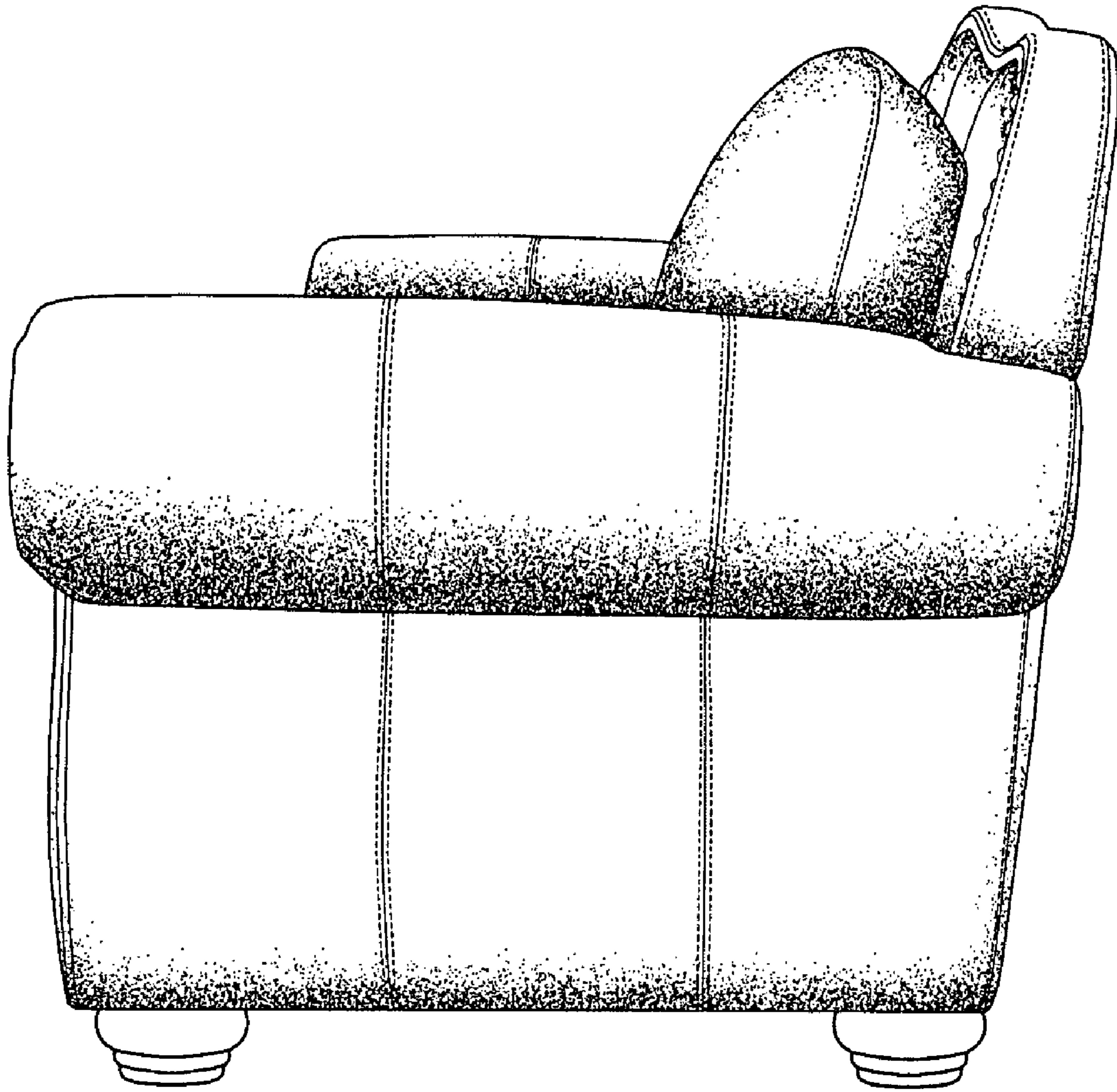

FIGURE 5



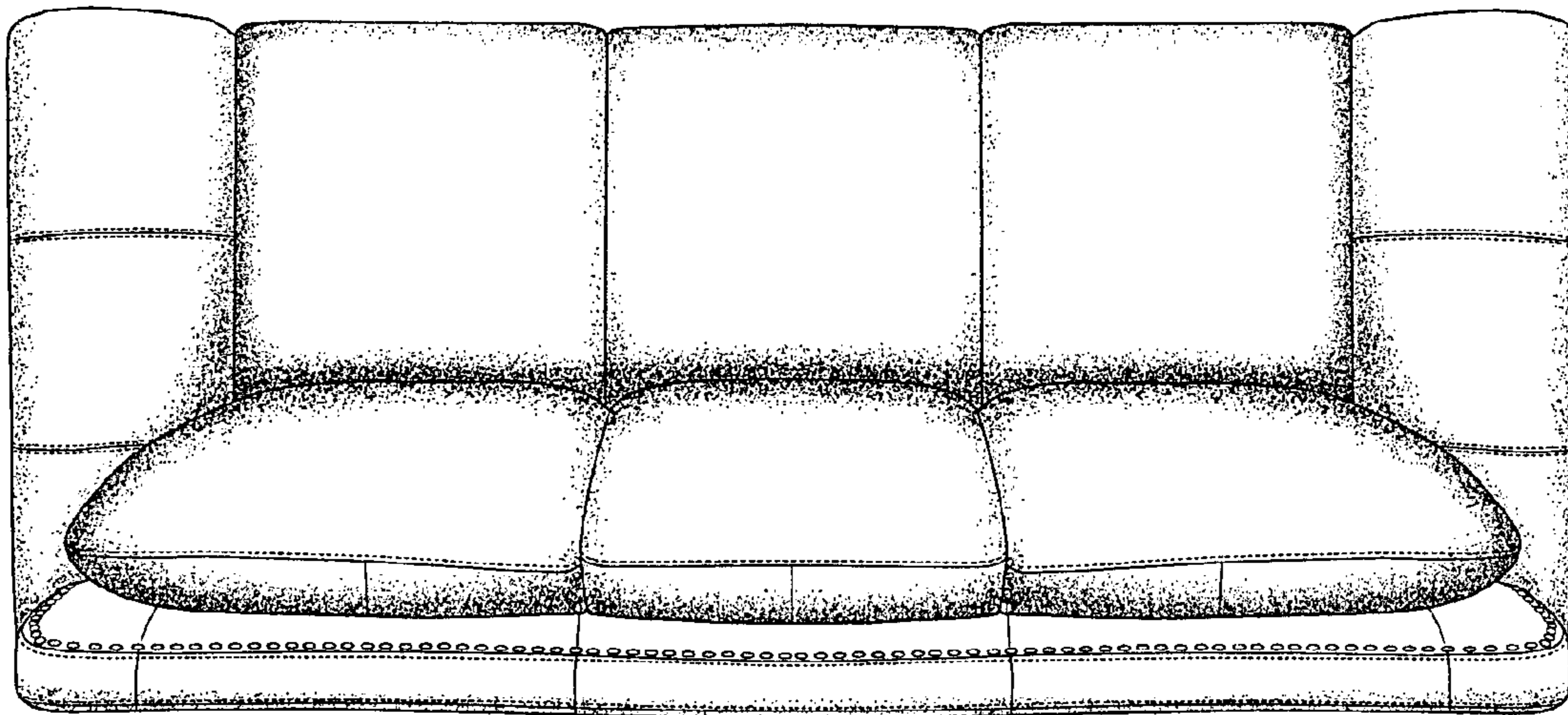

FIGURE 6

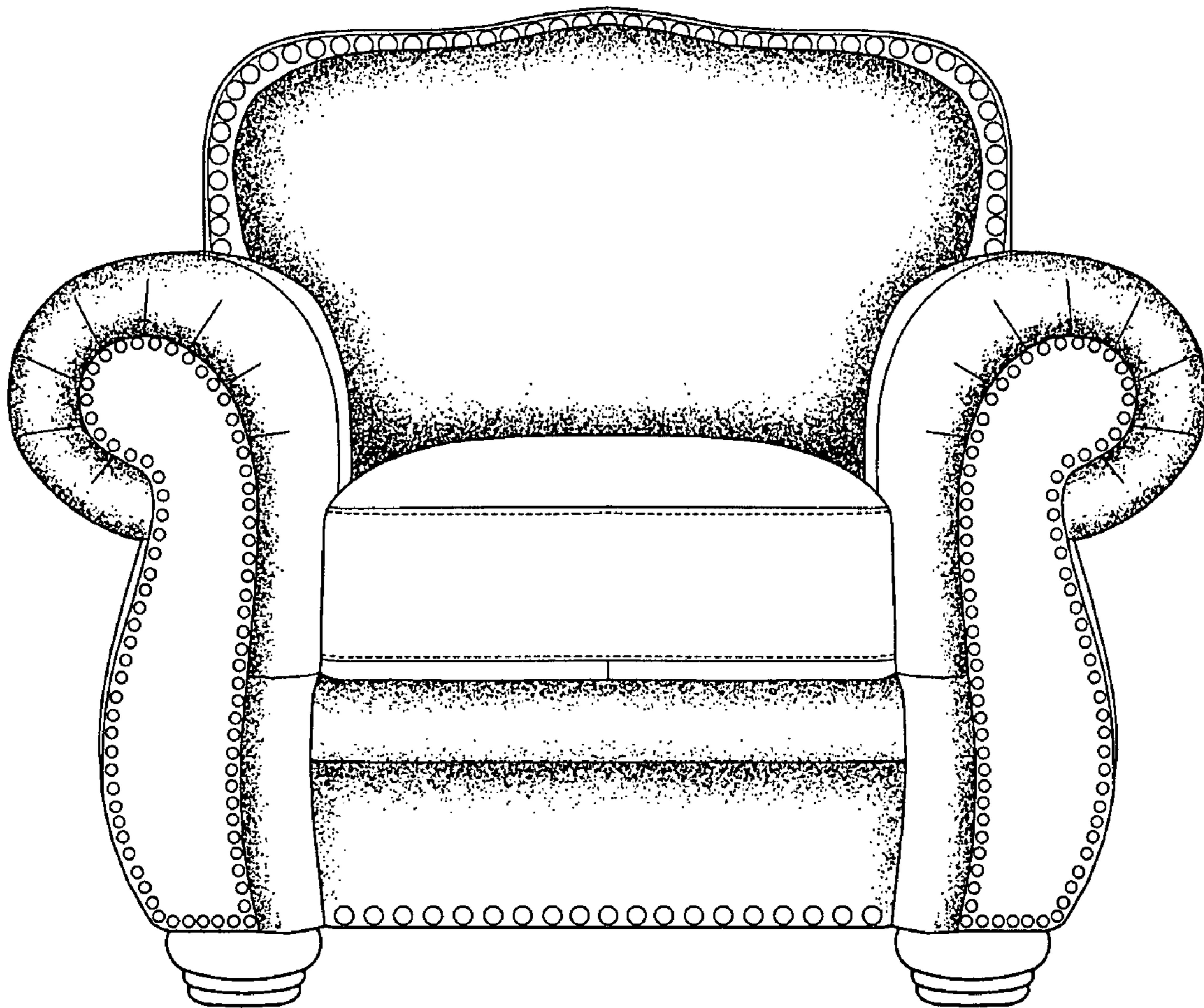

FIGURE 7



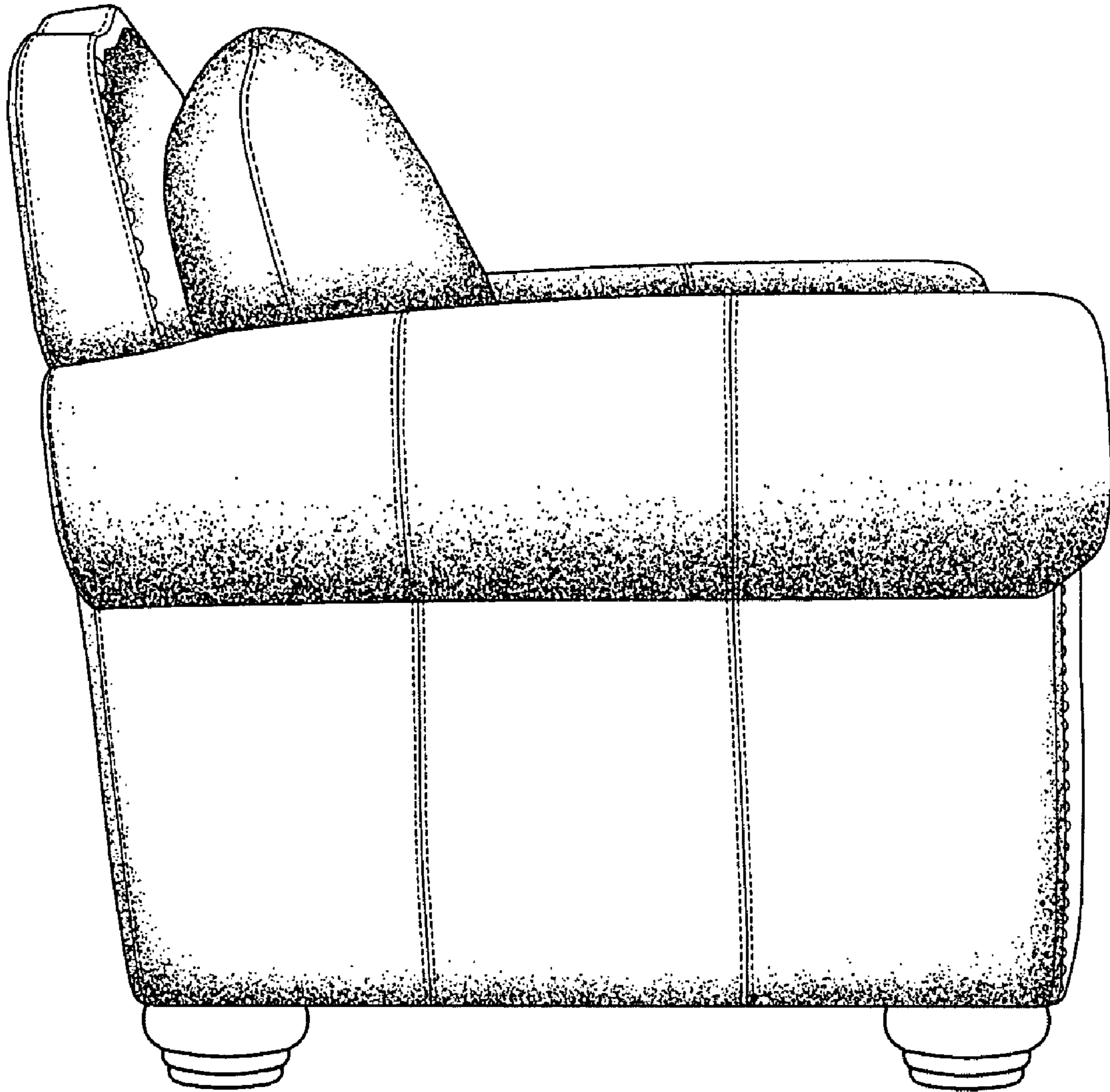

FIGURE 8

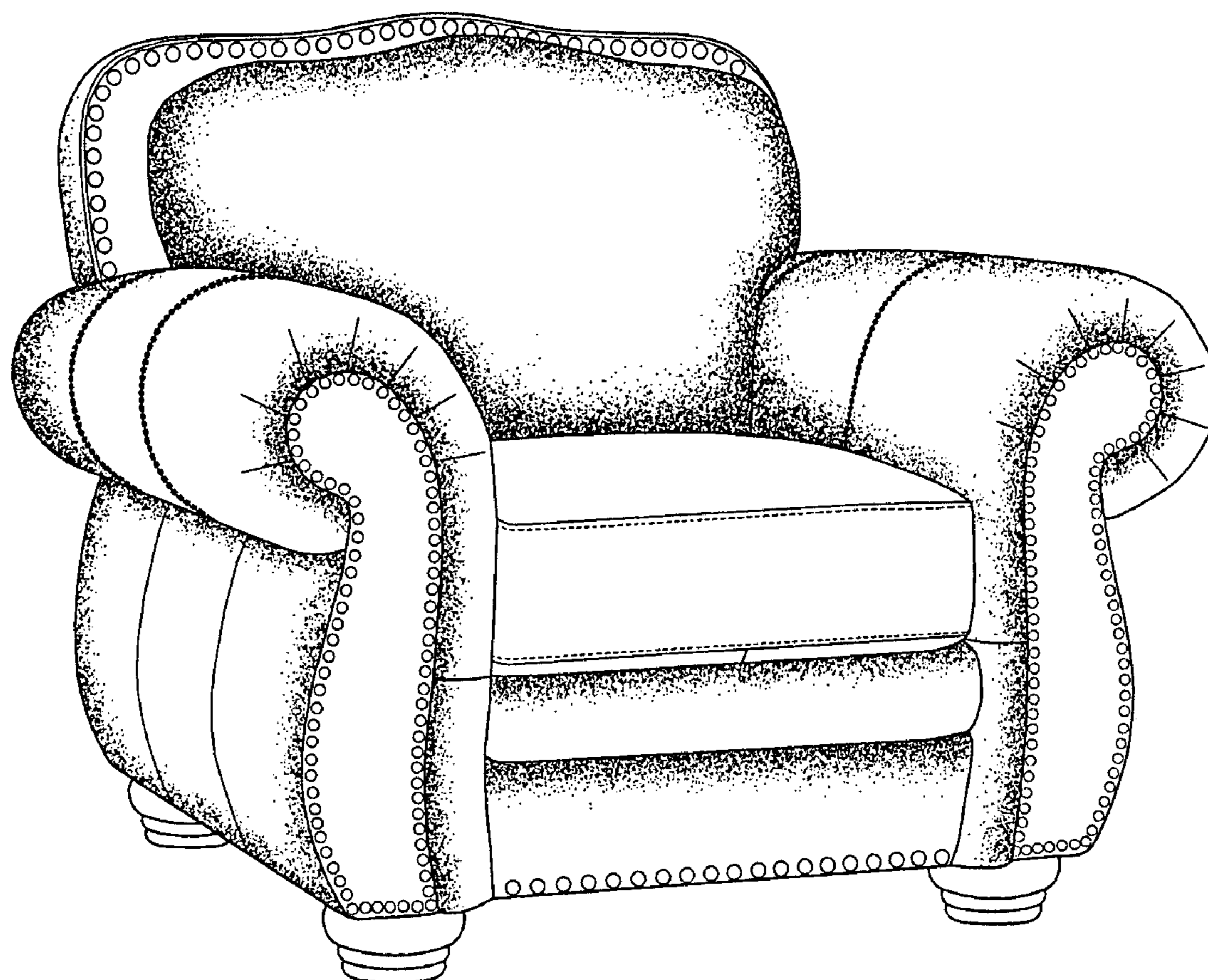

FIGURE 9

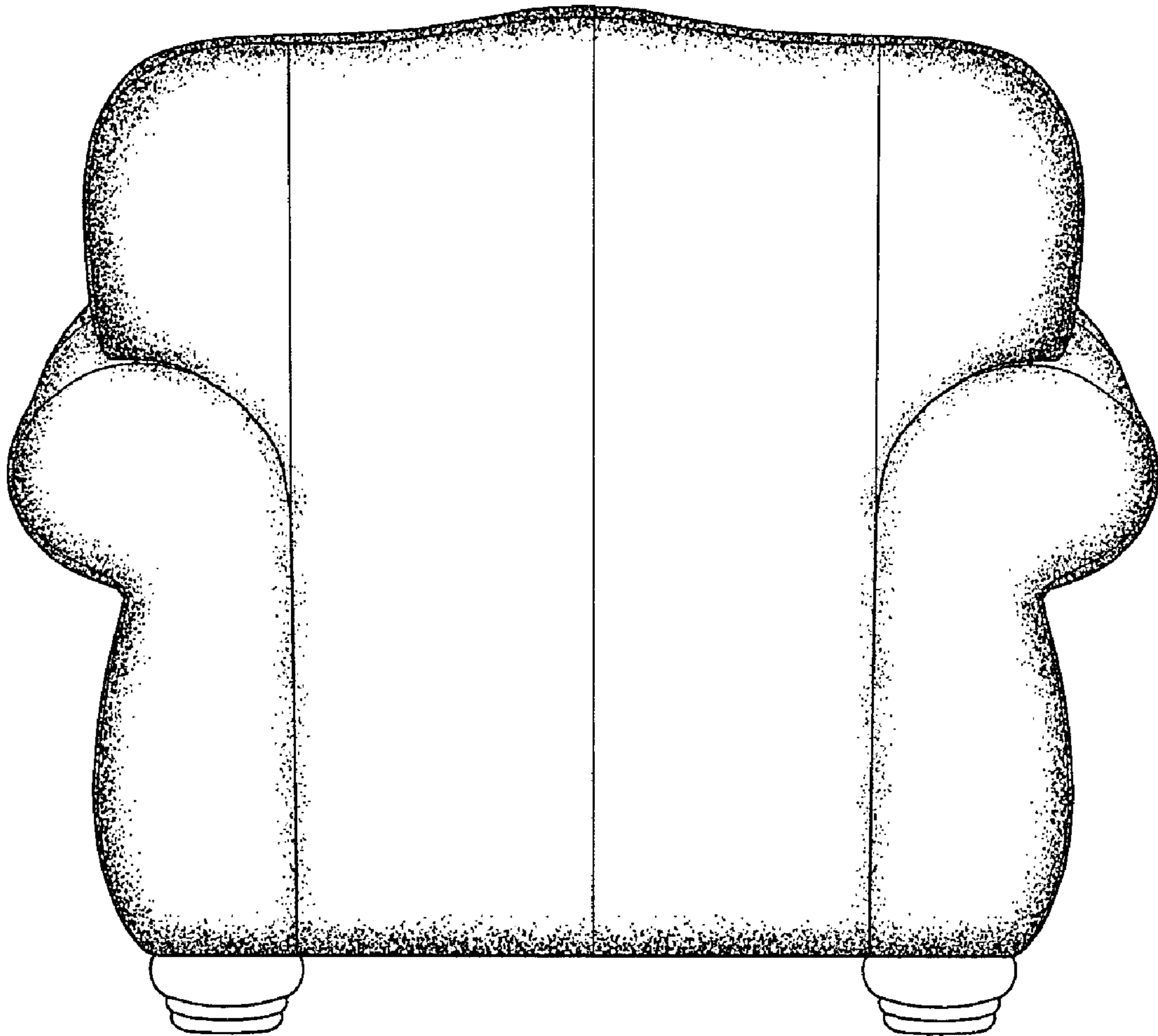

FIGURE 10



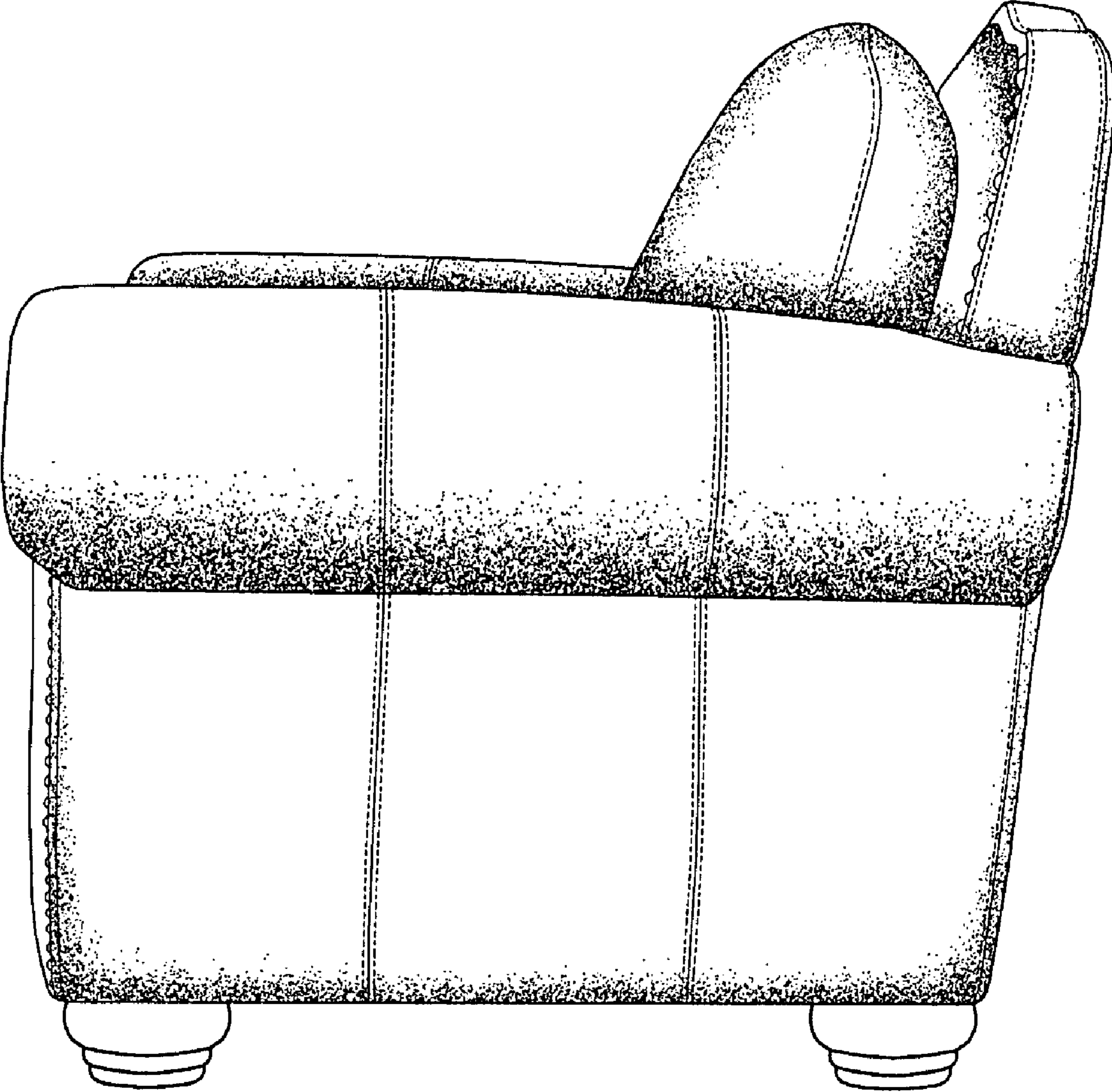

FIGURE 11

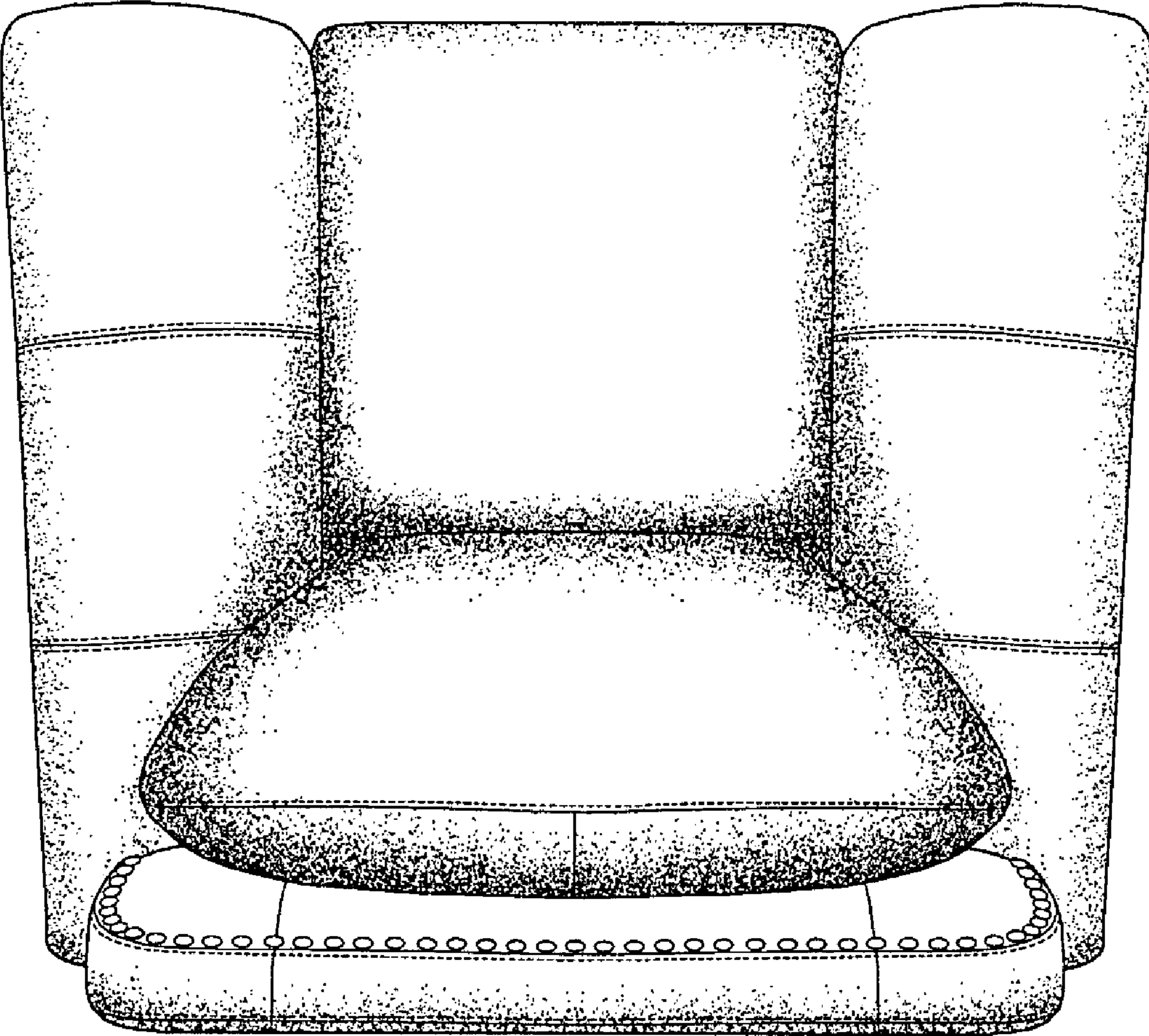

FIGURE 12