



US00D561351S

(12) **United States Design Patent**
Wyse

(10) **Patent No.:** **US D561,351 S**
(45) **Date of Patent:** **** Feb. 5, 2008**

(54) **SCAFFOLD FRAME SECTION WITH INTEGRAL GUARDRAIL POST**

(76) Inventor: **Steven J. Wyse**, 82 Pin Oak, Archbold, OH (US) 43502

(**) Term: **14 Years**

(21) Appl. No.: **29/237,566**

(22) Filed: **Sep. 1, 2005**

(51) **LOC (8) Cl.** **25-04**

(52) **U.S. Cl.** **D25/66**

(58) **Field of Classification Search** D25/66;
182/27, 115, 118, 130, 179.1, 113, 187; 52/651.1
See application file for complete search history.

(56) **References Cited**

U.S. PATENT DOCUMENTS

D403,783 S * 1/1999 Takai D25/66
6,223,857 B1 5/2001 Wyse

(Continued)

Primary Examiner—Doris Clark

(74) *Attorney, Agent, or Firm*—Hovey Williams LLP

(57) **CLAIM**

The ornamental design for a scaffold frame section with integral guardrail post, as shown and described.

DESCRIPTION

This application is being filed contemporaneously with application for U.S. patent Ser. No. 11/162,223, entitled Scaffold Frame Section With Intergral Guard Rail Post, which is hereby incorporated by reference herein.

FIG. 1 is a perspective view of a scaffold frame section with integral guardrail post embodying my design, with the frame locks, fasteners, insert pins, and accessory attachment holes being shown in broken lines for illustrative purposes only and forming no part of the claimed design;

FIG. 2 is a front elevation view of the scaffold frame section depicted in FIG. 1, with the rear elevation view being a mirror image thereof;

FIG. 3 is a side elevation view of the scaffold frame section depicted in FIGS. 1 and 2, with the opposite side elevation view being a mirror image thereof;

FIG. 4 is a top plan view of the scaffold frame section depicted in FIGS. 1–3;

FIG. 5 is a bottom plan elevation view of the scaffold frame section depicted in FIGS. 1–4;

FIG. 6 is a perspective view of the scaffold frame section depicted in FIGS. 1–5, particularly illustrating the frame section assembled with various other scaffolding components, but with such other scaffolding components being shown in broken lines for illustrative purposes only and forming no part of the claimed design;

FIG. 7 is a perspective view of a scaffold frame section with integral guardrail post embodying my design, with the angular braces, frame locks, fasteners, insert pins, and accessory attachment holes being shown in broken lines for illustrative purposes only and forming no part of the claimed design;

FIG. 8 is a front elevation view of the scaffold frame section depicted in FIG. 7, with the rear elevation view being a mirror image thereof;

FIG. 9 is a side elevation view of the scaffold frame section depicted in FIGS. 7 and 8, with the opposite side elevation view being a mirror image thereof;

FIG. 10 is a top plan view of the scaffold frame section depicted in FIGS. 7–9;

FIG. 11 is a bottom plan view of the scaffold frame section depicted in FIGS. 7–10; and,

FIG. 12 is a perspective view of the scaffold frame section depicted in FIGS. 7–11, particularly illustrating the frame section assembled with various other scaffolding components, but with such other scaffolding components being shown in broken lines for illustrative purposes only and forming no part of the claimed design.

1 Claim, 8 Drawing Sheets

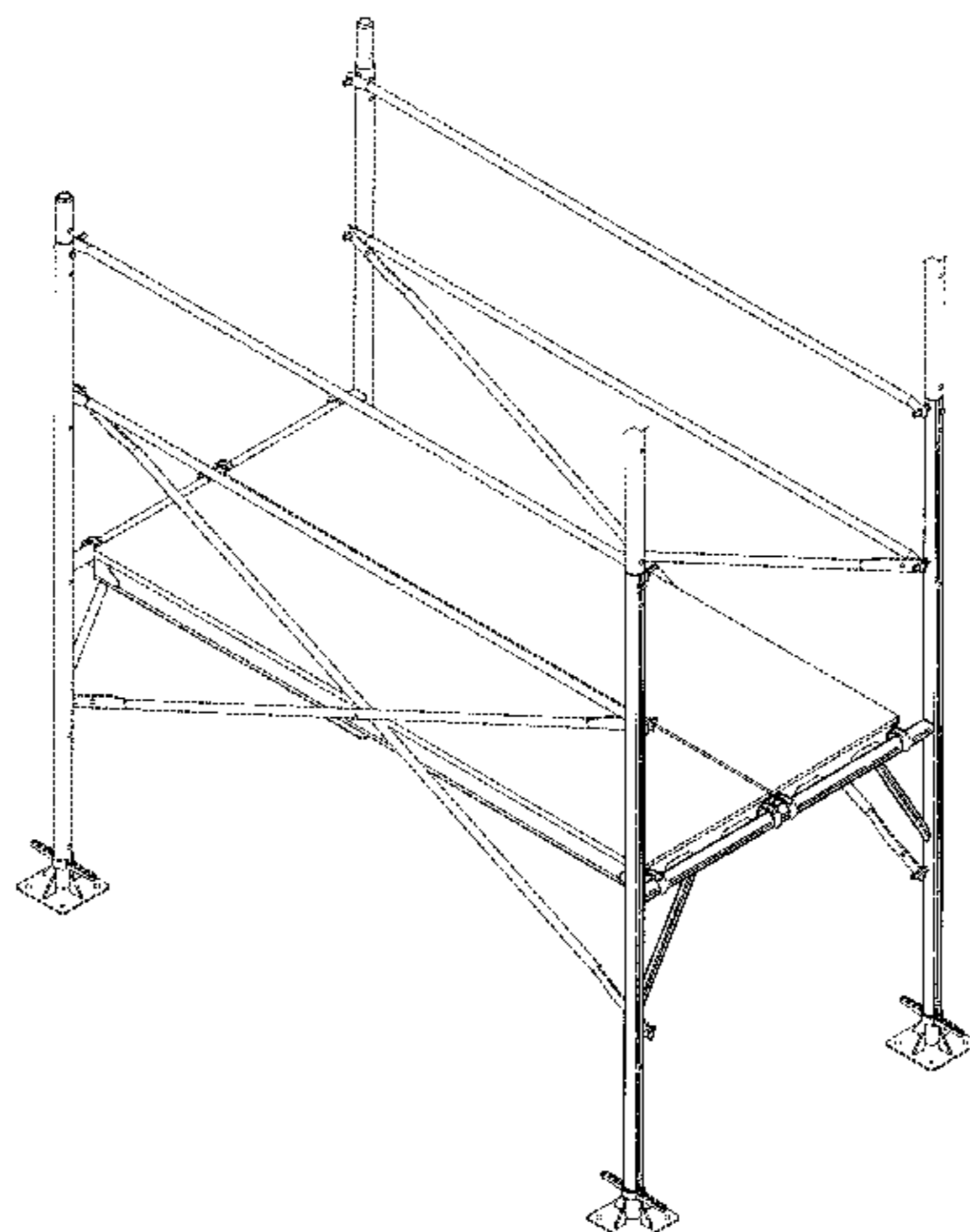

US D561,351 S

Page 2

U.S. PATENT DOCUMENTS

6,471,003 B2	10/2002	Wyse					
6,732,836 B2 *	5/2004	Ono	182/113			
6,761,247 B2	7/2004	Wyse					
					D495,426 S *	8/2004	Yamaoka D25/66
					6,863,155 B2	3/2005	Wyse et al.
					2004/0206576 A1 *	10/2004	So 182/179.1

* cited by examiner

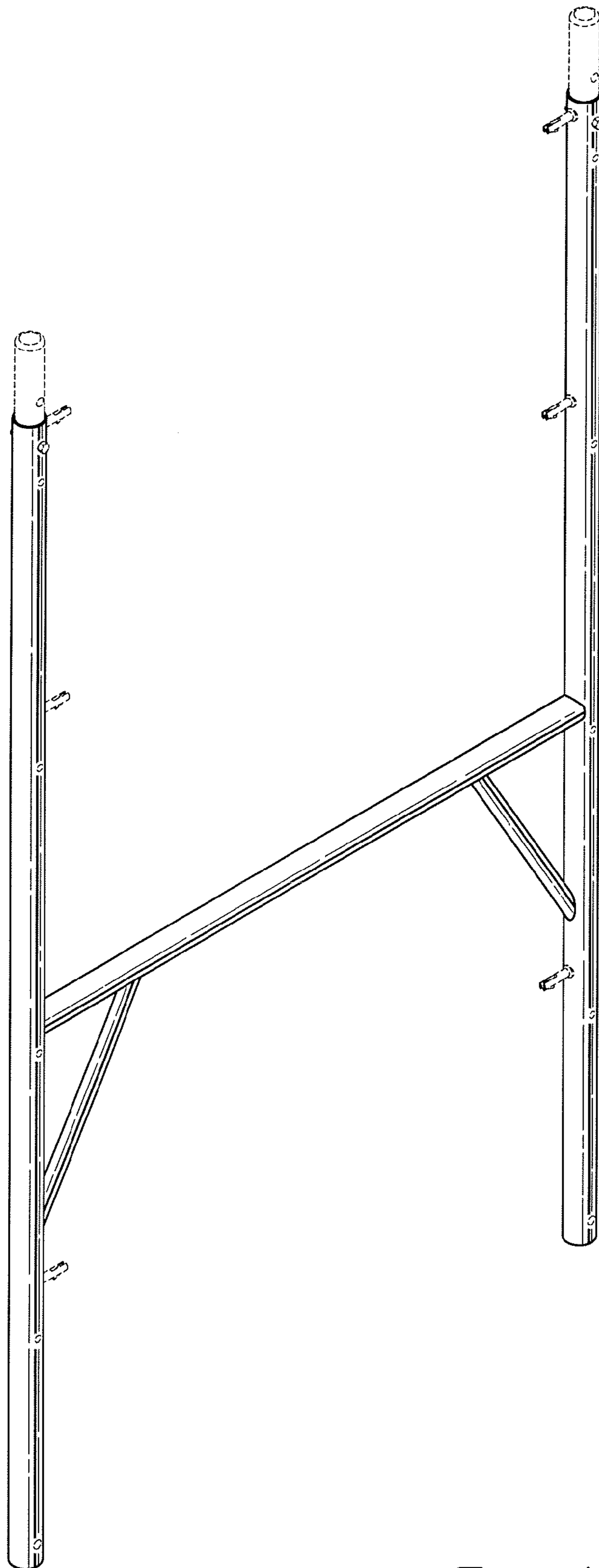

Fig. 1.

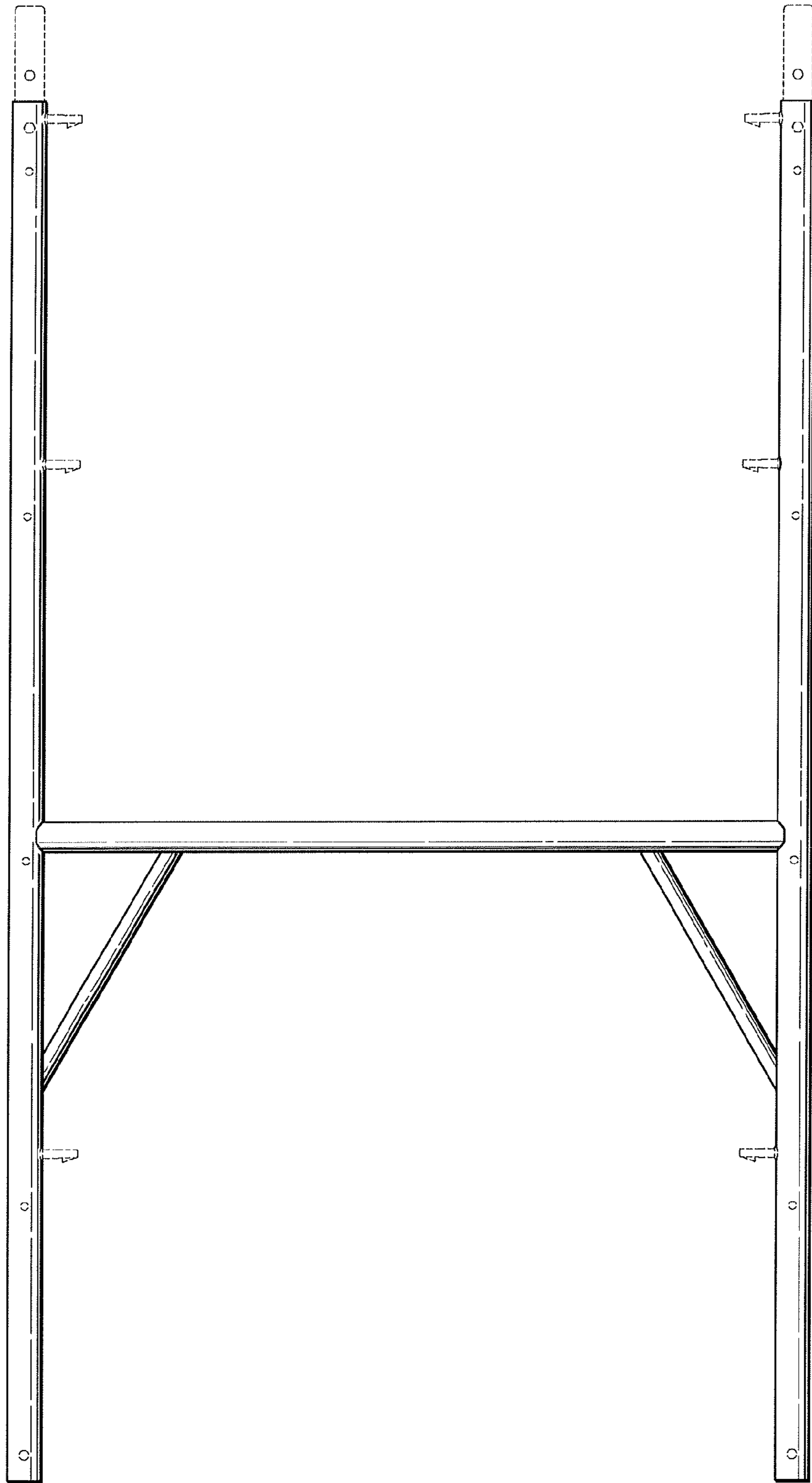

Fig. 2.



Fig. 3.

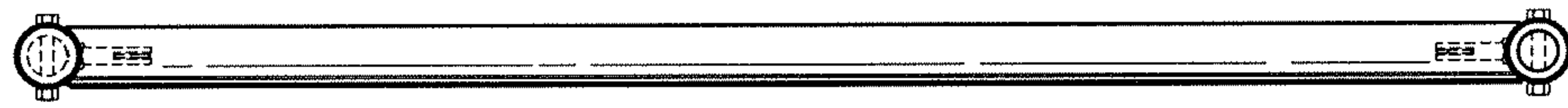

Fig. 4.

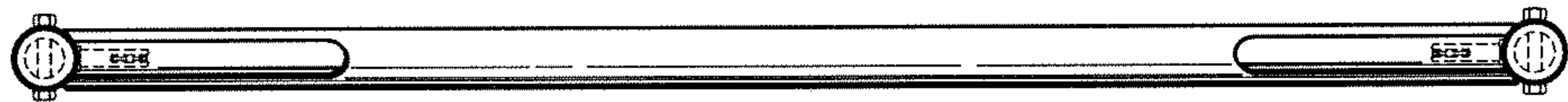

Fig. 5.

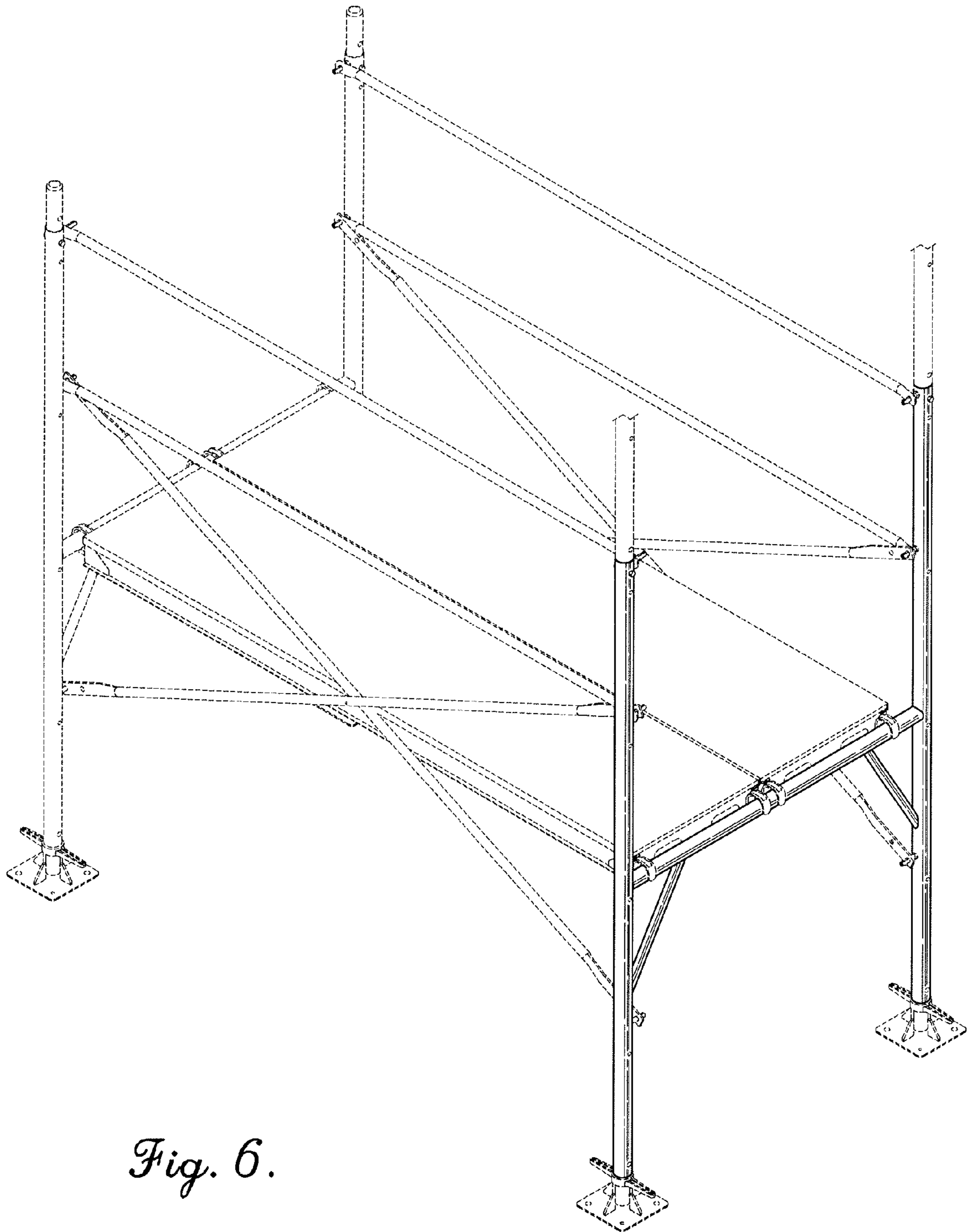

Fig. 6.

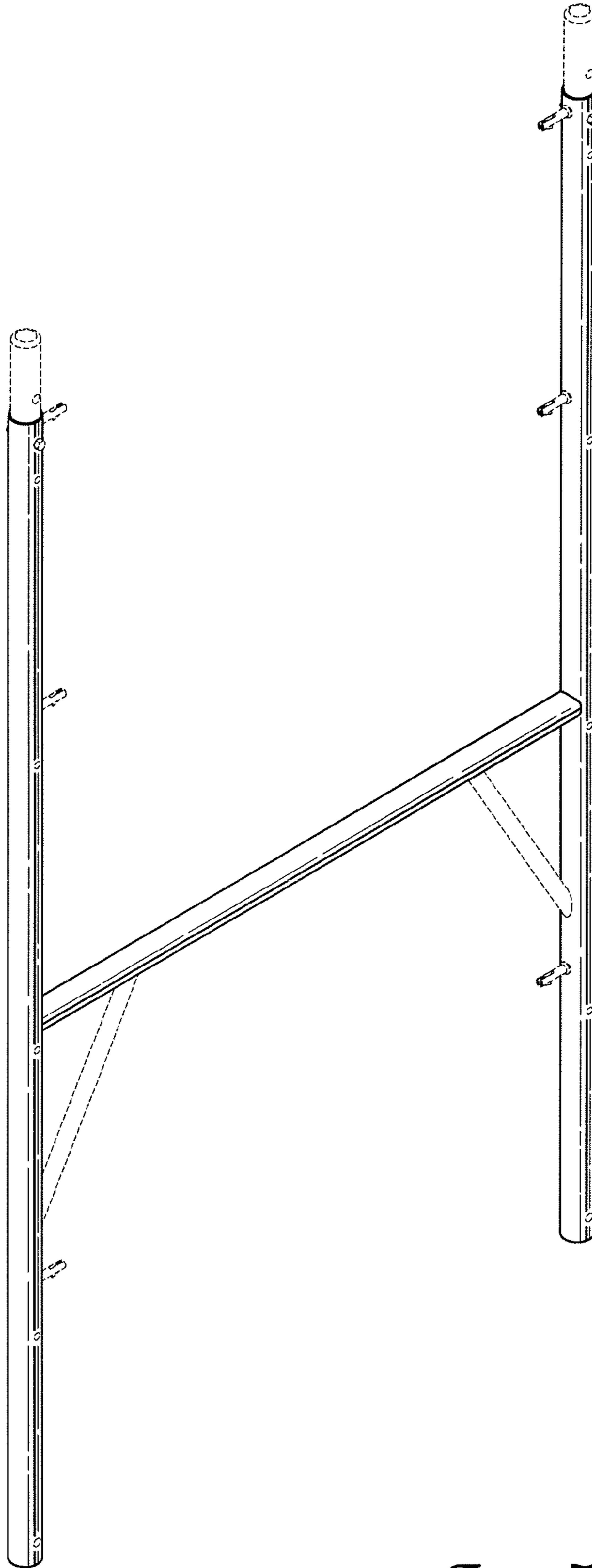

Fig. 7.

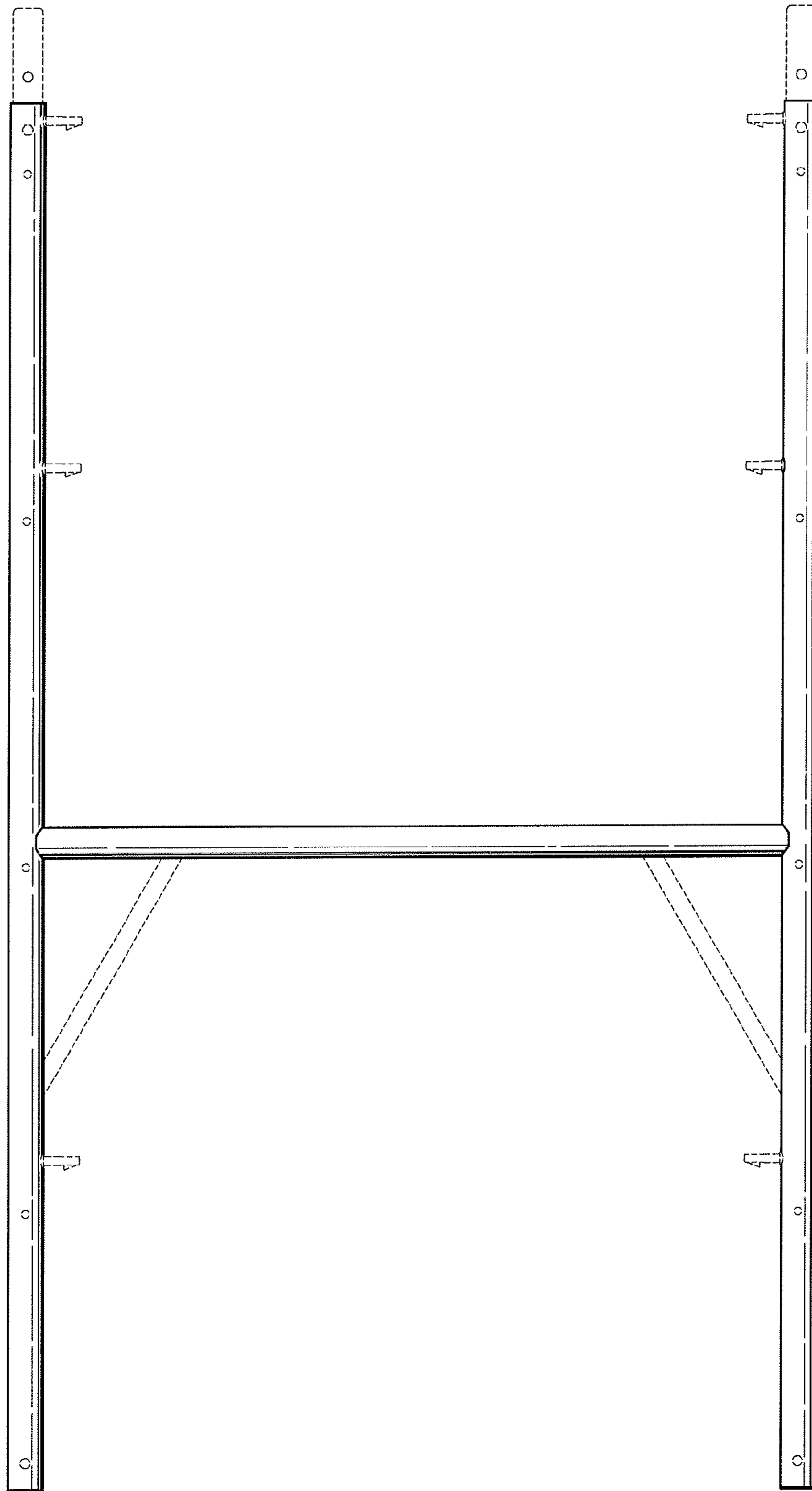

Fig. 8.



Fig. 9.

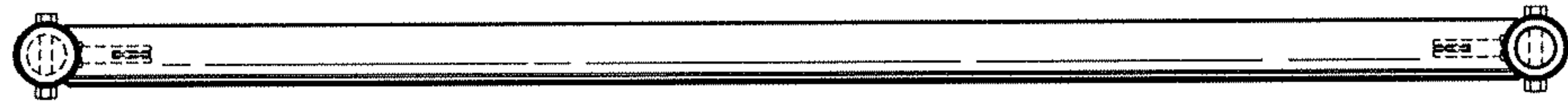

Fig. 10.

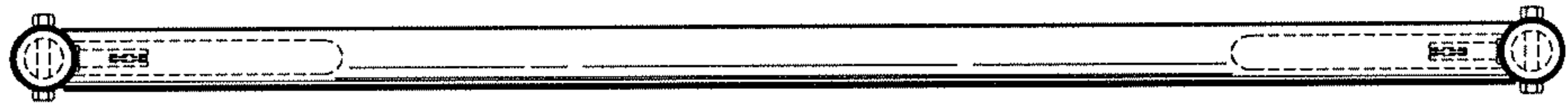

Fig. 11.

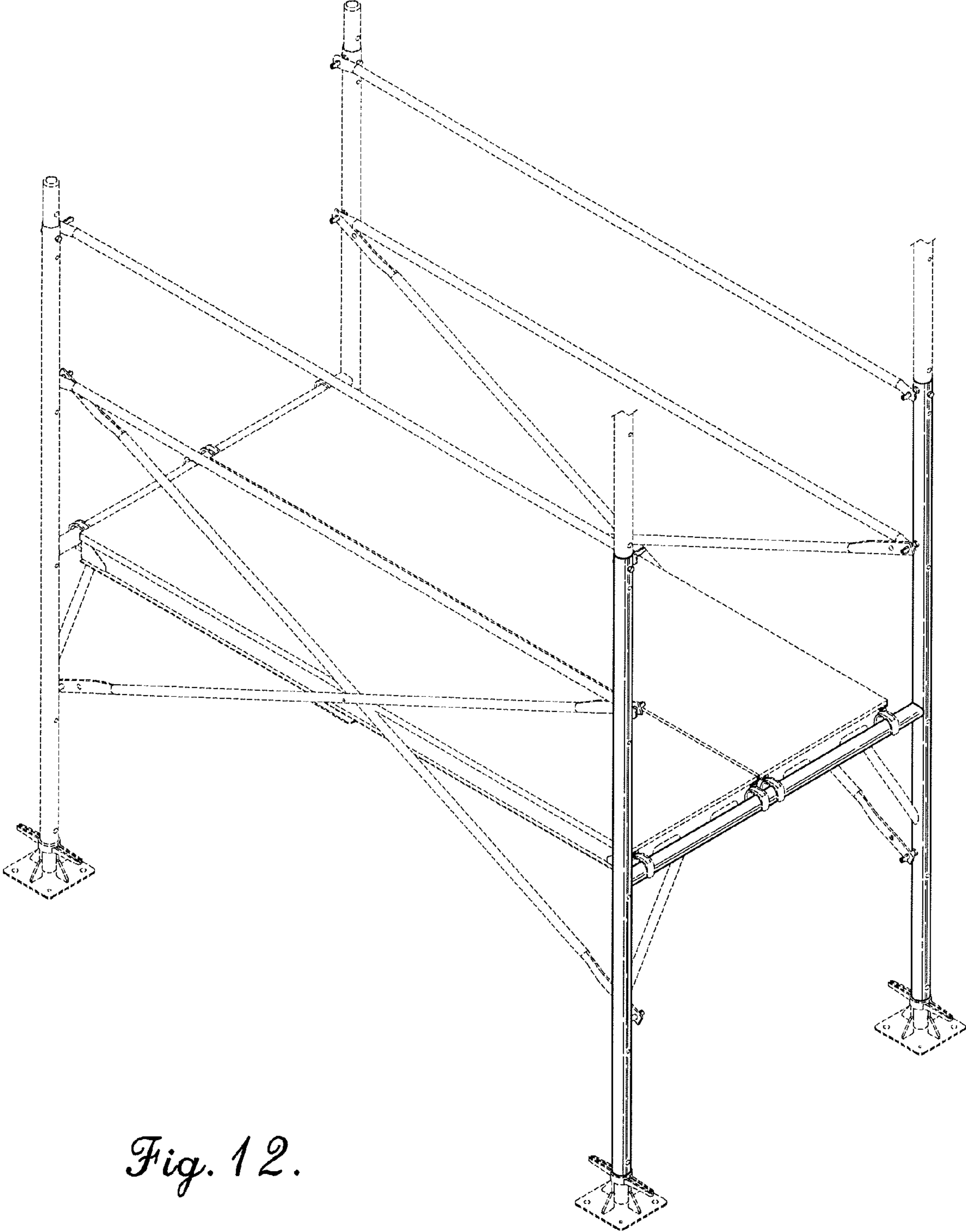

Fig. 12.