

US00D561079S

(12) **United States Design Patent** (10) **Patent No.:** **US D561,079 S**
Bigg (45) **Date of Patent:** **** Feb. 5, 2008**

(54) **VEHICLE HEADER**

(75) Inventor: **David K. Bigg**, Piqua, OH (US)

(73) Assignee: **Workhorse Custom Chassis, LLC**,
Union City, IN (US)

(**) Term: **14 Years**

(21) Appl. No.: **29/243,129**

(22) Filed: **Nov. 18, 2005**

(51) **LOC (8) Cl.** **12-16**

(52) **U.S. Cl.** **D12/194**

(58) **Field of Classification Search** D12/110,
D12/194, 400; 181/227, 228, 239, 247-249,
181/264, 277-280, 282; D15/5; 60/313,
60/323; 29/890.08, 113; 138/37-39, 44,
138/103, 109; 180/89.2, 309, 296

See application file for complete search history.

(56) **References Cited**

U.S. PATENT DOCUMENTS

3,507,301	A *	4/1970	Larson	29/890.08
4,022,019	A *	5/1977	Garcea	29/890.08
D289,766	S *	5/1987	Evans	D12/194
4,959,956	A *	10/1990	Yasuda	29/890.08
5,199,258	A *	4/1993	Barth	60/313
5,365,437	A	11/1994	Cunningham et al.		
D368,247	S *	3/1996	Jones	D12/194
5,572,868	A *	11/1996	Okamoto et al.	29/890.08
5,678,404	A	10/1997	McManus		
5,765,373	A *	6/1998	Bittle et al.	60/313
5,816,044	A *	10/1998	Biggs	60/313
5,816,045	A *	10/1998	Blocker et al.	60/323
D406,593	S *	3/1999	Bittle	D15/5
5,887,428	A *	3/1999	Garisto	29/890.08
5,940,968	A *	8/1999	Bittle et al.	29/890.08
6,038,769	A *	3/2000	Bonny et al.	29/890.08

6,152,853	A	11/2000	Banks, III		
6,343,417	B1 *	2/2002	Bonny et al.	29/890.08
6,467,260	B2 *	10/2002	Bittle et al.	60/313
6,581,377	B2 *	6/2003	Carlson et al.	60/323
6,634,171	B1	10/2003	Banks, III		
D481,662	S *	11/2003	James	D12/194
6,652,414	B1	11/2003	Banks, III		
D484,513	S *	12/2003	Grudynski, III	D15/5
D533,568	S *	12/2006	Thomas	D15/5
2001/0039799	A1 *	11/2001	Bittle et al.	60/323
2003/0106311	A1 *	6/2003	Moore et al.	60/323
2004/0020195	A1 *	2/2004	Ashida et al.	60/302
2005/0115765	A1 *	6/2005	Minato	181/240
2006/0005535	A1 *	1/2006	Ashida et al.	60/302
2006/0085982	A1 *	4/2006	Sturtevant et al.	29/890.08

* cited by examiner

Primary Examiner—Cathron Brooks

Assistant Examiner—Michael A. Pratt

(74) *Attorney, Agent, or Firm*—Banner & Witcoff, Ltd.

(57) **CLAIM**

I claim the ornamental design for a vehicle header, as shown and described.

DESCRIPTION

FIG. 1 is a perspective view of a vehicle header;

FIG. 2 is a top view of the header of FIG. 1;

FIG. 3 is a left side view of the header of FIG. 1;

FIG. 4 is a right side view of the header of FIG. 1;

FIG. 5 is a bottom view of the header of FIG. 1;

FIG. 6 is a rear view of the header of FIG. 1; and,

FIG. 7 is a front view of the header of FIG. 1.

The broken lines in FIGS. 1 through 7 are for illustrative purposes only and form no part of the claimed design.

1 Claim, 2 Drawing Sheets

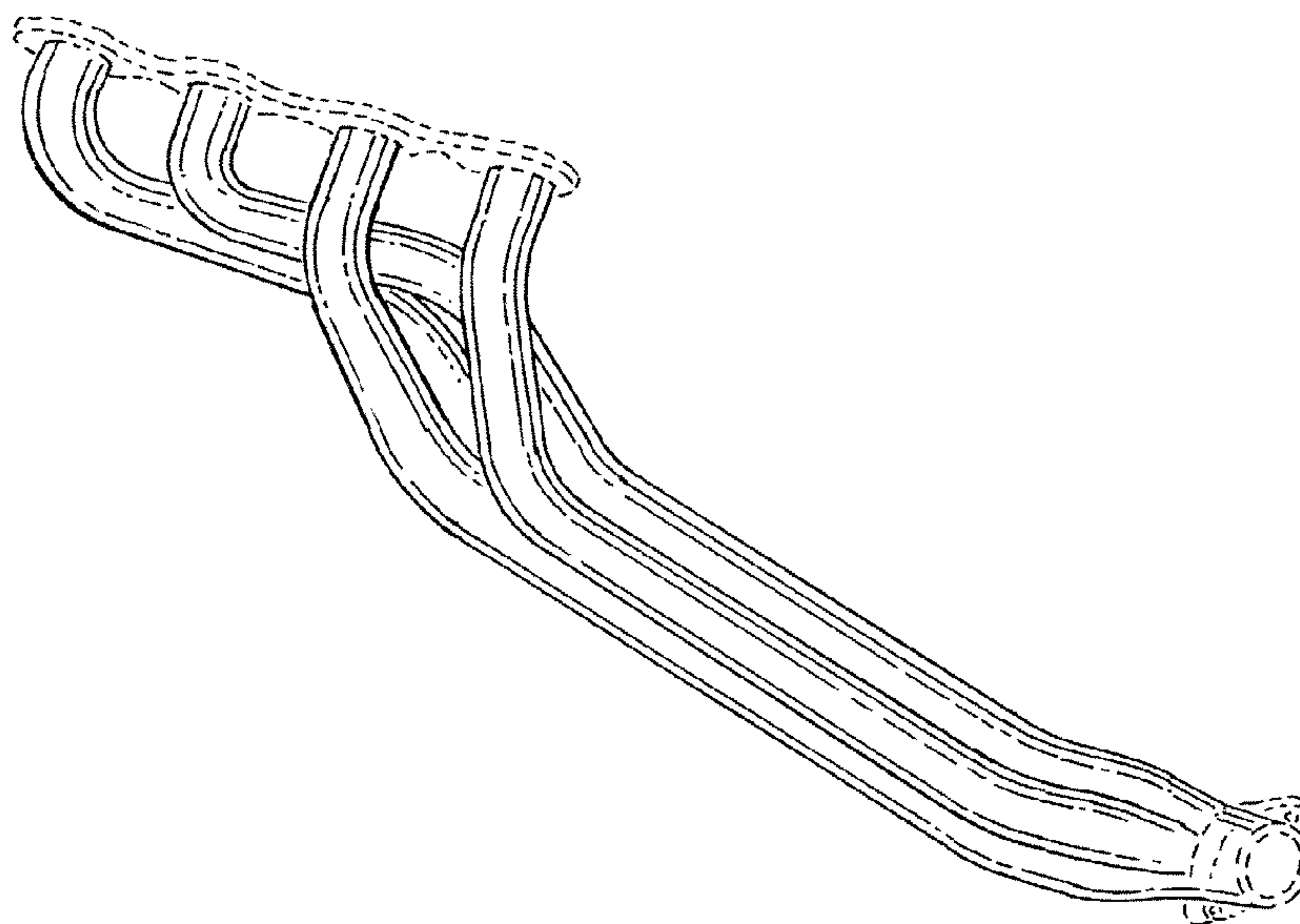

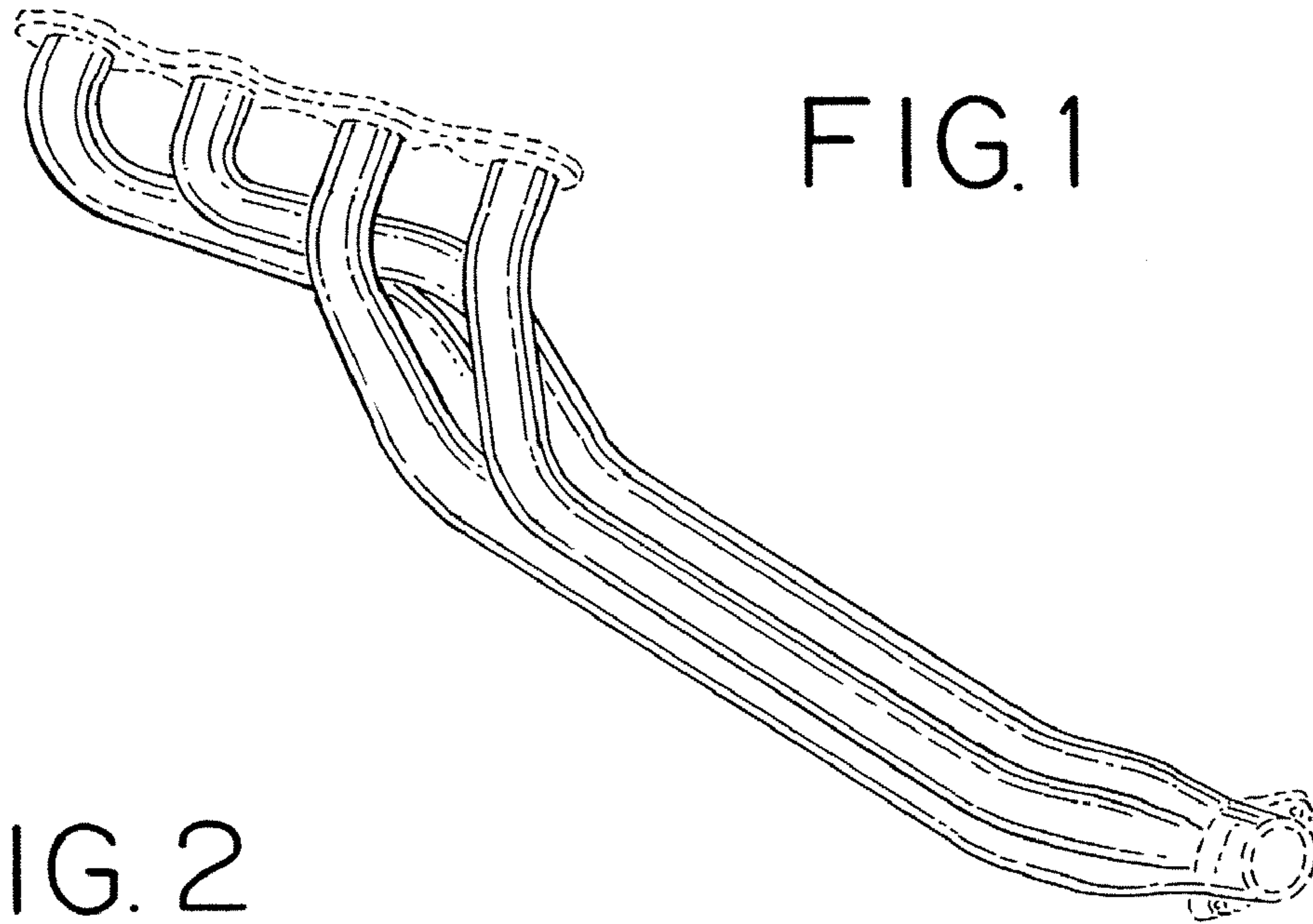

FIG. 2

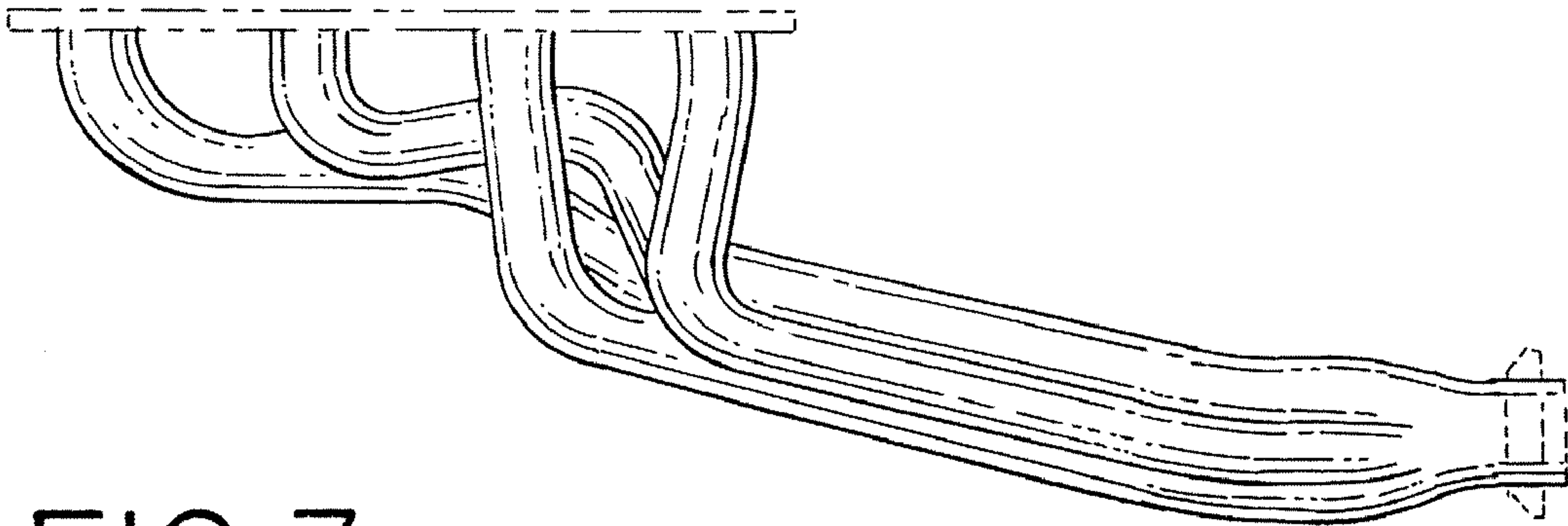

FIG. 3

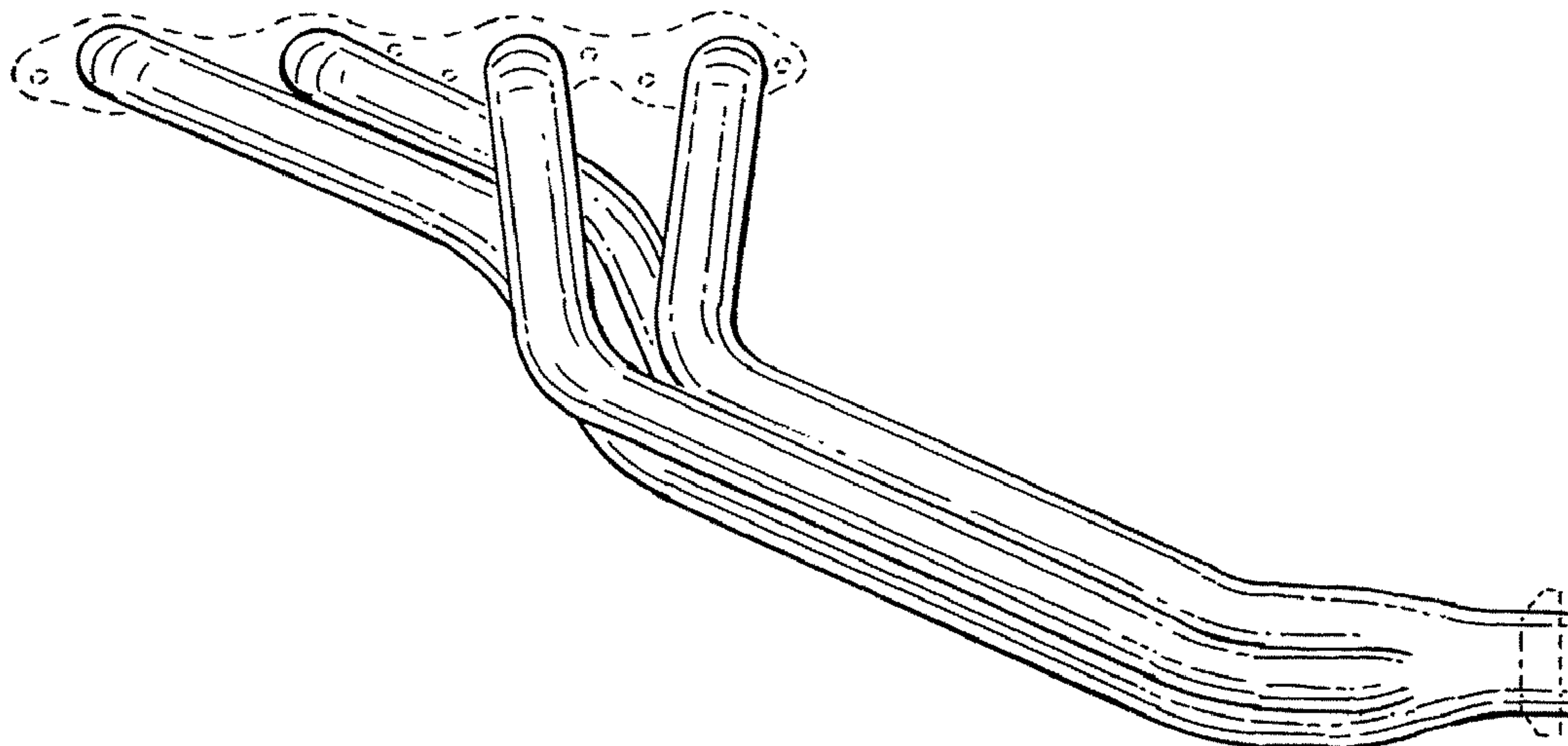

FIG. 4

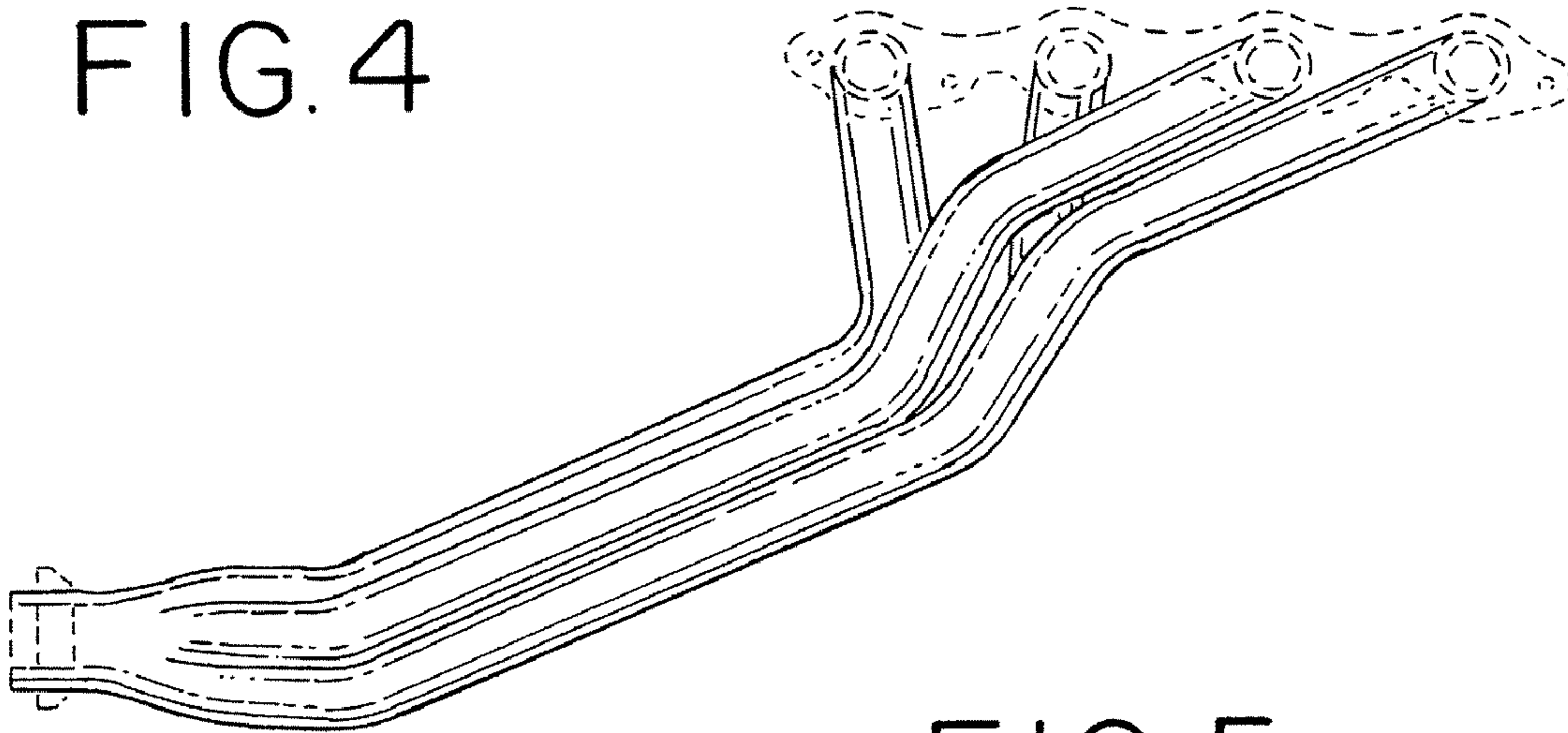

FIG. 5

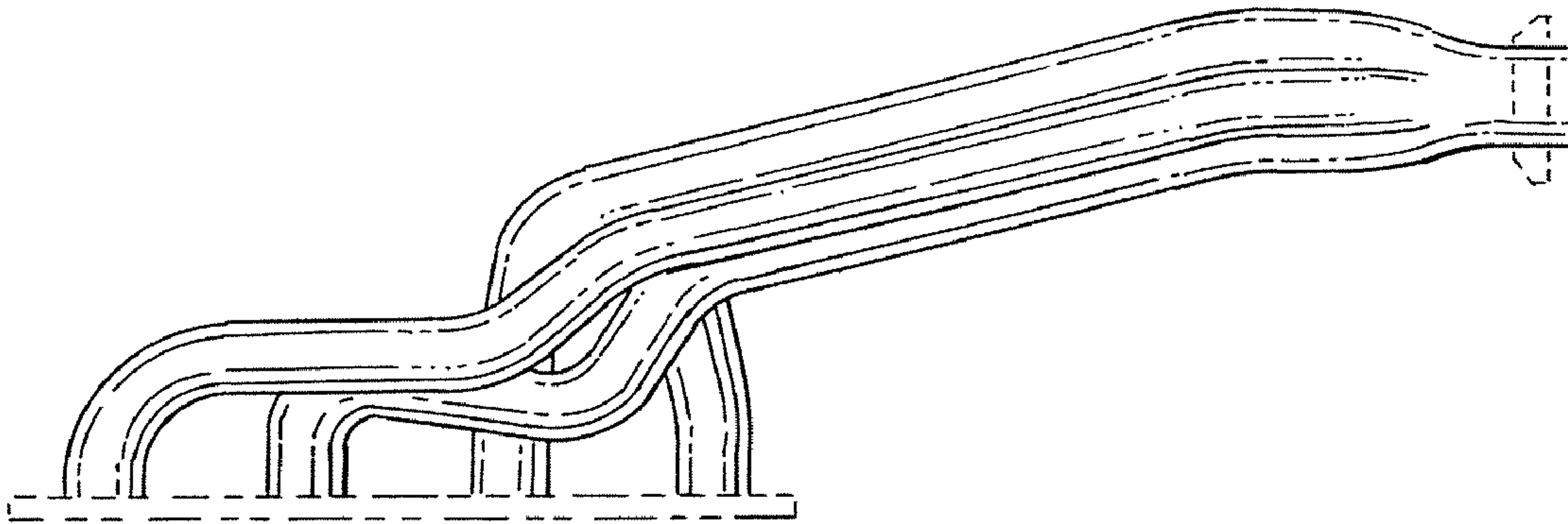

FIG. 6

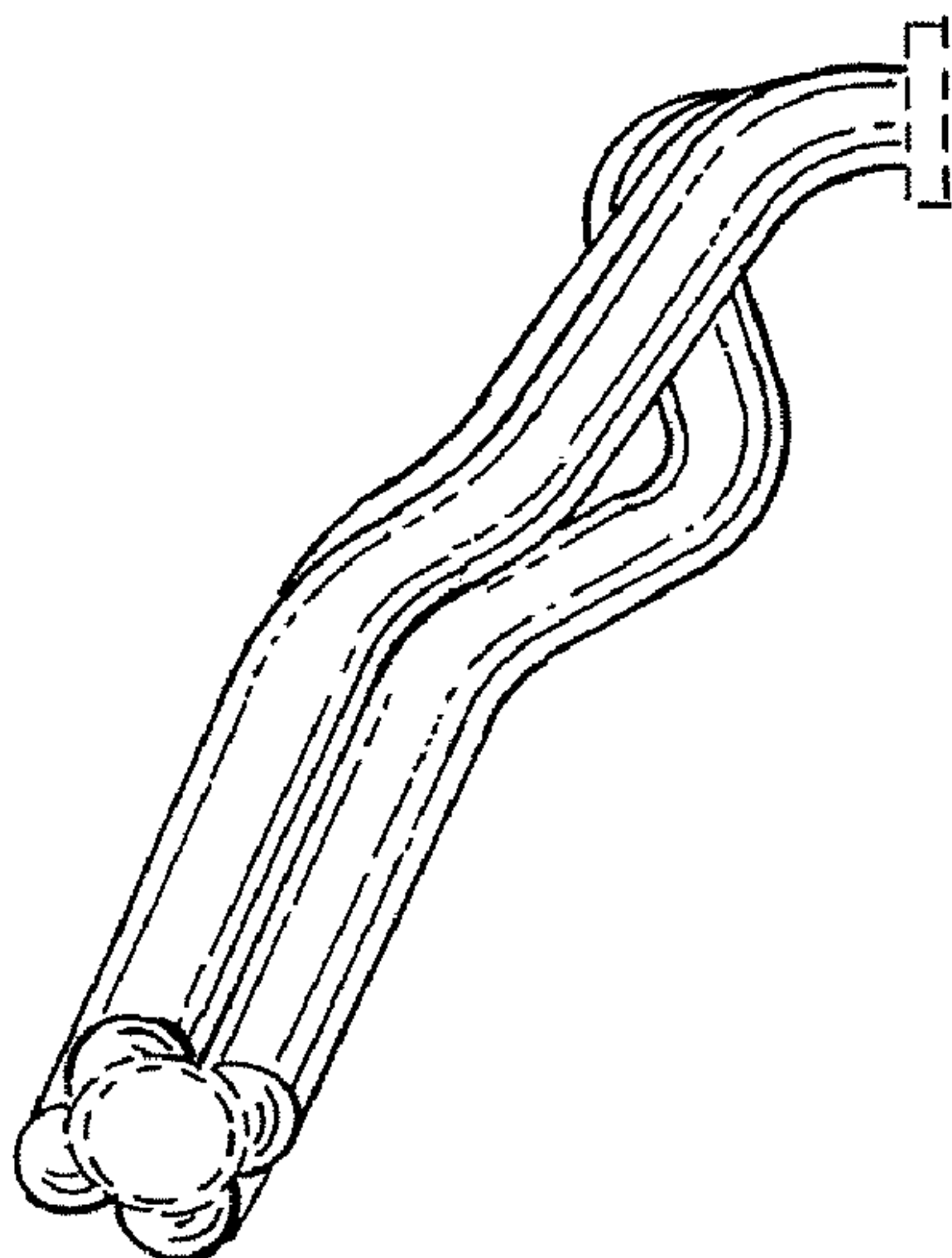

FIG. 7

