



US00D560930S

(12) **United States Design Patent** (10) **Patent No.:** **US D560,930 S**  
**Woodward et al.** (45) **Date of Patent:** **\*\* Feb. 5, 2008**

(54) **AUDIO VIDEO FURNITURE**

*Primary Examiner*—Cathron C. Brooks  
*Assistant Examiner*—Kelley A. Donnelly

(75) Inventors: **Mark P Woodward**, Lakewood, CO (US); **Michael J Abdella**, Lakewood, CO (US); **Landon S Robinson**, Arvada, CO (US)

(74) *Attorney, Agent, or Firm*—Leyendecker & Lemire, LLC; Kurt Leyendecker

(73) Assignee: **Subliminal Entertainment, Inc.**, Lakewood, CO (US)

(57) **CLAIM**

An ornamental design for a piece of audio video furniture, as shown and described.

(\*\*) Term: **14 Years**

(21) Appl. No.: **29/275,743**

(22) Filed: **Jan. 5, 2007**

(51) **LOC (8) Cl.** ..... **06-04**

(52) **U.S. Cl.** ..... **D6/446**; D6/436; D6/478; D6/495; D6/509

(58) **Field of Classification Search** ..... D6/436, D6/444, 477–479, 470, 446, 432, 441, 445–448; 312/114, 204, 224, 278–279  
See application file for complete search history.

**DESCRIPTION**

FIG. 1 is an isometric front view of the piece of furniture according to the present invention.

FIG. 2 is another isometric front view of the piece of furniture according to the embodiment of the present invention showing a particular grill design in broken line to provide further context to the embodiment.

FIG. 3 is an isometric view of the pillar member utilized in various locations in the piece of furniture and shown separately for completeness of illustration; and,

FIG. 4 is a top view of the pillar member shown separately for completeness of illustration.

The broken lines shown in the drawings illustrate portions of the furniture that form no part of the claimed design.

(56) **References Cited**

**U.S. PATENT DOCUMENTS**

D336,392 S *	6/1993	Whalen	.....	D6/446
D477,474 S *	7/2003	Milligan	.....	D6/446
D522,773 S *	6/2006	Becker	.....	D6/470

\* cited by examiner

**1 Claim, 3 Drawing Sheets**

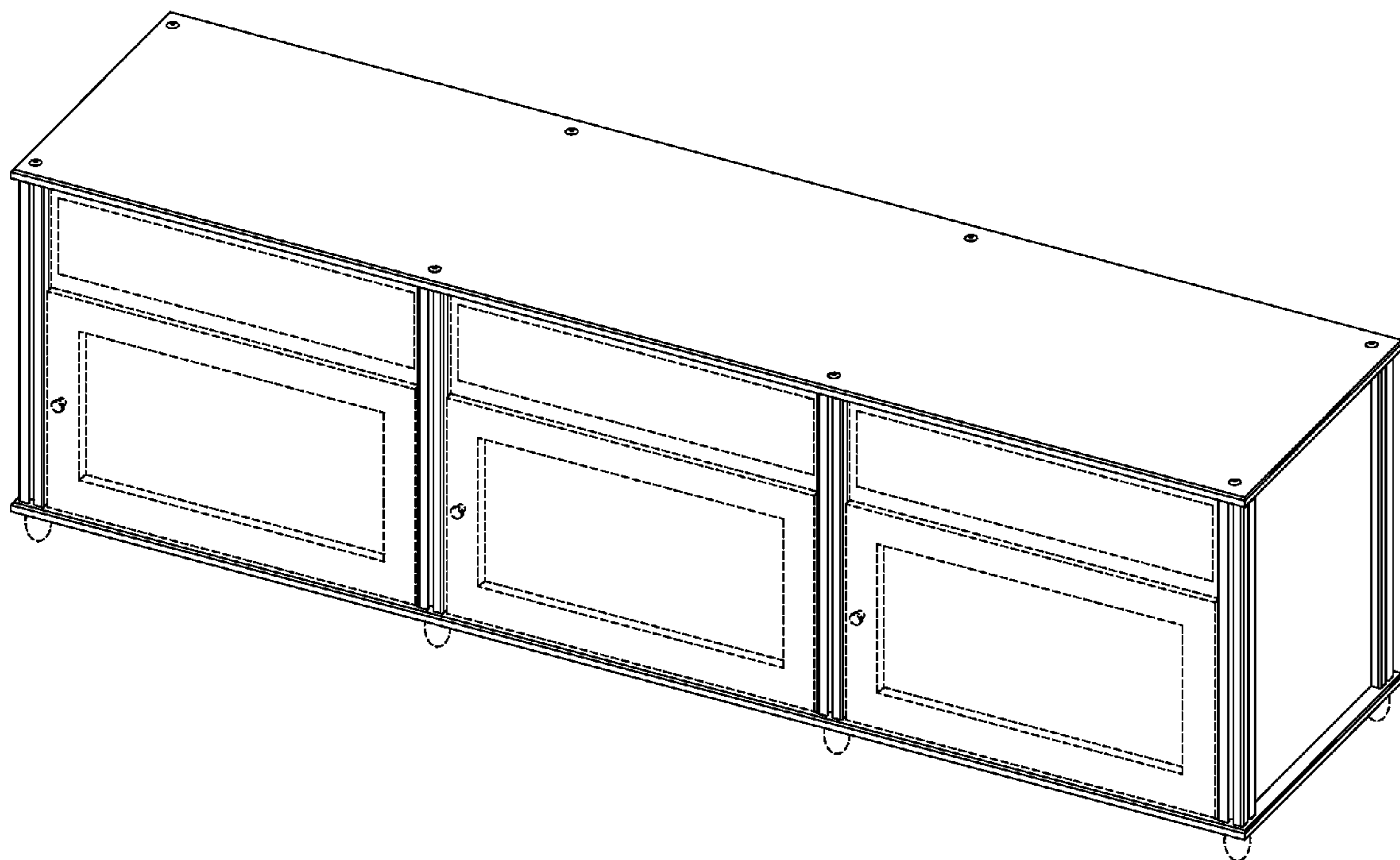

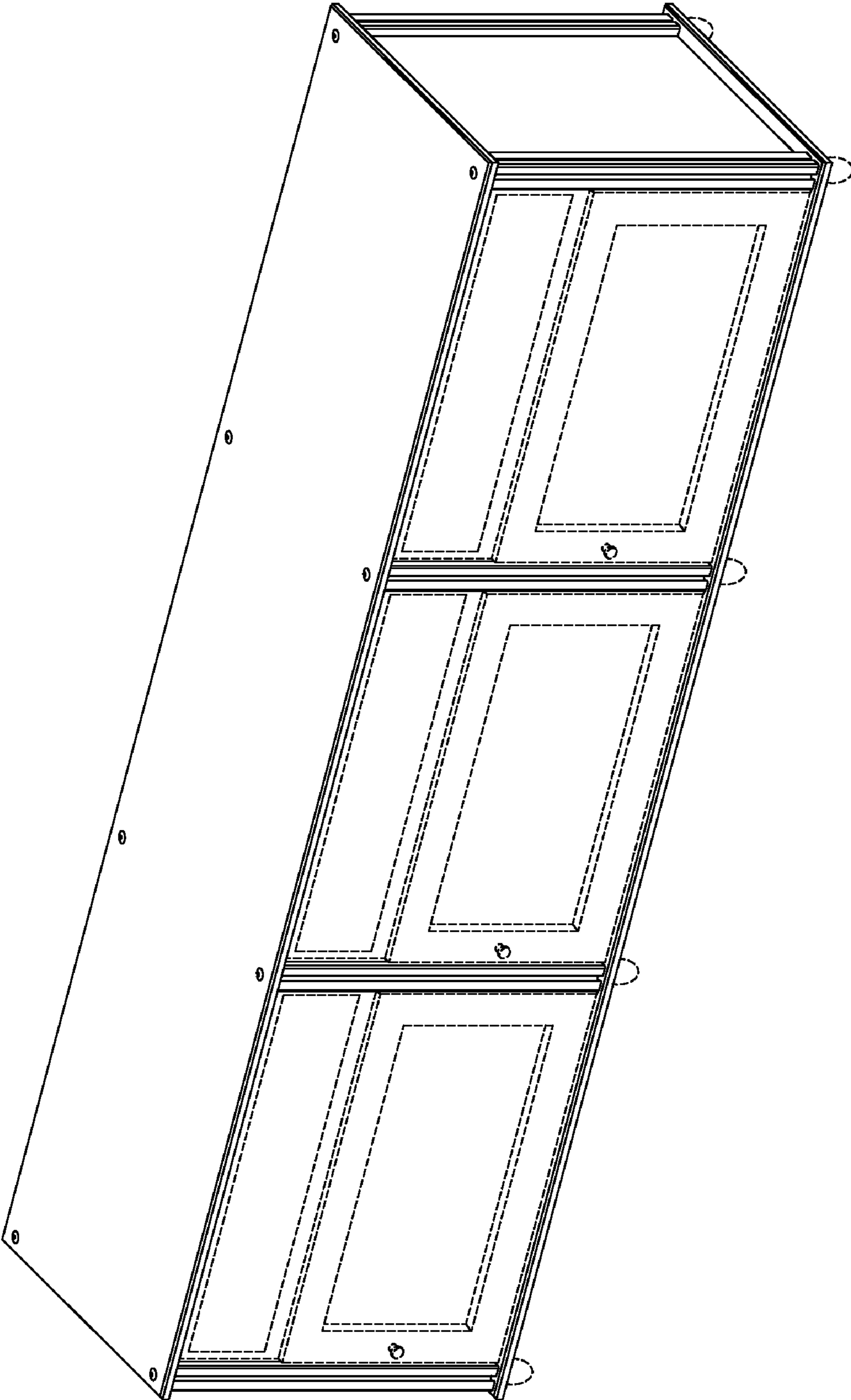

Fig. 1

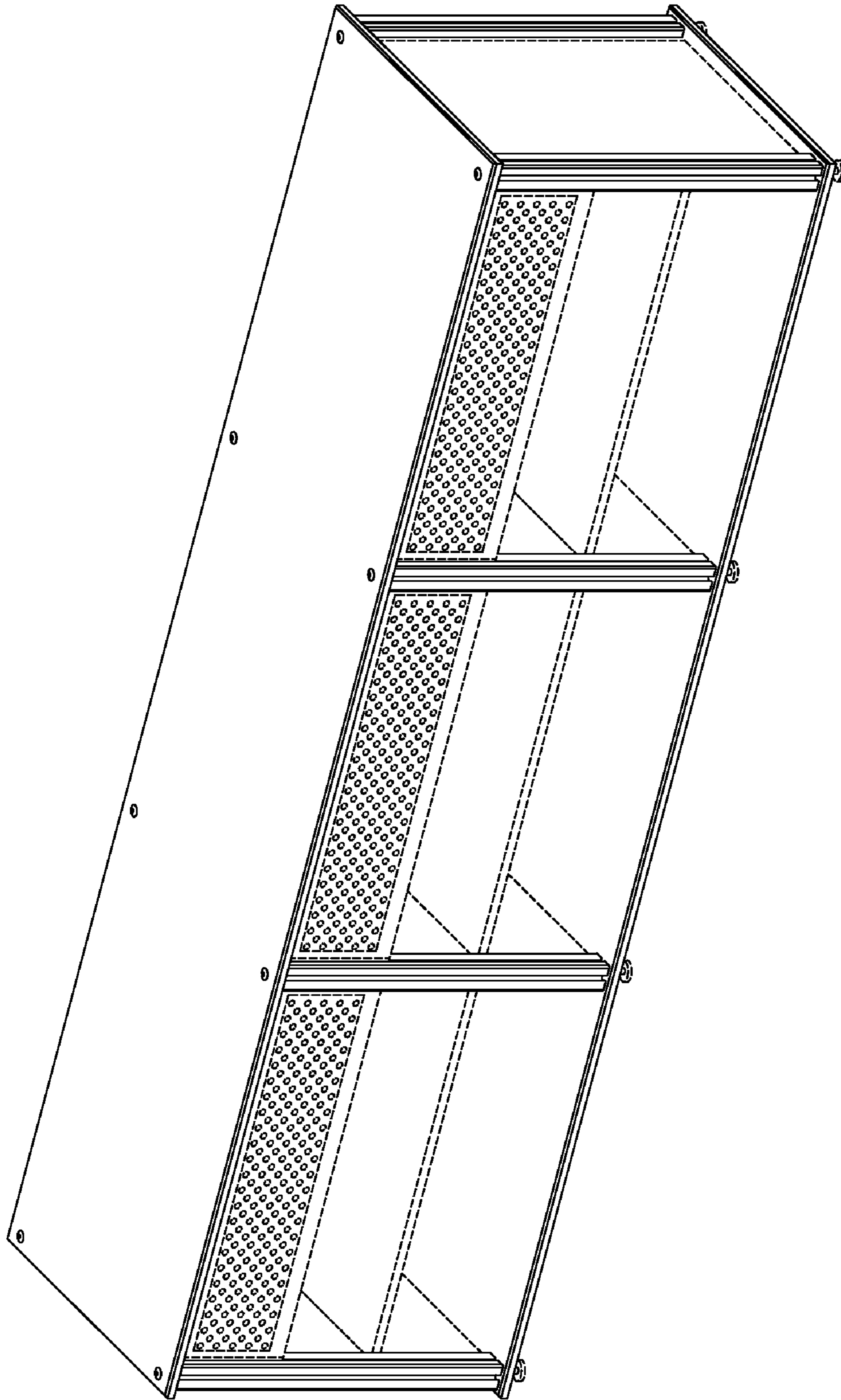

Fig. 2

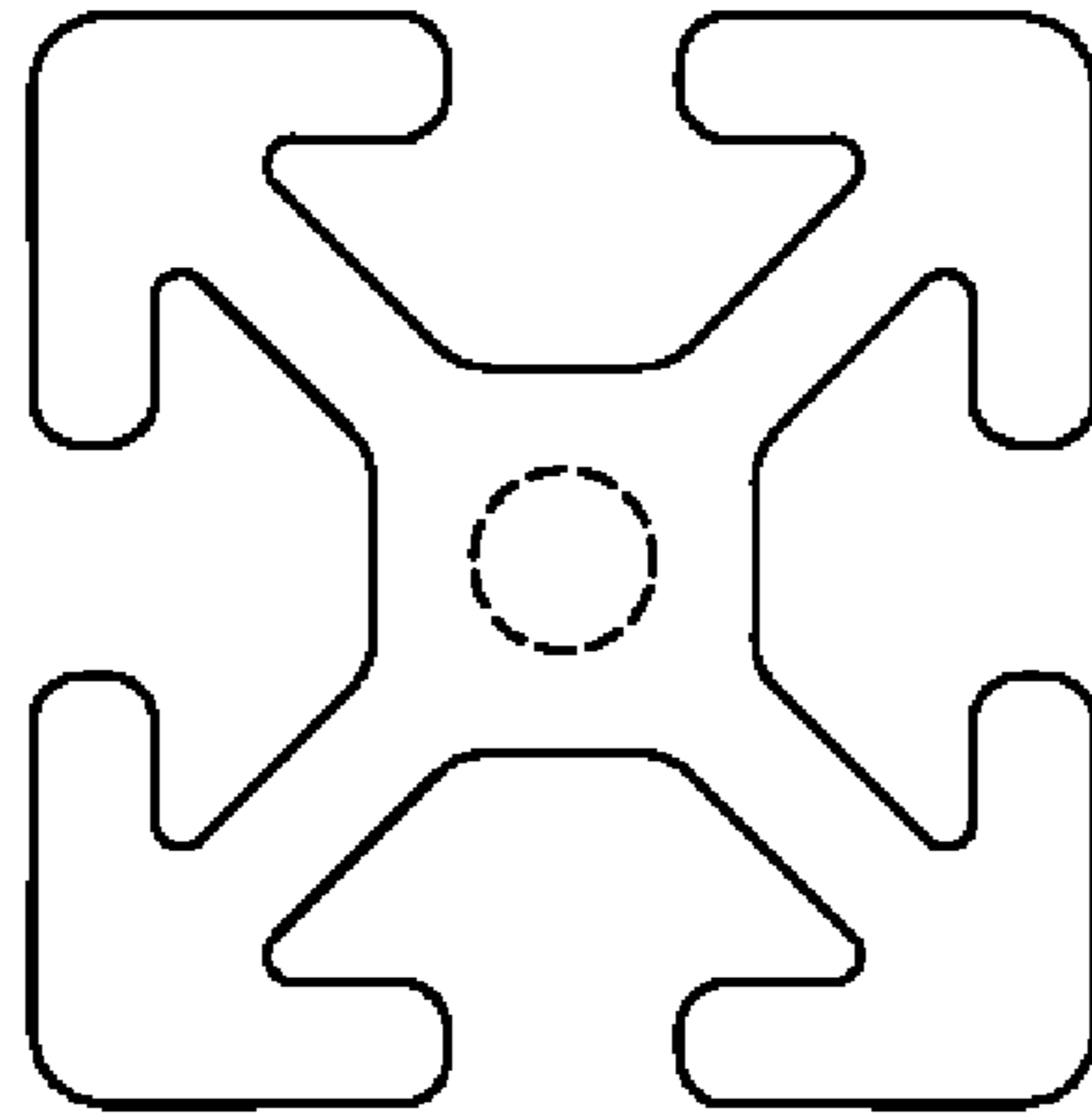

Fig. 4

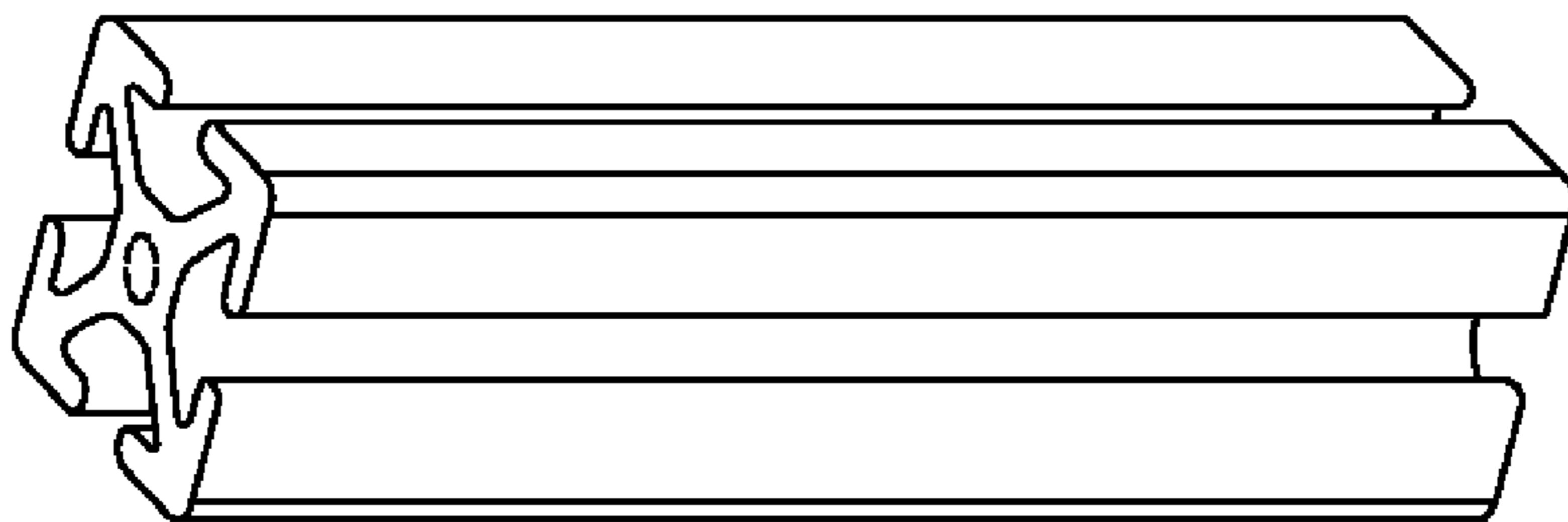

Fig. 3