

US00D560844S

(12) **United States Design Patent**
Levy et al.

(10) **Patent No.:** **US D560,844 S**
(45) **Date of Patent:** **** Jan. 29, 2008**

(54) **LAMP**

(75) Inventors: **Edward Levy**, Centennial, CO (US);
Campbell Levy, Centennial, CO (US)

(73) Assignee: **Campbell Levy Designs LLC**,
Centennial, CO (US)

(**) Term: **14 Years**

(21) Appl. No.: **29/248,281**

(22) Filed: **Aug. 7, 2006**

(51) **LOC (8) Cl.** **26-03**

(52) **U.S. Cl.** **D26/97**

(58) **Field of Classification Search** D26/51,
D26/57, 93-112, 142; D15/1, 5, 148; 123/197.3,
123/197.4; 384/429-432, 250, 457; 362/410-414,
362/253-806

See application file for complete search history.

(56) **References Cited**

U.S. PATENT DOCUMENTS

2,109,083 A	2/1938	Campbell	
3,113,732 A	12/1963	Chilo	
D317,770 S	6/1991	Burke	
D468,854 S	1/2003	Chen	
D500,572 S	1/2005	Linder	
D508,142 S	8/2005	Lizarraga	
7,021,268 B1	4/2006	Fuoss	
2007/0153534 A1*	7/2007	Levy et al.	362/414

OTHER PUBLICATIONS

Crankshaft Lamp, eBay product No. 6166294093, retrieved on Oct. 17, 2006 by the Examiner of U.S. Appl. No. 29/247,350, 7 pages.
Motor Trend Sep. 2004, Heavy Metal Crank Lamp, p. 145 TLI. M925, 2 pages.
www.campbelllevydesign.com, believed to be in existence since Dec. 2005, 4 pages.
Non-final Office Action of related 29/247,350, Dec. 5, 2006, 18 pages.
Non-final Office Action of related 29/247,350, May 21, 2007, 7 pages.

* cited by examiner

Primary Examiner—Cathron Brooks

Assistant Examiner—Linda Brooks

(74) *Attorney, Agent, or Firm*—Sheridan Ross P.C.

(57) **CLAIM**

The ornamental design for a lamp, as shown and described.

DESCRIPTION

FIG. 1 is a perspective view of a lamp showing our new design, the broken lines showing environment for illustrative purposes only and forming no part of the claimed design;

FIG. 2 is a bottom plan view of the design illustrated in FIG. 1;

FIG. 3 is a top plan view of the design illustrated in FIG. 1;

FIG. 4 is a front elevation view of the design illustrated in FIG. 1;

FIG. 5 is a right elevation view of the design illustrated in FIG. 1;

FIG. 6 is a rear elevation view of the design illustrated in FIG. 1;

FIG. 7 is a left elevation view of the design illustrated in FIG. 1;

FIG. 8 is a perspective view of a first alternative embodiment of the design illustrated in FIG. 1, the only distinction being the addition of a shade, it being understood that all other surfaces are the same as those in the first embodiment, the broken lines showing environment for illustrative purposes only and forming no part of the claimed design;

FIG. 9 is a bottom plan view of the design illustrated in FIG. 8;

FIG. 10 is a top plan view of the design illustrated in FIG. 8;

FIG. 11 is a front elevation view of the design illustrated in FIG. 8;

FIG. 12 is a right elevation view of the design illustrated in FIG. 8;

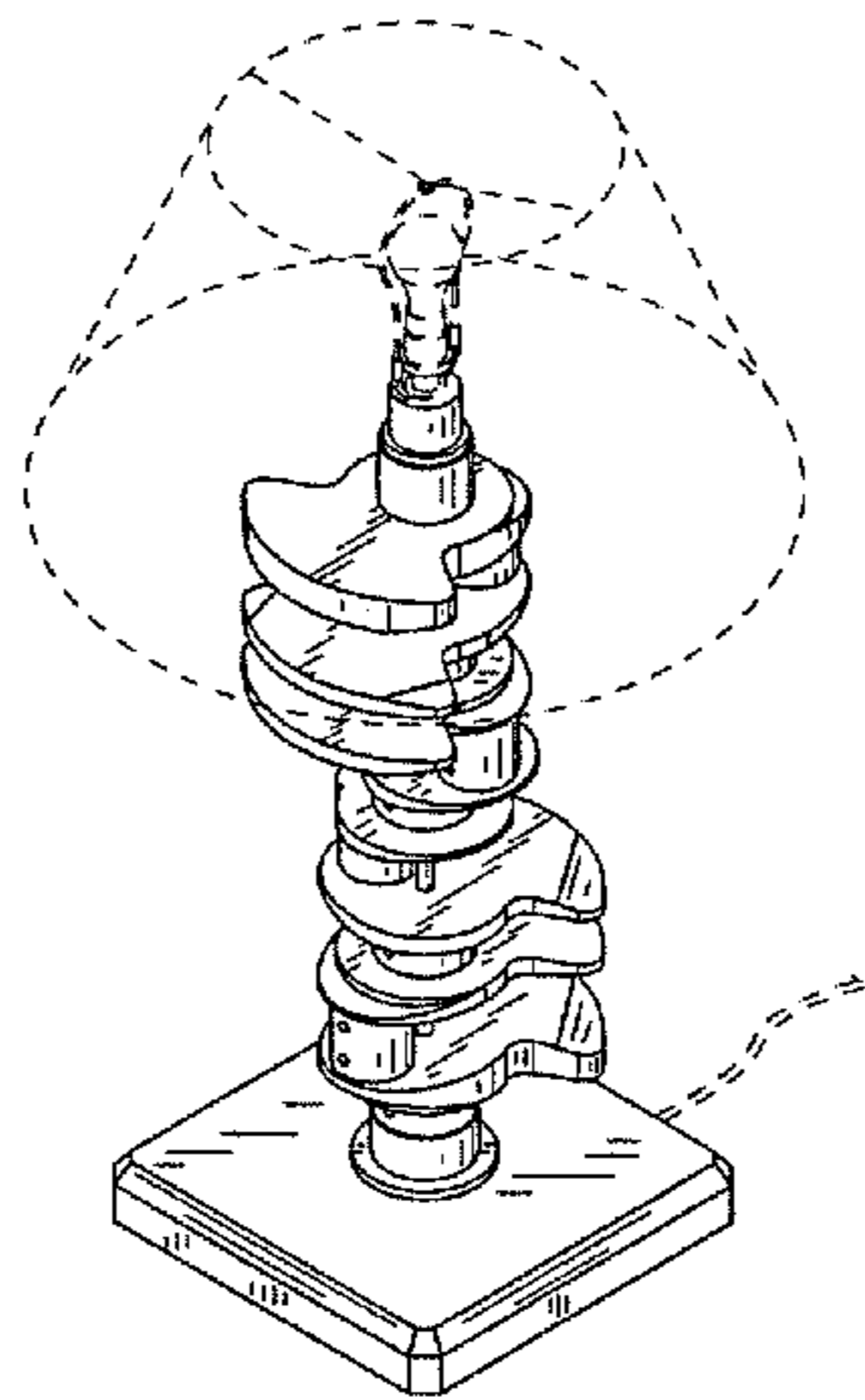

FIG. **13** is a rear elevation view of the design illustrated in FIG. **8**;

FIG. **14** is a left elevation view of the design illustrated in FIG. **8**;

FIG. **15** is a perspective view of a second alternative embodiment of the design illustrated in FIG. **1**, the only distinction being the omission of a base and the addition of a light fixture, it being understood that all other surfaces are the same as those in the first embodiment, the broken lines showing environment for illustrative purposes only and forming no part of the claimed design;

FIG. **16** is a bottom plan view of the design illustrated in FIG. **15**;

FIG. **17** is a top plan view of the design illustrated in FIG. **15**;

FIG. **18** is a front elevation view of the design illustrated in FIG. **15**;

FIG. **19** is a right elevation view of the design illustrated in FIG. **15**;

FIG. **20** is a rear elevation view of the design illustrated in FIG. **15**; and,

FIG. **21** is a left elevation view of the design illustrated in FIG. **15**.

1 Claim, 6 Drawing Sheets

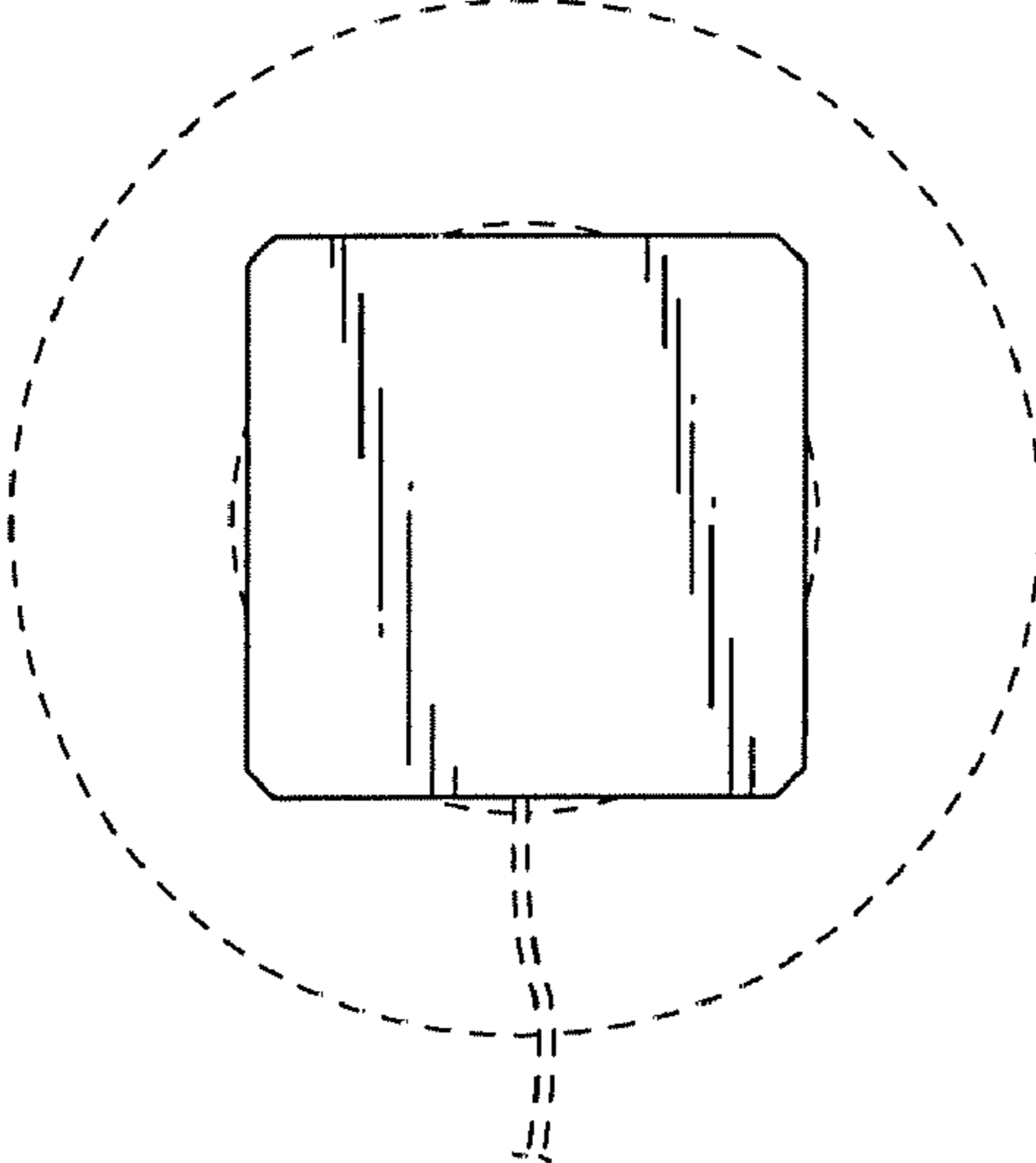

FIG. 2

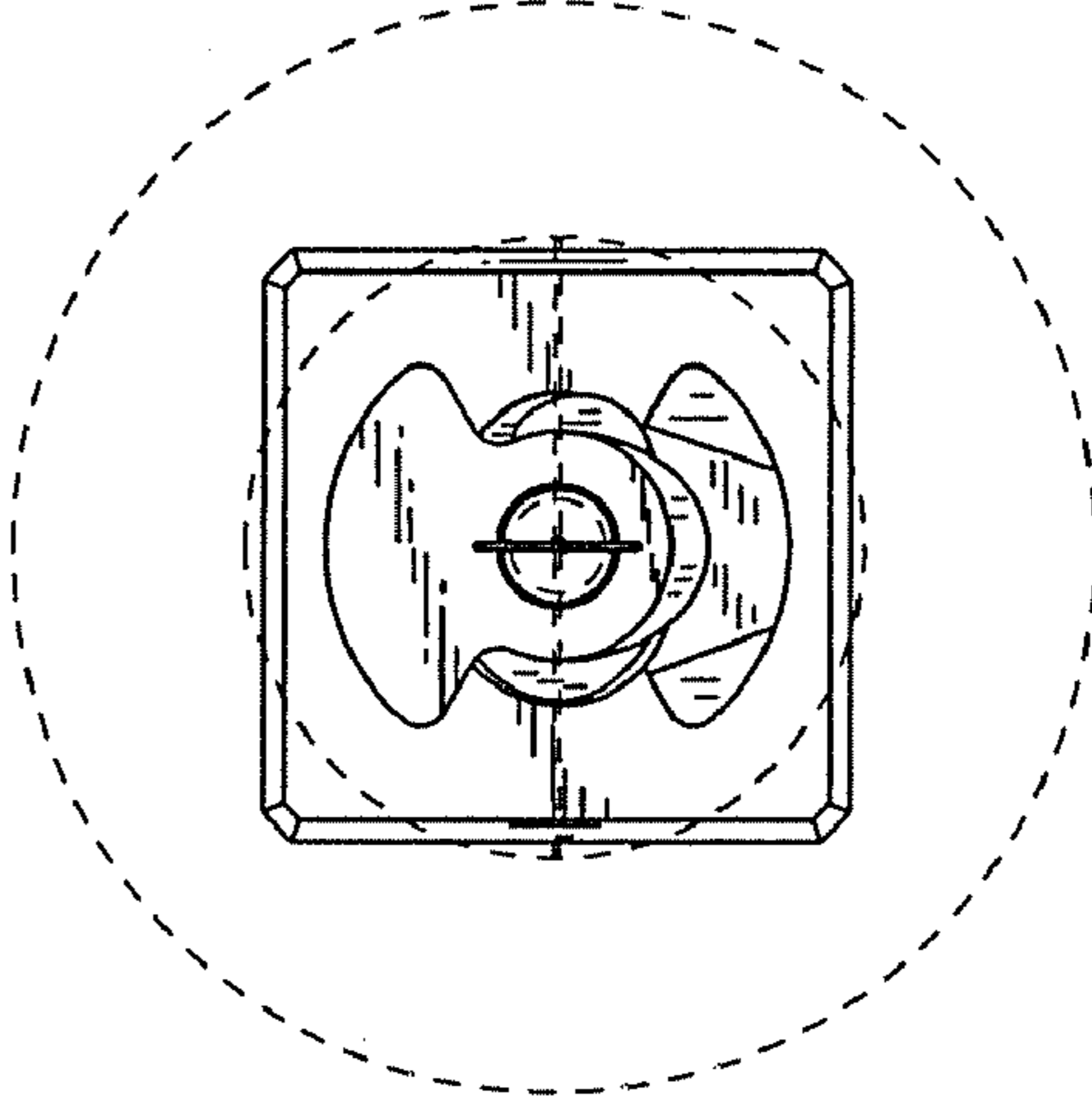

FIG. 3

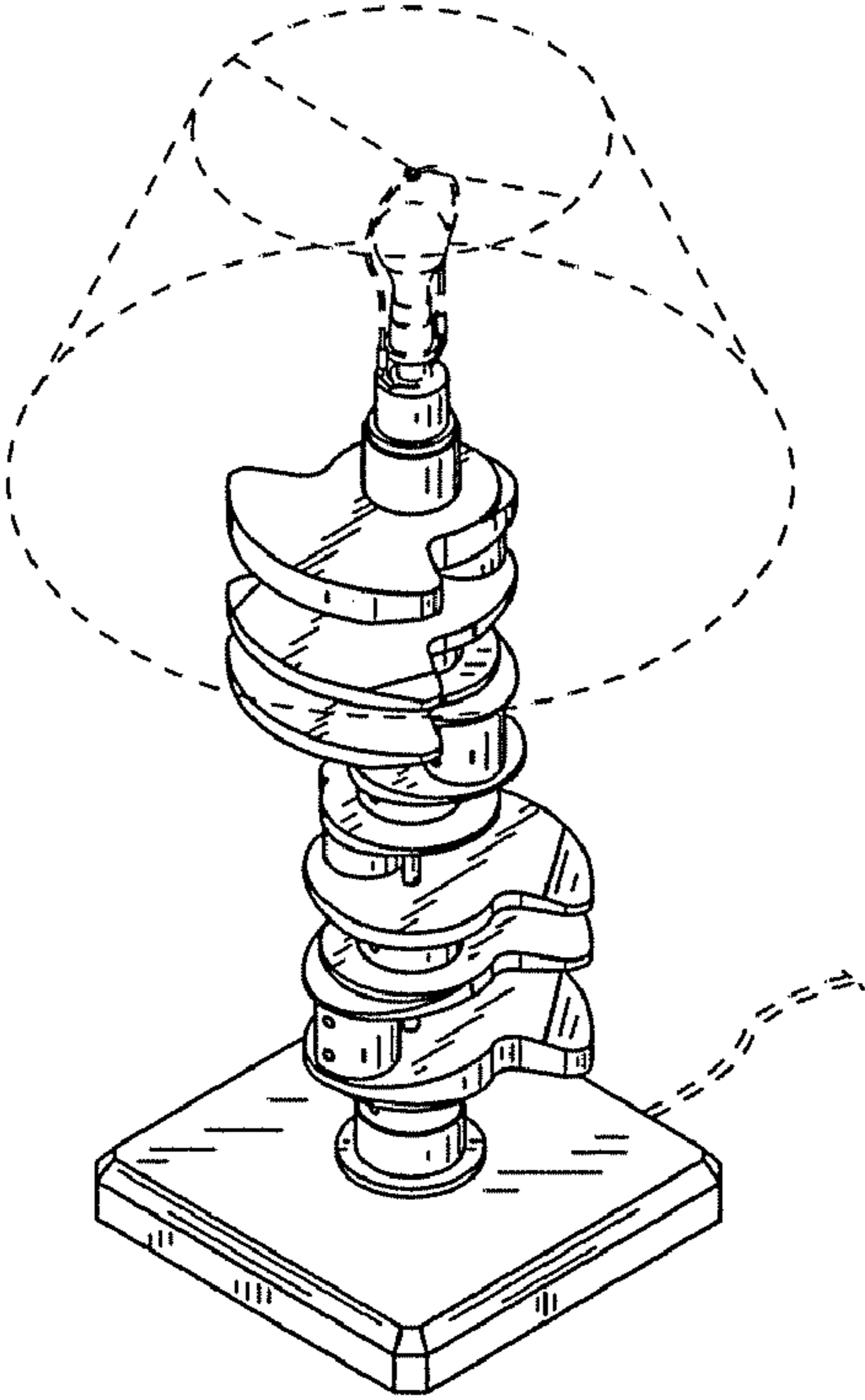

FIG. 1

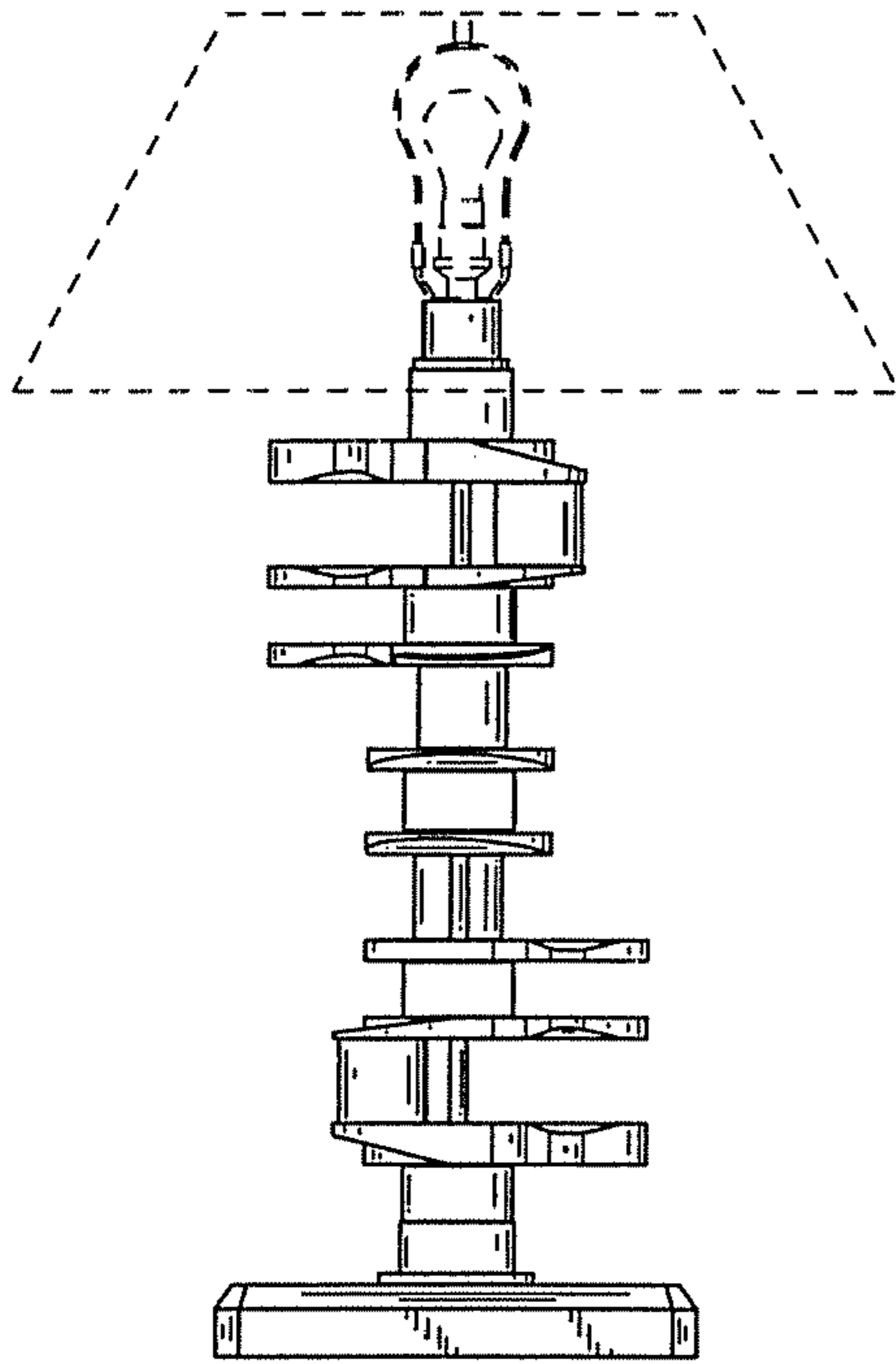

FIG.4

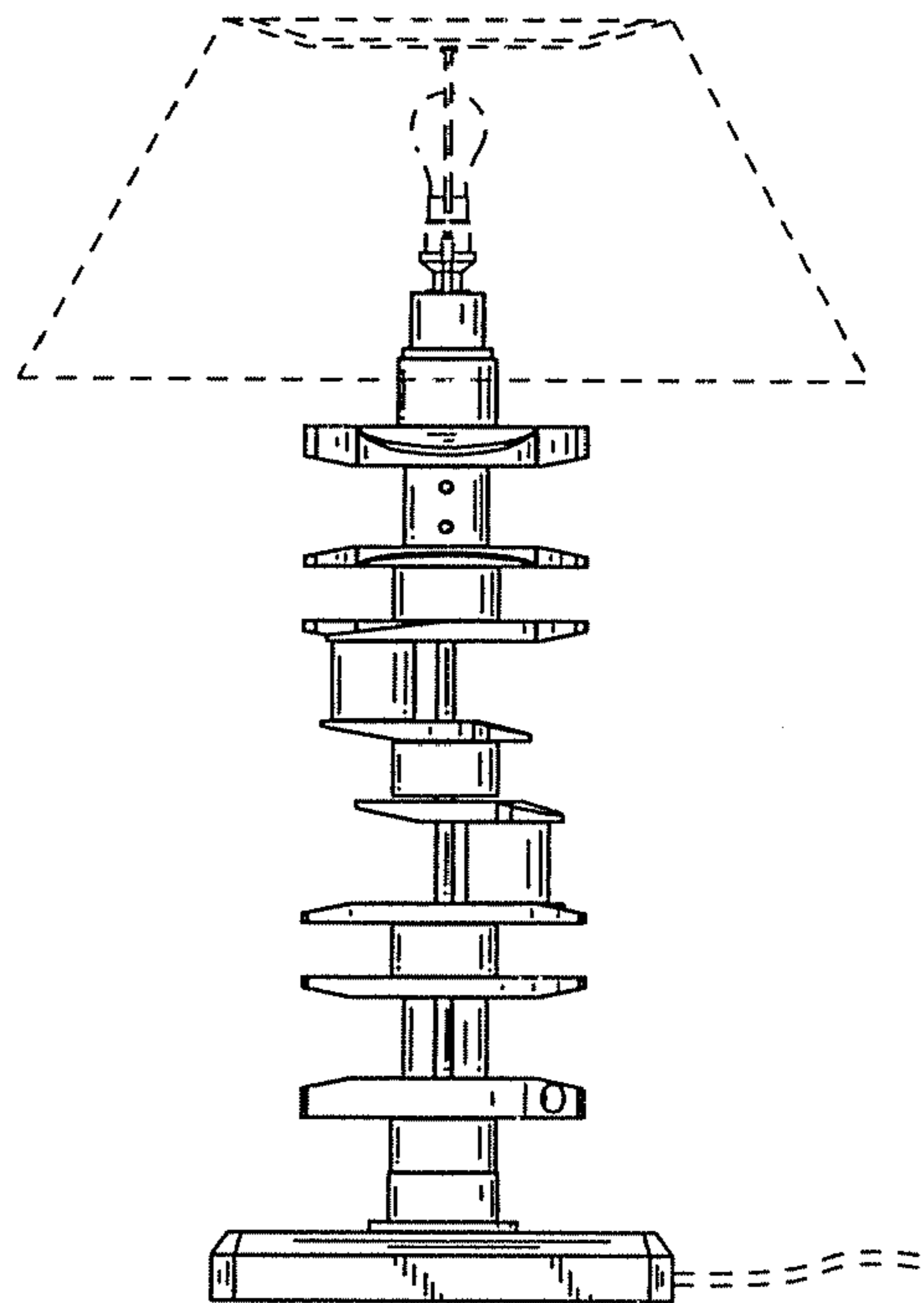

FIG.5

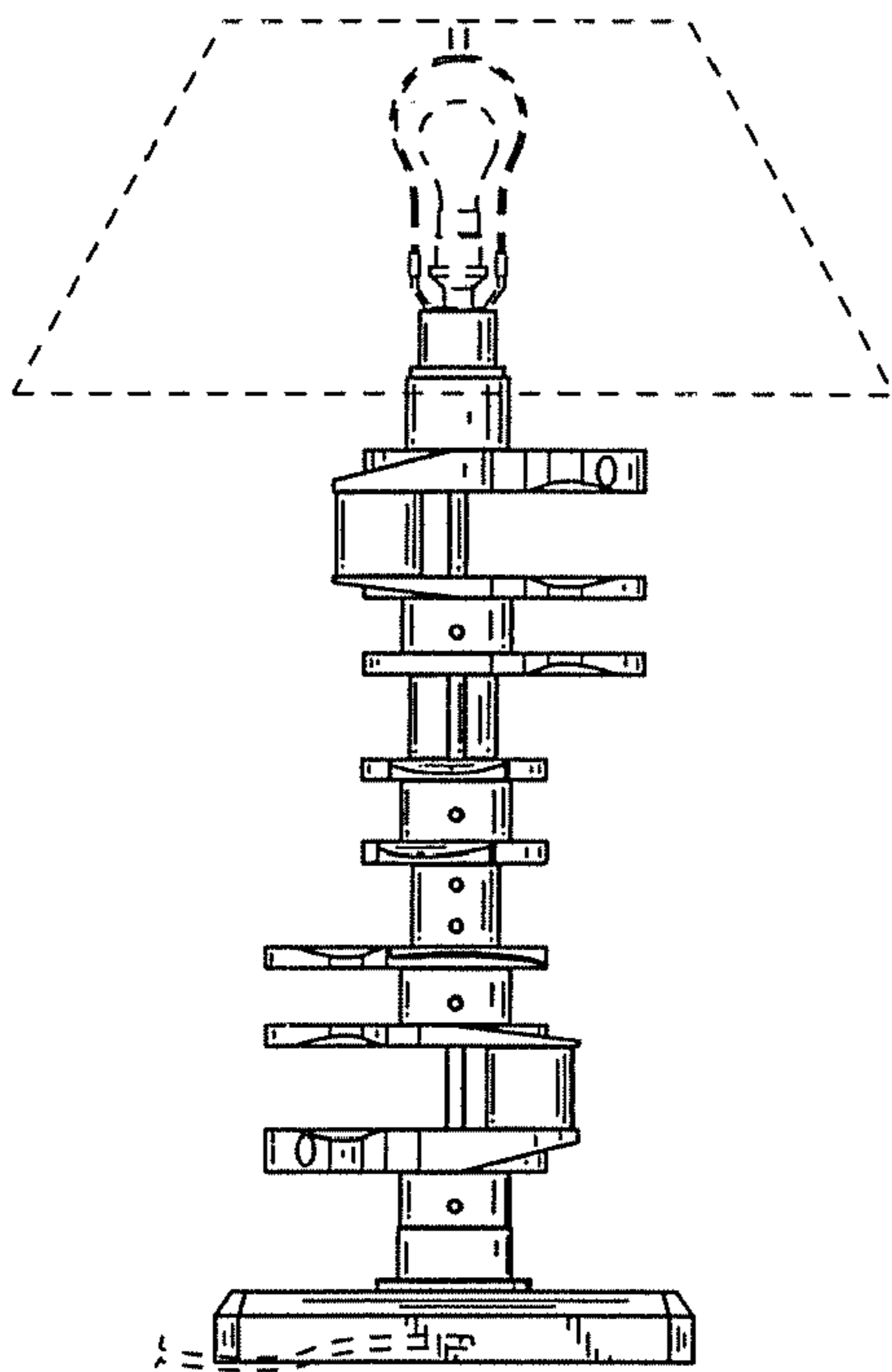

FIG.6

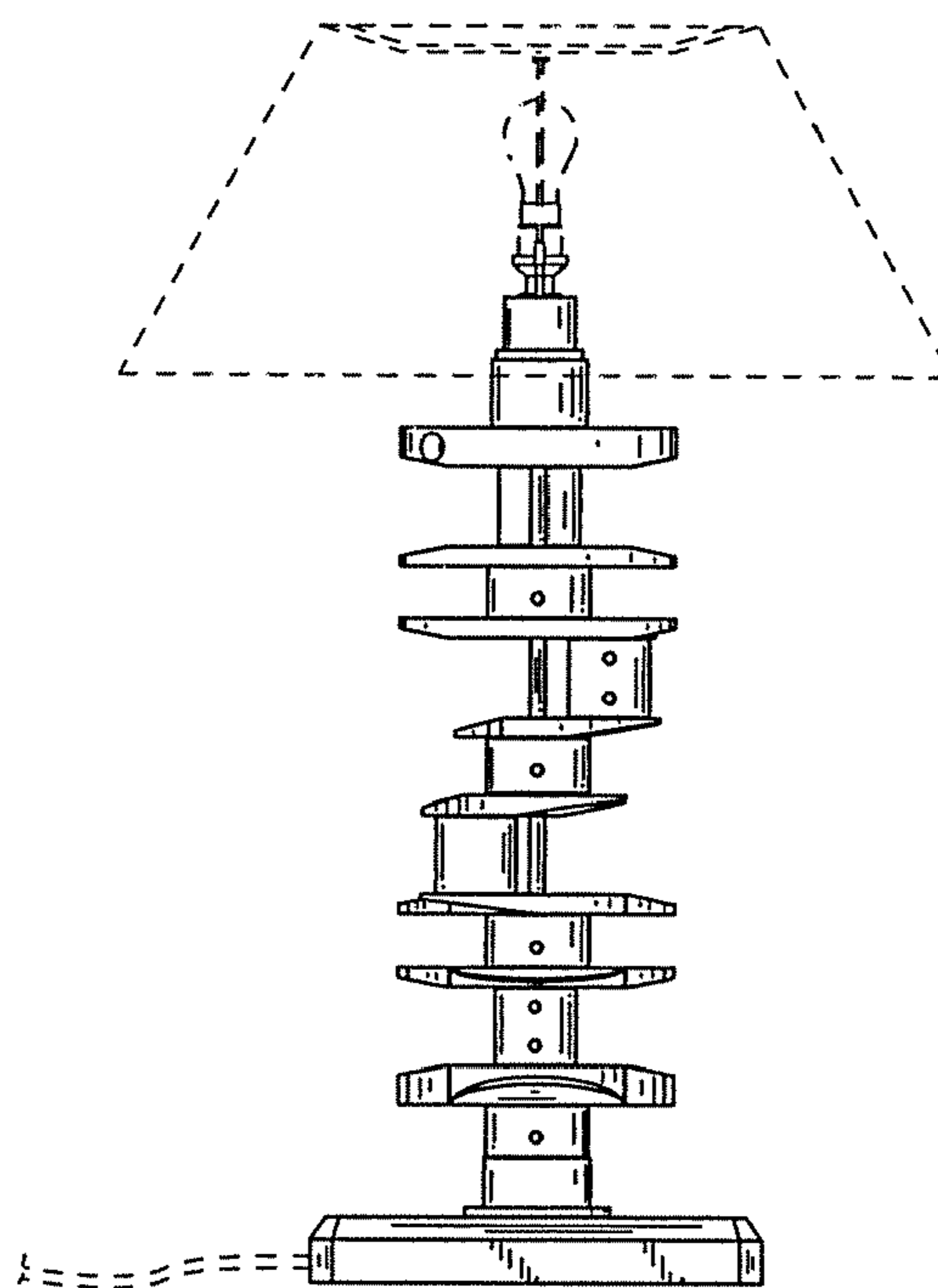

FIG.7

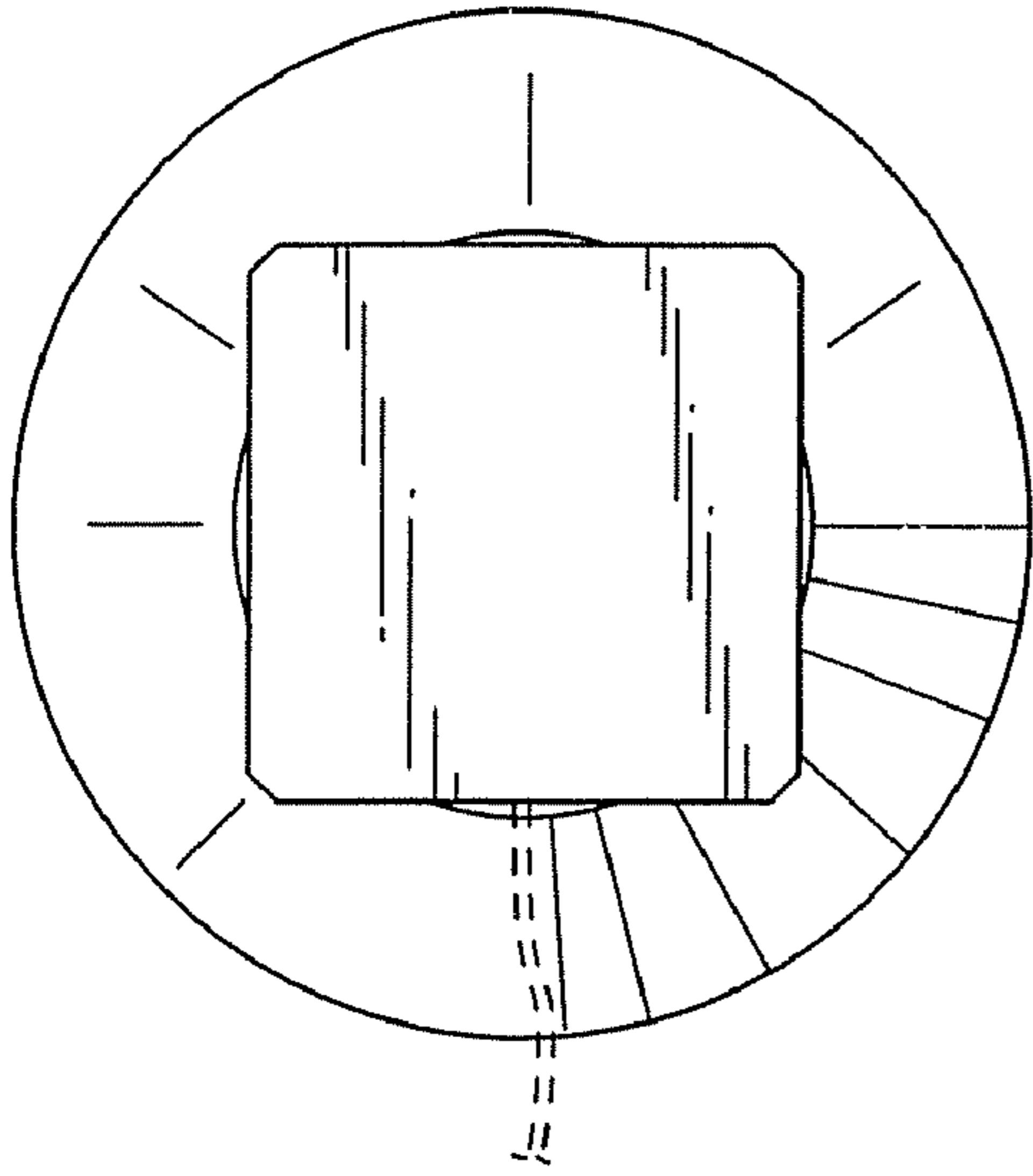

FIG. 9

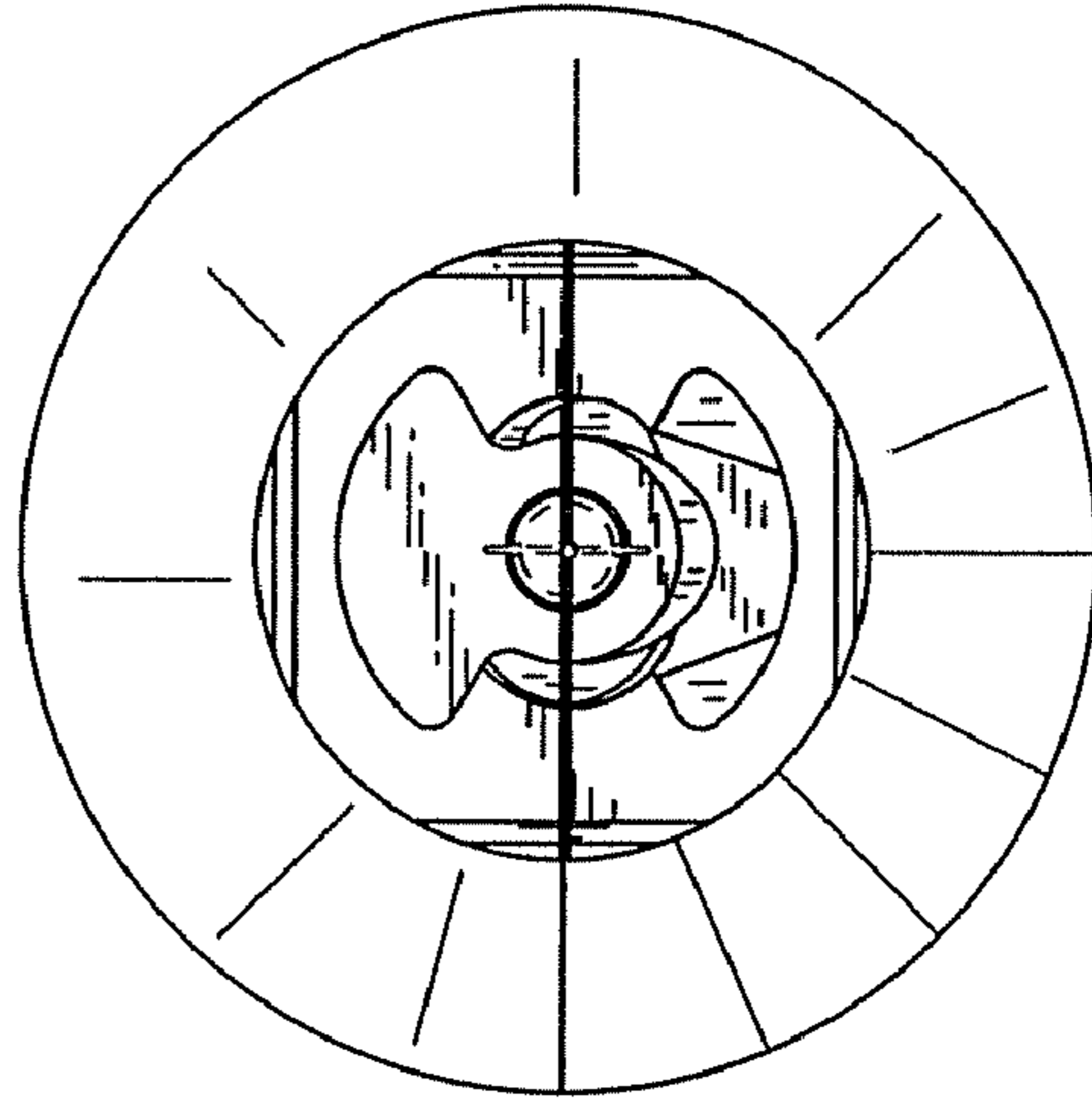

FIG. 10

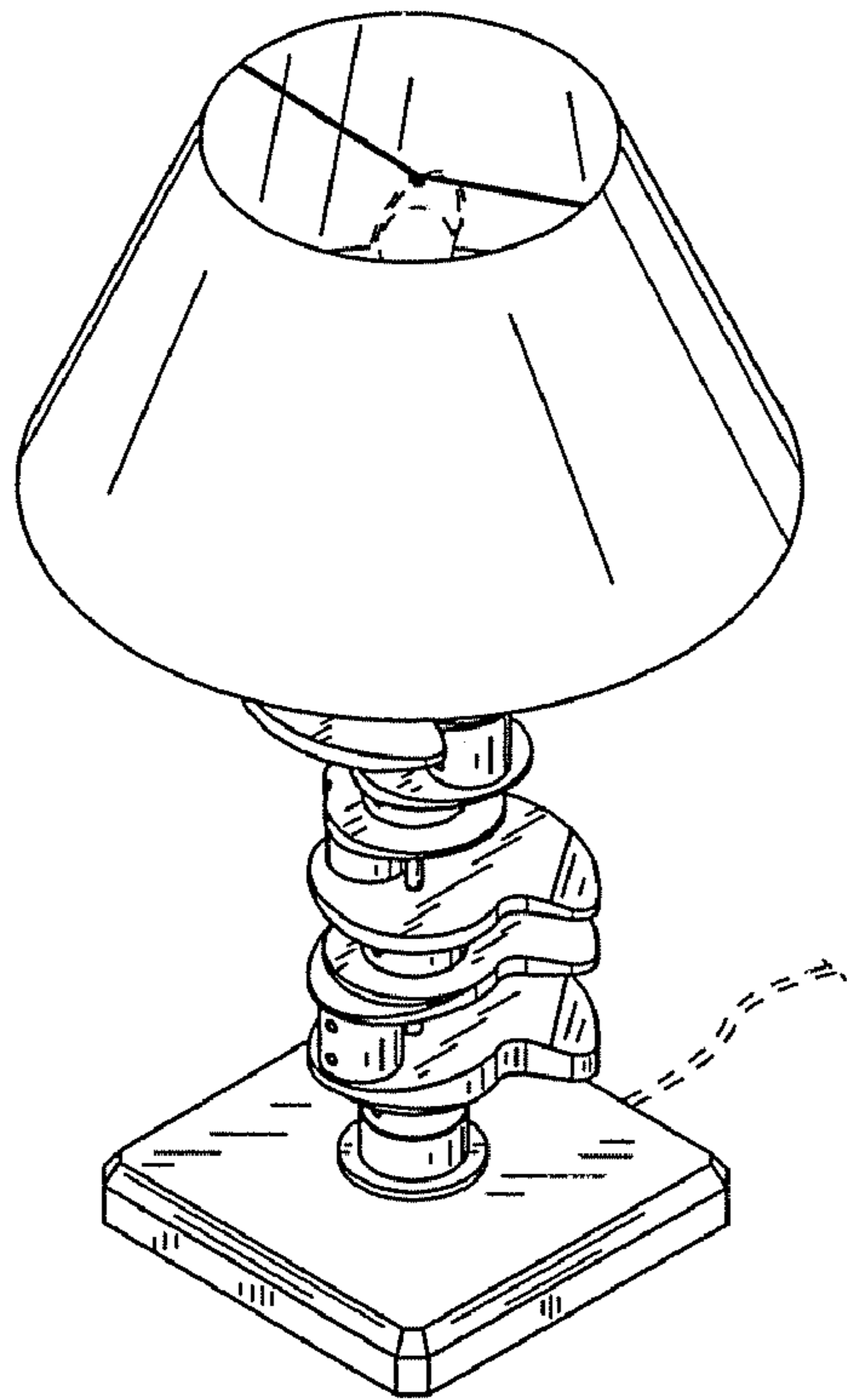

FIG. 8

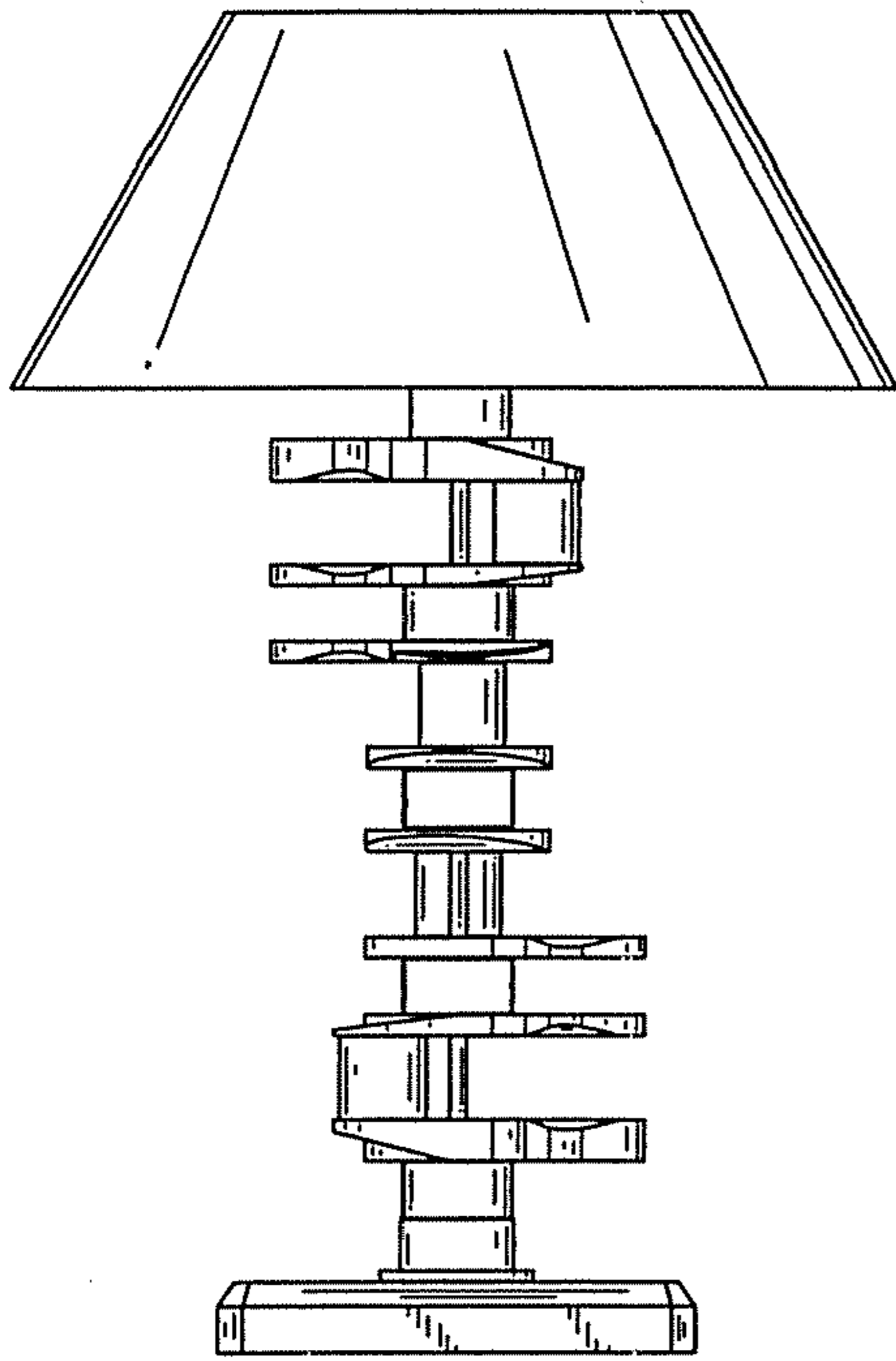

FIG. 11

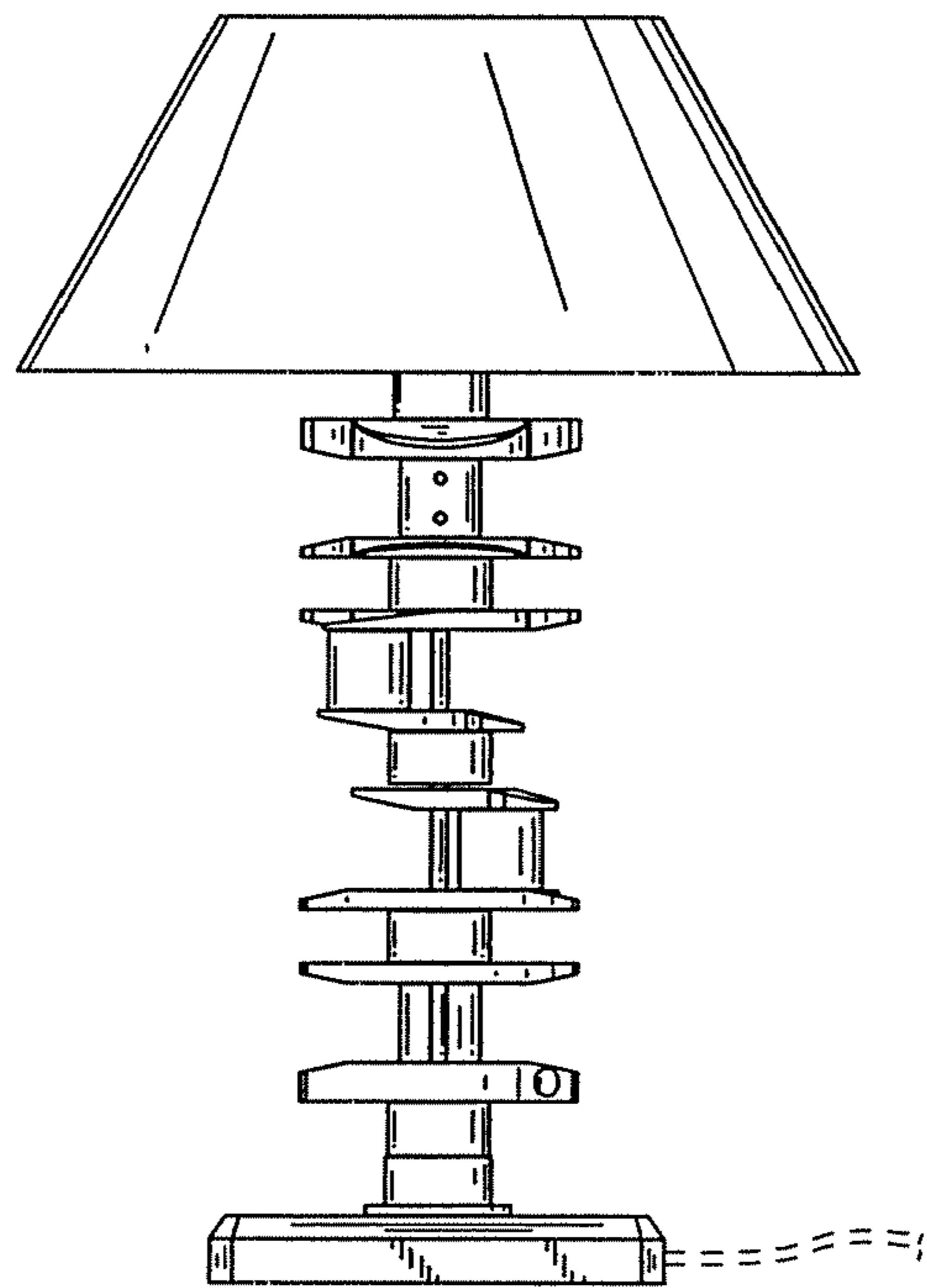

FIG. 12

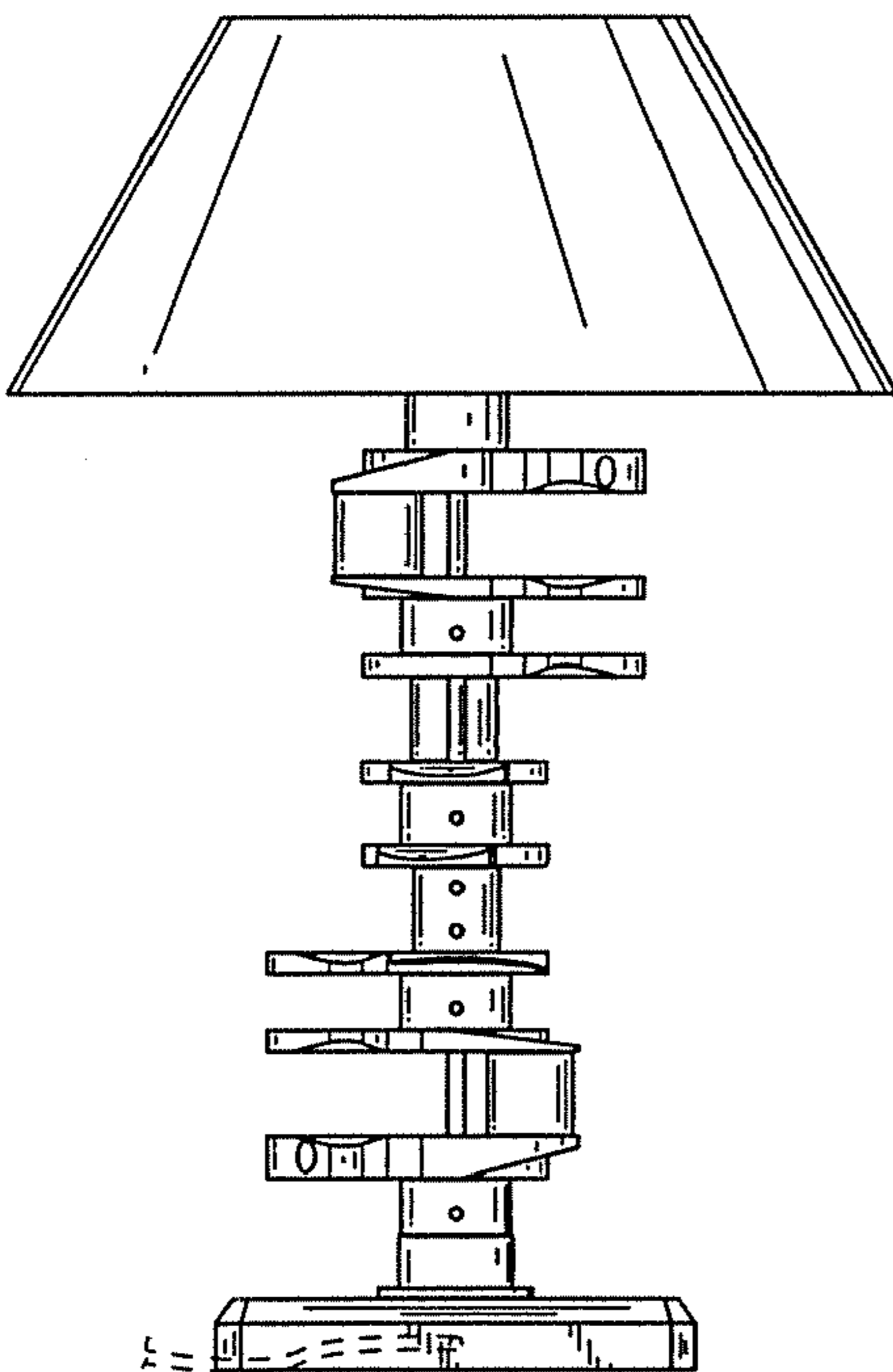

FIG. 13

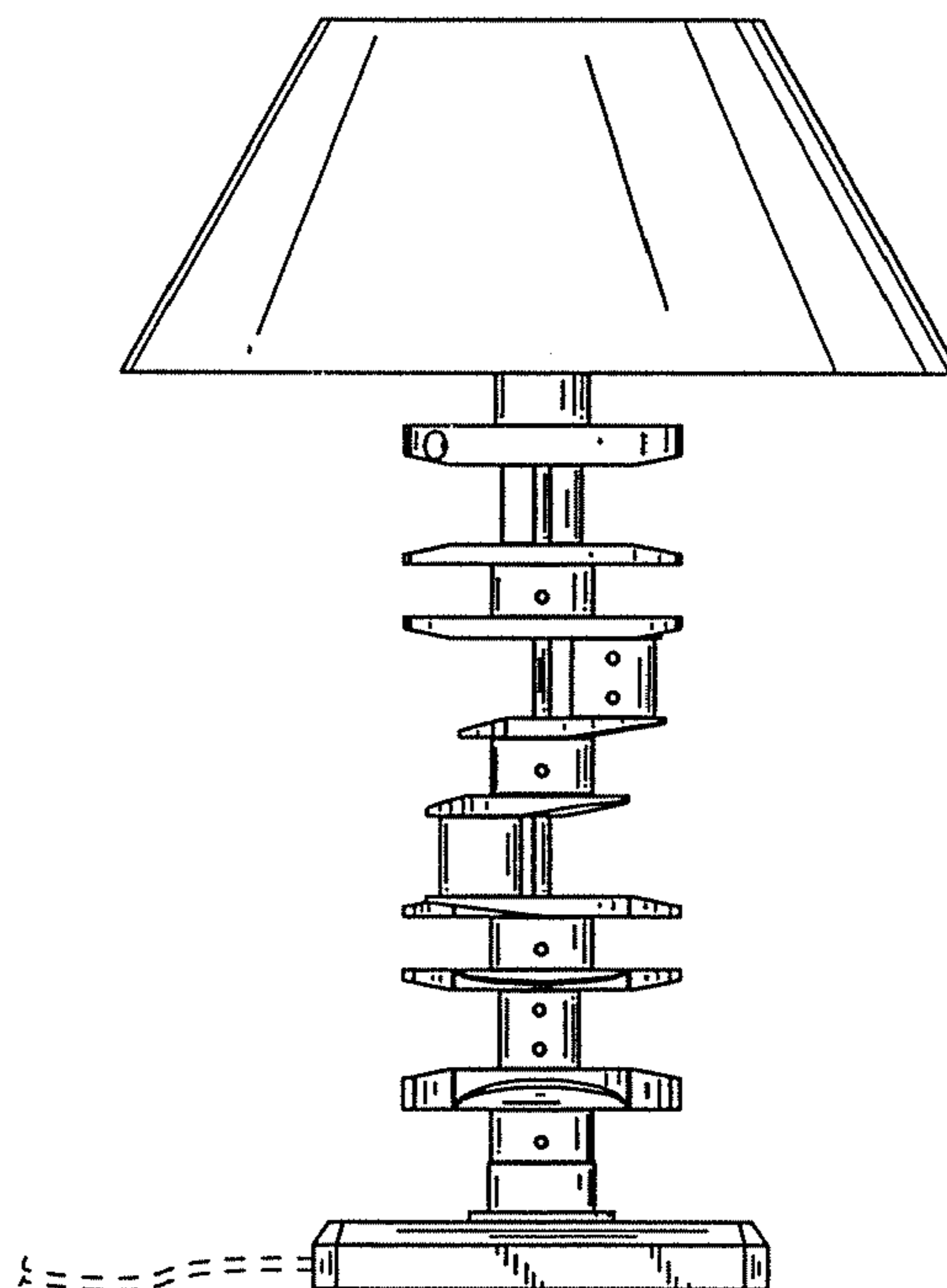

FIG. 14

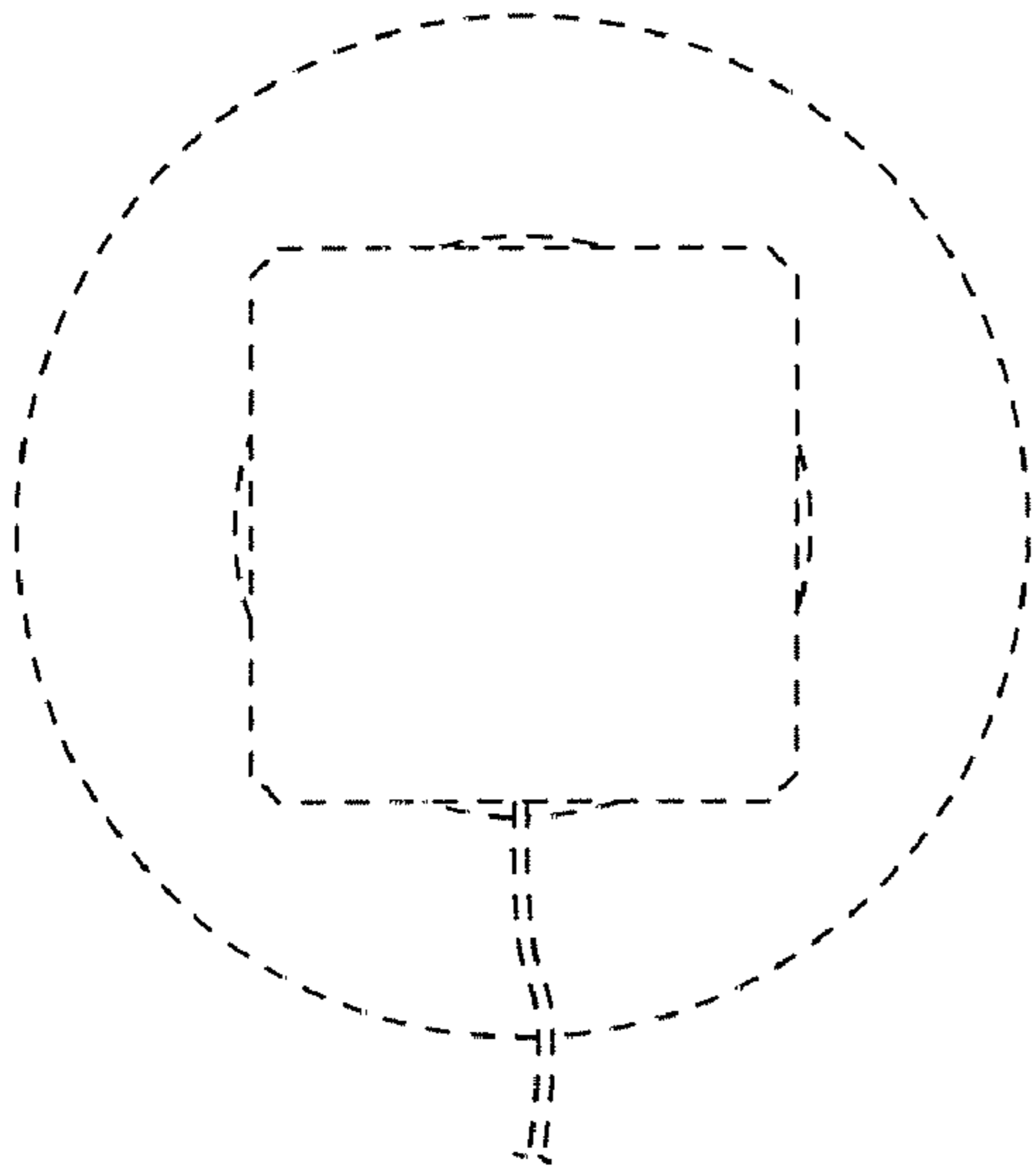

FIG.16

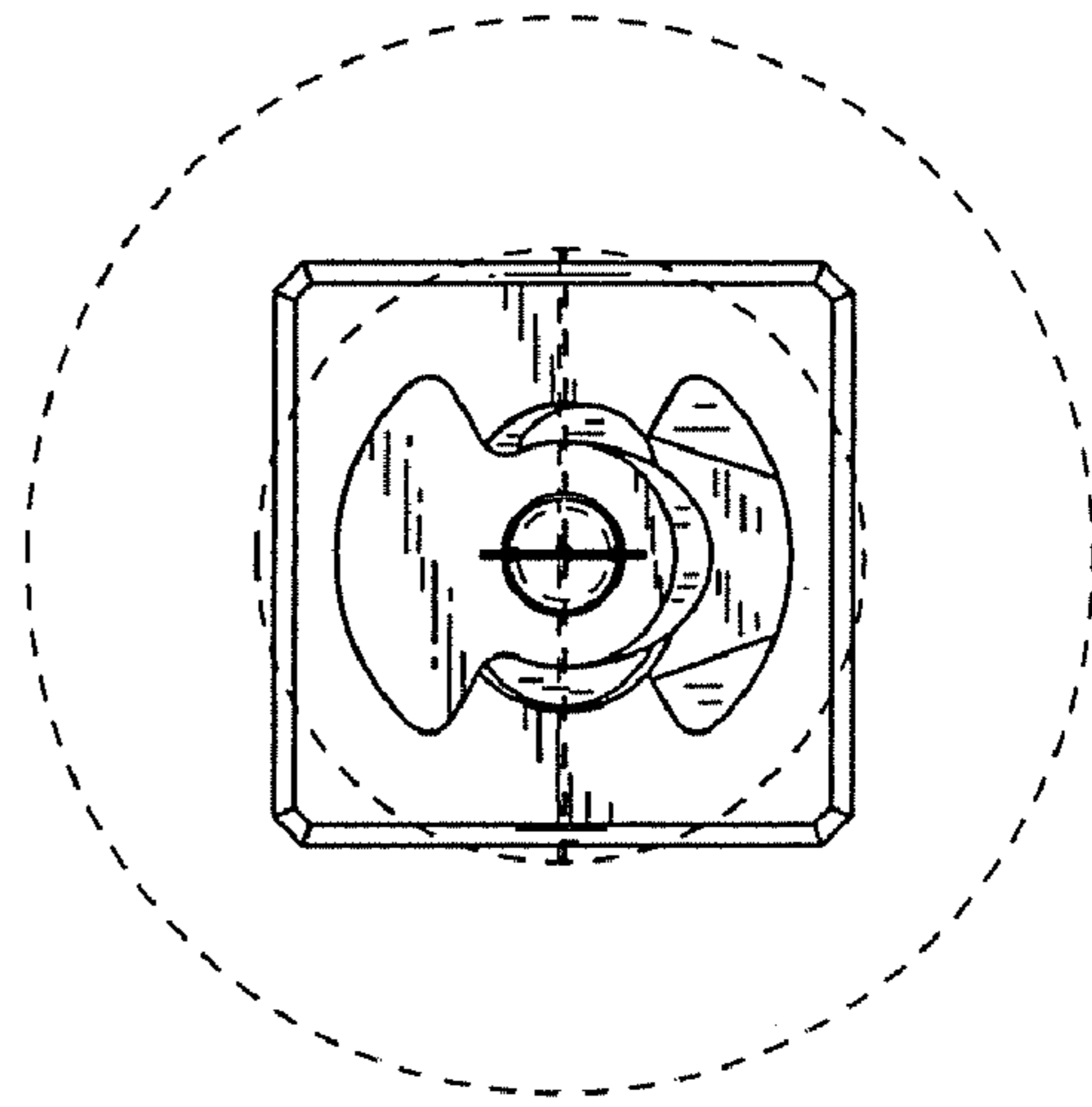

FIG.17

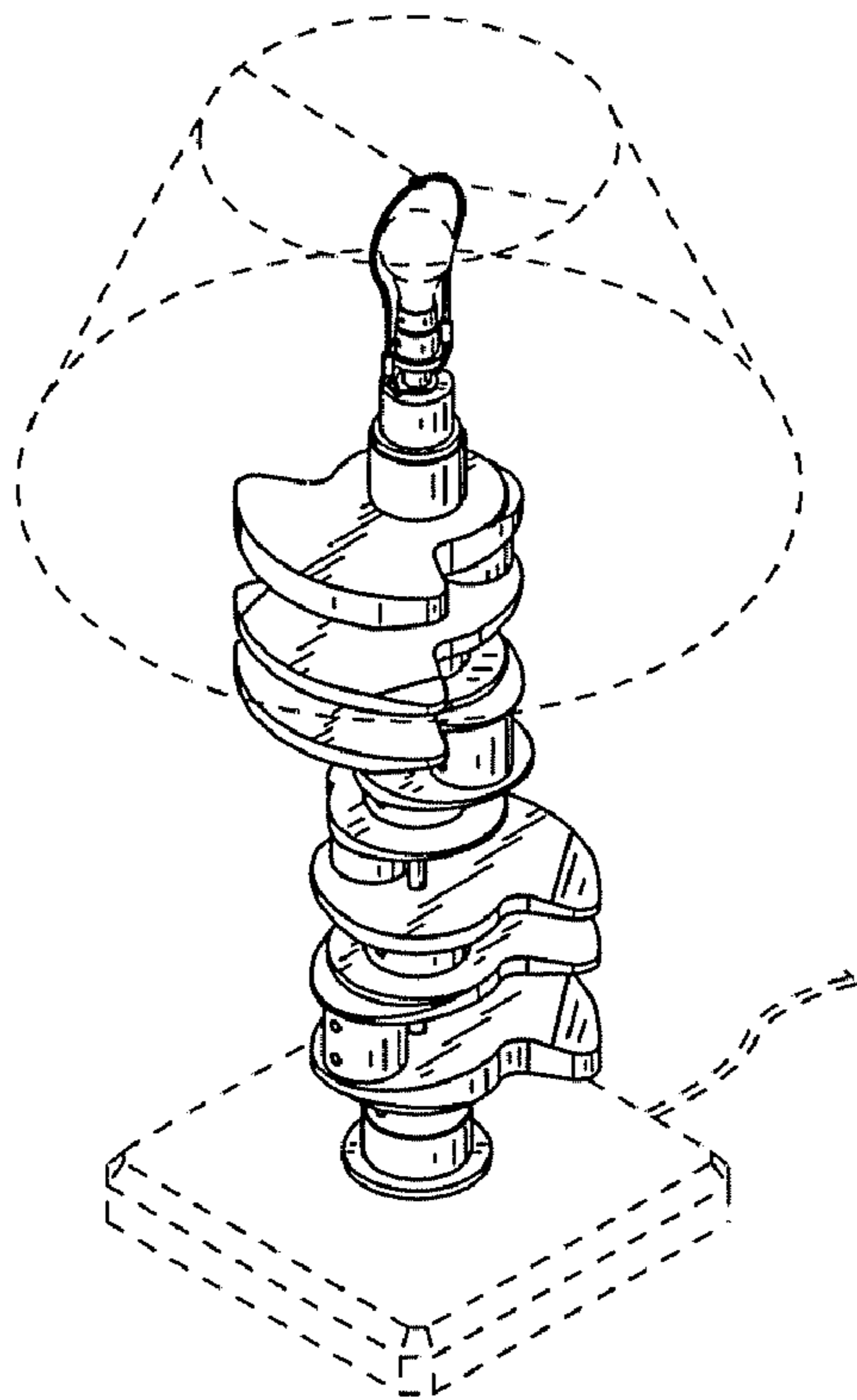

FIG.15

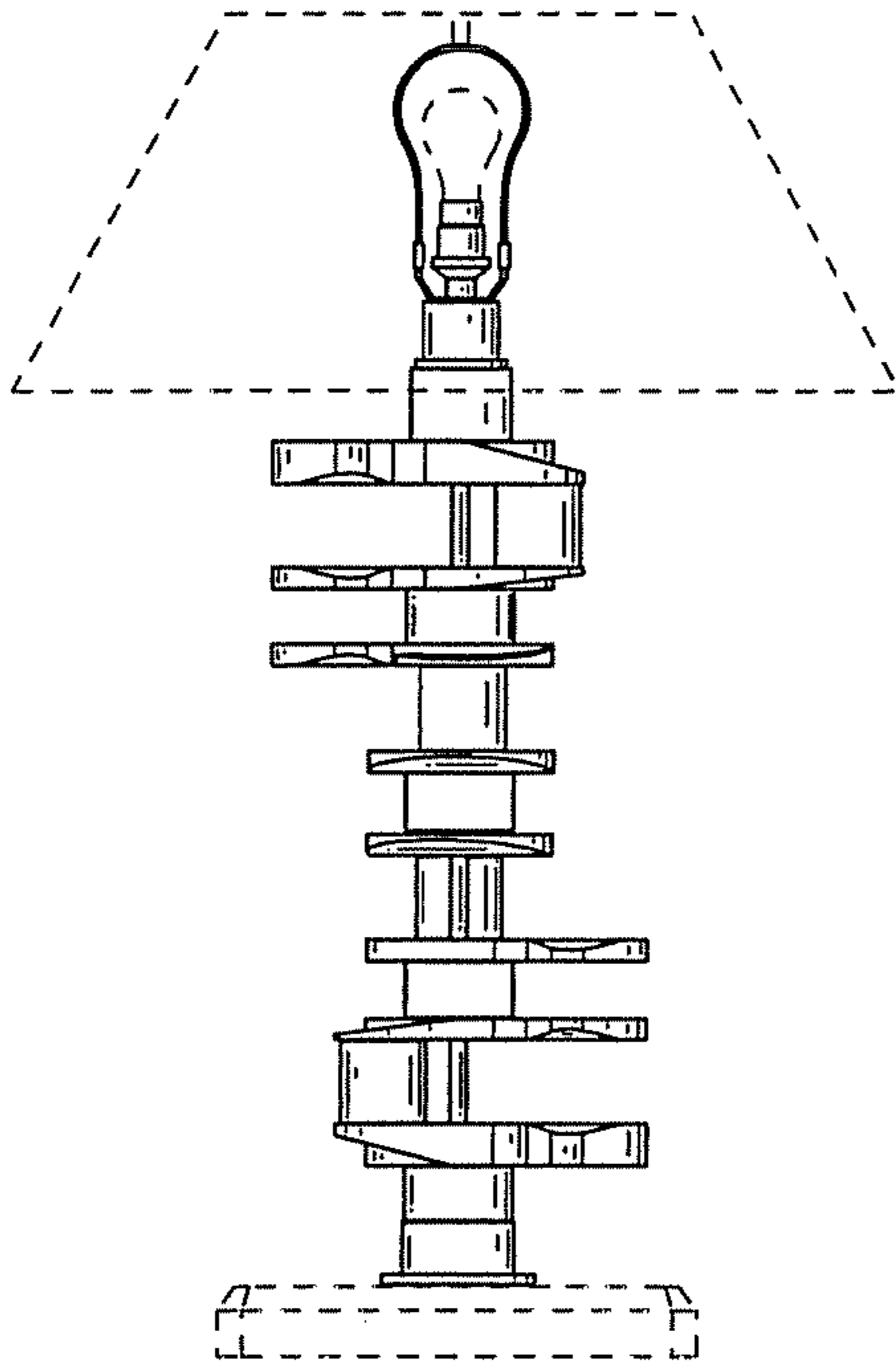

FIG.18

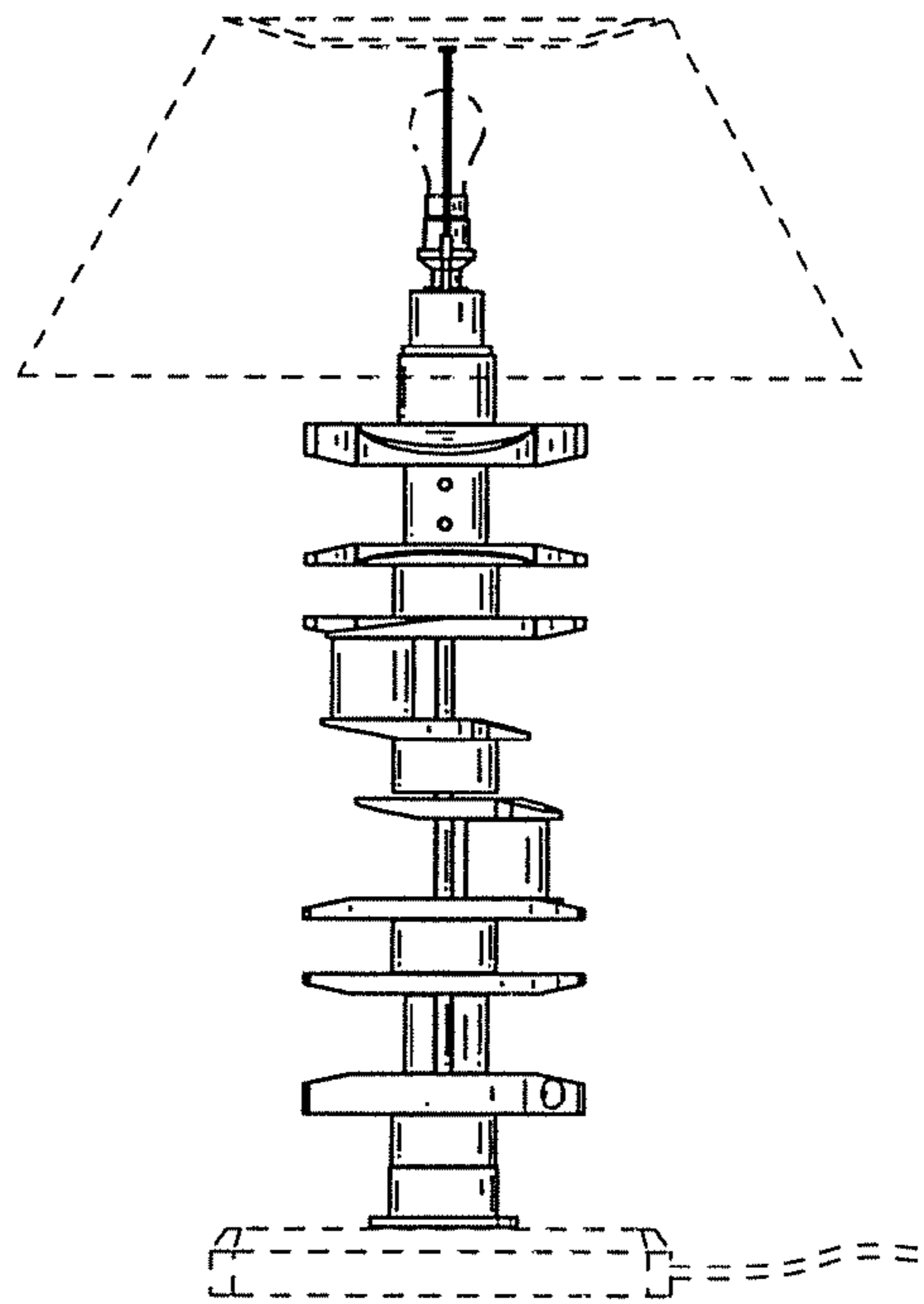

FIG.19

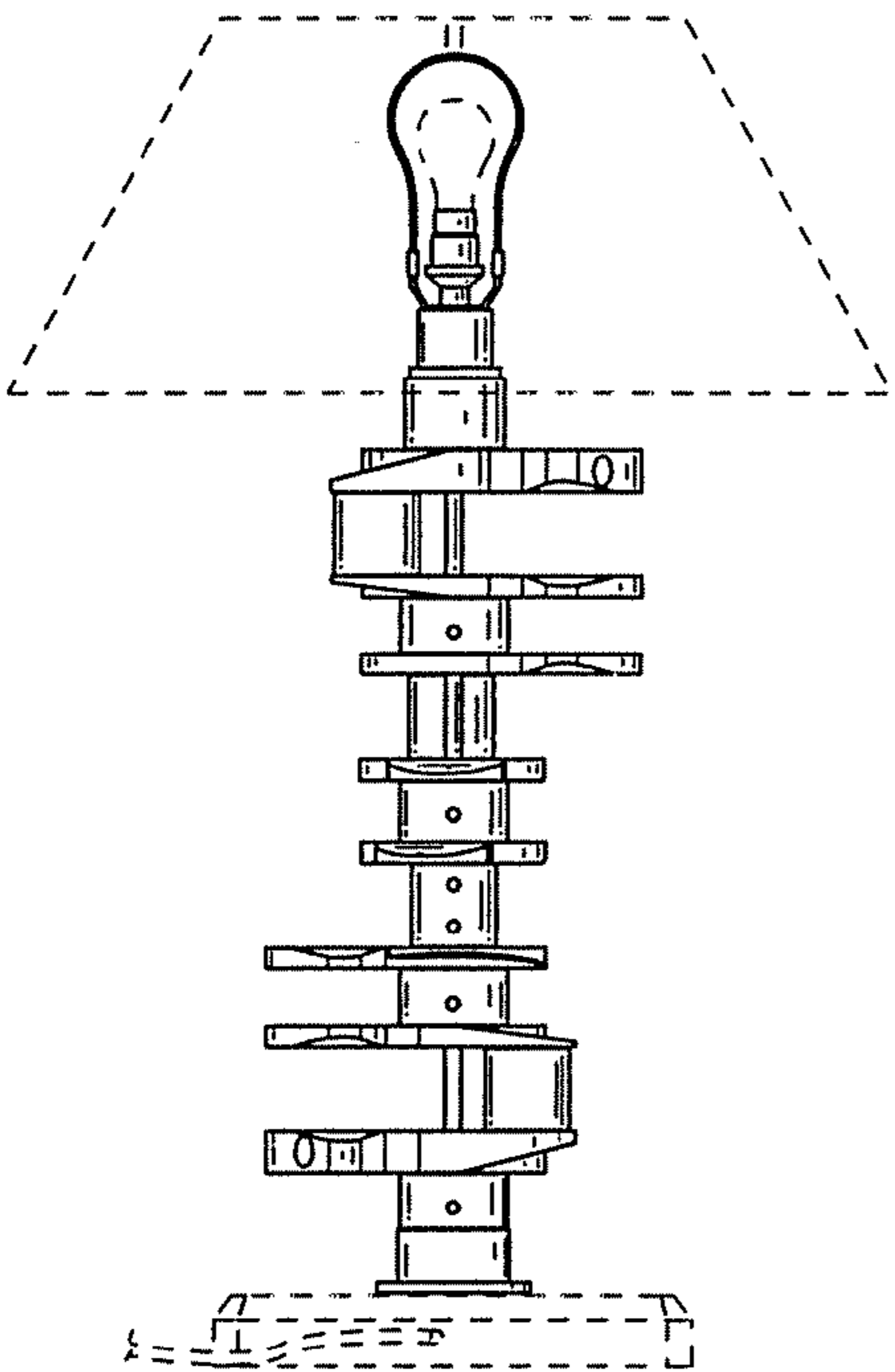

FIG.20

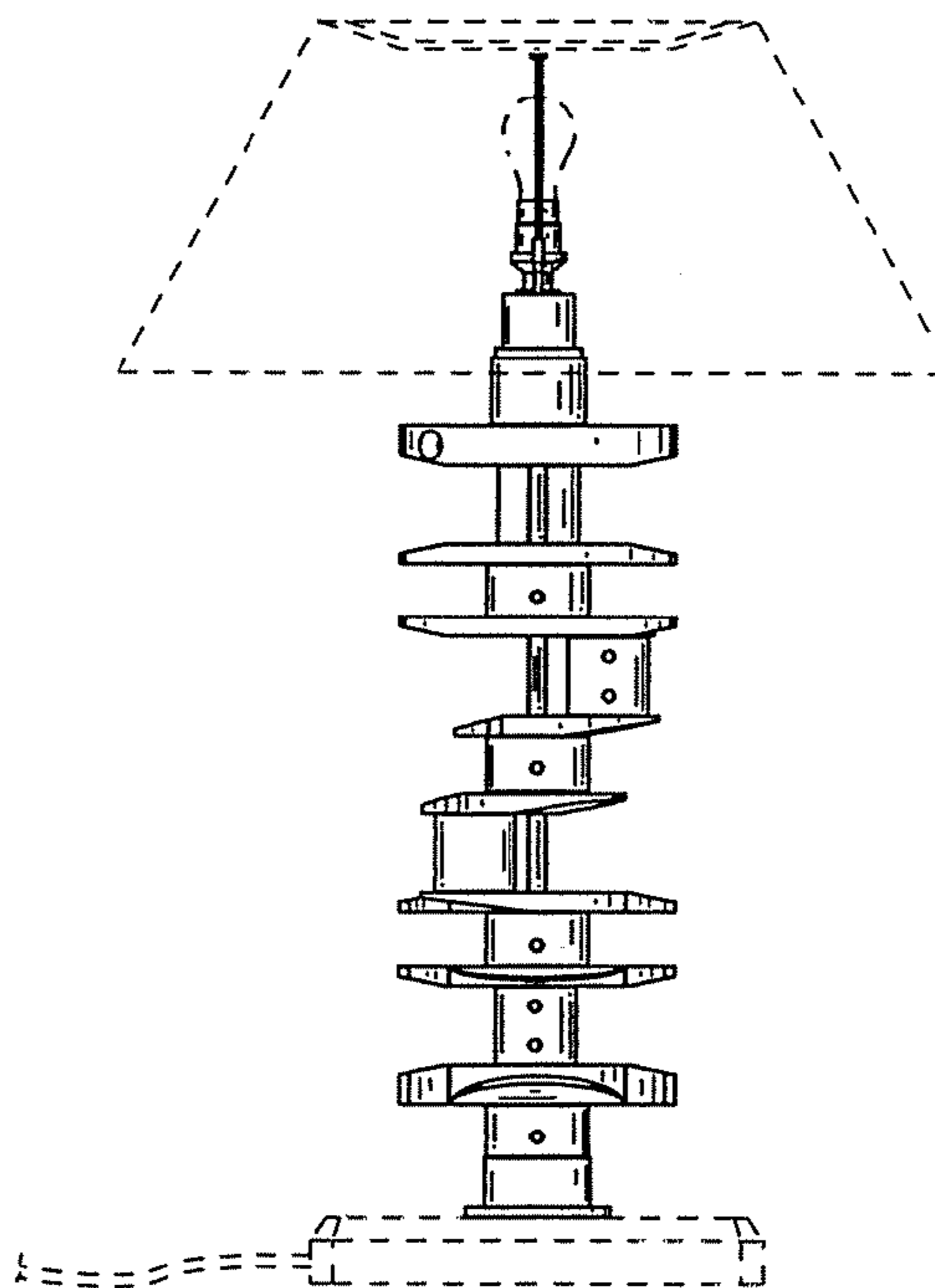

FIG.21