



US00D560709S

(12) **United States Design Patent**
Unkert

(10) **Patent No.:** **US D560,709 S**
(45) **Date of Patent:** **** Jan. 29, 2008**

(54) **GUITAR HEADSTOCK**

- (75) Inventor: **Paul Unkert**, Toms River, NJ (US)
- (73) Assignee: **UNK Guitars, LLC.**, Toms River, NJ (US)
- (**) Term: **14 Years**
- (21) Appl. No.: **29/274,825**
- (22) Filed: **May 30, 2007**

- (51) **LOC (8) Cl.** **17-03**
- (52) **U.S. Cl.** **D17/20**
- (58) **Field of Classification Search** D17/14,
D17/15, 18, 19, 20; 84/7, 173, 267, 268,
84/269, 275, 277, 284, 285, 290, 291, 293,
84/306, 314, 453
See application file for complete search history.

(56) **References Cited**

U.S. PATENT DOCUMENTS

474,120	A	*	5/1892	Ganss	84/267
D33,685	S	*	12/1900	Behee	D17/19
1,880,923	A	*	10/1932	Eisenhour	84/457
D181,865	S	*	1/1958	McCarty	D17/14
4,121,492	A	*	10/1978	Berardi et al.	84/293
D274,734	S	*	7/1984	Sowle	D17/14
4,651,740	A	*	3/1987	Schroepfel	607/31
D299,650	S	*	1/1989	Mitchell	D14/162
4,890,529	A	*	1/1990	Grant	84/291
D313,036	S	*	12/1990	Wintz	D17/20
D318,062	S	*	7/1991	Tornese	D17/20

OTHER PUBLICATIONS

Bacon et al. Electric Guitars: The illustrated Encyclopedia. Copyright 2000. p. 290. Vaccaro Stingray (1999): Botom Center of page.*
 Bacon et al. Electric Guitars: The Illustrated Encyclopedia. Copyright 2000. p. 255. Kramer Guitars (1977): Bottom center of page.*

* cited by examiner

Primary Examiner—Ian Simmons
Assistant Examiner—R. Johnson

(74) *Attorney, Agent, or Firm*—Mattingly, Stanger, Malur & Brundidge, PC.

(57) **CLAIM**

The ornamental design for a guitar headstock, as shown and described.

DESCRIPTION

FIG. 1 is a perspective view of a guitar headstock showing the new design;

FIG. 2 is a top plan view thereof;

FIG. 3 is a bottom plan view thereof;

FIG. 4 is a left side elevational thereof;

FIG. 5 is a right side elevational thereof;

FIG. 6 is a front elevational view thereof; and,

FIG. 7 is a rear elevational view thereof.

The broken lines in FIG. 1 are shown to illustrate the environment of the guitar headstock and form no part of the claimed design.

1 Claim, 4 Drawing Sheets

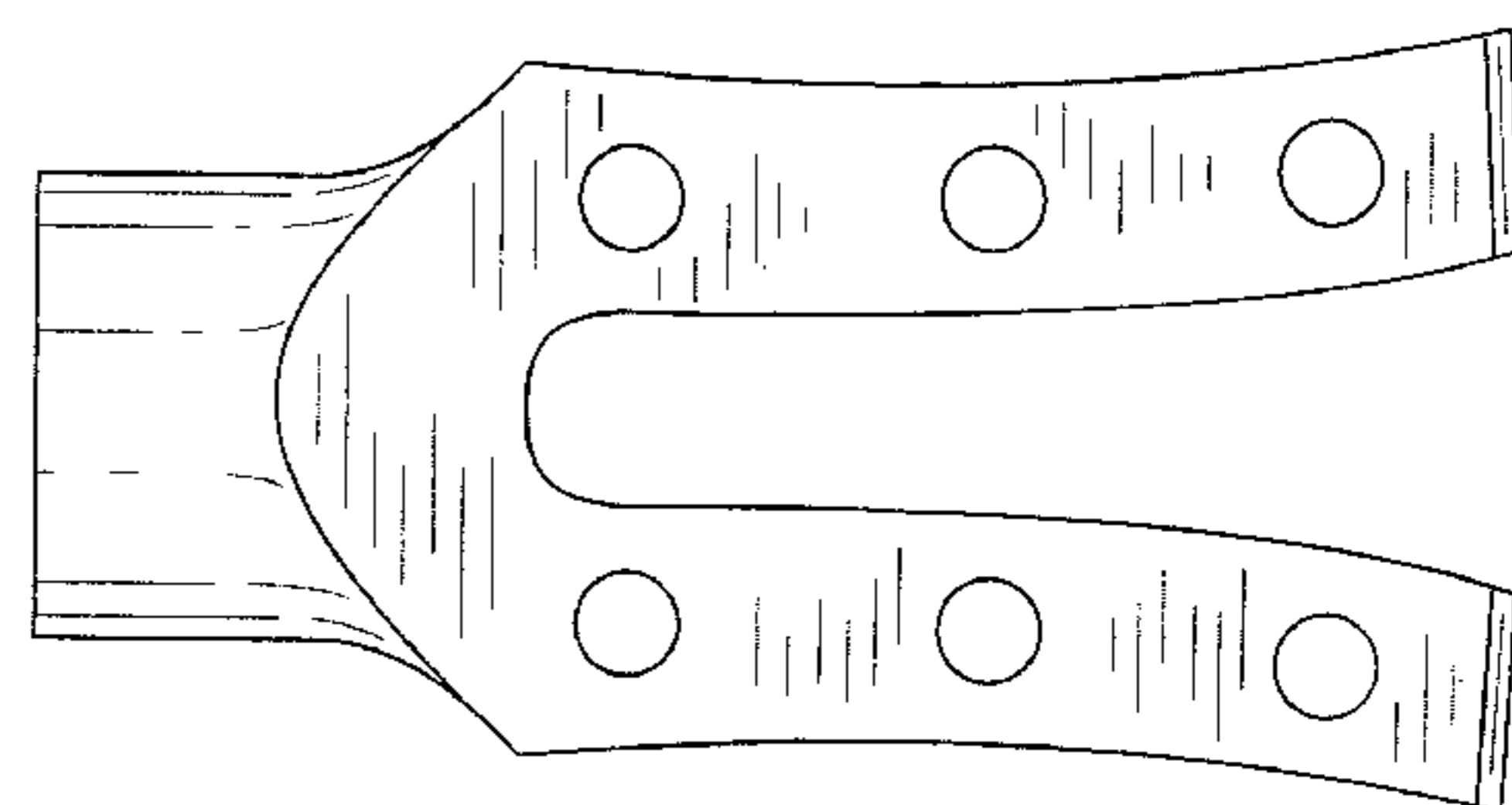
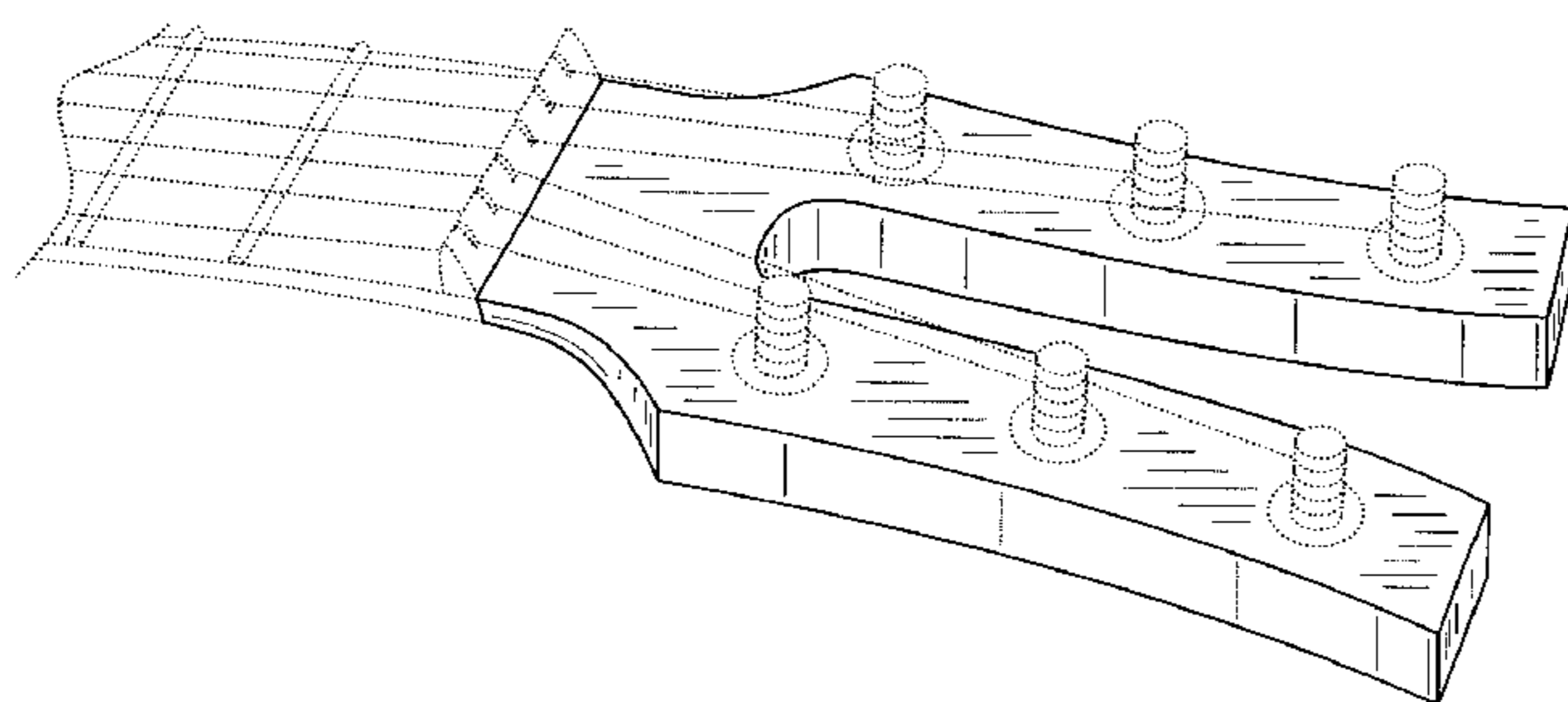

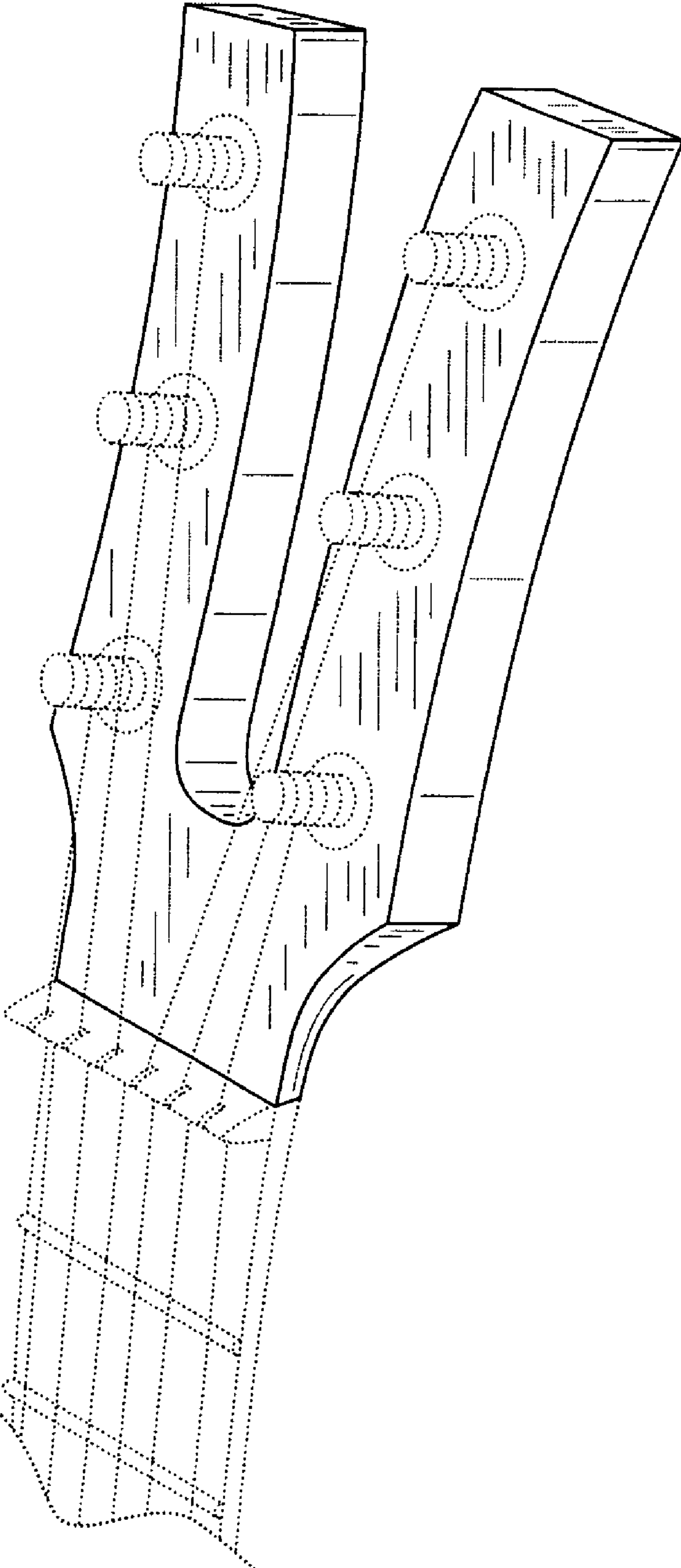

FIG. 1

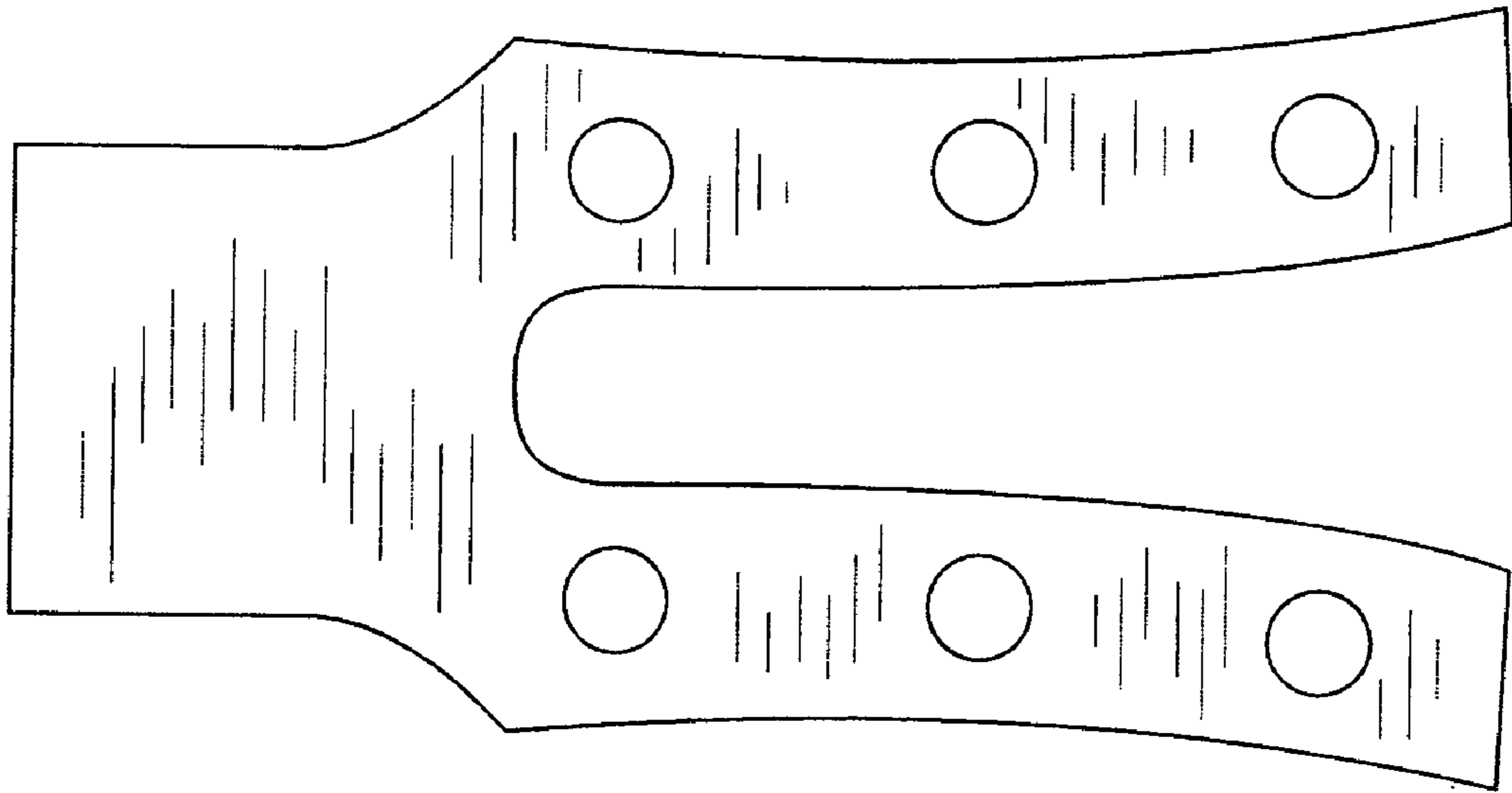

FIG. 2

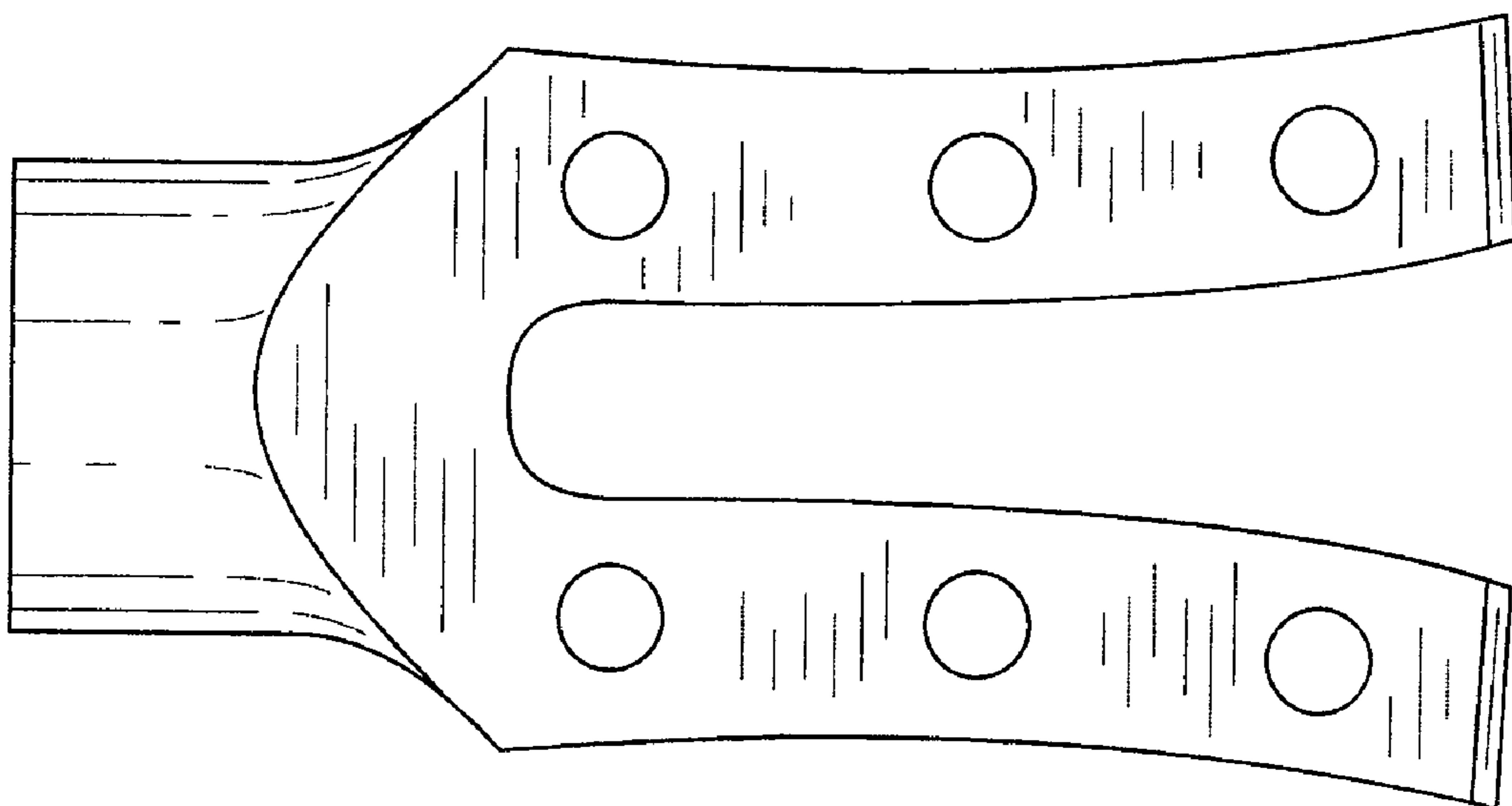

FIG. 3

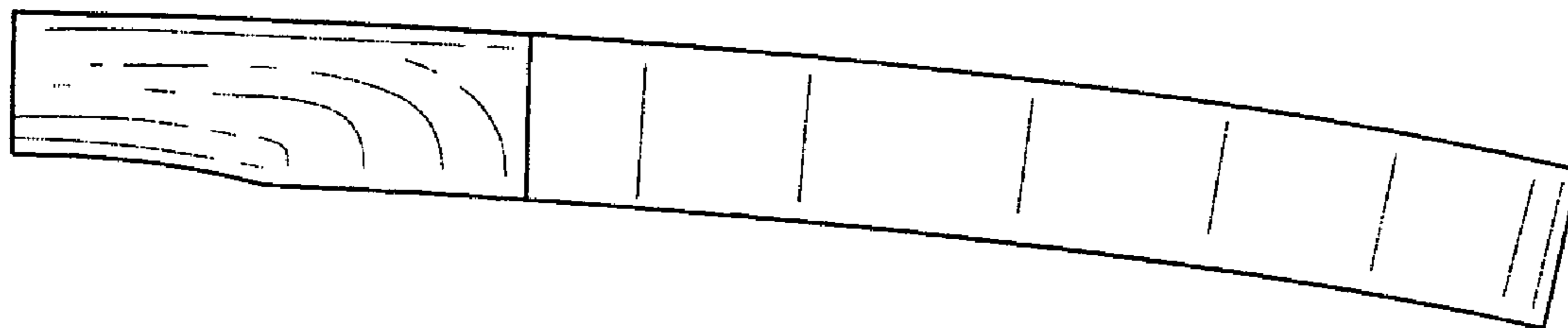

FIG. 4

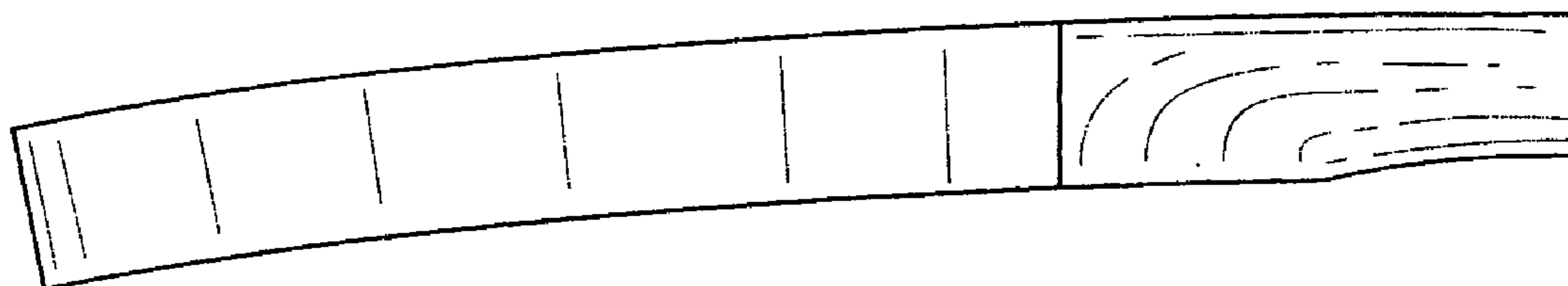

FIG. 5

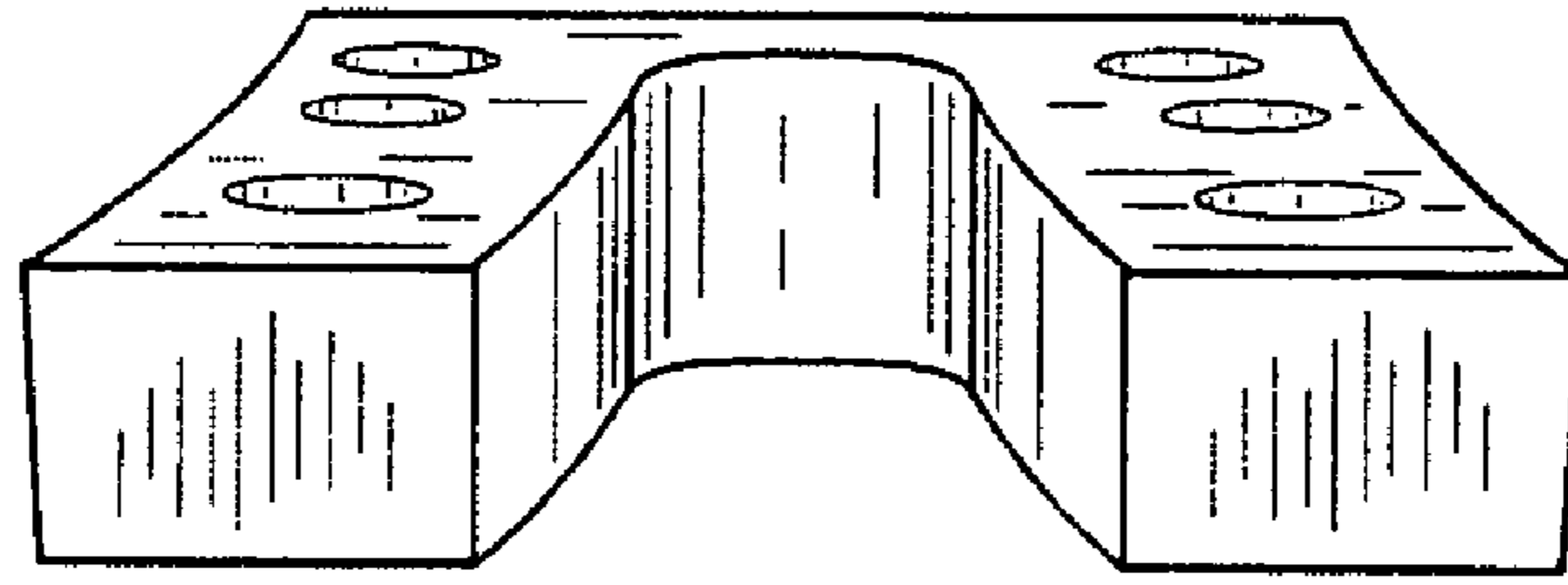

FIG. 6

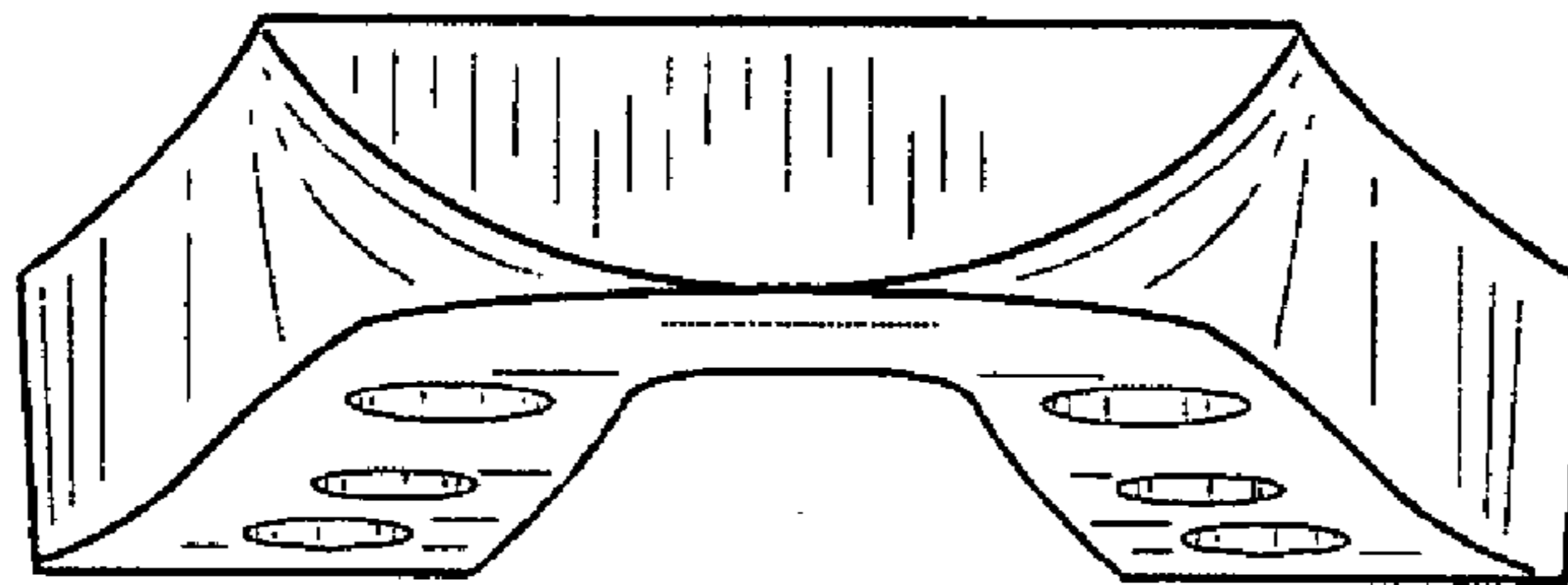

FIG. 7