



US00D560590S

(12) **United States Design Patent**
Cares

(10) **Patent No.:** **US D560,590 S**

(45) **Date of Patent:** **** Jan. 29, 2008**

(54) **EXTERIOR PORTION OF A BOAT SLIP CANOPY**

(75) Inventor: **Louis G. Cares**, East Grand Rapids, MI (US)

(73) Assignee: **P & L Company**, Kentwood, MI (US)

(**) Term: **14 Years**

(21) Appl. No.: **29/225,329**

(22) Filed: **Mar. 15, 2005**

(51) **LOC (8) Cl.** **12-06**

(52) **U.S. Cl.** **D12/317**

(58) **Field of Classification Search** D12/300,
D12/302, 308, 315–318; D25/25, 33, 34;
114/361

See application file for complete search history.

(56) **References Cited**

U.S. PATENT DOCUMENTS

3,312,990	A *	4/1967	Lapworth	114/361
3,600,866	A *	8/1971	Griffith	52/64
4,133,148	A *	1/1979	Swenumson	52/64
D256,113	S *	7/1980	Fortier	D12/318
4,300,253	A *	11/1981	Anderson	114/361
D284,361	S *	6/1986	Post	D12/11
4,894,961	A *	1/1990	Robbins	52/69
D307,129	S *	4/1990	Caouette	D12/315
4,984,399	A *	1/1991	Taylor	52/64
D332,935	S *	2/1993	Moore	D12/317
D334,837	S *	4/1993	Bradley	D12/402
D349,163	S *	7/1994	Rasmussen	D25/33
D356,773	S *	3/1995	Lange	D12/300
D367,638	S *	3/1996	Duncan	D12/300
D379,961	S *	6/1997	Cripe	D12/317
5,660,137	A *	8/1997	Manley	114/361
D402,373	S *	12/1998	James	D25/16
D421,131	S *	2/2000	Lynch	D25/34
D431,868	S *	10/2000	Hing	D25/23
6,129,034	A *	10/2000	Santa Cruz et al.	114/361
D455,994	S *	4/2002	Syfritt	D12/300

* cited by examiner

Primary Examiner—Holly H. Baynham

Assistant Examiner—Cynthia M. Chin

(74) *Attorney, Agent, or Firm*—Reising, Ethington, Barnes, Kisselle, P.C.

(57) **CLAIM**

The ornamental design for an exterior portion of a boat slip canopy, as shown and described.

DESCRIPTION

FIG. 1 is a right front perspective view of a first embodiment of an exterior portion of a boat slip canopy showing my new design with the rear access hatch closed, the left front perspective view being a mirror image thereof.

FIG. 2 is a right rear perspective view of the canopy of FIG. 1, the left rear perspective view being a mirror image thereof.

FIG. 3 is a rear perspective view as in FIG. 2, but showing the rear access hatch open.

FIG. 4 is a right side view of the canopy of FIG. 1 with the rear access hatch closed, the left side view being a mirror image thereof.

FIG. 5 is a right side view as in FIG. 4, but with the rear access hatch open, the left side view being a mirror image thereof.

FIG. 6 is a top view of the canopy of FIG. 1.

FIG. 7 is a front view of the canopy of FIG. 1.

FIG. 8 is a rear view of the canopy of FIG. 1.

FIG. 9 is a right front perspective view of a second embodiment of an exterior portion of a boat slip canopy showing my new design.

FIG. 10 is a right side view of the canopy of FIG. 9, the left side view being a mirror image thereof.

FIG. 11 is a front view of the canopy of FIG. 9; and,

FIG. 12 is a rear view of the canopy of FIG. 9.

The broken lines shown in FIGS. 1–5, 9 and 10 are for illustrative purposes only and form no part of the claimed design.

1 Claim, 4 Drawing Sheets

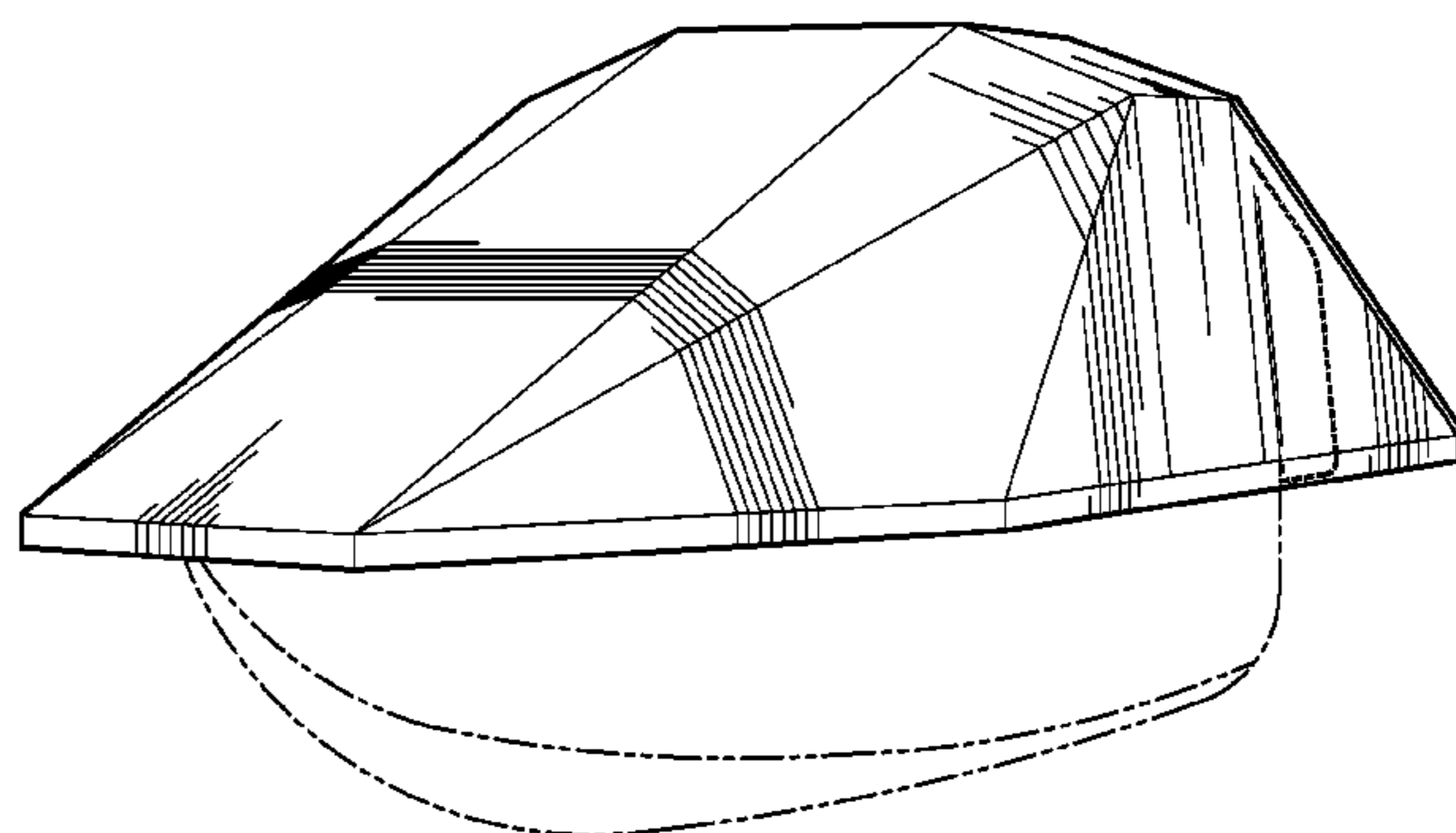
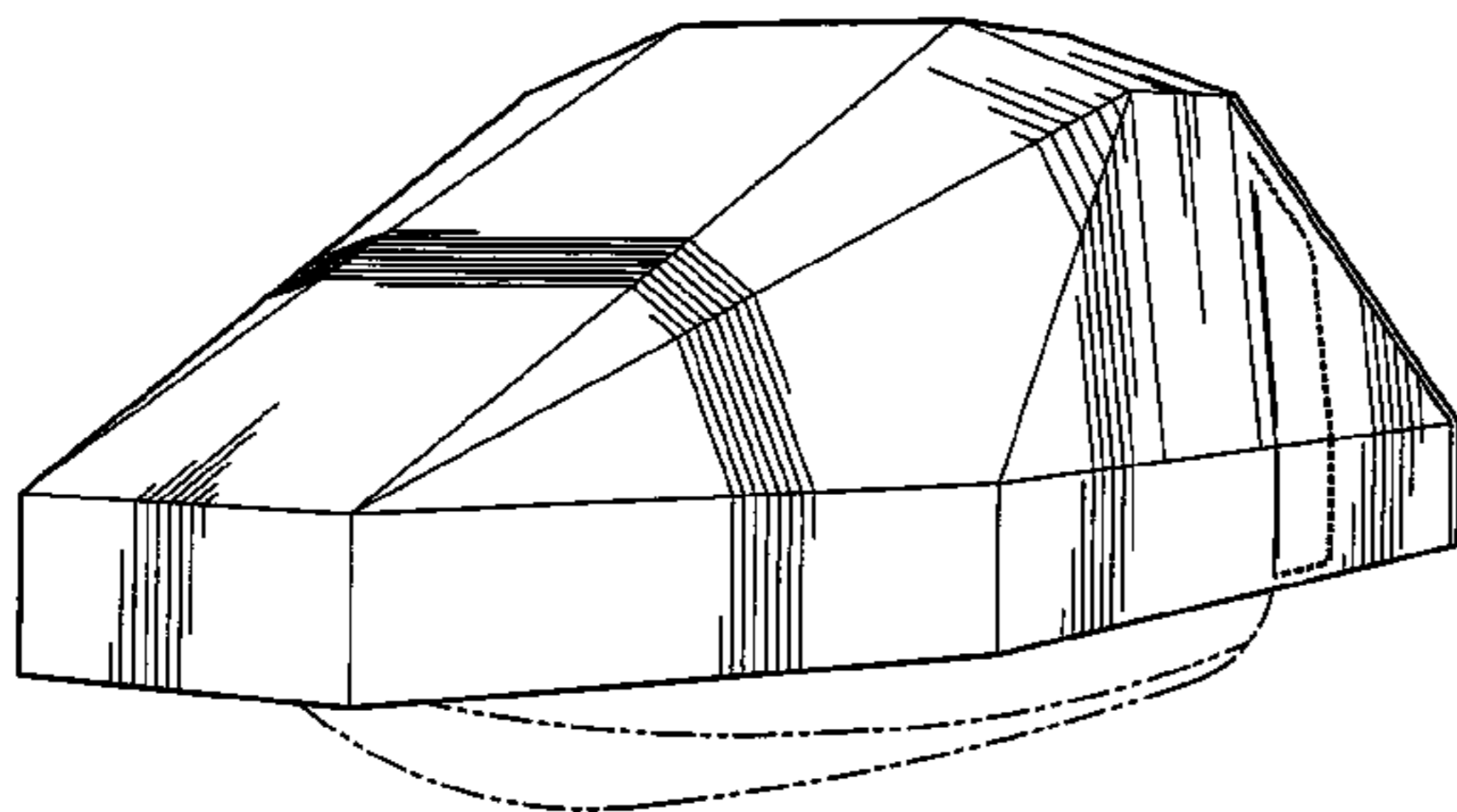

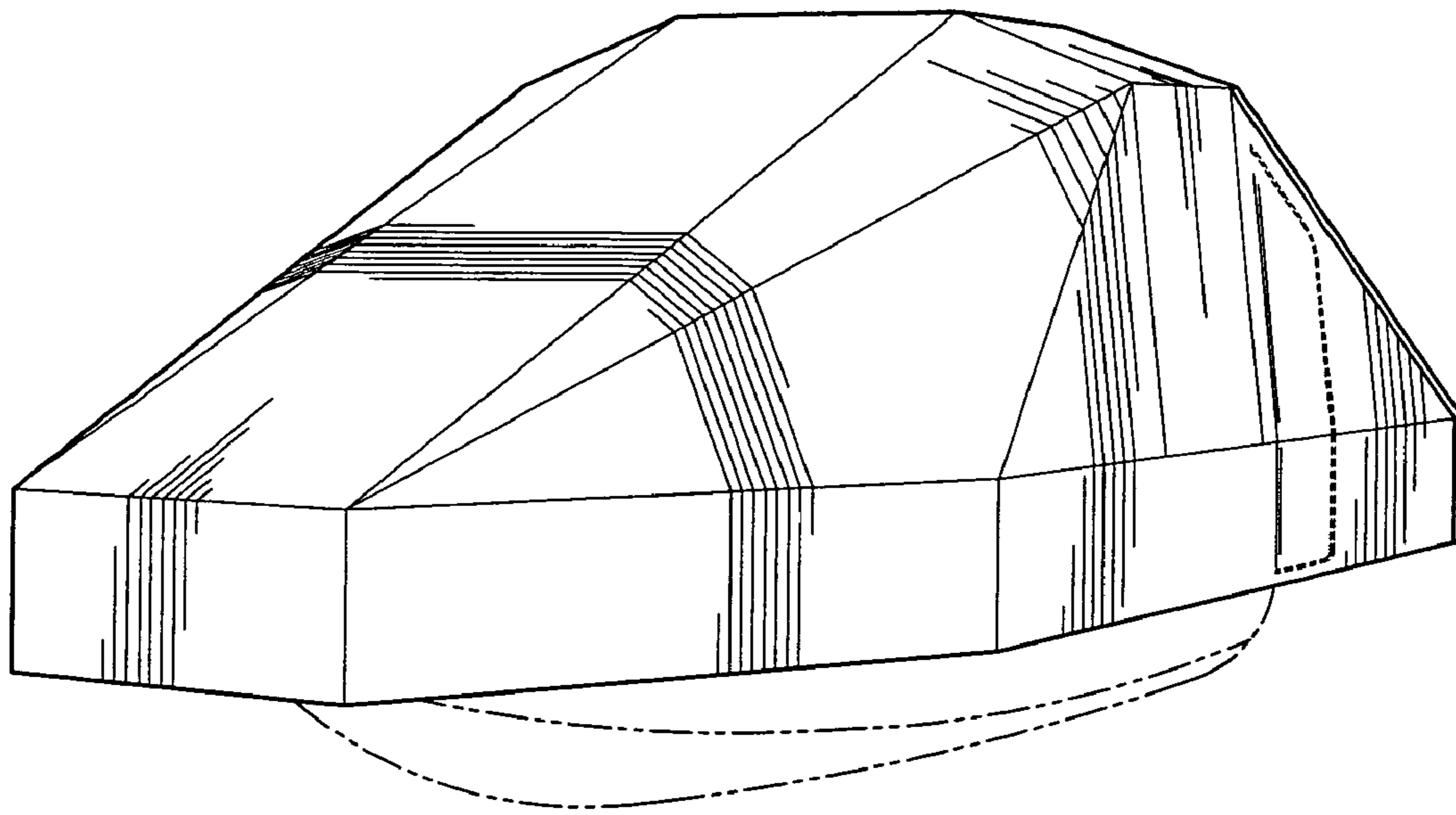

Figure 1

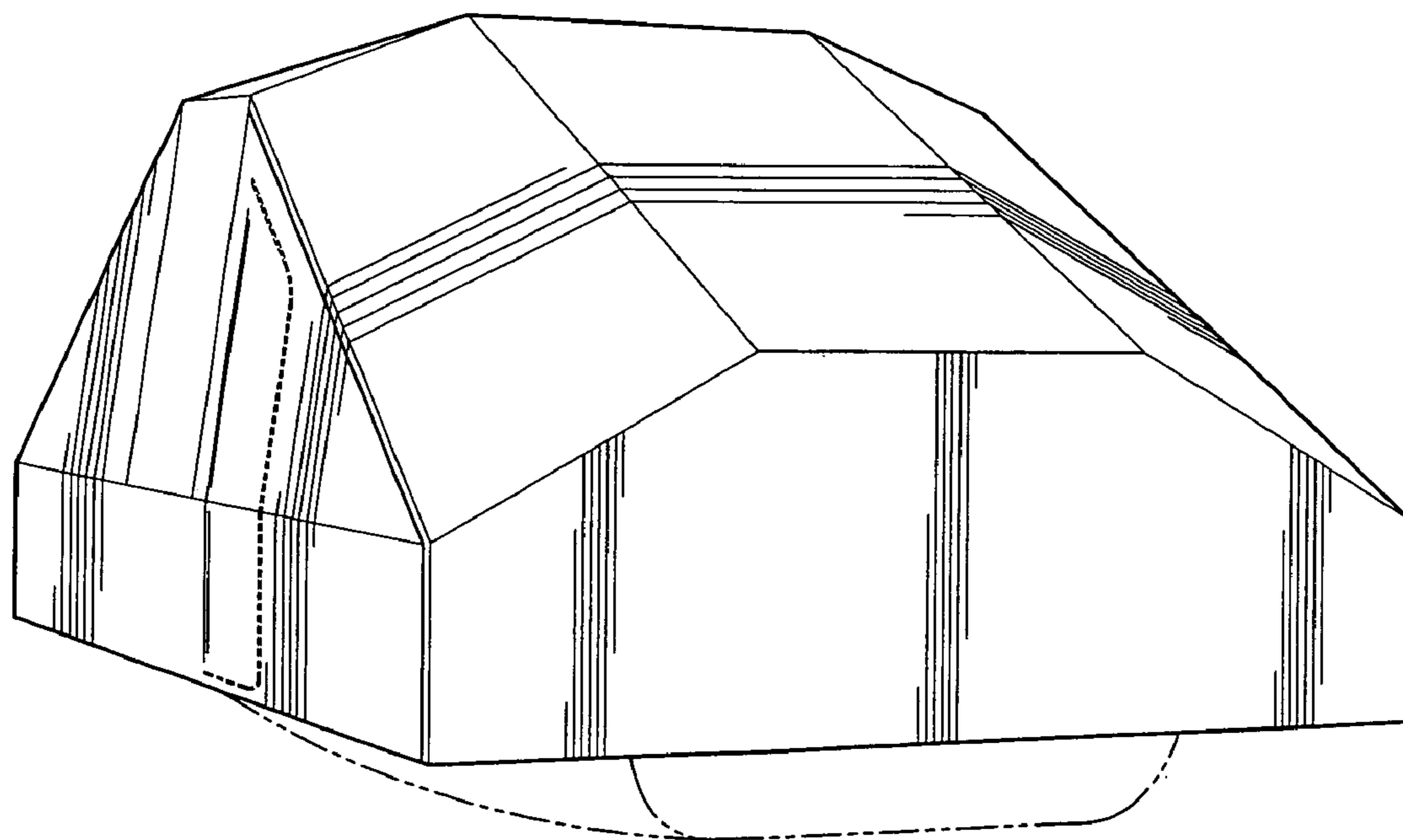

Figure 2

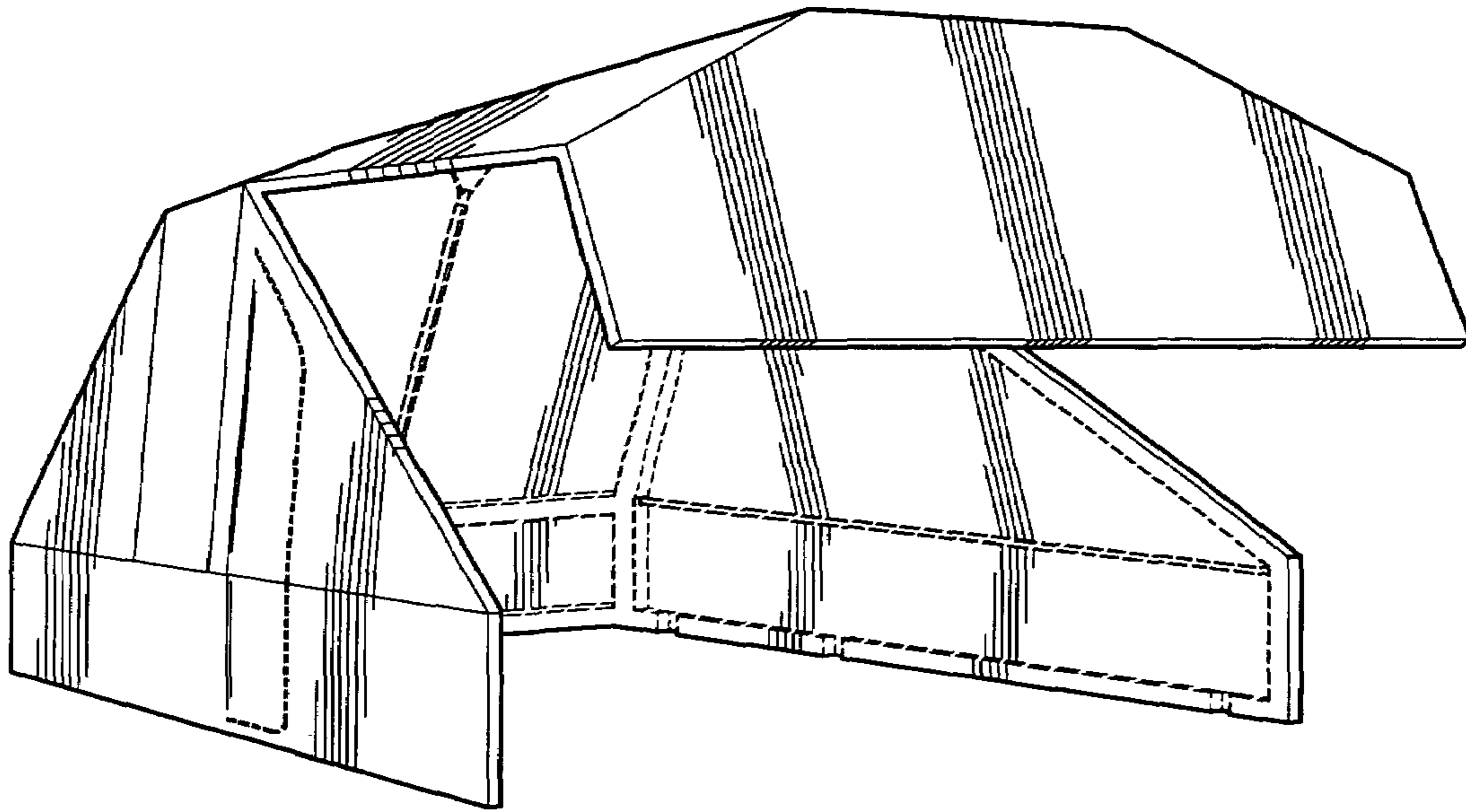

Figure 3

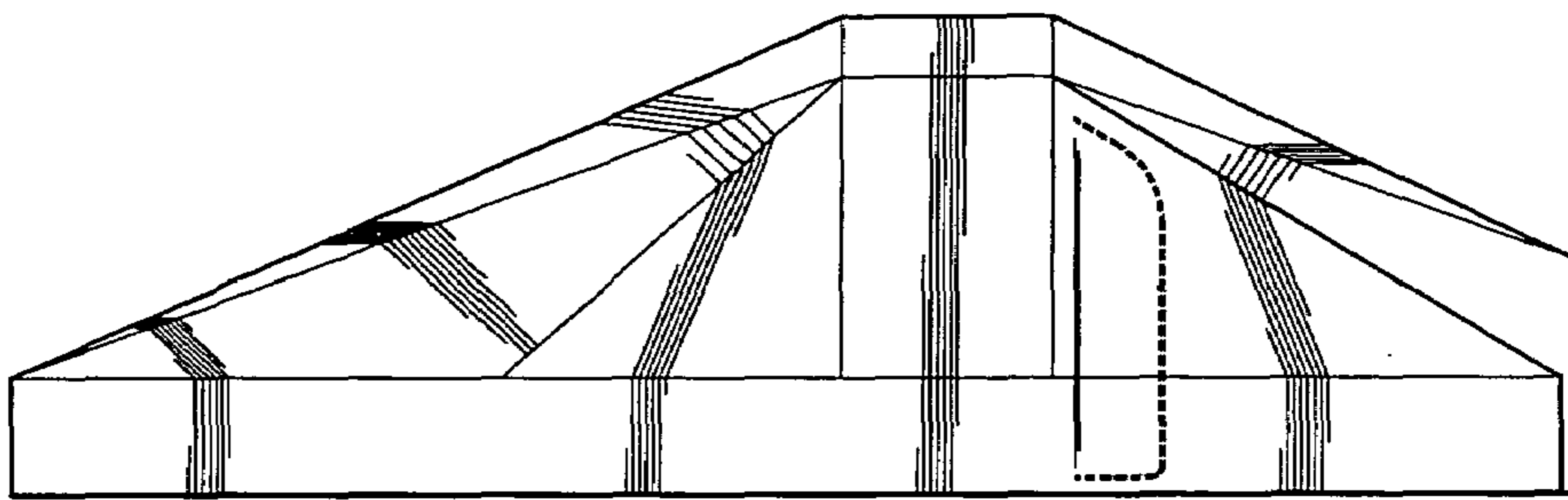

Figure 4

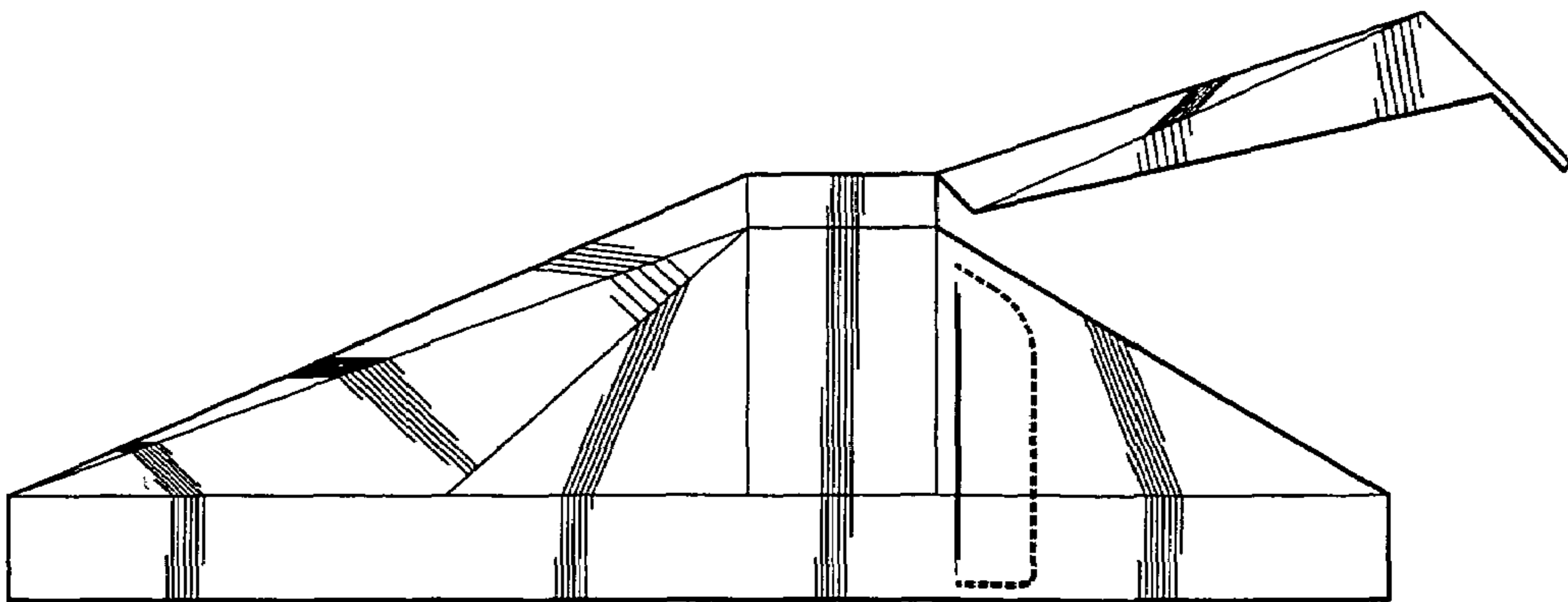

Figure 5

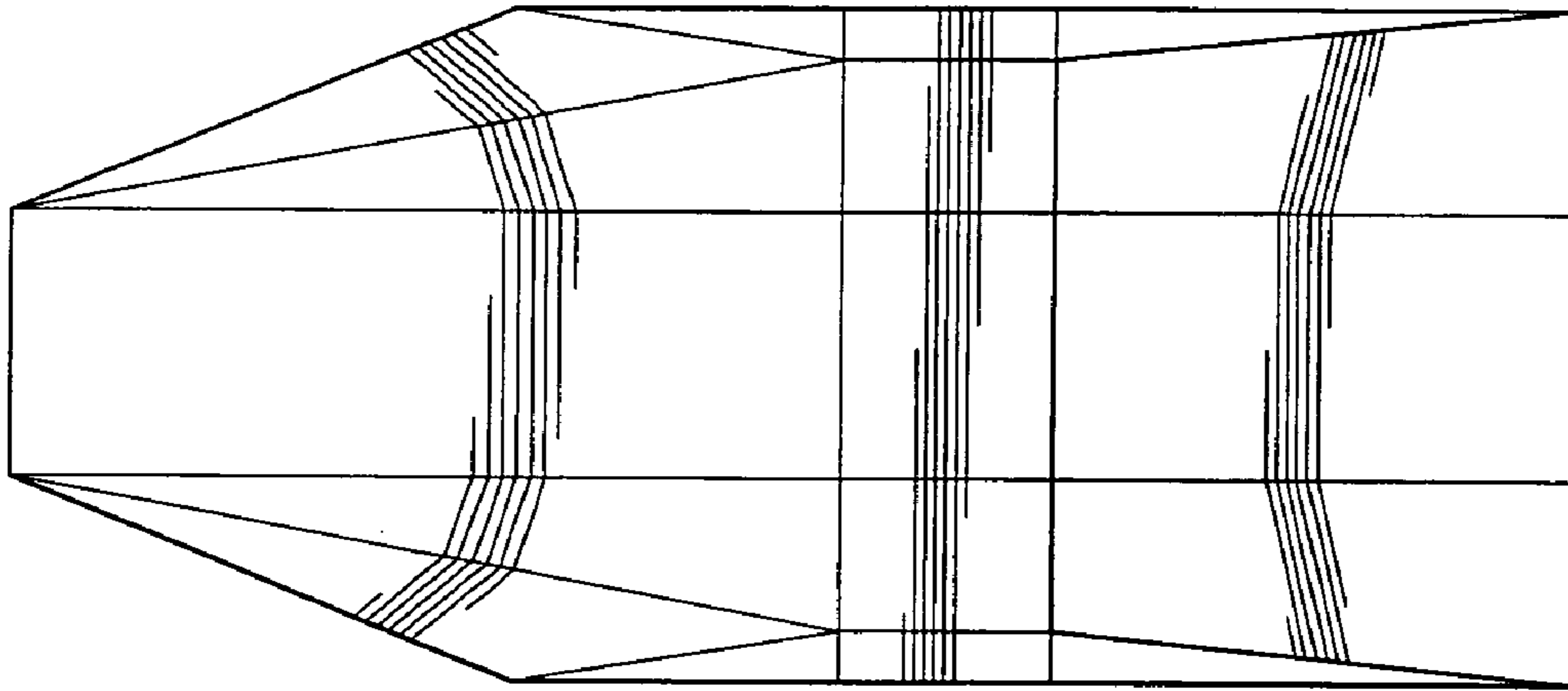

Figure 6

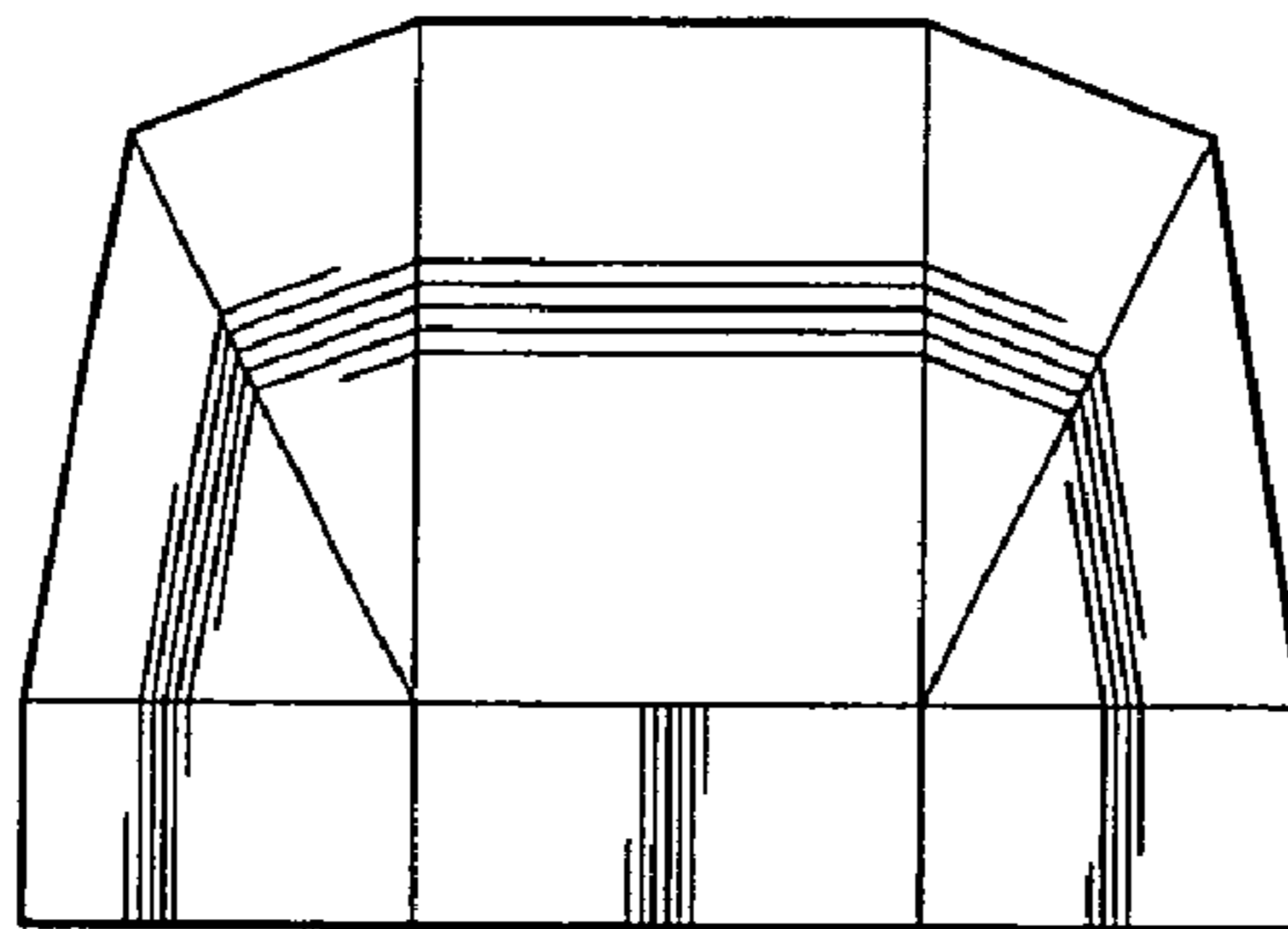

Figure 7

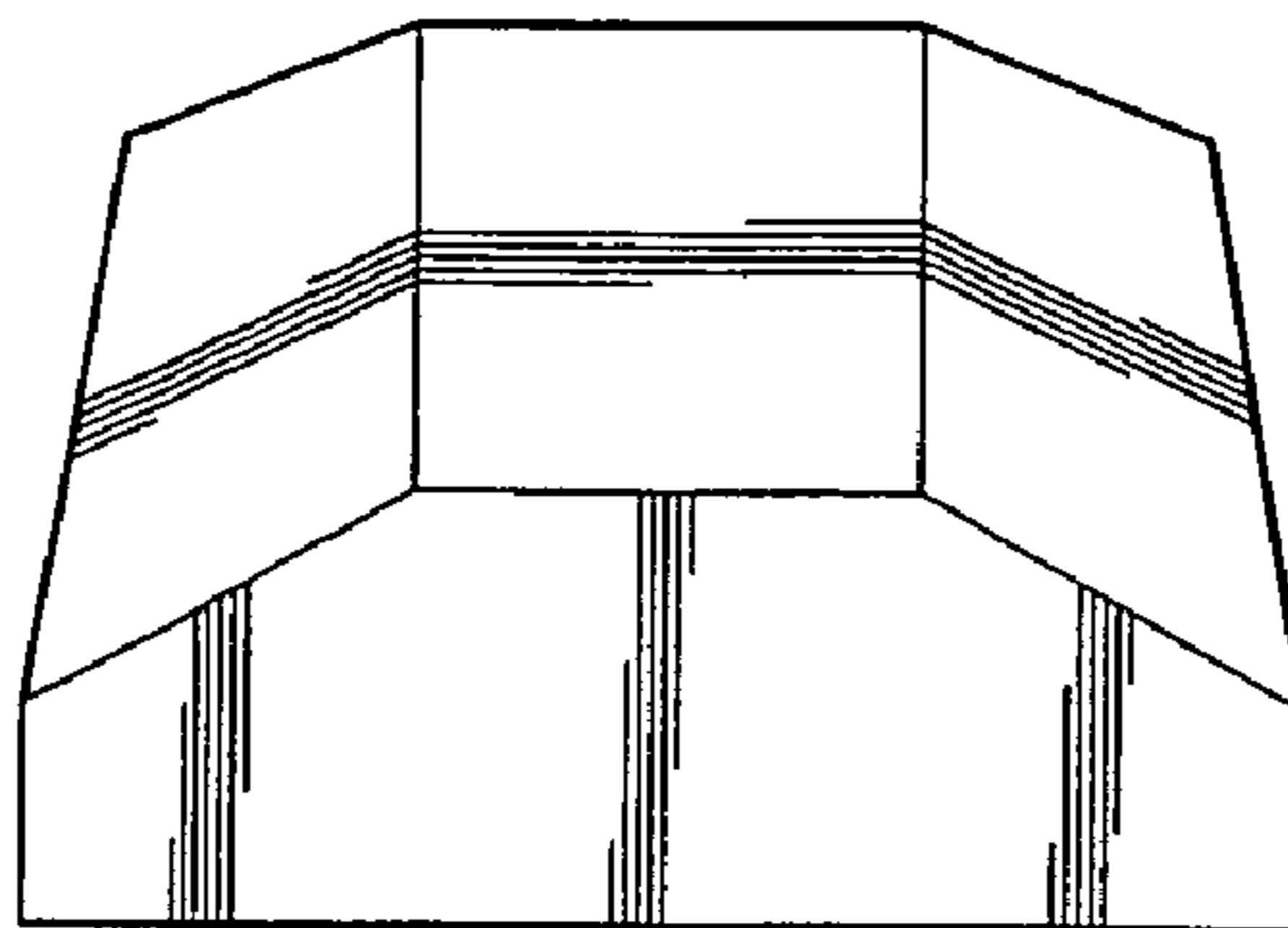

Figure 8

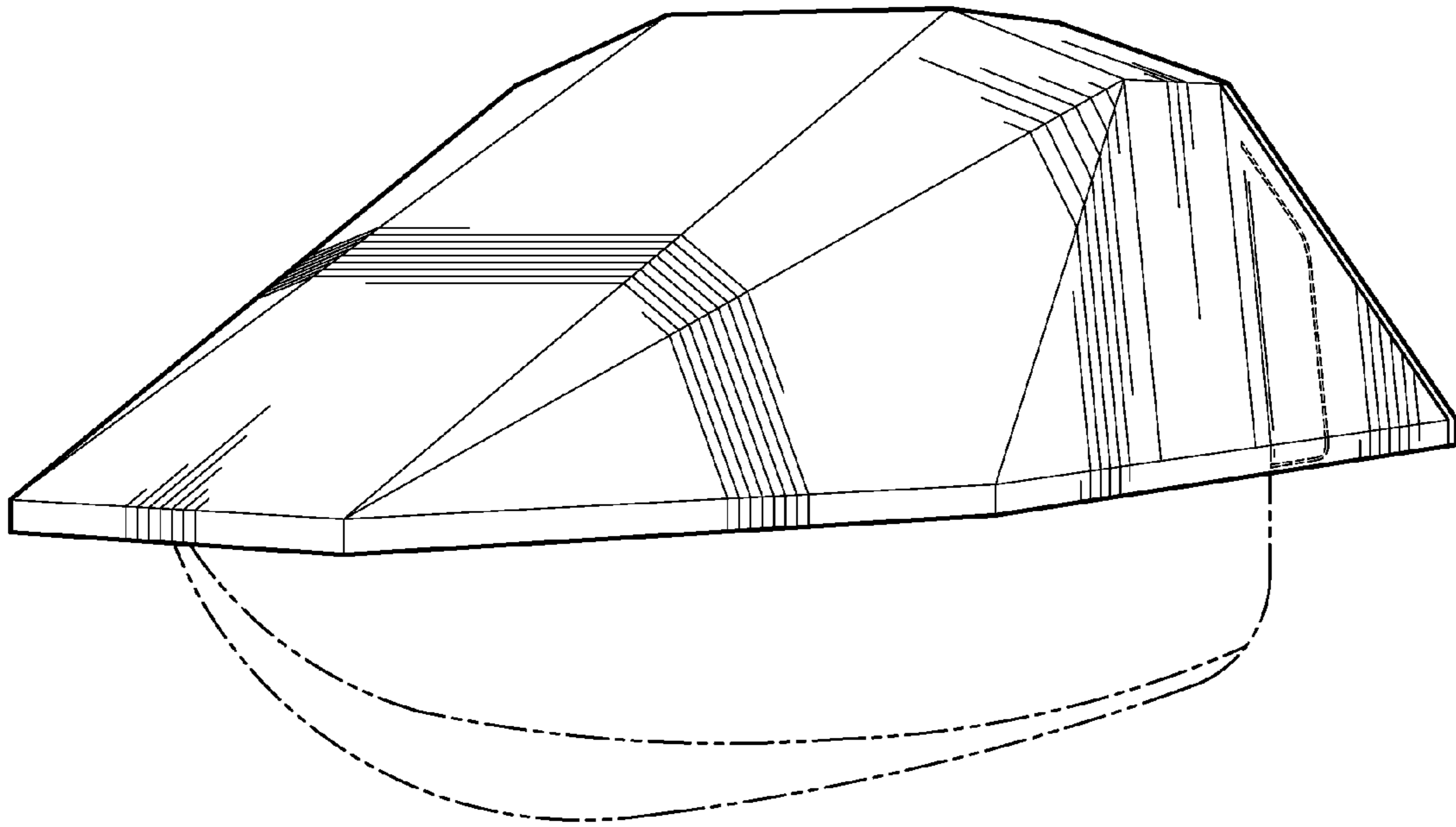

Figure 9

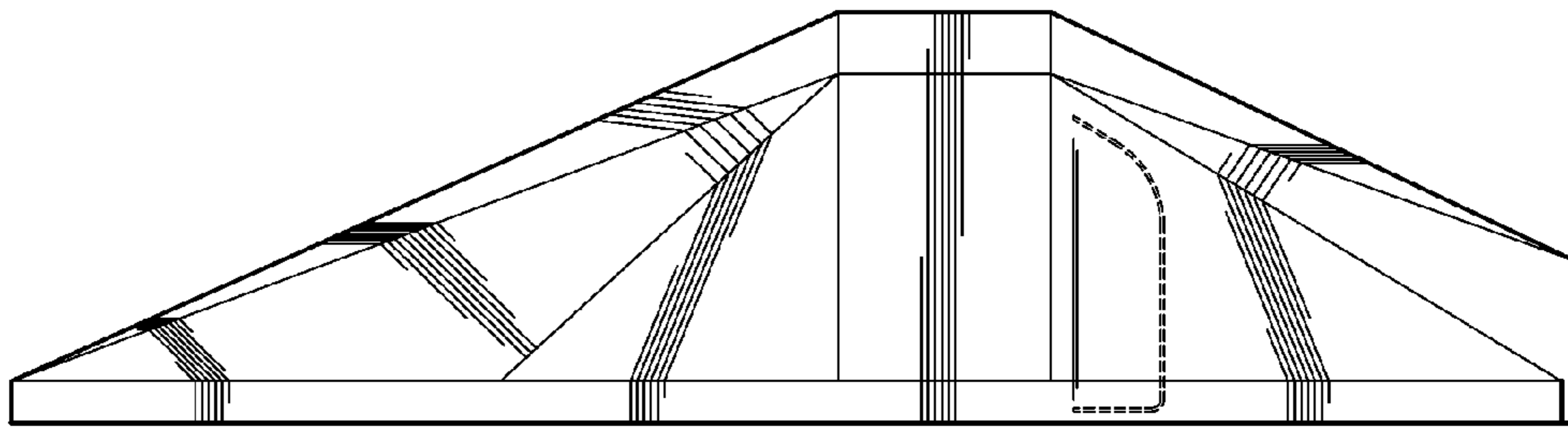

Figure 10

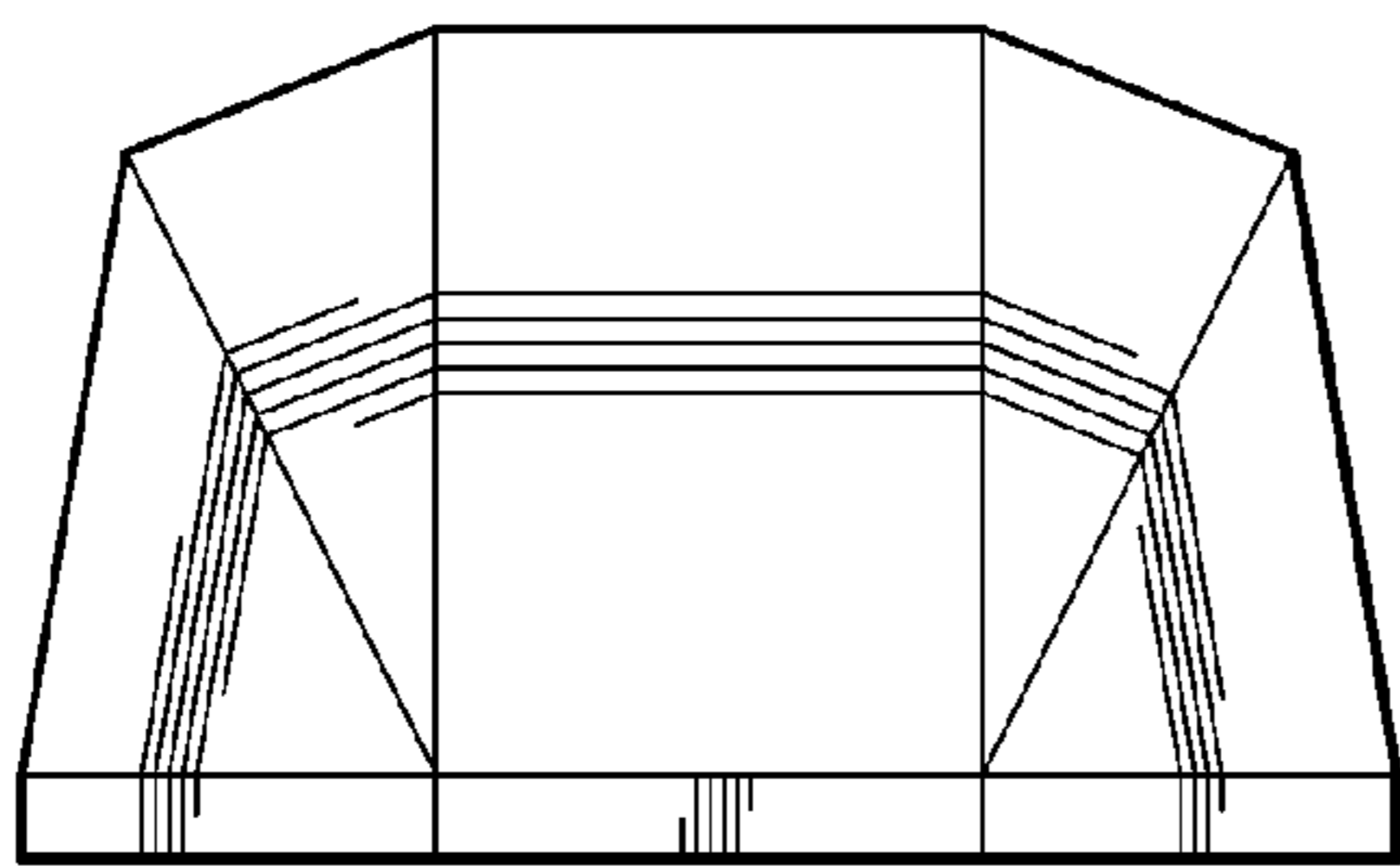

Figure 11

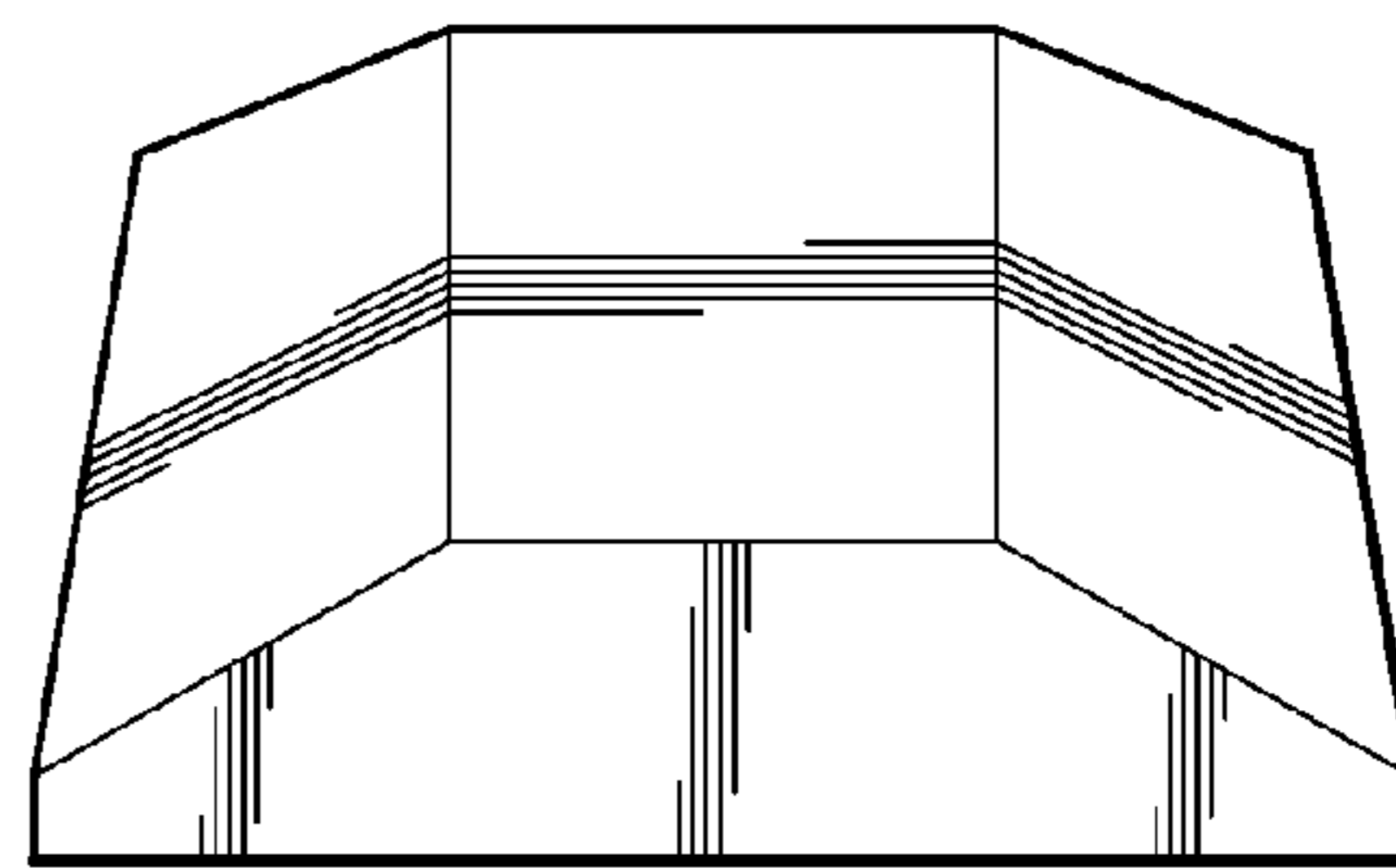

Figure 12