



US00D560583S

(12) **United States Design Patent** (10) **Patent No.:** **US D560,583 S**  
**Simons et al.** (45) **Date of Patent:** **\*\* Jan. 29, 2008**

(54) **FENDER PANEL FOR TRUCK HOOD**  
 (75) Inventors: **Wayne K Simons**, Kent, WA (US); **F Erik Tuft**, Kenmore, WA (US); **Steven H Hovind**, Bellevue, WA (US); **Gerald Jay Angelo**, Bellevue, WA (US); **Wallace A Peltola**, Sammamish, WA (US); **Daniel R Kieffer**, Kirkland, WA (US)

(73) Assignee: **PACCAR Inc**, Bellevue, WA (US)

(\*\*) Term: **14 Years**

(21) Appl. No.: **29/238,201**

(22) Filed: **Sep. 12, 2005**

(51) **LOC (8) Cl.** ..... **12-16**  
 (52) **U.S. Cl.** ..... **D12/196**  
 (58) **Field of Classification Search** ..... D12/196,  
 D12/190, 90-92, 96; 296/56, 57.1, 184.1,  
 296/185.1, 186.1

See application file for complete search history.

(56) **References Cited**

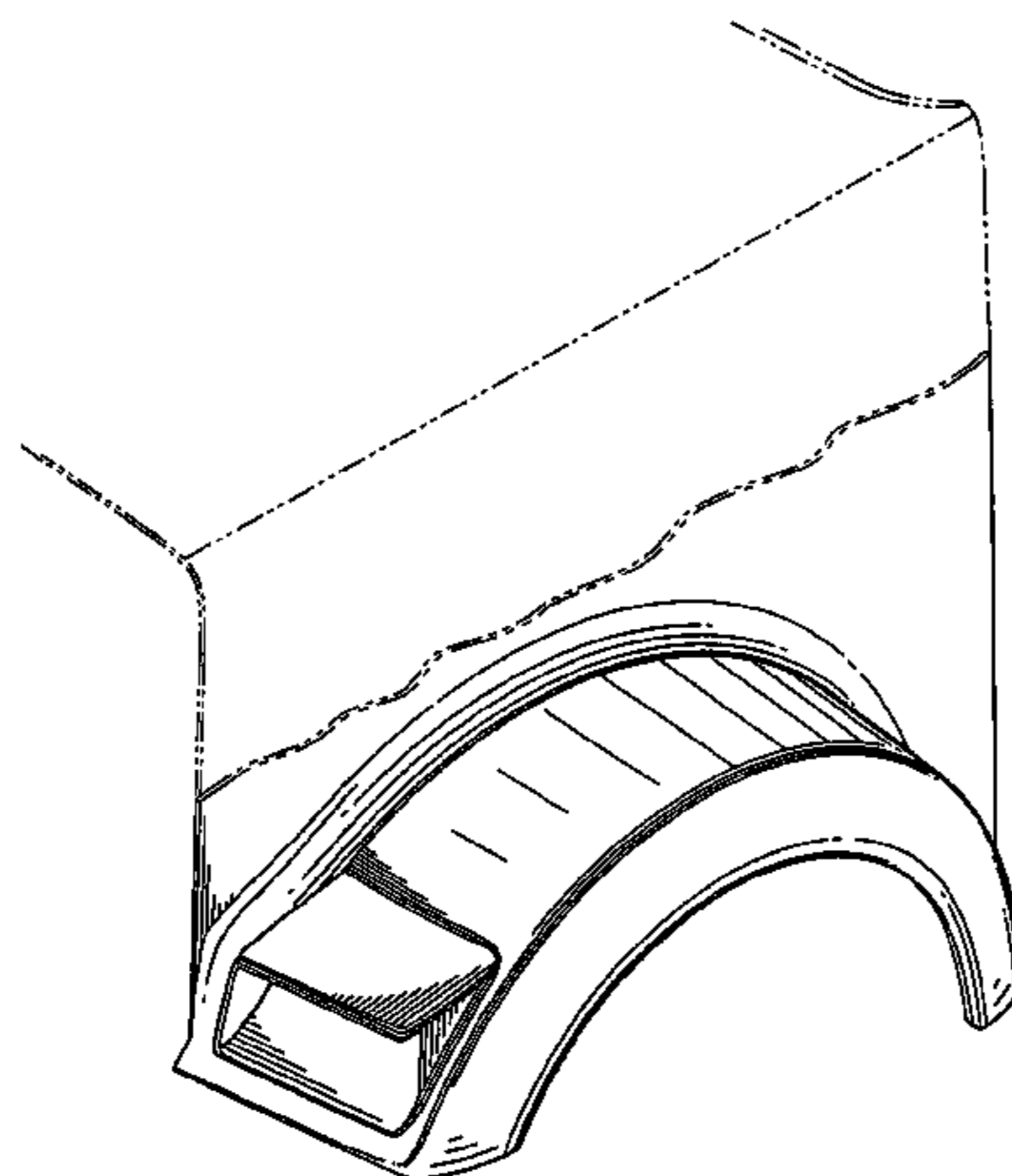
U.S. PATENT DOCUMENTS

D291,872 S 9/1987 Simons et al.  
 D291,982 S 9/1987 Simons et al.  
 D307,731 S 5/1990 Kerney et al.  
 D308,032 S 5/1990 Kerney et al.  
 D312,805 S 12/1990 Marlowe et al.  
 D313,966 S 1/1991 Marlowe et al.  
 D320,583 S 10/1991 Simons et al.  
 D329,214 S 9/1992 Marlowe et al.  
 D366,638 S 1/1996 Tucker et al.  
 D366,640 S 1/1996 Tucker et al.  
 D382,841 S 8/1997 Norwood et al.  
 D382,844 S 8/1997 Norwood et al.  
 D384,019 S 9/1997 Meryman et al.  
 D395,860 S 7/1998 Meryman et al.  
 D403,636 S 1/1999 Meryman et al.  
 D411,140 S 6/1999 Meryman et al.  
 D411,494 S 6/1999 Meryman et al.  
 D412,689 S 8/1999 Onopa

D422,251 S 4/2000 Bader et al.  
 D423,990 S 5/2000 Meryman et al.  
 D424,489 S 5/2000 Damon et al.  
 D425,450 S 5/2000 Barraclough et al.  
 D431,806 S 10/2000 Damon et al.  
 D433,980 S 11/2000 Conway et al.  
 D433,981 S 11/2000 Davis et al.  
 D434,347 S 11/2000 Damon et al.  
 D434,358 S 11/2000 Conway et al.  
 D435,816 S 1/2001 Delashaw et al.  
 D436,563 S 1/2001 Delashaw et al.  
 D436,894 S 1/2001 Barraclough et al.  
 D437,258 S 2/2001 Meryman et al.  
 D437,570 S 2/2001 Meryman et al.  
 D446,175 S 8/2001 Hoyle, Jr.  
 D460,023 S \* 7/2002 Beigel ..... D12/96  
 D465,749 S \* 11/2002 Beigel ..... D12/96  
 D466,450 S \* 12/2002 Maher et al. .... D12/96  
 D475,657 S 6/2003 Wong et al.  
 D478,300 S 8/2003 Chiang  
 D482,993 S 12/2003 Conway et al.  
 D484,077 S 12/2003 Conway et al.  
 D488,112 S 4/2004 Satou  
 D490,749 S 6/2004 Satou et al.  
 D492,921 S 7/2004 Perfetti et al.  
 D494,900 S 8/2004 Satou  
 D496,620 S \* 9/2004 Perfetti et al. .... D12/196  
 D497,581 S 10/2004 Conway et al.  
 D499,679 S \* 12/2004 Perfetti et al. .... D12/196  
 D502,904 S 3/2005 Delashaw et al.  
 D504,642 S 5/2005 Perfetti  
 D514,483 S 2/2006 Chiang  
 D518,761 S 4/2006 Chiang  
 D522,426 S \* 6/2006 Beigel et al. .... D12/196  
 D522,945 S \* 6/2006 Beigel et al. .... D12/196

OTHER PUBLICATIONS

Kenworth Truck Company W900 brochure, Kirkland, Wash, 2005.  
 Kenworth Truck Company W900 brochure, Kirkland, Wash, 2002.  
 Kenworth Truck Company W900 brochure, Kirkland, Wash, 1996.  
 Kenworth Truck Company T2000 brochure, Kirkland, Wash, 2005.  
 Kenworth Truck Company T2000 brochure, Kirkland, Wash, 2002.  
 Kenworth Truck Company T800 brochure, Kirkland, Wash, 2005.  
 Kenworth Truck Company T800 brochure, Kirkland, Wash, 2003.  
 Kenworth Truck Company T800 brochure, Kirkland, Wash, 2002.  
 Kenworth Truck Company T600 brochure, Kirkland, Wash, 2005.  
 Kenworth Truck Company T600 brochure, Kirkland, Wash, 2002.  
 Kenworth Truck Company T600 brochure, Kirkland, Wash, 1996.



Kenworth Truck Company T300 brochure, Kirkland, Wash, 2005.  
Kenworth Truck Company T300 brochure, Kirkland, Wash, 2001.

\* cited by examiner

*Primary Examiner*—Melody N. Brown  
*(74) Attorney, Agent, or Firm*—Christensen O'Connor  
Johnson Kindness PLLC

(57) **CLAIM**

The ornamental design for a fender panel for truck hood, as shown and described.

**DESCRIPTION**

FIG. 1 is a front perspective view of a fender panel for truck hood showing a first embodiment of our new design;

FIG. 2 is a front elevational view of the fender panel for truck hood of FIG. 1;

FIG. 3 is a rear elevational view of the fender panel for truck hood of FIG. 1;

FIG. 4 is a top plan view of the fender panel for truck hood of FIG. 1;

FIG. 5 is a bottom plan view of the fender panel for truck hood of FIG. 1;

FIG. 6 is a right side elevational view of the fender panel for truck hood of FIG. 1, the left side elevational view of the fender panel for truck hood of FIG. 1 is unornamented;

FIG. 7 is a front perspective view of a fender panel for truck hood showing a second embodiment of our new design;

FIG. 8 is a front elevational view of a fender panel for truck hood of FIG. 7;

FIG. 9 is a rear elevational view of the fender panel for truck hood of FIG. 7;

FIG. 10 is a top plan view of the fender panel for truck hood of FIG. 7;

FIG. 11 is a bottom plan view of the fender panel for truck hood of FIG. 7;

FIG. 12 is a left side elevational view of the fender panel for truck hood of FIG. 7, the right side elevational view of the fender panel for truck hood of FIG. 7 is unornamented;

FIG. 13 is a front perspective view of a fender panel for truck hood showing a third embodiment of our new design;

FIG. 14 is a front elevational view of the fender panel for truck hood of FIG. 13;

FIG. 15 is a rear elevational view of the fender panel for truck hood of FIG. 13;

FIG. 16 is a top plan view of the fender panel for truck hood of FIG. 13;

FIG. 17 is a bottom plan view of the fender panel for truck hood of FIG. 13;

FIG. 18 is a right side elevational view of the fender panel for truck hood of FIG. 13, the left side elevational view of the fender panel for truck hood of FIG. 13 is unornamented;

FIG. 19 is a front perspective view of a fender panel for truck hood showing a fourth embodiment of our new design;

FIG. 20 is a front elevational view of the fender panel for truck hood of FIG. 19;

FIG. 21 is a rear elevational view of the fender panel for truck hood of FIG. 19;

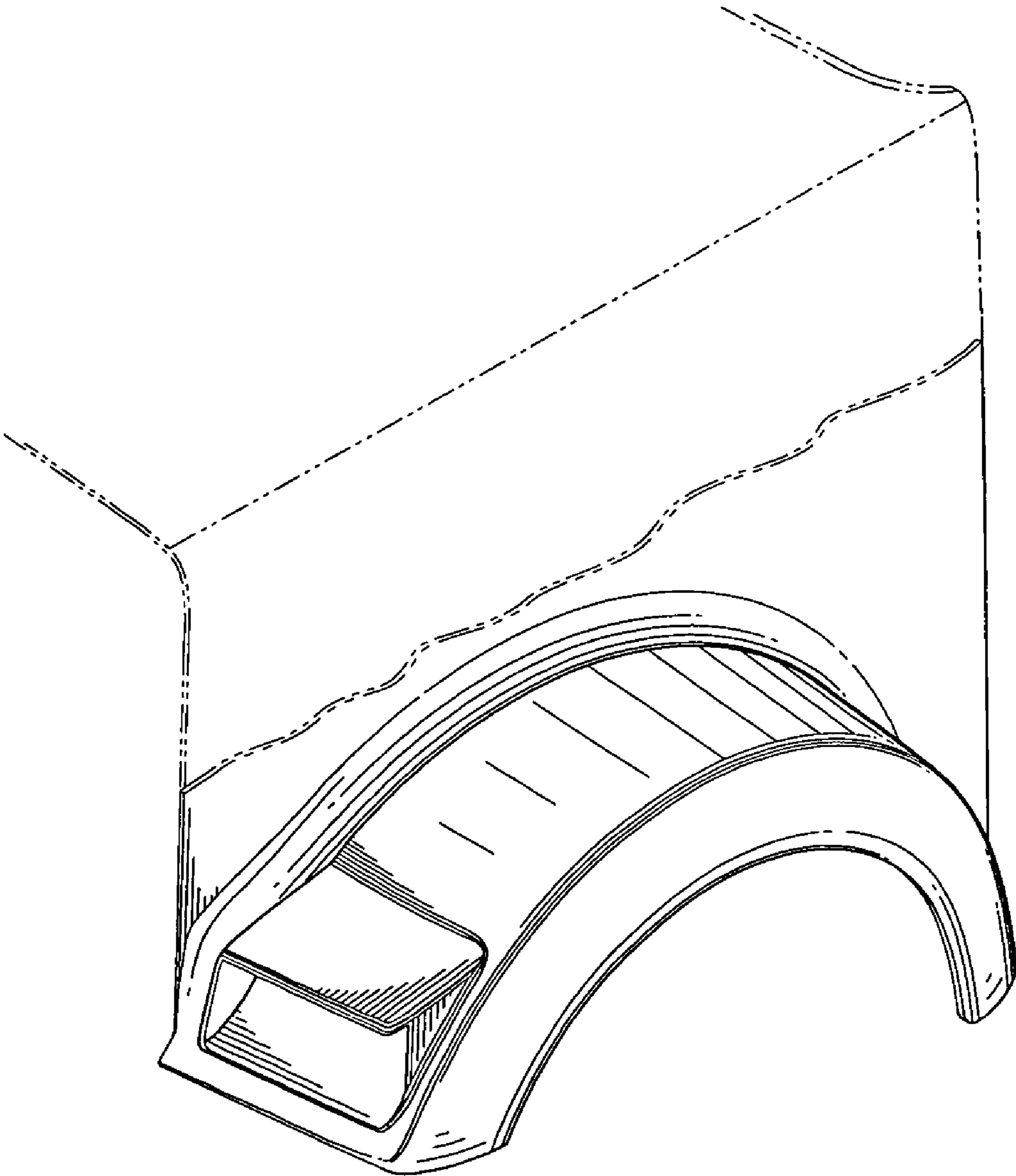
FIG. 22 is a top plan view of the fender panel for truck hood of FIG. 19;

FIG. 23 is a bottom plan view of the fender panel for truck hood of FIG. 19; and,

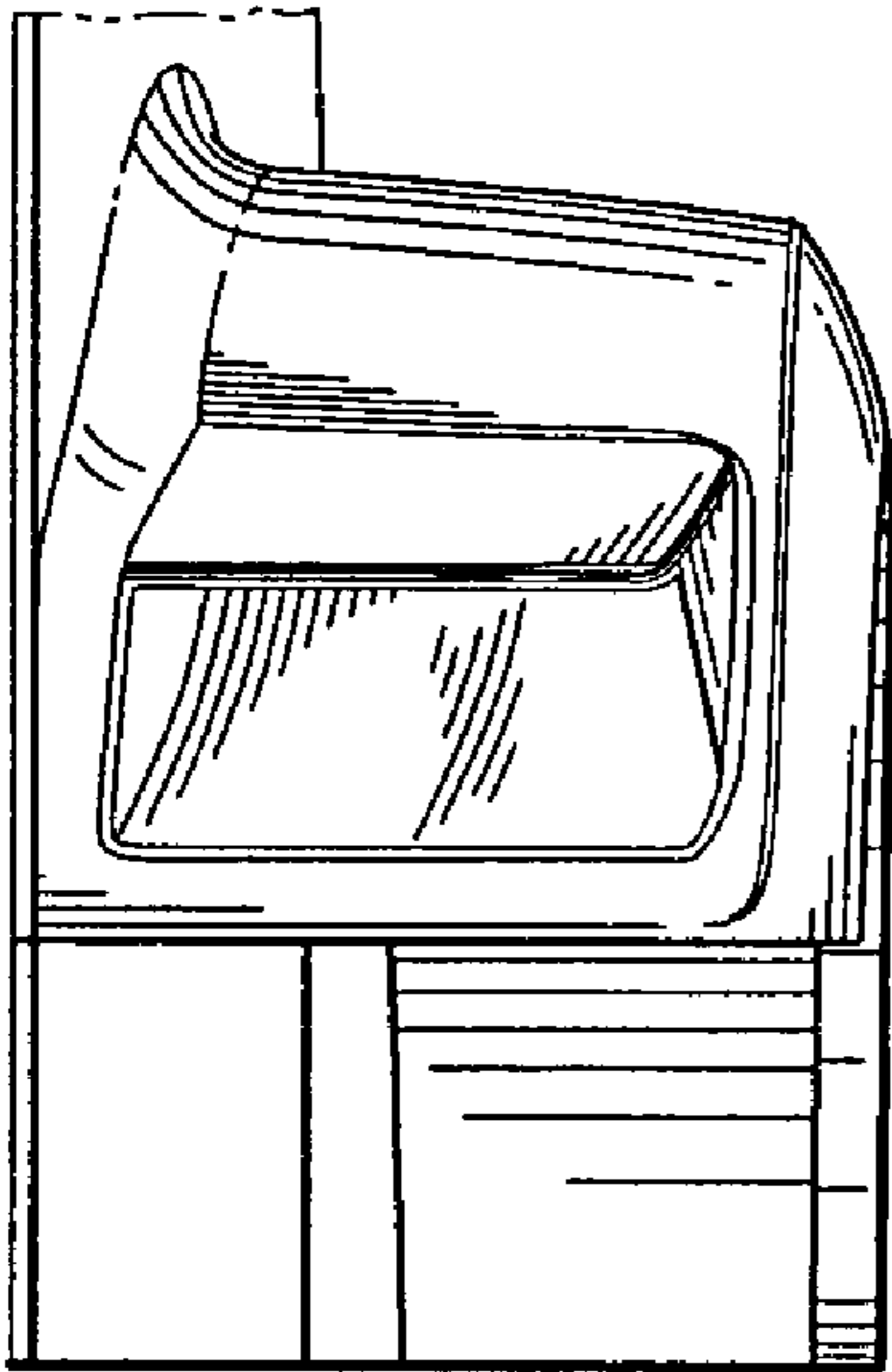
FIG. 24 is a left side elevational view of the fender panel for truck hood of FIG. 19, the right side elevational view of the fender panel for truck hood of FIG. 19 is unornamented.

The broken lines in the drawings form no part of the claimed design.

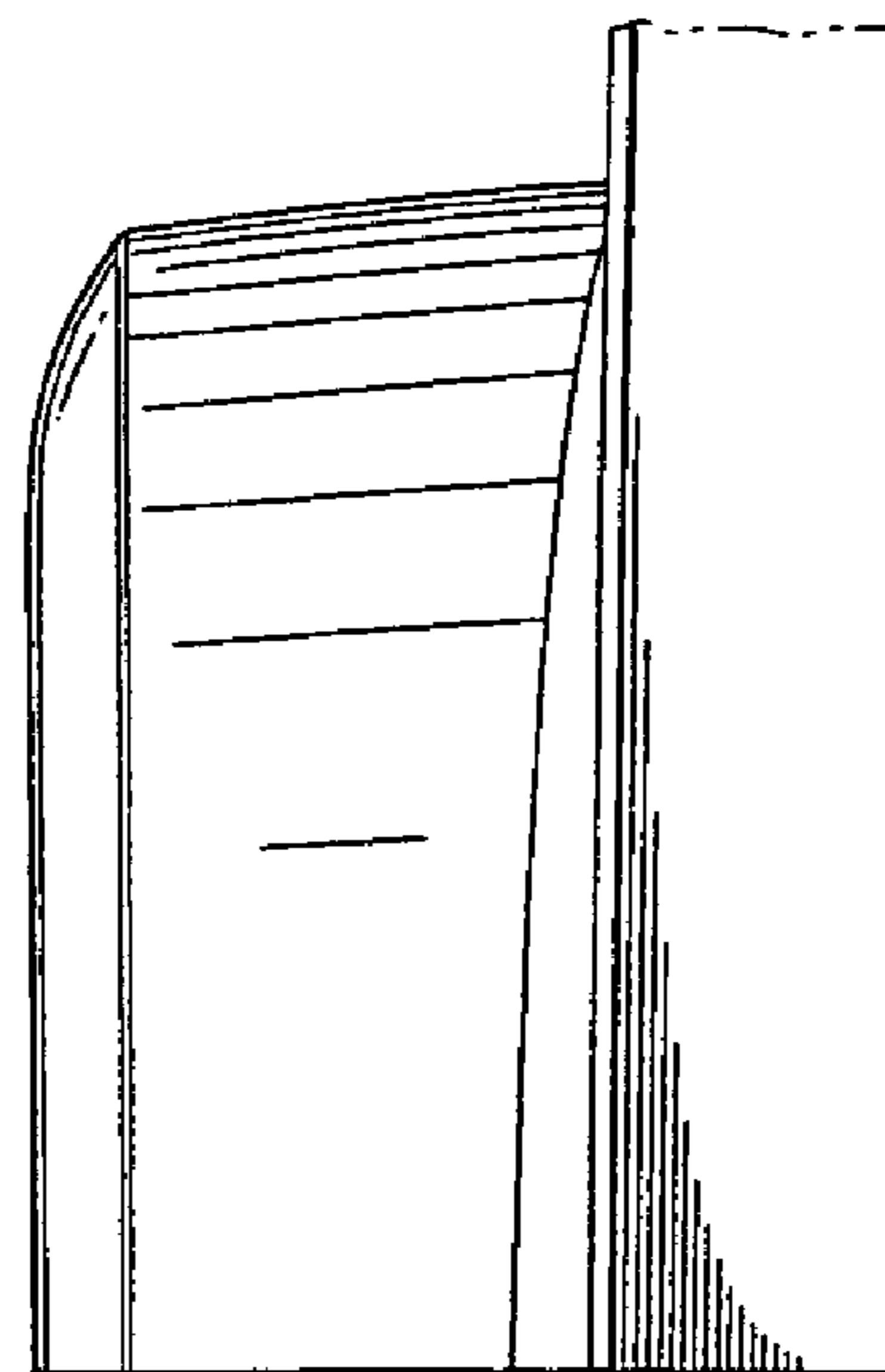
**1 Claim, 16 Drawing Sheets**



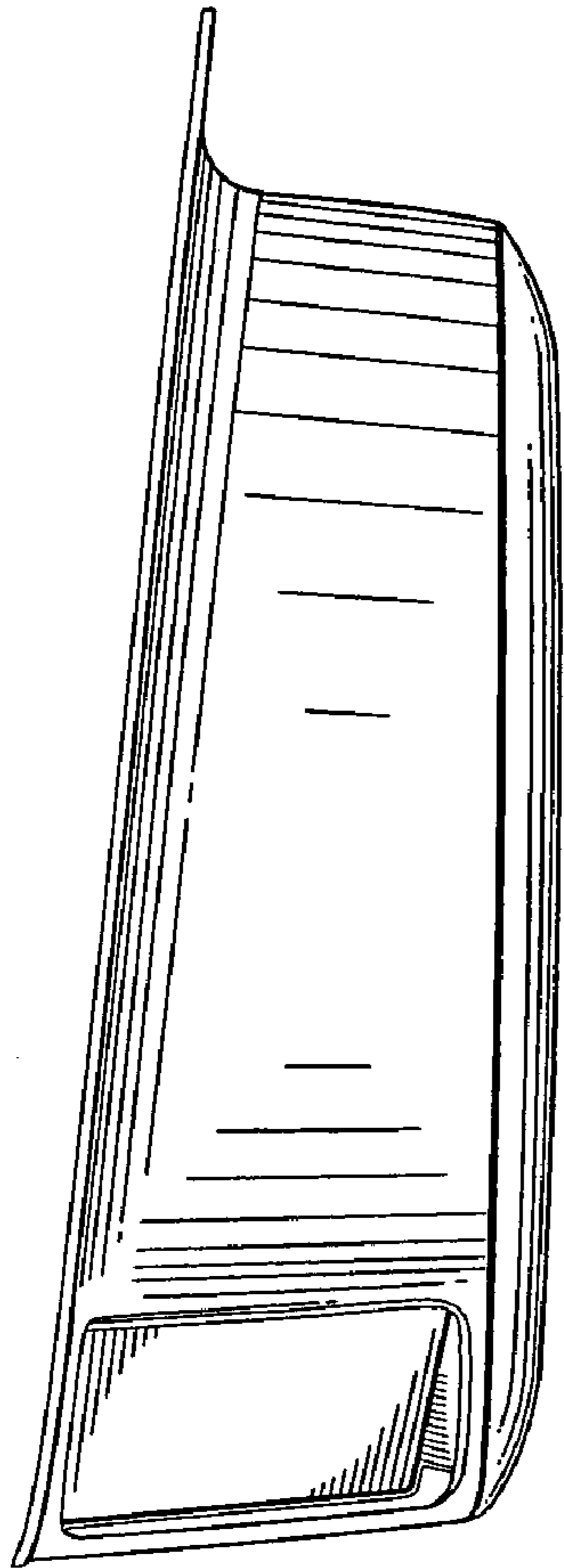
*Fig. 1.*



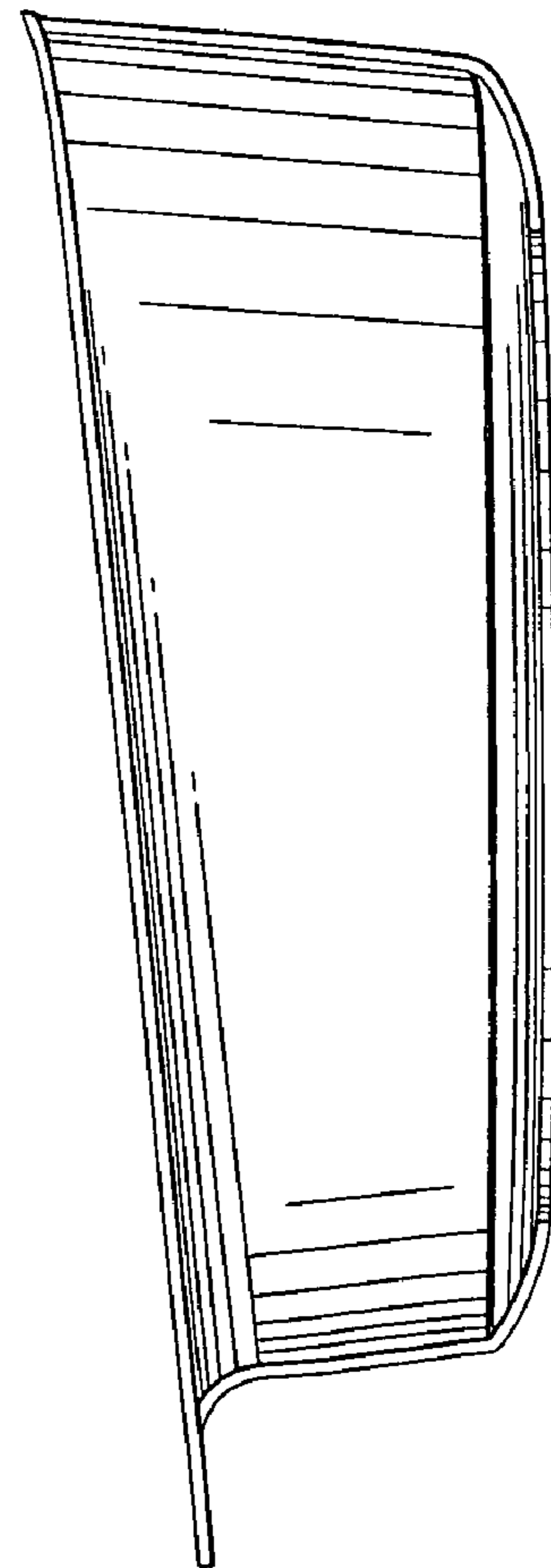
*Fig. 2.*



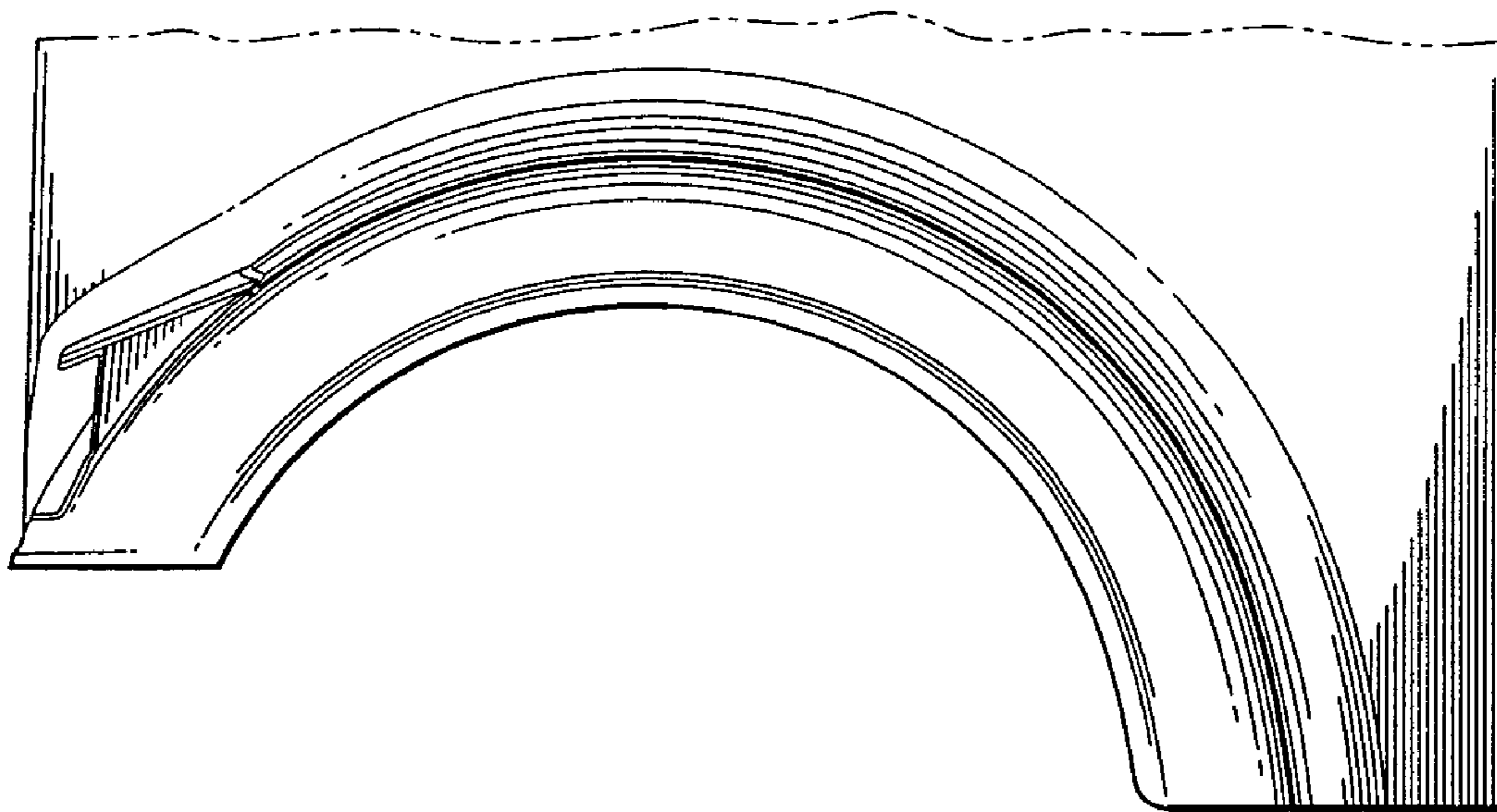
*Fig. 3.*



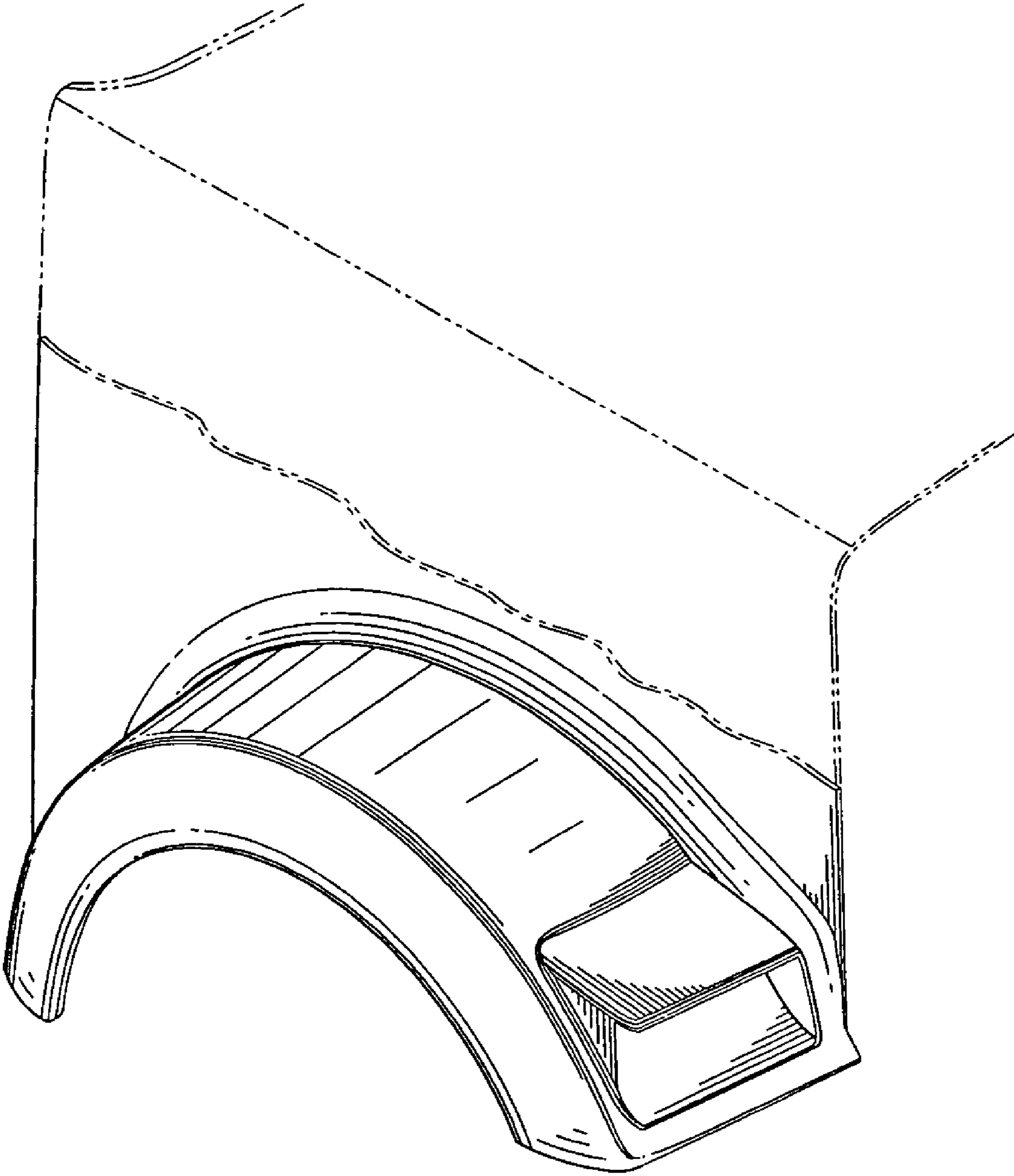
*Fig. 4.*



*Fig. 5.*

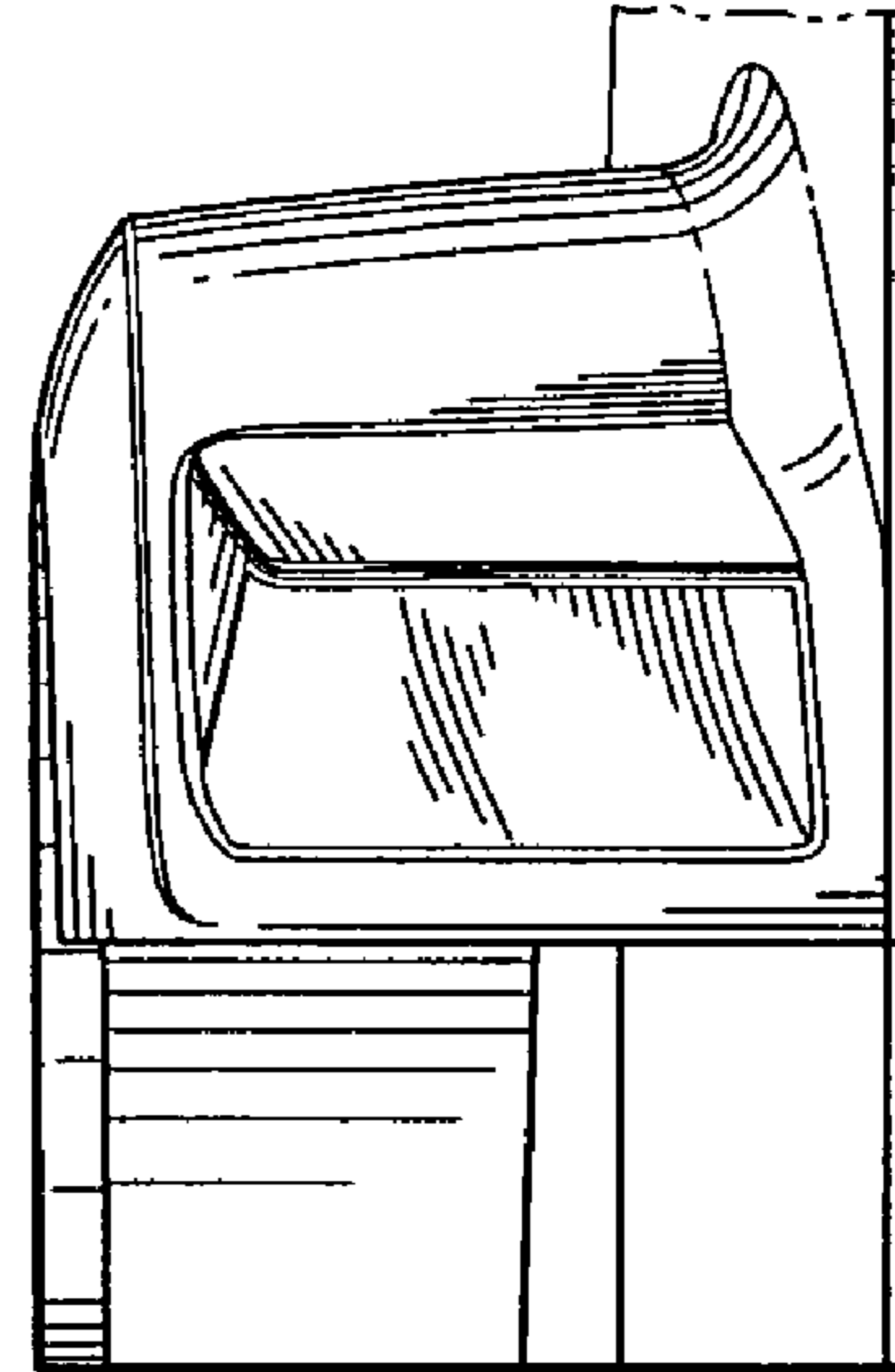


*Fig. 6.*

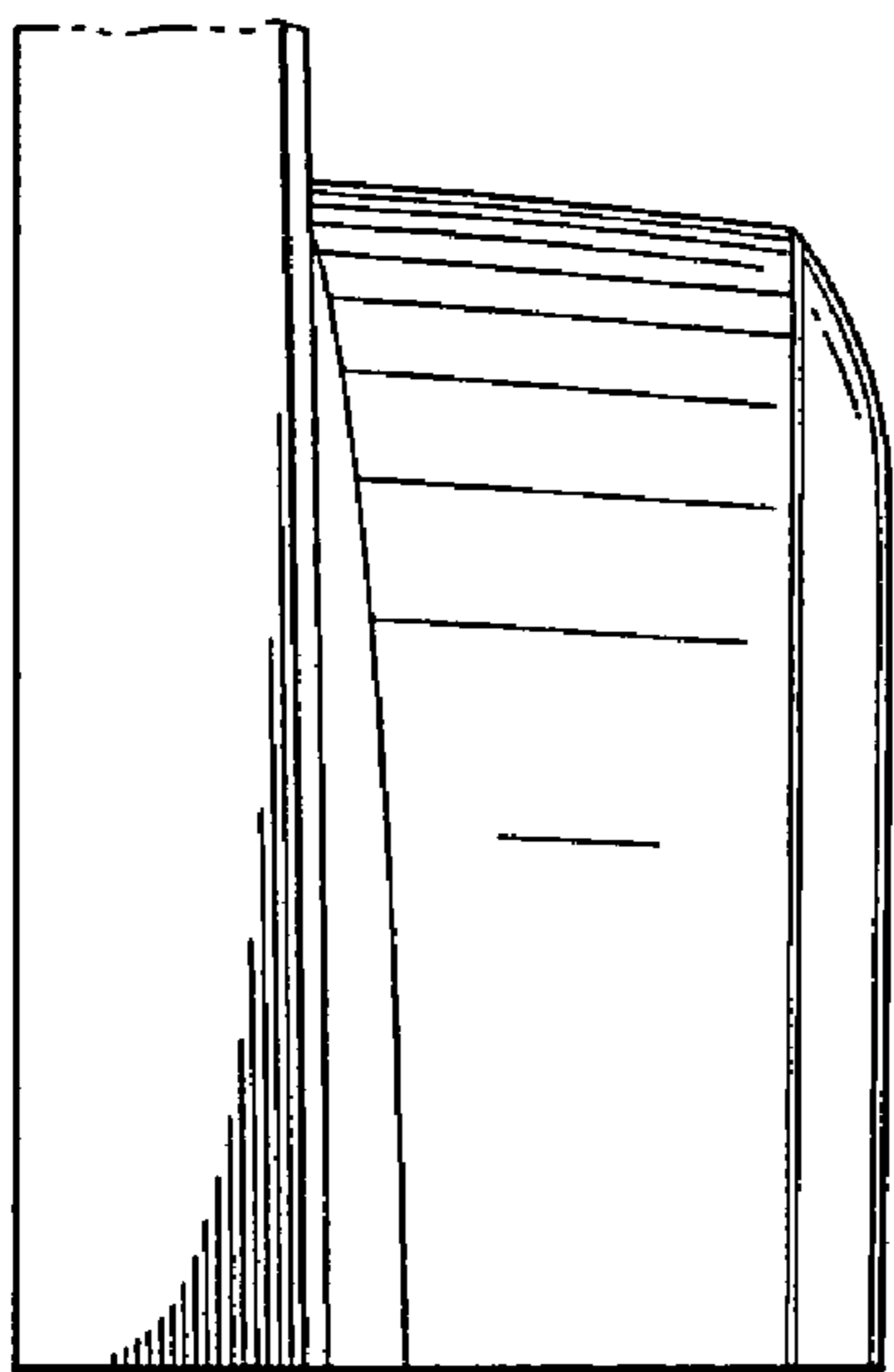


*Fig. 7.*

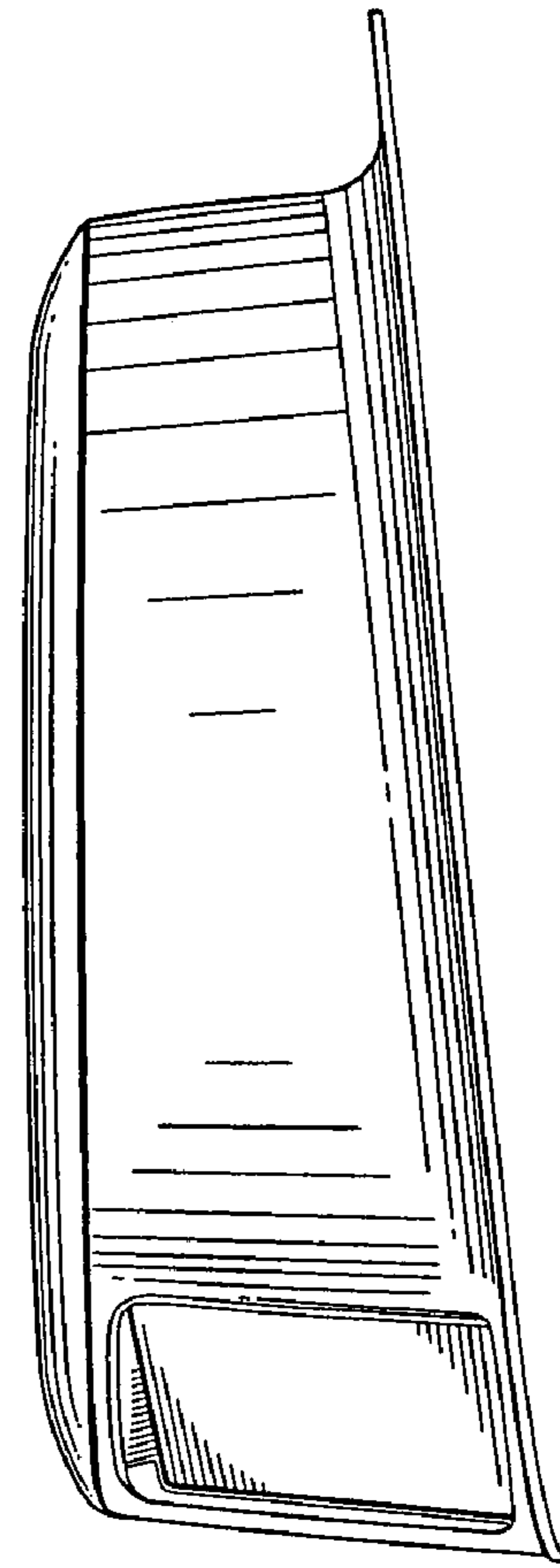
*Fig. 8.*



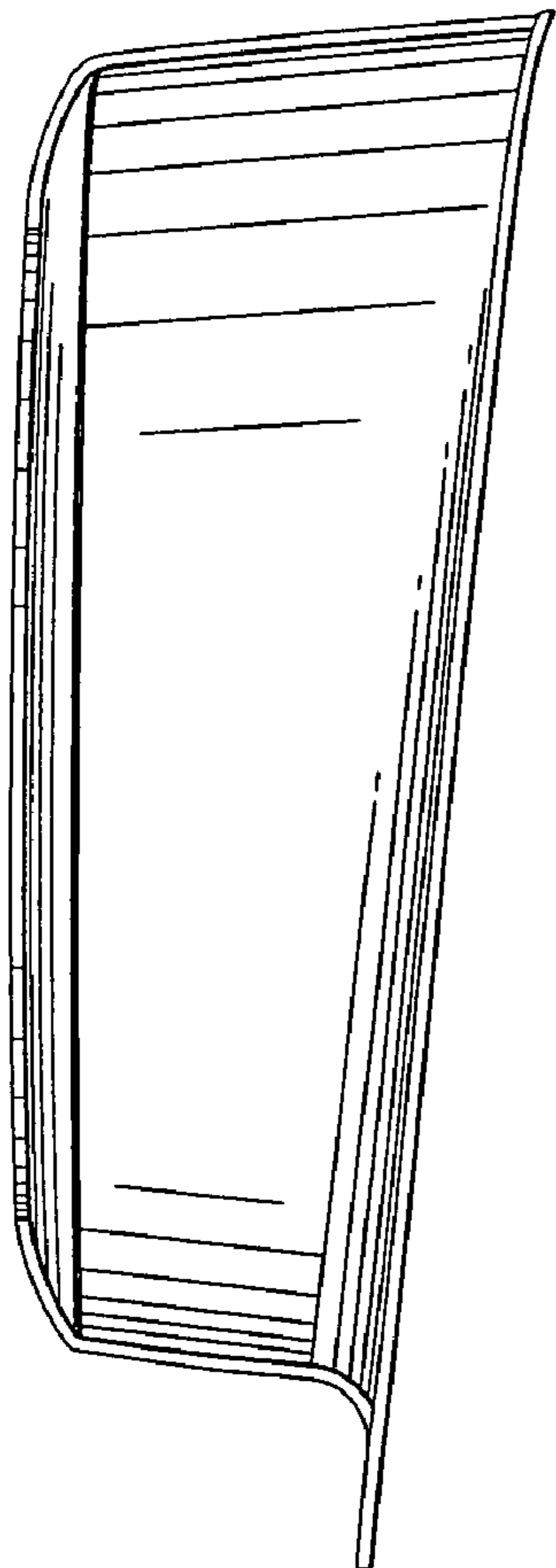
*Fig. 9.*



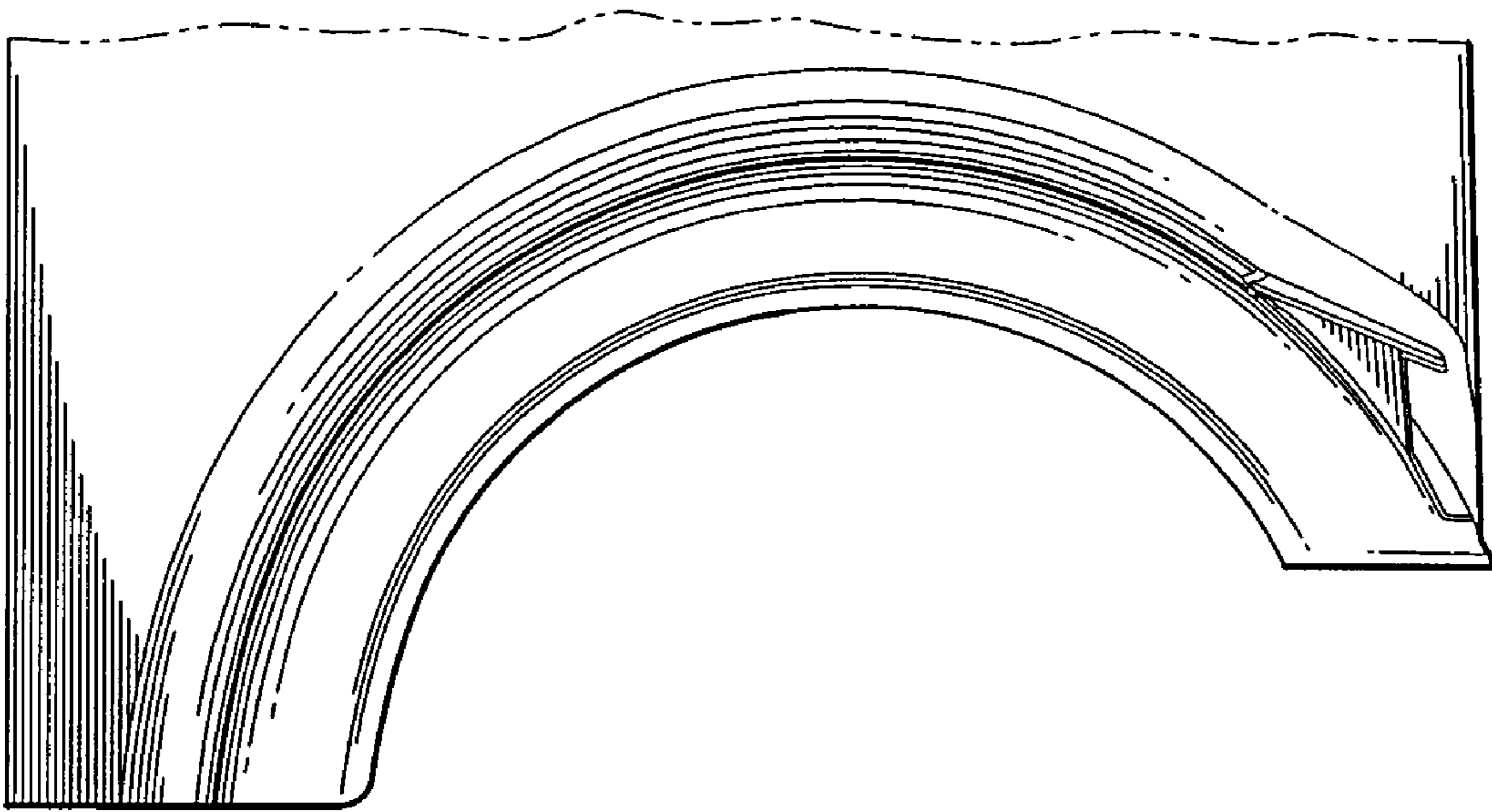




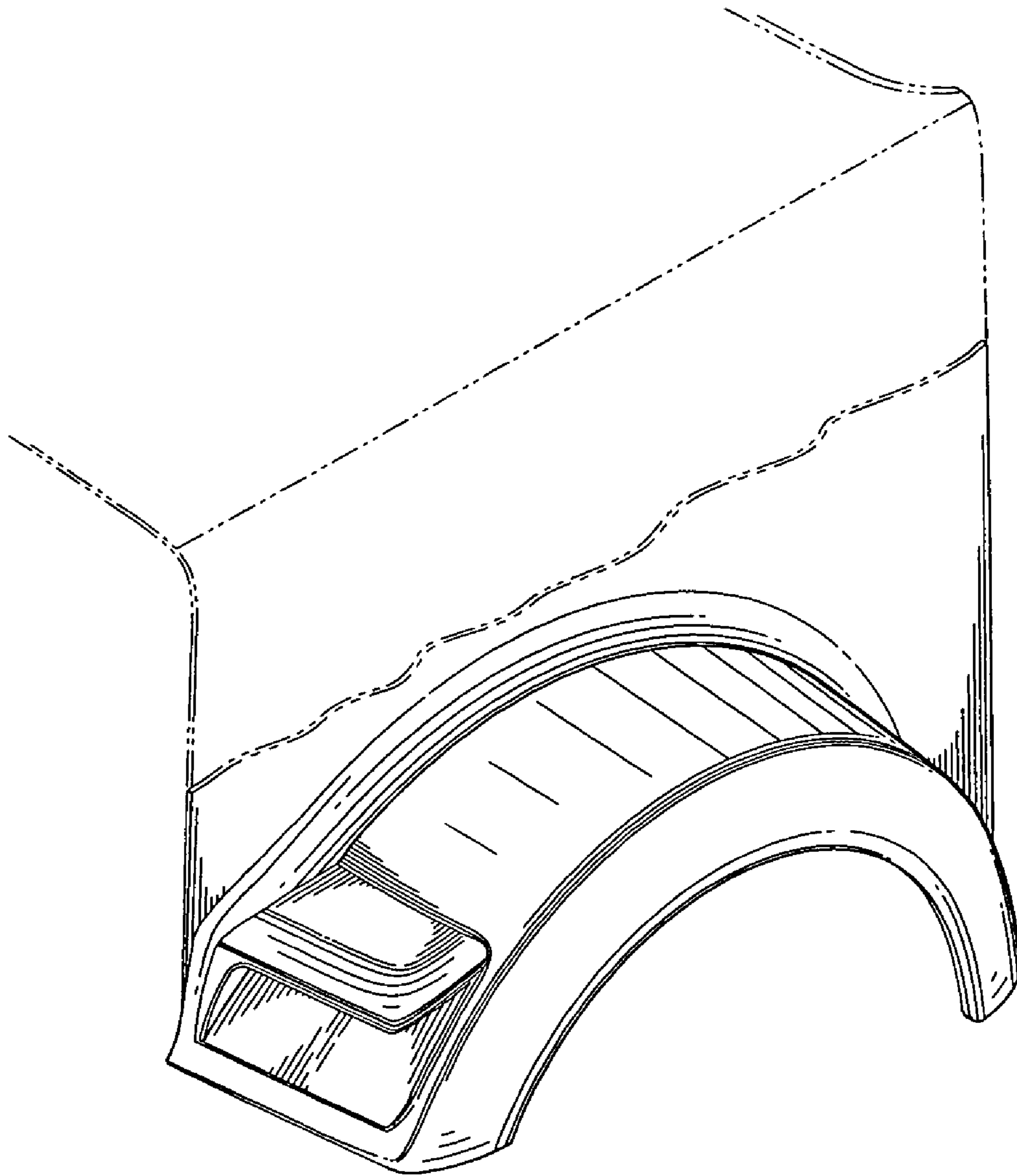
*Fig. 10.*



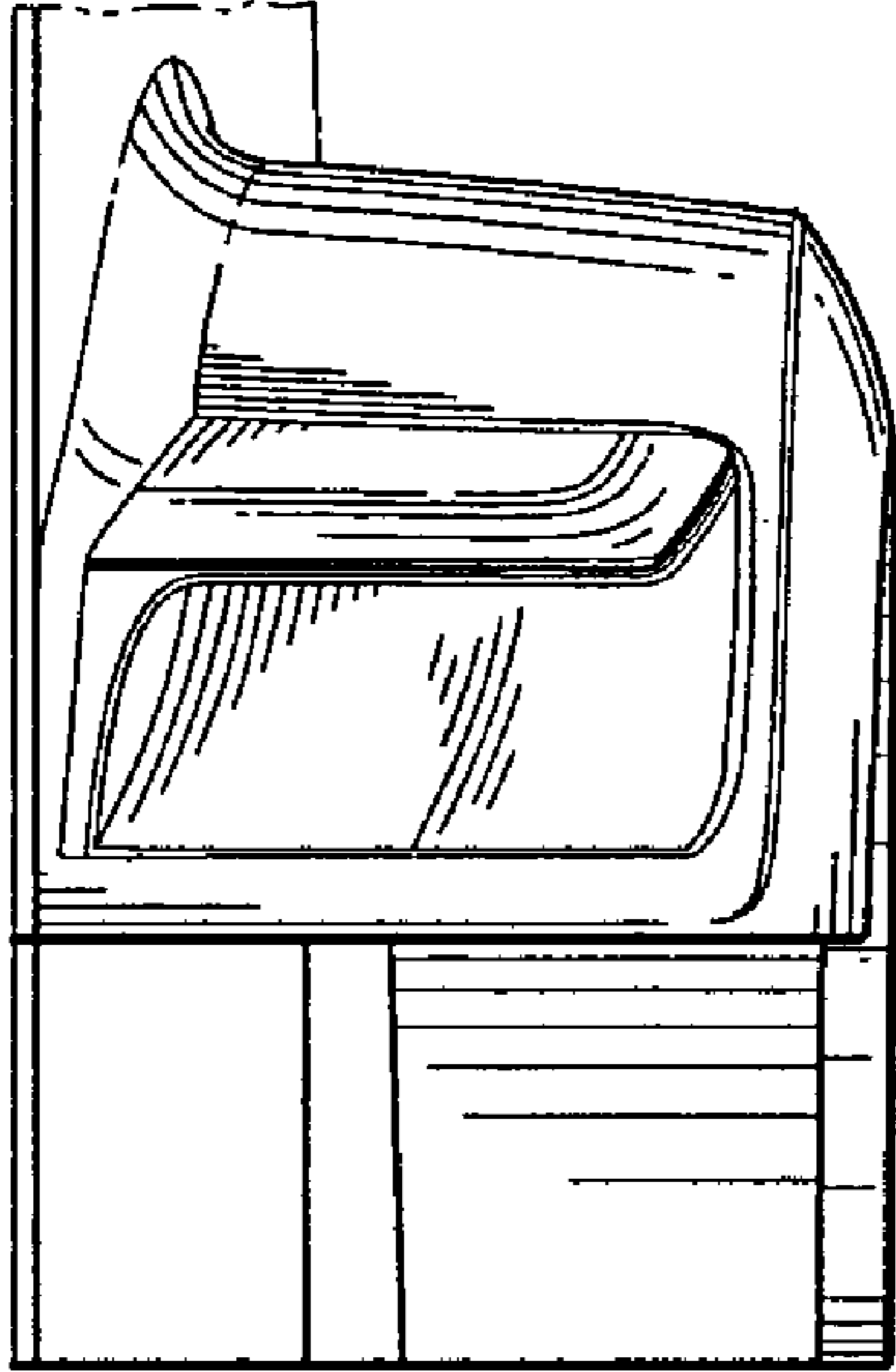
*Fig. 11.*



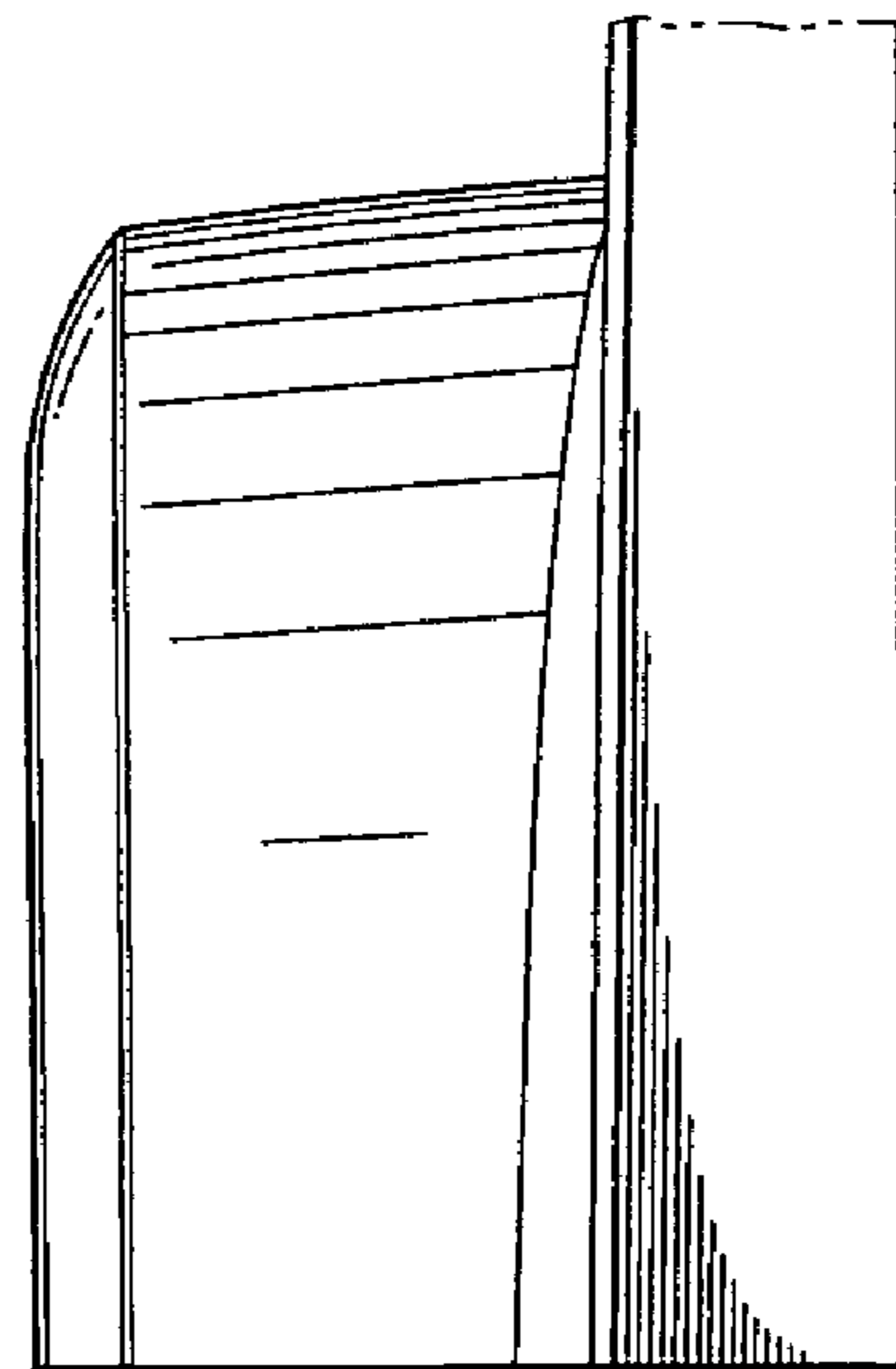
*Fig.12.*



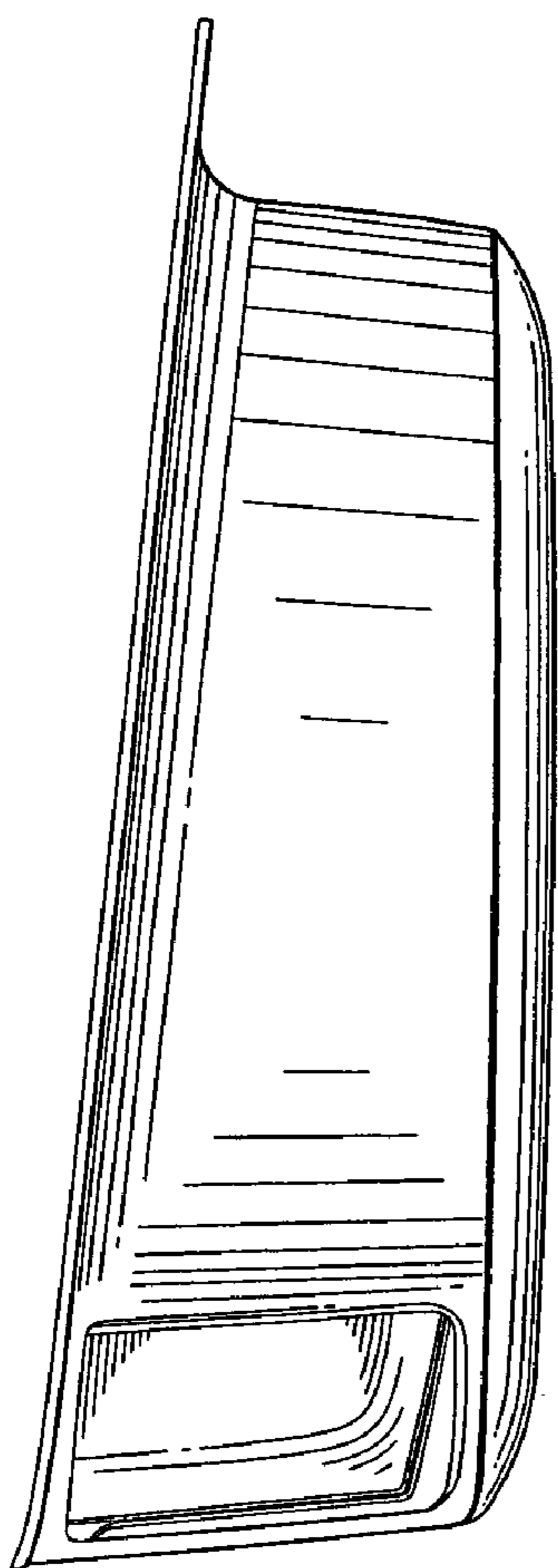
*Fig. 13.*



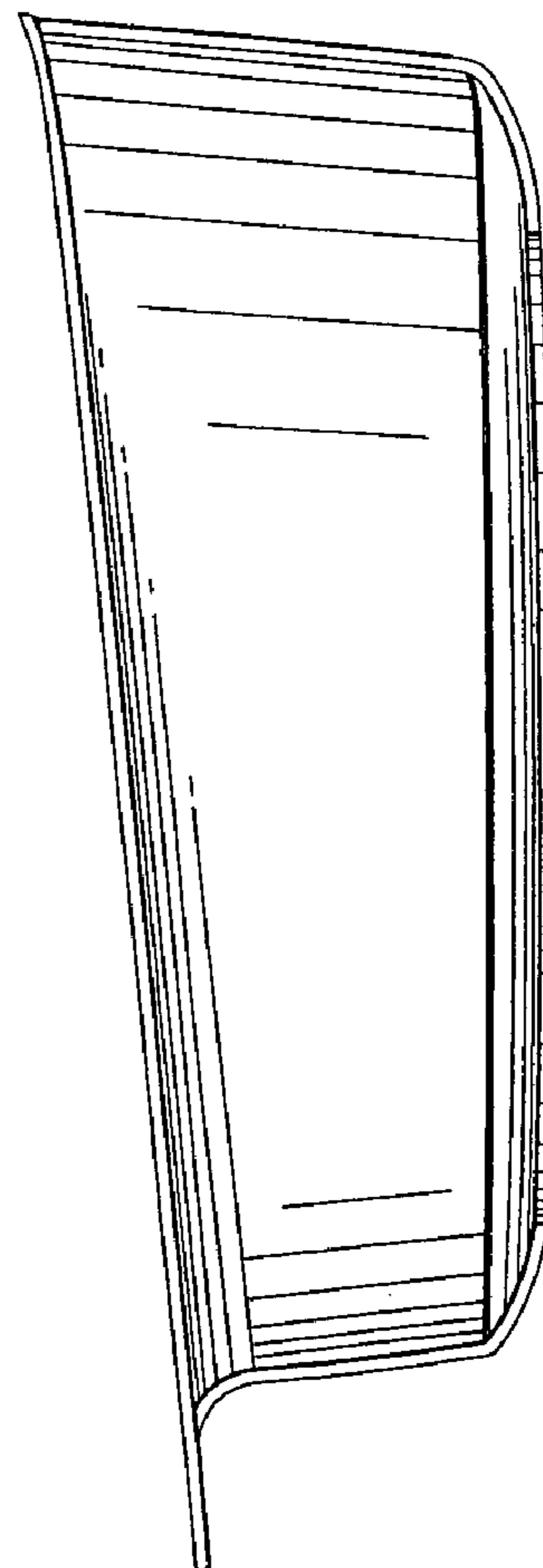
*Fig. 14.*



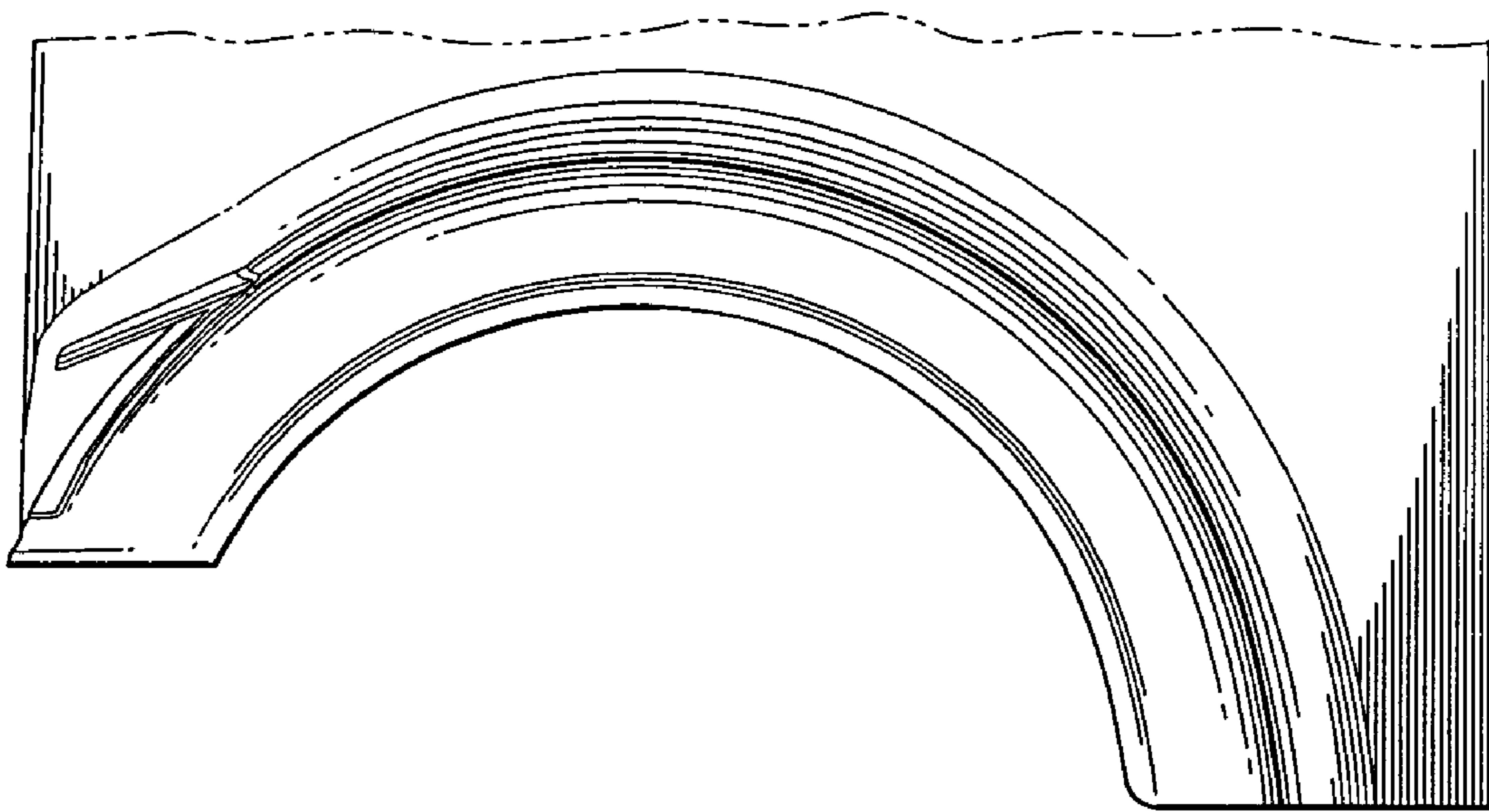
*Fig. 15.*



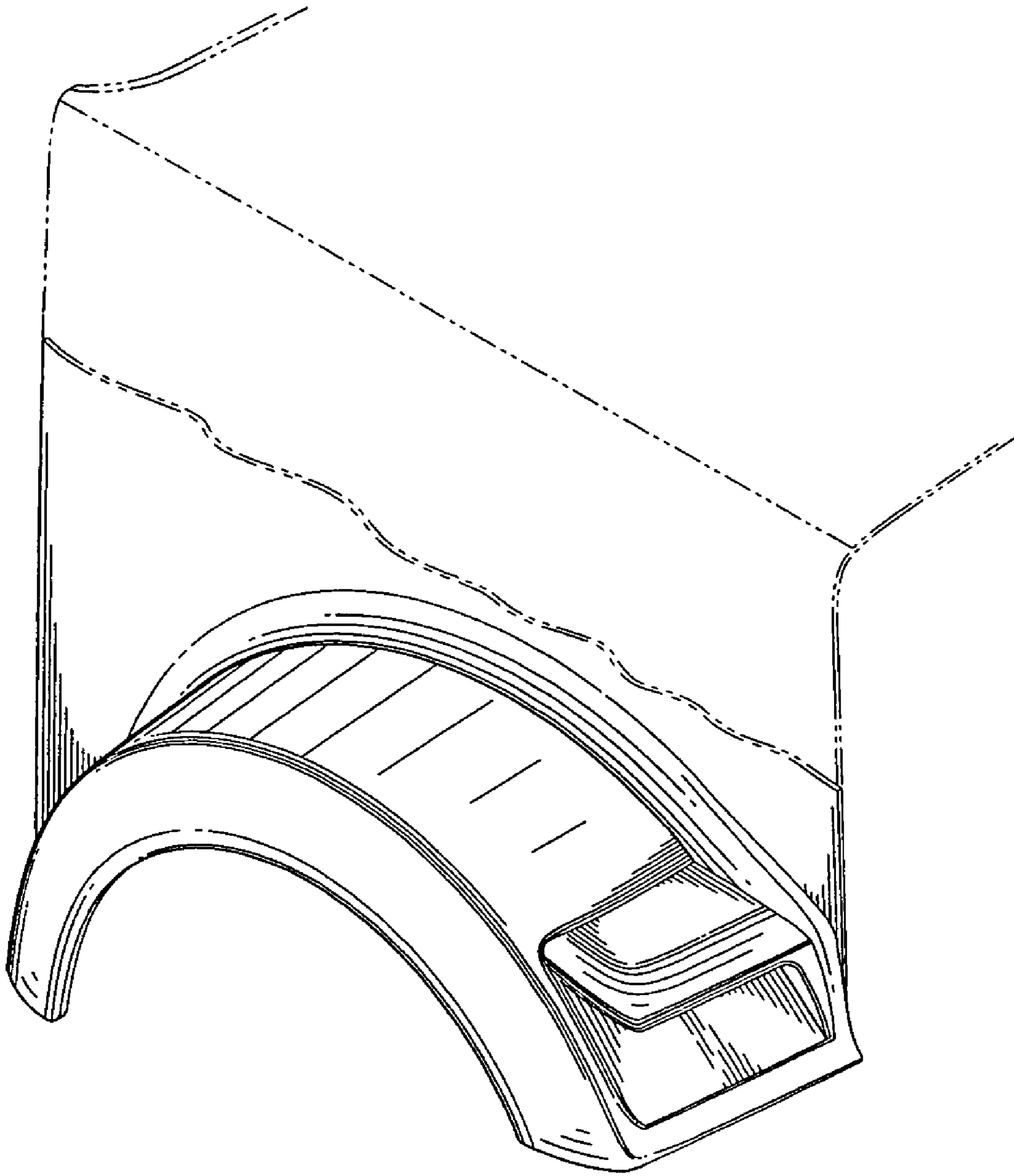
*Fig.16.*



*Fig.17.*

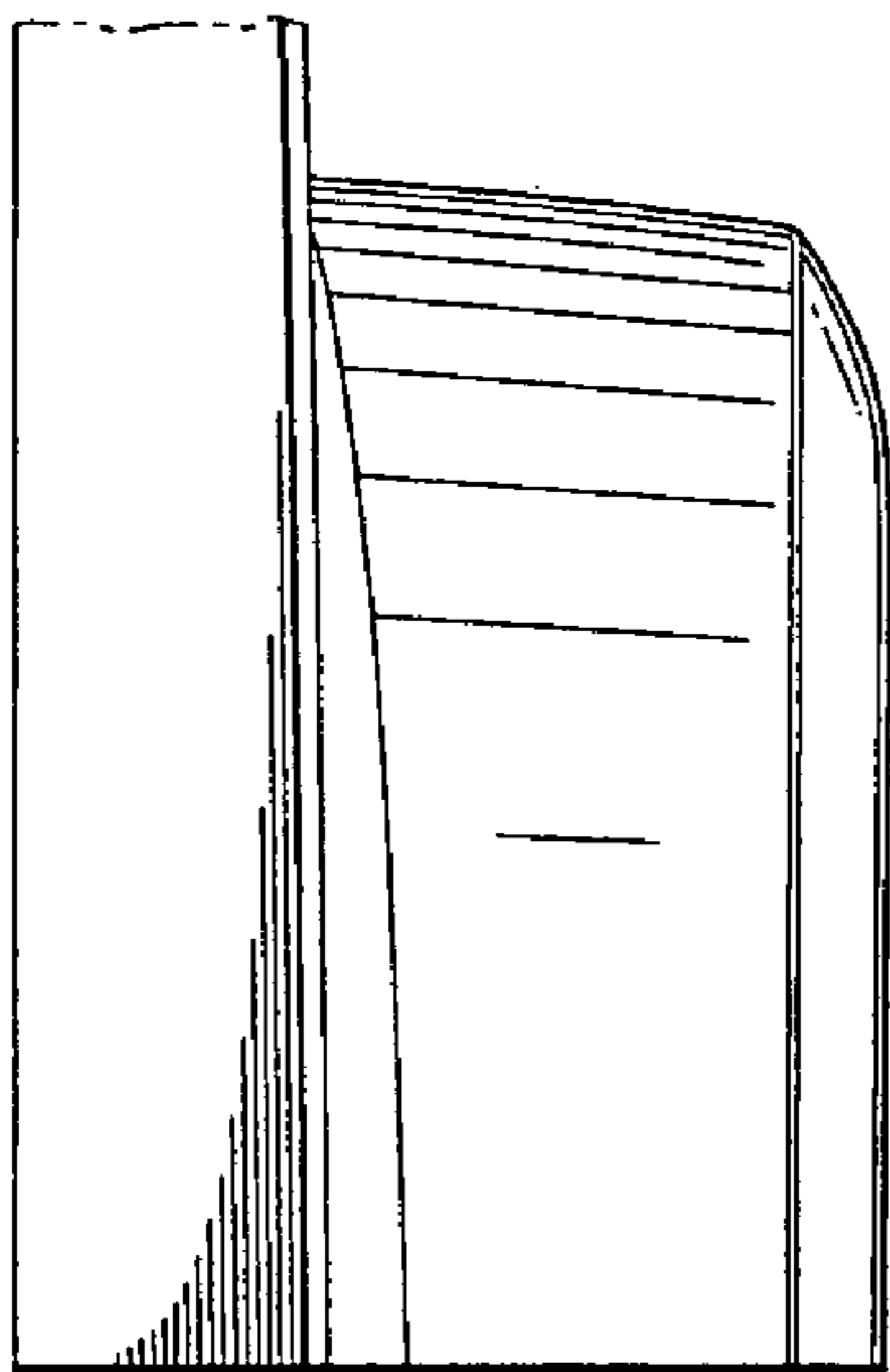
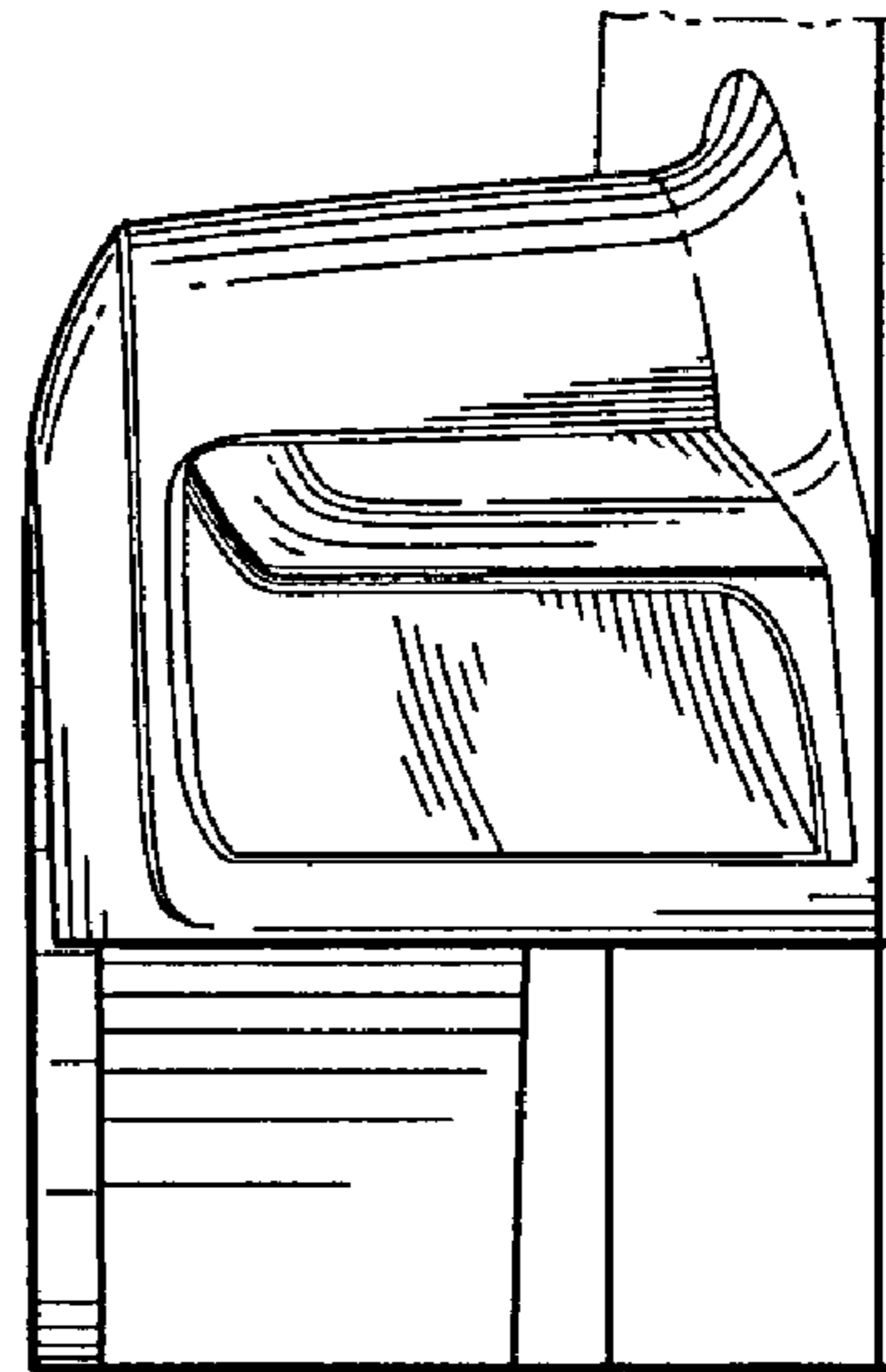


*Fig. 18.*



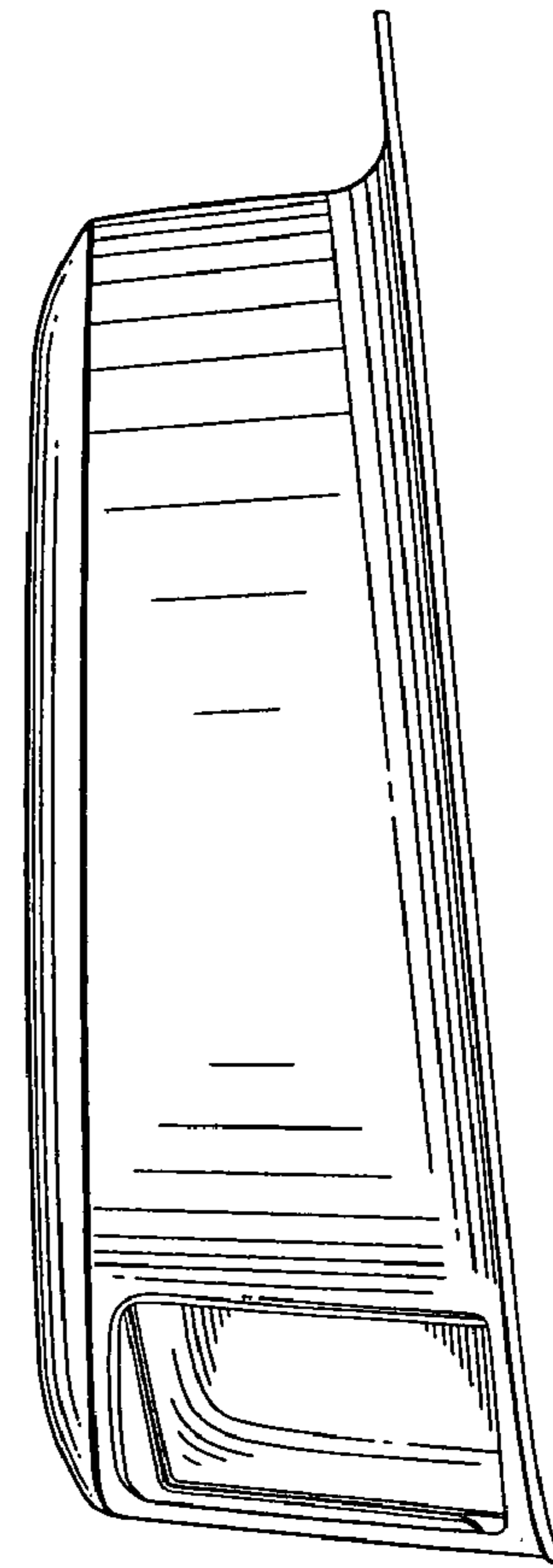
*Fig. 19.*

*Fig. 20.*

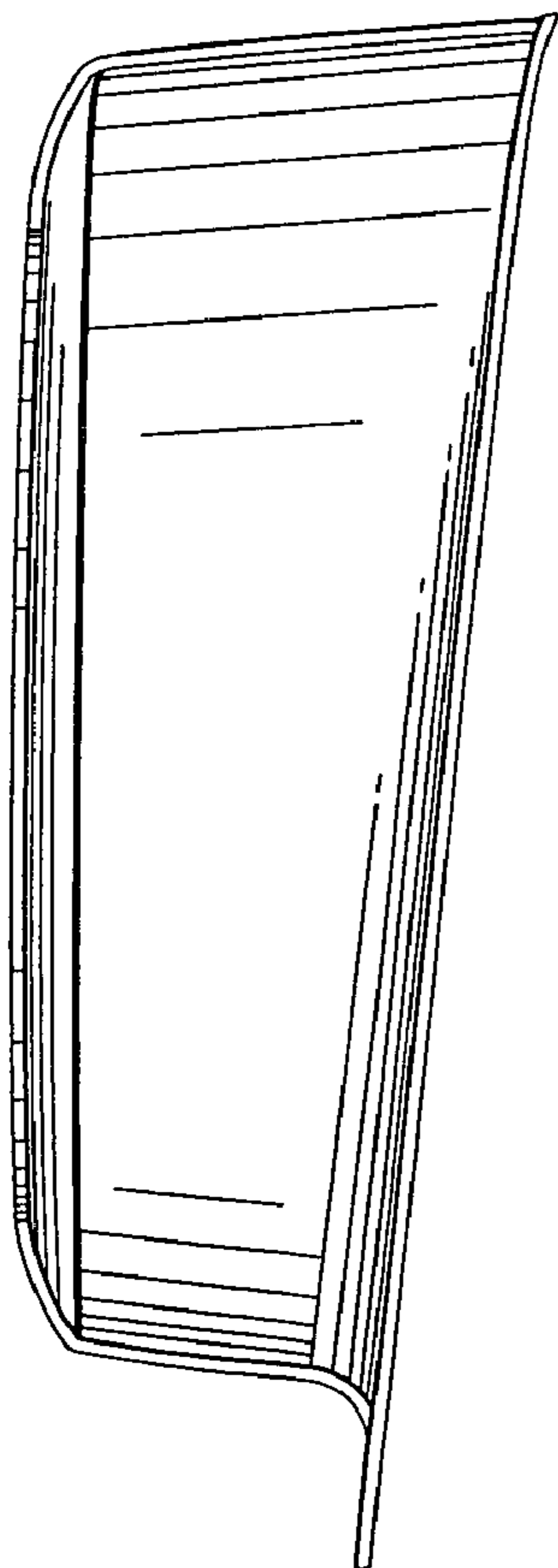


*Fig. 21.*

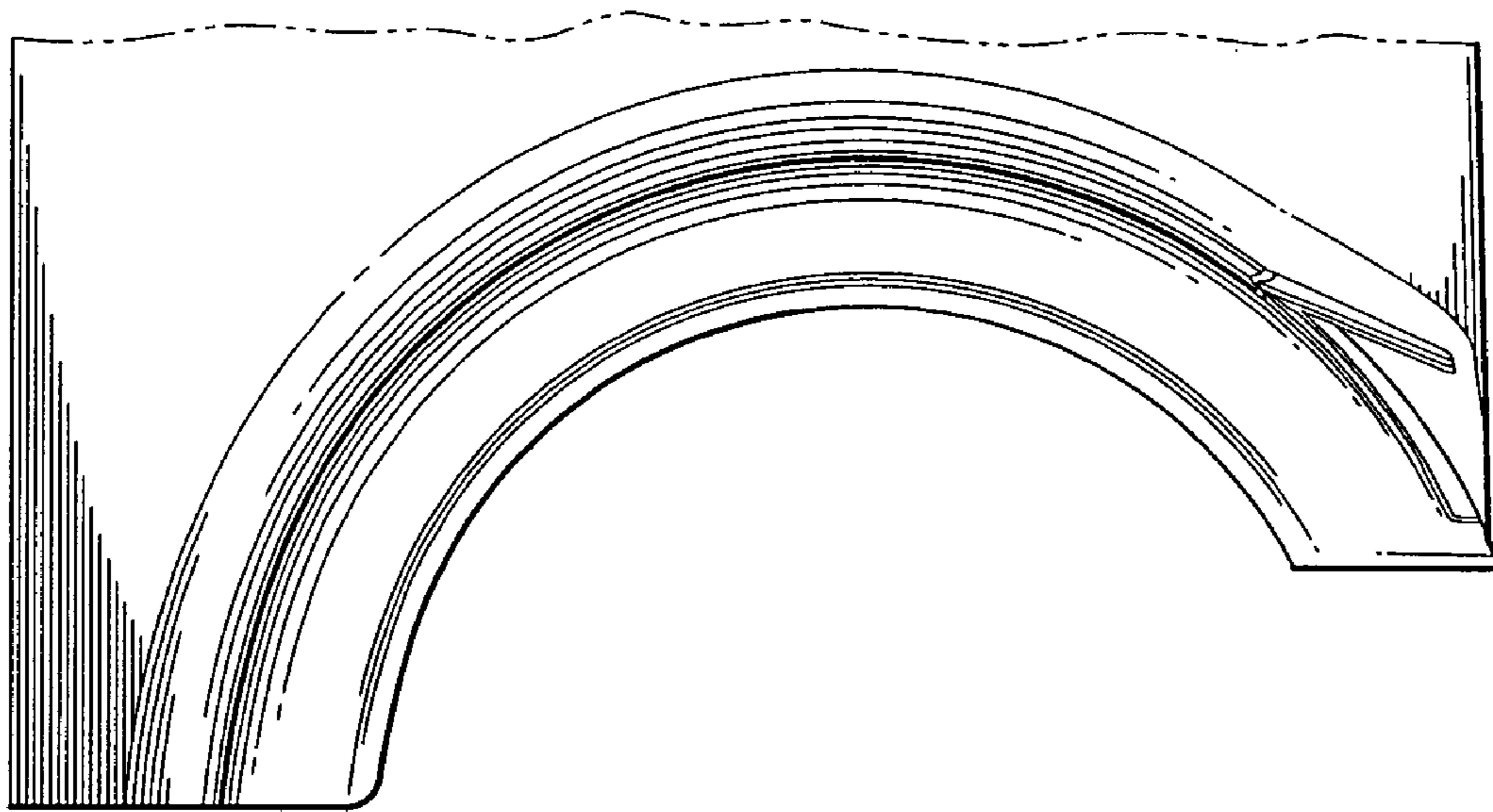




*Fig. 22.*



*Fig. 23.*



*Fig. 24.*